



**OPPA European Social Fund
Prague & EU: We invest in your future.**

FOCAL LENGTH MEASUREMENT AND THE STUDY OF LENS ABERRATIONS

OBJECT

1. To measure the focal length of a converging lens from the positions of the image and the object and from the lateral magnification.
2. To measure the focal length of a diverging lens.
3. To measure the spherical aberration.
4. To measure the chromatic aberration.

THEORY

The relationship linking the position of an object, its image and the focal length of a thin lens is given by the so-called the *thin lens equation*

$$\frac{1}{a} + \frac{1}{a'} = \frac{1}{f} \quad (1)$$

where a is the distance of the object from the center of the lens, a' is the distance of the image from the center of the lens and f is the focal length. The focal length depends on the curvature of the lens surfaces and the material from which it is made.

The *focal length* is taken positive for converging lenses and negative for diverging lenses.

The *object distance* is taken positive if the object is on the side of the lens from which the light is coming.

The *image distance* is taken positive if the image is on the opposite side of the lens from where the light is coming. If it is on the same side the image distance is negative.

The *image distance* is positive for a real image and negative for a virtual image.

Object and image heights are positive for points above the axis and negative for points below the axis.

The *lateral magnification* β of a lens is defined as the ratio of the image height y' to the object height y

$$|\beta| = \left| \frac{y'}{y} \right| = \frac{a'}{a} \quad (2)$$

For an upright image this magnification is positive and for an inverted image the magnification is negative.

The rays which pass through a lens close to its center are focused at different points than the rays passing far from the center. This is called *spherical aberration*. For a point object the image will not be a point but a very small circular surface.

If the light is not monochromatic we can observe *chromatic aberration*. This aberration is due to the variation of the index of refraction with wavelength. For example - blue light is bent by glass more than red light. Thus if white light is incident on a lens the different colors are focused at different points and we observe a non-sharp colored image.

PROCEDURE

- When you have measured the object distance a and the image distance a' you can use Eq. (1) to state the focal length f :

$$f = \frac{aa'}{a+a'} \quad (3)$$

The course of the rays and the experimental arrangement are shown in the following figure

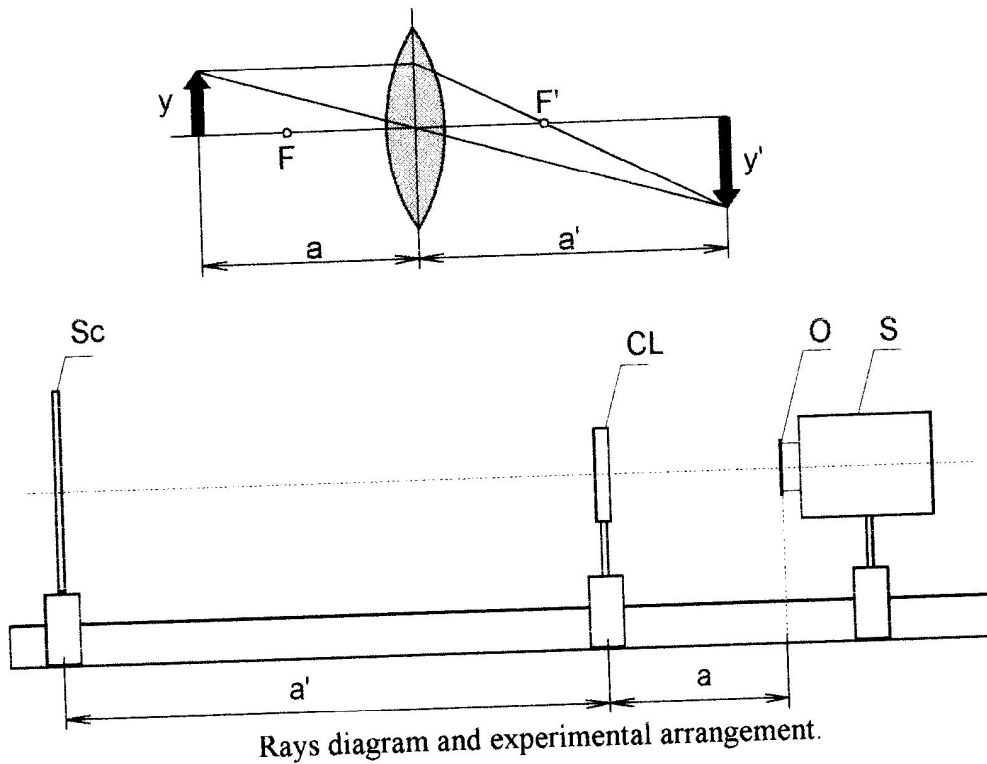

Place the object O (arrow) on an optical bench which has a millimeter scale. At the other end you place the screen Sc. Place the converging lens CL near to the object O, and move with it till you observe a sharp image on the screen. Now read on the scale distances a and a' , and at the same time measure the heights of image y' and object y . The focal length is now calculated from Eq.(3).

You can also calculate the focal length in terms of lateral magnification. From Eq.(3) you have

$$f = a' \frac{1}{1 + \frac{a'}{a}}$$

and the focal length can now be calculated from the equation

$$f = a' \frac{1}{1 + |\beta|} \quad (4)$$

Compare the two results and compare them with the numerical magnitude written on the lens.

Repeat the measurement 5 times for different positions of the screen.

- A diverging lens creates at any time a virtual image of a real object. To measure its focal length we have to add the converging lens to the measured diverging lens to

create an optical system with positive dioptric power. The course of the rays for such a system is shown in the following figure.

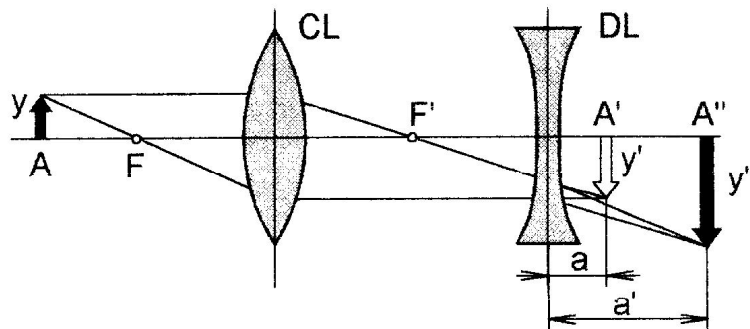

Measurement of the focal length of a diverging lens.

The beam of rays leaving point A of the object after passage through the converging lens CL converges at point A' of the object. Place the diverging lens DL – point A' must be located between this lens and its first focal point. The beam of rays does not converge at point A' but at point A'' . Point A'' is the image of object A created by the system of two lenses. Point A' represents the virtual object for the diverging lens. Thus we can write the lens equation in the form

$$\frac{1}{a'} - \frac{1}{a} = -\frac{1}{f'} \quad (5)$$

where f' , a' and a describe the absolute values of the focal point of the diverging lens, the image distance and the object distance, respectively.

From Eq.(5) we can state the focal length of the diverging lens:

$$f' = \frac{a a'}{a' - a} \quad (6)$$

The experimental arrangement is shown in the following figure.

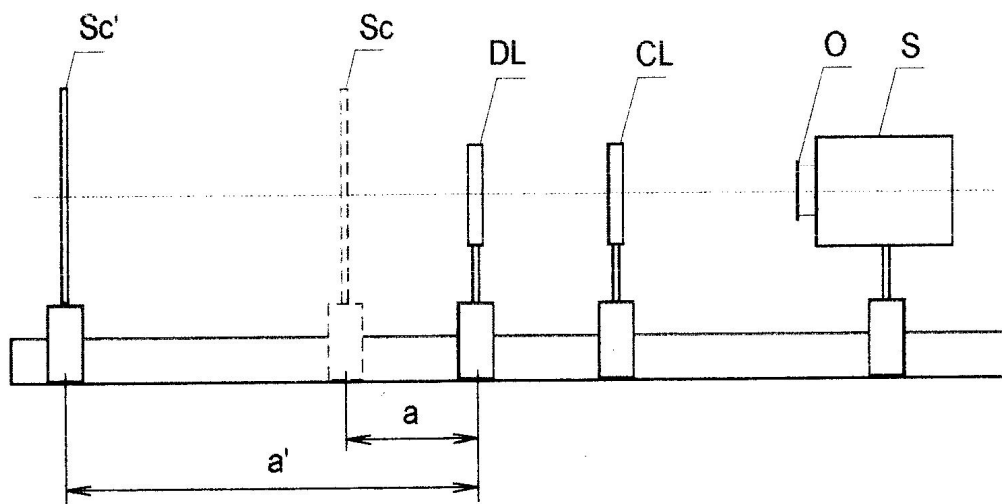

Experimental arrangement of the optical bench.

- 1) On the screen at position Sc (stroke) we create a sharp image of object O by means of the converging lens CL .
- 2) Then we place the diverging lens DL between the screen Sc and the converging lens CL . The image loses its sharpness.
- 3) We read the distance a of the diverging lens DL from the screen Sc .

- 4) We remove the screen from the diverging lens DL till a sharp image is again created. The new position of the screen is indicated as Sc' .
- 5) We read the new distance a' between DL and Sc' .
- 6) We determine the focal length of the diverging lens from Eq.(6).
- 7) We repeat the measurement 5 times for different initial positions of the screen.
- 8) We compare the calculated focal length f' with the value written on the lens.

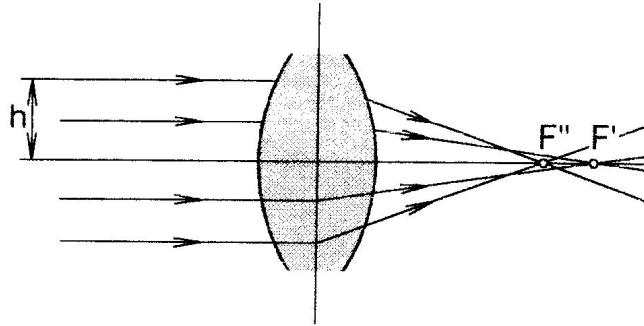

Spherical aberration.

3. Let the beam of rays parallel with the optical axis be incident on the converging lens CL. The rays are refracted to the focal point F' . Let the rays passing through the lens at distance h from the optical axis be refracted to point F'' . The spherical aberration Δa_∞ is equal to the distance $\overline{F'F''}$. Now for each diaphragm D we determine the distance (a'_0, a'_1, a'_2, \dots) between the converging lens CL and the screen Sc for which the image has maximum sharpness. The course of the spherical aberration is calculated from the expressions

$$\Delta a'_1 = a'_1 - a'_0, \quad \Delta a'_2 = a'_2 - a'_0, \dots$$

where a'_0 is the distance for the diaphragm with the smallest hole.

The values $\Delta a'_k$ describe the spherical aberration for the case when the distance of the object from the lens equals just $|a|$. We must now transform them for the case of an infinitely distant object:

$$\Delta a'_{\infty, k} = \Delta a'_k \frac{(|a| - f)^2}{a^2},$$

where $\Delta a'_{\infty, k}$ represents the spherical aberration for an infinitely distant object.

The experimental arrangement for this measurement is shown in the following figure.

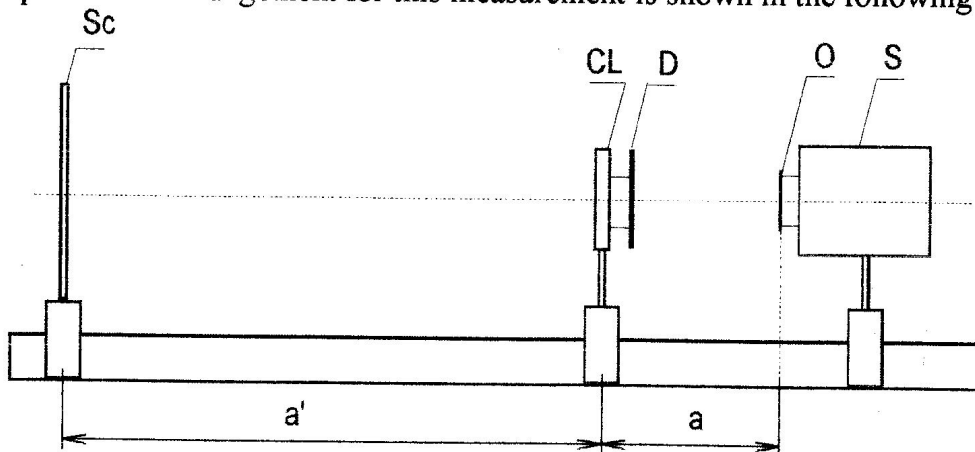

Experimental arrangement.

4. To examine the chromatic aberration we read the positions of the micrometer eyepiece E at the moment of the sharpest image for different diaphragms and different colours of light. We place the converging lens with the colour filter CF in front of the micrometer eyepiece E. We read the positions for the sharp red, blue and violet images. The position of the lens is constant for all filters. The experimental arrangement is shown in the following figure.

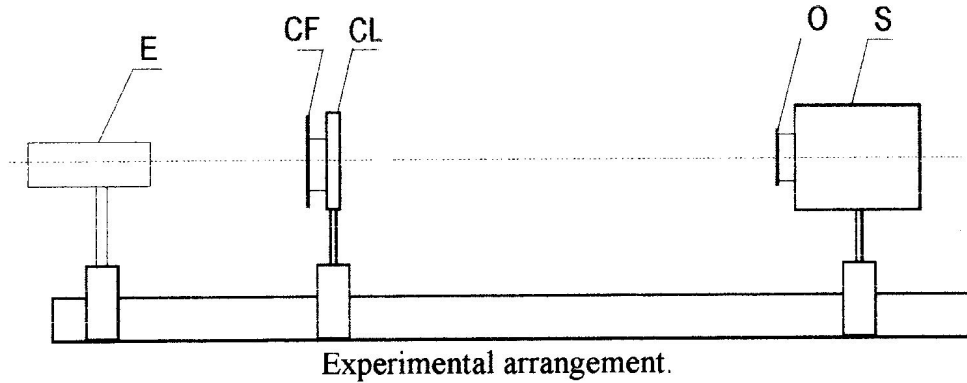

SEMESTER WORK INSTRUCTIONS

Create a program, which models beam trajectories and image creation as a function of distances, focal lengths and lens types. Simulate chromatic aberration by the dependence of refraction index of the lens material on the wavelength.



**OPPA European Social Fund
Prague & EU: We invest in your future.**
