



Neural Networks.

Petr Pošík
`petr.posik@fel.cvut.cz`

Czech Technical University in Prague
Faculty of Electrical Engineering
Dept. of Cybernetics



Introduction and Rehearsal



Notation

In *supervised learning*, we work with

- an observation described by a vector $\mathbf{x} = (x_1, \dots, x_D)$,
- the corresponding true value of the dependent variable y , and
- the prediction of a model $\hat{y} = f_w(\mathbf{x})$, where the model parameters are in vector w .
- Very often, we use *homogeneous coordinates* and matrix notation, and represent the whole training data set as $T = (\mathbf{X}, \mathbf{y})$, where

$$\mathbf{X} = \begin{pmatrix} 1 & \mathbf{x}^{(1)} \\ \vdots & \vdots \\ 1 & \mathbf{x}^{(|T|)} \end{pmatrix}, \quad \text{and} \quad \mathbf{y} = \begin{pmatrix} y^{(1)} \\ \vdots \\ y^{(|T|)} \end{pmatrix}.$$

Learning then amounts to finding such model parameters w^* which minimize certain loss (or energy) function:

$$w^* = \arg \min_w J(w, T)$$

Intro

- Notation
- Multiple regression
- Logistic regression
- Quiz
- Gradient descent
- Ex: Grad. for MR
- Ex: Grad. for LR
- Relations to NN

Multilayer FFN

Gradient Descent

Regularization

Other NNs

Summary



Multiple linear regression

Multiple linear regression model:

$$\hat{y} = f_w(\mathbf{x}) = w_1x_1 + w_2x_2 + \dots + w_Dx_D = \mathbf{x}\mathbf{w}^T$$

The minimum of

$$J_{MSE}(\mathbf{w}) = \frac{1}{|T|} \sum_{i=1}^{|T|} \left(y^{(i)} - \hat{y}^{(i)} \right)^2,$$

is given by

$$\mathbf{w}^* = (\mathbf{X}^T \mathbf{X})^{-1} \mathbf{X}^T \mathbf{y},$$

or found by numerical optimization.

Intro

- Notation
- **Multiple regression**
- Logistic regression
- Quiz
- Gradient descent
- Ex: Grad. for MR
- Ex: Grad. for LR
- Relations to NN

Multilayer FFN

Gradient Descent

Regularization

Other NNs

Summary



Multiple linear regression

Multiple linear regression model:

$$\hat{y} = f_w(\mathbf{x}) = w_1x_1 + w_2x_2 + \dots + w_Dx_D = \mathbf{x}\mathbf{w}^T$$

The minimum of

$$J_{MSE}(\mathbf{w}) = \frac{1}{|T|} \sum_{i=1}^{|T|} \left(y^{(i)} - \hat{y}^{(i)} \right)^2,$$

is given by

$$\mathbf{w}^* = (\mathbf{X}^T \mathbf{X})^{-1} \mathbf{X}^T \mathbf{y},$$

or found by numerical optimization.

Multiple regression as a **linear neuron**:

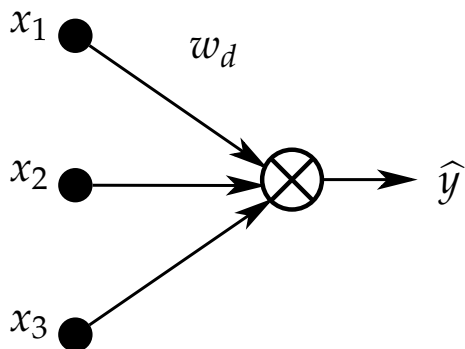

Intro

- Notation
- **Multiple regression**
- Logistic regression
- Quiz
- Gradient descent
- Ex: Grad. for MR
- Ex: Grad. for LR
- Relations to NN

Multilayer FFN

Gradient Descent

Regularization

Other NNs

Summary



Logistic regression

Logistic regression model:

$$\hat{y} = f(w, x) = g(xw^T),$$

where

$$g(z) = \frac{1}{1 + e^{-z}}$$

is the **sigmoid** (a.k.a **logistic**) function.

- No explicit equation for the optimal weights.
- The only option is to find the optimum numerically, usually by some form of gradient descent.

Intro

- Notation
- Multiple regression
- **Logistic regression**
- Quiz
- Gradient descent
- Ex: Grad. for MR
- Ex: Grad. for LR
- Relations to NN

Multilayer FFN

Gradient Descent

Regularization

Other NNs

Summary



Logistic regression

Logistic regression model:

$$\hat{y} = f(w, x) = g(xw^T),$$

where

$$g(z) = \frac{1}{1 + e^{-z}}$$

is the **sigmoid** (a.k.a **logistic**) function.

- No explicit equation for the optimal weights.
- The only option is to find the optimum numerically, usually by some form of gradient descent.

Logistic regression as a **non-linear neuron**:

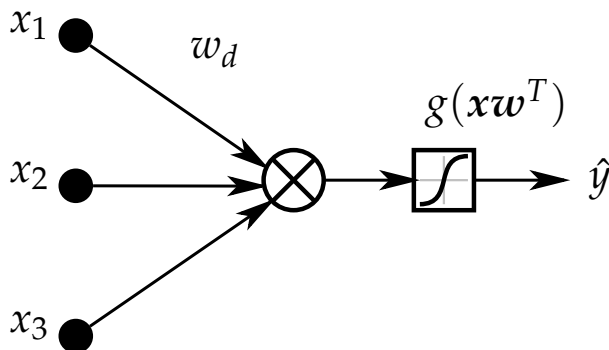

Intro

- Notation
- Multiple regression
- **Logistic regression**
- Quiz
- Gradient descent
- Ex: Grad. for MR
- Ex: Grad. for LR
- Relations to NN

Multilayer FFN

Gradient Descent

Regularization

Other NNs

Summary



Quiz

Logistic regression uses sigmoid function to transform the result of the linear combination of inputs:

$$g(z) = \frac{1}{1 + e^{-z}}$$

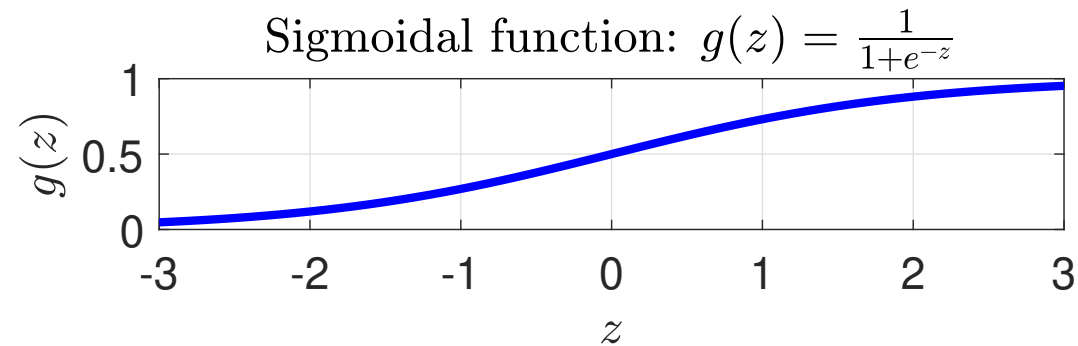

Intro

- Notation
- Multiple regression
- Logistic regression
- **Quiz**
- Gradient descent
- Ex: Grad. for MR
- Ex: Grad. for LR
- Relations to NN

Multilayer FFN

Gradient Descent

Regularization

Other NNs

Summary

What is the value of the derivative of $g(z)$ at $z = 0$?

A $g'(0) = -\frac{1}{2}$

B $g'(0) = 0$

C $g'(0) = \frac{1}{4}$

D $g'(0) = \frac{1}{2}$



Gradient descent algorithm

Intro

- Notation
- Multiple regression
- Logistic regression
- Quiz
- **Gradient descent**
- Ex: Grad. for MR
- Ex: Grad. for LR
- Relations to NN

Multilayer FFN

Gradient Descent

Regularization

Other NNs

Summary

- Given a function $J(\boldsymbol{w})$ that should be minimized,
- start with a guess of \boldsymbol{w} , and change it so that $J(\boldsymbol{w})$ decreases, i.e.
- update our current guess of \boldsymbol{w} by taking a step in the direction opposite to the gradient:

$$\boldsymbol{w} \leftarrow \boldsymbol{w} - \eta \nabla J(\boldsymbol{w}), \text{ i.e.}$$

$$w_d \leftarrow w_d - \eta \frac{\partial}{\partial w_d} J(\boldsymbol{w}),$$

where all w_d s are updated simultaneously and η is a **learning rate** (step size).

- For cost functions given as the sum across the training examples

$$J(\boldsymbol{w}) = \sum_{i=1}^{|T|} E(\boldsymbol{w}, \boldsymbol{x}^{(i)}, y^{(i)}),$$

we can concentrate on a single training example because

$$\frac{\partial}{\partial w_d} J(\boldsymbol{w}) = \sum_{i=1}^{|T|} \frac{\partial}{\partial w_d} E(\boldsymbol{w}, \boldsymbol{x}^{(i)}, y^{(i)}),$$

and we can drop the indices over training data set:

$$E = E(\boldsymbol{w}, \boldsymbol{x}, y).$$



Example: Gradient for multiple regression and squared loss

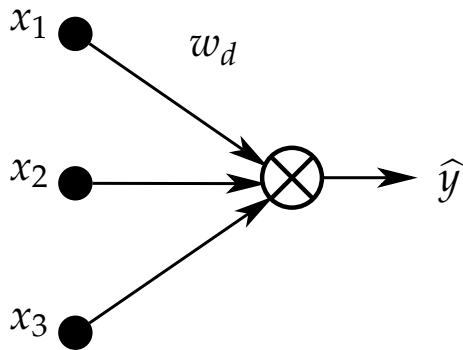

Assuming the squared error loss

$$E(\boldsymbol{w}, \boldsymbol{x}, y) = \frac{1}{2} (y - \hat{y})^2 = \frac{1}{2} (y - \boldsymbol{x}\boldsymbol{w}^T)^2,$$

we can compute the derivatives using the chain rule as

$$\frac{\partial E}{\partial w_d} = \frac{\partial E}{\partial \hat{y}} \frac{\partial \hat{y}}{\partial w_d}, \text{ where}$$

$$\frac{\partial E}{\partial \hat{y}} = \frac{\partial}{\partial \hat{y}} \frac{1}{2} (y - \hat{y})^2 = -(y - \hat{y}), \text{ and}$$

$$\frac{\partial \hat{y}}{\partial w_d} = \frac{\partial}{\partial w_d} \boldsymbol{x}\boldsymbol{w}^T = x_d,$$

and thus

$$\frac{\partial E}{\partial w_d} = \frac{\partial E}{\partial \hat{y}} \frac{\partial \hat{y}}{\partial w_d} = -(y - \hat{y})x_d.$$

Intro

- Notation
- Multiple regression
- Logistic regression
- Quiz
- Gradient descent
- Ex: Grad. for MR
- Ex: Grad. for LR
- Relations to NN

Multilayer FFN

Gradient Descent

Regularization

Other NNs

Summary



Example: Gradient for logistic regression and crossentropy loss

Intro

- Notation
- Multiple regression
- Logistic regression
- Quiz
- Gradient descent
- Ex: Grad. for MR
- Ex: Grad. for LR
- Relations to NN

Multilayer FFN

Gradient Descent

Regularization

Other NNs

Summary

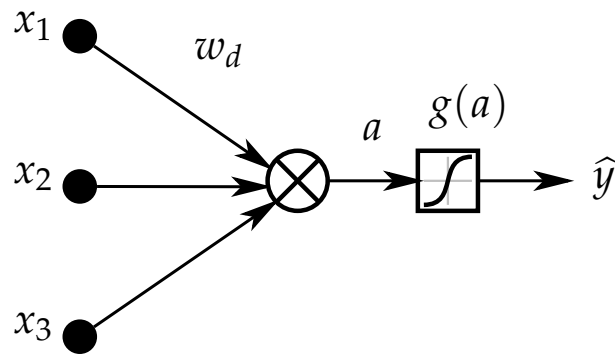

Nonlinear *activation* function:

$$g(a) = \frac{1}{1 + e^{-a}}$$

Note that

$$g'(a) = g(a) (1 - g(a)).$$



Example: Gradient for logistic regression and crossentropy loss

Intro

- Notation
- Multiple regression
- Logistic regression
- Quiz
- Gradient descent
- Ex: Grad. for MR
- Ex: Grad. for LR
- Relations to NN

Multilayer FFN

Gradient Descent

Regularization

Other NNs

Summary

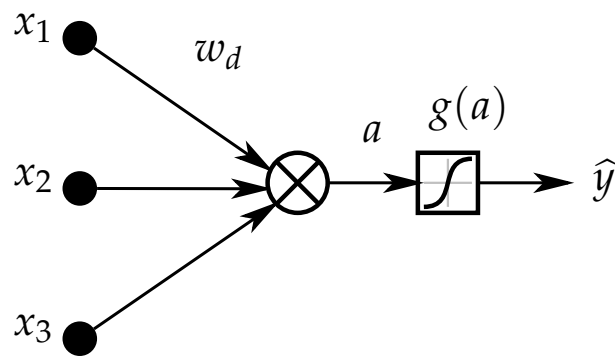

Nonlinear *activation* function:

$$g(a) = \frac{1}{1 + e^{-a}}$$

Note that

$$g'(a) = g(a) (1 - g(a)).$$

Assuming the crossentropy loss

$$E(\boldsymbol{w}, \boldsymbol{x}, y) = -y \log \hat{y} - (1 - y) \log(1 - \hat{y}), \quad \text{where } \hat{y} = g(a) = g(\boldsymbol{x}\boldsymbol{w}^T),$$

we can compute the derivatives using the chain rule as

$$\frac{\partial E}{\partial w_d} = \frac{\partial E}{\partial \hat{y}} \frac{\partial \hat{y}}{\partial a} \frac{\partial a}{\partial w_d}, \text{ where}$$

$$\frac{\partial E}{\partial \hat{y}} = -\frac{y}{\hat{y}} + \frac{1 - y}{1 - \hat{y}} = -\frac{y - \hat{y}}{\hat{y}(1 - \hat{y})},$$

$$\frac{\partial \hat{y}}{\partial a} = \hat{y}(1 - \hat{y}), \text{ and } \frac{\partial a}{\partial w_d} = \frac{\partial}{\partial w_d} \boldsymbol{x}\boldsymbol{w}^T = x_d,$$

and thus

$$\frac{\partial E}{\partial w_d} = \frac{\partial E}{\partial \hat{y}} \frac{\partial \hat{y}}{\partial a} \frac{\partial a}{\partial w_d} = -(y - \hat{y})x_d.$$



Relations to neural networks

- Above, we derived training algorithms (based on gradient descent) for linear regression model and linear classification model.
- Note the similarity with the *perceptron algorithm* (“just add certain part of a misclassified training example to the weight vector”).
- Units like those above are used as **building blocks** for more complex/flexible models!

Intro

- Notation
- Multiple regression
- Logistic regression
- Quiz
- Gradient descent
- Ex: Grad. for MR
- Ex: Grad. for LR
- Relations to NN

Multilayer FFN

Gradient Descent

Regularization

Other NNs

Summary



Relations to neural networks

Intro

- Notation
- Multiple regression
- Logistic regression
- Quiz
- Gradient descent
- Ex: Grad. for MR
- Ex: Grad. for LR
- Relations to NN

Multilayer FFN

Gradient Descent

Regularization

Other NNs

Summary

- Above, we derived training algorithms (based on gradient descent) for linear regression model and linear classification model.
- Note the similarity with the *perceptron algorithm* (“just add certain part of a misclassified training example to the weight vector”).
- Units like those above are used as **building blocks** for more complex/flexible models!

A more complex/flexible model:

$$\hat{y} = g^{OUT} \left(\sum_{k=1}^K w_k^{HID} g_k^{HID} \left(\sum_{d=1}^D w_{kd}^{IN} x_d \right) \right),$$

which is

- a nonlinear function of
 - a linear combination of
 - nonlinear functions of
 - linear combinations of inputs.



Multilayer Feedforward Networks



MLP

Multilayer perceptron (MLP)

- Multilayer feedforward network:
 - the „signal“ is propagated from inputs towards outputs; no feedback connections exist.
- It realizes mapping from $\mathcal{R}^D \rightarrow \mathcal{R}^C$, where D is the number of object features, and C is the number of output variables.
 - For binary classification and regression, a single output is sufficient.
 - For classification into multiple classes, 1-of-N encoding is usually used.
- **Universal approximation theorem:** A MLP with a single hidden layer with sufficient (but finite) number of neurons can approximate any continuous function arbitrarily well (under mild assumptions on the activation functions).

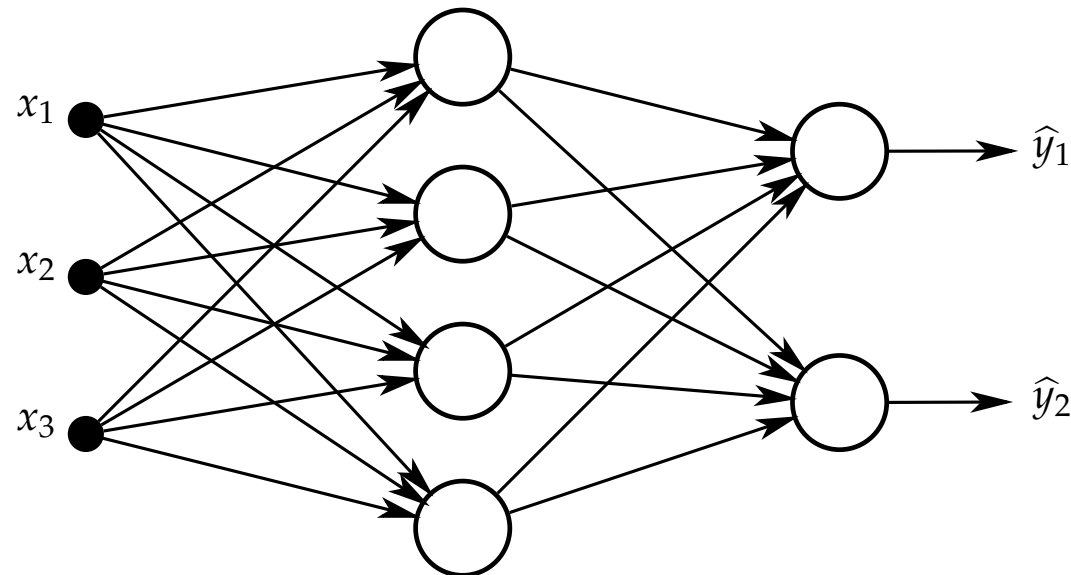

Intro

Multilayer FFN

- MLP
- MLP: A look inside
- Activation functions
- MLP: Learning
- Quiz
- BP
- BP algorithm
- BP: Example
- BP Efficiency
- Loss functions

Gradient Descent

Regularization

Other NNs

Summary



MLP: A look inside

Intro

Multilayer FFN

- MLP
- **MLP: A look inside**
- Activation functions
- MLP: Learning
- Quiz
- BP
- BP algorithm
- BP: Example
- BP Efficiency
- Loss functions

Gradient Descent

Regularization

Other NNs

Summary

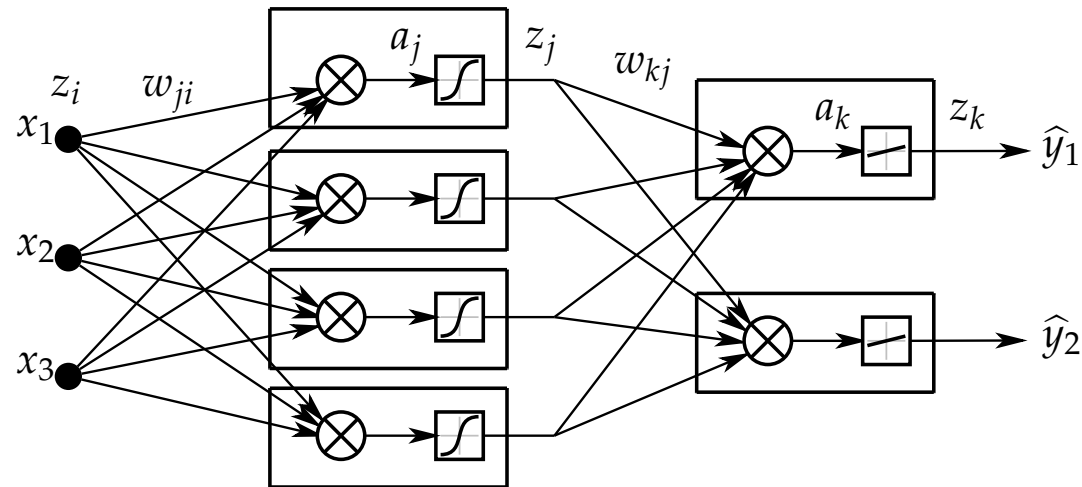

Forward propagation:

- Given all the weights w and activation functions g , we can for a single input vector x easily compute the estimate of the output vector \hat{y} by iteratively evaluating in individual layers:

$$a_j = \sum_{i \in \text{Src}(j)} w_{ji} z_i \quad (1)$$

$$z_j = g(a_j) \quad (2)$$

- Note that
 - z_i in (1) may be the *outputs of hidden layers neurons* or the *inputs* x_i , and
 - z_j in (2) may be the *outputs of hidden layers neurons* or the *outputs* \hat{y}_k .



Activation functions

Intro

Multilayer FFN

- MLP
- MLP: A look inside
- **Activation functions**
- MLP: Learning
- Quiz
- BP
- BP algorithm
- BP: Example
- BP Efficiency
- Loss functions

Gradient Descent

Regularization

Other NNs

Summary

- Identity: $g(a) = a$
- Binary step: $g(a) = \begin{cases} 0 & \text{for } a < 0, \\ 1 & \text{for } a \geq 0 \end{cases}$
- Logistic (sigmoid): $g(a) = \sigma(a) = \frac{1}{1+e^{-a}}$
- Hyperbolic tangent: $g(a) = \tanh(a) = 2\sigma(a) - 1$
- Rectified Linear unit (ReLU): $g(a) = \max(0, a) = \begin{cases} 0 & \text{for } a < 0, \\ a & \text{for } a \geq 0 \end{cases}$
- Leaky ReLU: $g(a) = \begin{cases} 0.01a & \text{for } a < 0, \\ a & \text{for } a \geq 0 \end{cases}$
- ...



MLP: Learning

How to train a NN (i.e. find suitable w) given the training data set (X, y) ?

Intro

Multilayer FFN

- MLP
- MLP: A look inside
- Activation functions
- **MLP: Learning**
- Quiz
- BP
- BP algorithm
- BP: Example
- BP Efficiency
- Loss functions

Gradient Descent

Regularization

Other NNs

Summary



MLP: Learning

How to train a NN (i.e. find suitable w) given the training data set (X, y) ?

In principle, MLP can be trained in the same way as a single-layer NN using a gradient descent algorithm:

- Define the loss function to be minimized, e.g. squared error loss:

$$J(w) = \sum_{i=1}^{|T|} E(w, x^{(i)}, y^{(i)}) = \frac{1}{2} \sum_{i=1}^{|T|} \sum_{k=1}^C (y_{ik} - \hat{y}_{ik})^2, \quad \text{where}$$

$$E(w, x, y) = \frac{1}{2} \sum_{k=1}^C (y_k - \hat{y}_k)^2.$$

$|T|$ is the size of the training set, and C is the number of outputs of NN.

- Compute the gradient of the loss function w.r.t. individual weights:

$$\nabla E(w) = \left(\frac{\partial E}{\partial w_1}, \frac{\partial E}{\partial w_2}, \dots, \frac{\partial E}{\partial w_W} \right).$$

- Make a step in the direction opposite to the gradient to update the weights:

$$w_d \longleftarrow w_d - \eta \frac{\partial E}{\partial w_d} \quad \text{for } d = 1, \dots, W.$$

How to compute the individual derivatives?

Intro

Multilayer FFN

- MLP
- MLP: A look inside
- Activation functions
- **MLP: Learning**
- Quiz
- BP
- BP algorithm
- BP: Example
- BP Efficiency
- Loss functions

Gradient Descent

Regularization

Other NNs

Summary



Quiz

Let's have a simple linear NN with 2 inputs, 2 outputs, and 4 weights (parameters):

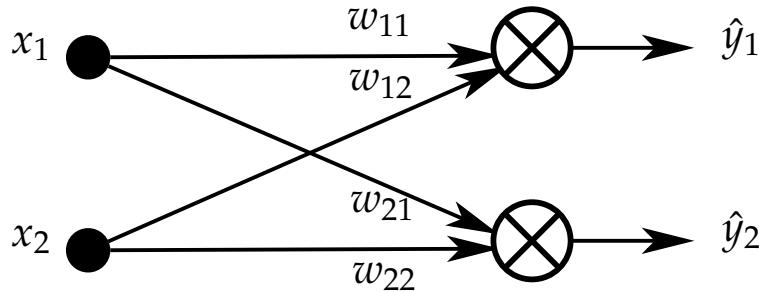

The current values of the weights are

$$w_{11} = 1,$$

$$w_{12} = 2,$$

$$w_{21} = 3, \text{ and}$$

$$w_{22} = 4.$$

We would like to update the weights of the NN using a single example from the training dataset $(\mathbf{x}, \mathbf{y}) = (x_1, x_2, y_1, y_2) = (1, 2, 1, 10)$. We use squared error loss.

Which of the weights will change the most with this update? I.e., which of $\frac{\partial E}{\partial w_{ji}}$ is of the biggest size?

- A** w_{11}
- B** w_{12}
- C** w_{21}
- D** w_{22}

Intro

Multilayer FFN

- MLP
- MLP: A look inside
- Activation functions
- MLP: Learning
- **Quiz**
- BP
- BP algorithm
- BP: Example
- BP Efficiency
- Loss functions

Gradient Descent

Regularization

Other NNs

Summary

Error backpropagation

Error backpropagation (BP) is the algorithm for efficient computation of $\frac{\partial E}{\partial w_d}$.

Error backpropagation

Error backpropagation (BP) is the algorithm for efficient computation of $\frac{\partial E}{\partial w_d}$.

Consider only $\frac{\partial E}{\partial w_d}$ because

$$\frac{\partial J}{\partial w_d} = \sum_n \frac{\partial}{\partial w_d} E(\mathbf{w}, \mathbf{x}^{(n)}, \mathbf{y}^{(n)}).$$

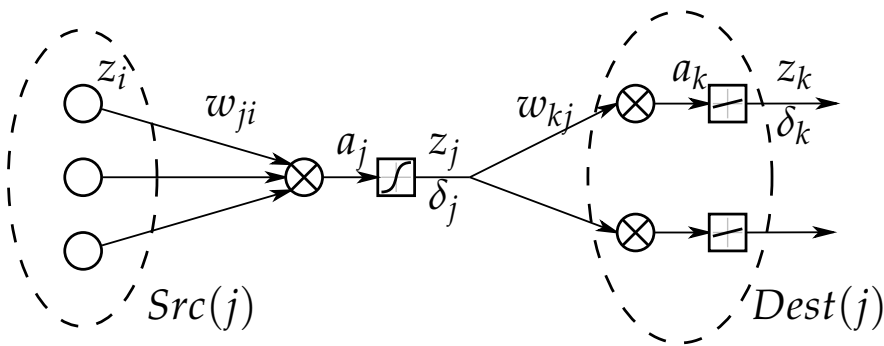

E depends on w_{ji} only via a_j :

$$\frac{\partial E}{\partial w_{ji}} = \frac{\partial E}{\partial a_j} \frac{\partial a_j}{\partial w_{ji}} \quad (3)$$

Let's introduce the so called *error* δ_j :

$$\delta_j = \frac{\partial E}{\partial a_j} \quad (4)$$

From (1) we can derive:

$$\frac{\partial a_j}{\partial w_{ji}} = z_i \quad (5)$$

Substituting (4) and (5) into (3):

$$\frac{\partial E}{\partial w_{ji}} = \delta_j z_i, \quad (6)$$

where

- δ_j is the error of the neuron on the output of the edge $i \rightarrow j$, and
- z_i is the input of the edge $i \rightarrow j$.

“The more we excite edge $i \rightarrow j$ (big z_i) and the larger is the error of the neuron on its output (large δ_j), the more sensitive is the loss function E to the change of w_{ji} .”

- All values z_i are known from forward pass,
- to compute the gradient, we need to compute all δ_j .

Error backpropagation (cont.)

We need to compute the *errors* δ_j .

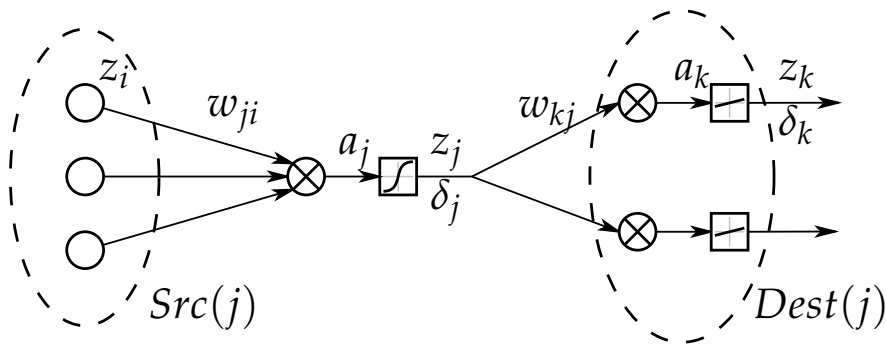

For the output layer:

$$\delta_k = \frac{\partial E}{\partial a_k}$$

E depends on a_k only via $\hat{y}_k = g(a_k)$:

$$\delta_k = \frac{\partial E}{\partial a_k} = \frac{\partial E}{\partial \hat{y}_k} \frac{\partial \hat{y}_k}{\partial a_k} = g'(a_k) \frac{\partial E}{\partial \hat{y}_k} \quad (7)$$

“The error δ_k is distributed to δ_j in the lower layer according to the weight w_{kj} (which is the speed of growth of the linear combination a_k) and according to the size of $g'(a_j)$ (which is the speed of growth of the activation function).”

For the hidden layers:

$$\delta_j = \frac{\partial E}{\partial a_j}$$

E depends on a_j via all a_k ,
 $k \in \text{Dest}(j)$:

$$\begin{aligned} \delta_j &= \frac{\partial E}{\partial a_j} = \sum_{k \in \text{Dest}(j)} \frac{\partial E}{\partial a_k} \frac{\partial a_k}{\partial a_j} = \\ &= \sum_{k \in \text{Dest}(j)} \delta_k \frac{\partial a_k}{\partial a_j} = \\ &= g'(a_j) \sum_{k \in \text{Dest}(j)} w_{kj} \delta_k, \end{aligned} \quad (8)$$

because

$$a_k = \sum_{j \in \text{Src}(k)} w_{kj} z_j = \sum_{j \in \text{Src}(k)} w_{kj} g(a_j),$$

$$\text{and thus } \frac{\partial a_k}{\partial a_j} = w_{kj} g'(a_j)$$



Error backpropagation algorithm

Algorithm 1: Error Backpropagation: the computation of derivatives $\frac{\partial E}{\partial w_d}$.

Intro

Multilayer FFN

- MLP
- MLP: A look inside
- Activation functions
- MLP: Learning
- Quiz
- BP
- **BP algorithm**
- BP: Example
- BP Efficiency
- Loss functions

Gradient Descent

Regularization

Other NNs

Summary

1 **begin**

2 Perform a forward pass for observation x . This will result in values of all a_j and z_j for the vector x .

3 Evaluate the error δ_k for the output layer (using Eq. 7):

$$\delta_k = g'(a_k) \frac{\partial E}{\partial \hat{y}_k}$$

4 Using Eq. 8, propagate the errors δ_k back to get all the remaining δ_j :

$$\delta_j = g'(a_j) \sum_{k \in \text{Dest}(j)} w_{kj} \delta_k$$

5 Using Eq. 6, evaluate all the derivatives to get the whole gradient:

$$\frac{\partial E}{\partial w_{ji}} = \delta_j z_i$$



Error backpropagation: Example

NN with a single hidden layer:

- Squared error loss: $E = \frac{1}{2} \sum_{k=1}^C (y_k - \hat{y}_k)^2$
- Activation func. in the output layer: identity $g_k(a_k) = a_k$, $g'_k(a_k) = 1$
- Activation func. in the hidden layer: sigmoidal $g_j(a_j) = \frac{1}{1 + e^{-a_j}}$, $g'_j(a_j) = z_j(1 - z_j)$

Intro

Multilayer FFN

- MLP
- MLP: A look inside
- Activation functions
- MLP: Learning
- Quiz
- BP
- BP algorithm
- **BP: Example**
- BP Efficiency
- Loss functions

Gradient Descent

Regularization

Other NNs

Summary



Error backpropagation: Example

NN with a single hidden layer:

- Squared error loss: $E = \frac{1}{2} \sum_{k=1}^C (y_k - \hat{y}_k)^2$
- Activation func. in the output layer: identity $g_k(a_k) = a_k$, $g'_k(a_k) = 1$
- Activation func. in the hidden layer: sigmoidal $g_j(a_j) = \frac{1}{1 + e^{-a_j}}$, $g'_j(a_j) = z_j(1 - z_j)$

Computing the errors δ :

- Output layer: $\delta_k = g'_k(a_k) \frac{\partial E}{\partial \hat{y}_k} = -(y_k - \hat{y}_k)$
- Hidden layer: $\delta_j = g'_j(a_j) \sum_{k \in \text{Dest}(j)} w_{kj} \delta_k = z_j(1 - z_j) \sum_{k \in \text{Dest}(j)} w_{kj} \delta_k$

Computation of all the partial derivatives:

$$\frac{\partial E}{\partial w_{ji}} = \delta_j x_i$$

$$\frac{\partial E}{\partial w_{kj}} = \delta_k z_j$$

Online learning:

$$w_{ji} \leftarrow w_{ji} - \eta \delta_j x_i$$
$$w_{kj} \leftarrow w_{kj} - \eta \delta_k z_j$$

Batch learning:

$$w_{ji} \leftarrow w_{ji} - \eta \sum_{n=1}^{|T|} \delta_j^{(n)} x_i^{(n)}$$
$$w_{kj} \leftarrow w_{kj} - \eta \sum_{n=1}^{|T|} \delta_k^{(n)} z_j^{(n)}$$

Intro

Multilayer FFN

- MLP
- MLP: A look inside
- Activation functions
- MLP: Learning
- Quiz
- BP
- BP algorithm
- **BP: Example**
- BP Efficiency
- Loss functions

Gradient Descent

Regularization

Other NNs

Summary



Error backpropagation efficiency

Let W be the number of weights in the network (the number of parameters being optimized).

- The evaluation of E for a single observation requires $\mathcal{O}(W)$ operations (evaluation of $w_{ji}z_i$ dominates, evaluation of $g(a_j)$ is neglected).

We need to compute W derivatives for each observation:

- Classical approach:
 - Find explicit equations for $\frac{\partial E}{\partial w_{ji}}$.
 - To compute each of them $\mathcal{O}(W)$ steps are required.
 - In total, $\mathcal{O}(W^2)$ steps for a single training example.
- Backpropagation:
 - Requires only $\mathcal{O}(W)$ steps for a single training example.

Intro

Multilayer FFN

- MLP
- MLP: A look inside
- Activation functions
- MLP: Learning
- Quiz
- BP
- BP algorithm
- BP: Example
- **BP Efficiency**
- Loss functions

Gradient Descent

Regularization

Other NNs

Summary

Loss functions

Task	Suggested loss function
Binary classification	Cross-entropy: $J = - \sum_{i=1}^{ T } [y^{(i)} \log \hat{y}^{(i)} + (1 - y^{(i)}) \log(1 - \hat{y}^{(i)})]$
Multinomial classification	Multinomial cross-entropy: $J = - \sum_{i=1}^{ T } \sum_{k=1}^C I(y^{(i)} = k) \log \hat{y}_k^{(i)}$
Regression	Squared error: $J = \sum_{i=1}^{ T } (y^{(i)} - \hat{y}^{(i)})^2$
Multi-output regression	Squared error: $J = \sum_{i=1}^{ T } \sum_{k=1}^C (y_k^{(i)} - \hat{y}_k^{(i)})^2$

Note: often, mean errors are used.

- Computed as the average w.r.t. the number of training examples $|T|$.
- The optimum is in the same point, of course.



Gradient Descent



Learning rate annealing

Task: find such parameters w^* which minimize the model cost over the training set, i.e.

$$w^* = \arg \min_w J(w; X, y)$$

Gradient descent: $w^{(t+1)} = w^{(t)} - \eta^{(t)} \nabla J(w^{(t)})$,

where $\eta^{(t)} > 0$ is the **learning rate** or **step size** at iteration t .

Learning rate decay:

- Decrease the learning rate in time.
- **Step decay:** reduce the learning rate every few iterations by certain factor, e.g. $\frac{1}{2}$.
- **Exponential decay:** $\eta^{(t)} = \eta_0 e^{-kt}$
- **Hyperbolic decay:** $\eta^{(t)} = \frac{\eta_0}{1+kt}$

Intro

Multilayer FFN

Gradient Descent

- Learning rate
- Weights update
- Momentum
- GD improvements

Regularization

Other NNs

Summary



Weights update

When should we update the weights?

■ Batch learning:

- Compute the gradient w.r.t. all the training examples (epoch).
- Several epochs are required to train the network.
- Inefficient for redundant datasets.

■ Online learning:

- Compute the gradient w.r.t. a single training example only.
- **Stochastic Gradient Descent (SGD)**
- Converges almost surely to local minimum when $\eta^{(t)}$ decreases appropriately in time.

■ Mini-batch learning:

- Compute the gradient w.r.t. a small subset of the training examples.
- A compromise between the above 2 extremes.

Intro

Multilayer FFN

Gradient Descent

- Learning rate
- **Weights update**
- Momentum
- GD improvements

Regularization

Other NNs

Summary



Momentum

Momentum

- Perform the update in an analogy to physical systems: a particle with certain mass and velocity gets acceleration from the gradient (“force”) of the loss function:

$$\mathbf{v}^{(t+1)} = \mu \mathbf{v}^{(t)} + \eta^{(t)} \nabla J(\mathbf{w}^{(t)})$$

$$\mathbf{w}^{(t+1)} = \mathbf{w}^{(t)} + \mathbf{v}^{(t+1)}$$

- SGD with momentum tends to keep traveling in the same direction, preventing oscillations.
- It builds the velocity in directions with consistent (but possibly small) gradient.

Nesterov’s Momentum

- Slightly different update equations:

$$\mathbf{v}^{(t+1)} = \mu \mathbf{v}^{(t)} + \eta^{(t)} \nabla J(\mathbf{w}^{(t)} + \mu \mathbf{v}^{(t)})$$

$$\mathbf{w}^{(t+1)} = \mathbf{w}^{(t)} + \mathbf{v}^{(t+1)}$$

- Classic momentum corrects the velocity using gradient at $\mathbf{w}^{(t)}$; Nesterov uses gradient at $\mathbf{w}^{(t)} + \mu \mathbf{v}^{(t)}$ which is more similar to $\mathbf{w}^{(t+1)}$.
- Stronger theoretical convergence guarantees; slightly better in practice.

Intro

Multilayer FFN

Gradient Descent

- Learning rate
- Weights update
- **Momentum**
- GD improvements

Regularization

Other NNs

Summary



Further gradient descent improvements

Intro

Multilayer FFN

Gradient Descent

- Learning rate
- Weights update
- Momentum
- GD improvements

Regularization

Other NNs

Summary

Resilient Propagation (Rprop)

- $\frac{\partial J}{\partial w_d}$ may differ a lot for different parameters w_d .
- Rprop does not use the value, only its *sign* to adapt the step size for each weight separately.
- Often, an order of magnitude faster than basic GD.
- Does not work well for mini-batches.

Adaptive Gradient (Adagrad)

- Idea: Reduce learning rates for parameters having high values of gradient.

Root Mean Square Propagation (RMSprop)

- Similar to AdaGrad, but employs a moving average of the gradient values.
- Can be seen as a generalization of Rprop, can work also with mini-batches.

Adaptive Moment Estimation (Adam)

- Improvement of RMSprop.
- Uses moving averages of gradients and their second moments.

See also:

- <http://sebastianruder.com/optimizing-gradient-descent/>
- <http://cs231n.github.io/neural-networks-3/>
- <http://cs231n.github.io/assets/nn3/opt2.gif>, <http://cs231n.github.io/assets/nn3/opt1.gif>



Regularization



Overfitting and regularization

Overfitting in NN is often characterized by weight values that are very large in magnitude. How to deal with it?

- Get more data.
- Use a simpler model (less hidden layers, less neurons, different activation functions).
- Use *regularization* (penalize the model complexity).

Intro

Multilayer FFN

Gradient Descent

Regularization

- Ridge
- Dropout

Other NNs

Summary



Overfitting and regularization

Overfitting in NN is often characterized by weight values that are very large in magnitude. How to deal with it?

- Get more data.
- Use a simpler model (less hidden layers, less neurons, different activation functions).
- Use *regularization* (penalize the model complexity).

Ridge regularization:

- Modified loss function, e.g. for squared error:

$$J'(\mathbf{w}) = J(\mathbf{w}) + \text{penalty} = \frac{1}{2m} \sum_{i=1}^m \left(y^{(i)} - \mathbf{x}^{(i)} \mathbf{w}^T \right)^2 + \frac{\alpha}{m} \sum_{d=1}^D w_d^2.$$

- Modified weight update in GD:

$$w_d \leftarrow w_d - \eta \frac{\partial J'}{\partial w_d} = \underbrace{\left(1 - \frac{\eta \alpha}{m} \right)}_{\text{weight decay}} w_d - \eta \frac{\partial J}{\partial w_d},$$

where η is the learning rate, α is the regularization strength, m is the number of examples in the batch.

- The biases (weights connected to constant 1) should not be regularized!

Intro

Multilayer FFN

Gradient Descent

Regularization

- Ridge
- Dropout

Other NNs

Summary



Dropout

- Idea: Average many NNs, share weights to make it computationally feasible.
- For each training example, omit each neuron with certain probability (often $p = 0.5$).
- This is like sampling from 2^N networks where N is the number of units.
- Only a small part of the 2^N networks is actually sampled.
- Prevents coadaptation of feature vectors.

Intro

Multilayer FFN

Gradient Descent

Regularization

- Ridge
- Dropout

Other NNs

Summary

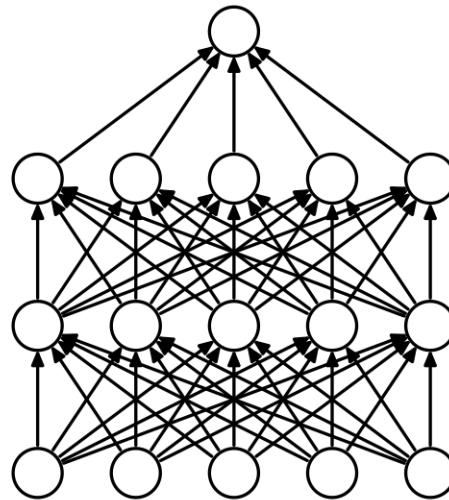

(a) Standard Neural Net

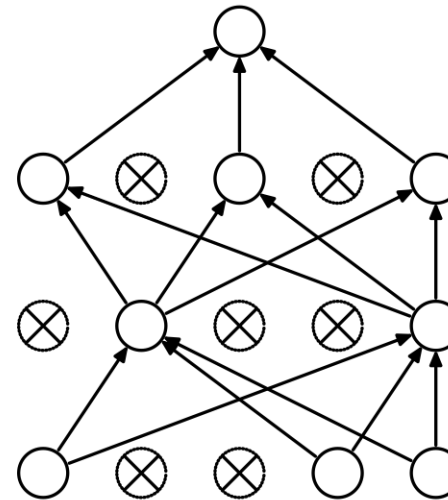

(b) After applying dropout.

Srivastava et al.: A Simple Way to Prevent Neural Networks from Overfitting, 2014



Other types of Neural Networks



Beyond MLPs

MLPs are only one type of neural networks. Other types of FFNNs include:

- **Radial basis functions (RBF) nets.** Neurons contain prototypes, forward propagation resembles a (smoothed) nearest neighbors method.
- **Autoencoders.** Learn a compact representation of the input data.
- **Convolutional nets.** Replace the fully-connected layer with a convolutional layer that has smaller number of weights and reuses them for many input variables. Aimed at image processing.
- ...

Recurrent nets contain also *feedback connections*.

- They preserve a kind of *state* of the network.
- Simple recurrent architectures: **Jordan, Elman**. Network output or state used together with input in the next iteration.
- **Hopfield net.** Used as associative memory.
- **Long short-term memory (LSTM).** Suitable for processing data sequences in time.
- ...

Other architectures:

- **Kohonen's self-organizing maps (SOM).** Used for unsupervised learning.
- **Neural gas.** Used e.g. to approximately solve the traveling salesperson problem.
- ...

[Intro](#)

[Multilayer FFN](#)

[Gradient Descent](#)

[Regularization](#)

[Other NNs](#)

• [Beyond MLPs](#)

[Summary](#)



Summary

Competencies

After this lecture, a student shall be able to ...

1. describe the model of a simple neuron, and explain its relation to multivariate regression and logistic regression;
2. explain how to find weights of a single neuron using gradient descent (GD) algorithm;
3. derive the update equations used in GD to optimize the weights of a single neuron for various loss functions and various activation functions;
4. describe a multilayer feedforward network and discuss its usage and characteristics;
5. compare the use of GD in case of a single neuron and in case of NN, discuss similarities and differences;
6. explain the error backpropagation (BP) algorithm — its purpose and principle;
7. implement BP algorithm for a simple NN, and suggest how the implementation should be modified to allow application for complex networks;
8. discuss the purpose of various modifications of GD algorithm (learning rate decay, weight update schedule, momentum, ...);
9. discuss the regularization options for NN (weight decay, dropout);
10. be aware of other types of NNs, not only feedforward nets.