

Chapter 4 (Part 1): Non-Parametric Classification (Sections 4.1-4.3)

- Introduction
- Density Estimation
- Parzen Windows

Introduction

- All Parametric densities are unimodal (have a single local maximum), whereas many practical problems involve multimodal densities
- Nonparametric procedures can be used with arbitrary distributions and without the assumption that the forms of the underlying densities are known
- There are two types of nonparametric methods:
 - Estimating $P(x / \omega_j)$
 - Bypass probability and go directly to a-posteriori probability estimation

Density Estimation

- Basic idea:
- Probability that a vector x will fall in region R is:

$$P = \int_{\mathfrak{R}} p(x') dx' \quad (1)$$

- P is a smoothed (or averaged) version of the density function $p(x)$ if we have a sample of size n ; therefore, the probability that k points fall in R is then:

$$P_k = \binom{n}{k} P^k (1 - P)^{n-k} \quad (2)$$

and the expected value for k is:

$$E(k) = nP \quad (3)$$

ML estimation of $P = \theta$

$$\text{Max}_{\theta}(P_k | \theta) \text{ is reached for } \hat{\theta} = \frac{k}{n} \cong P$$

Therefore, the ratio k/n is a good estimate for the probability P and hence for the density function p .

$p(x)$ is continuous and that the region R is so small that p does not vary significantly within it, we can write:

$$\int_{\mathfrak{R}} p(x') dx' \cong p(x)V \quad (4)$$

where x is a point within R and V the volume enclosed by R .

Combining equation (1) , (3) and (4) yields:

$$p(x) \cong \frac{k/n}{V}$$

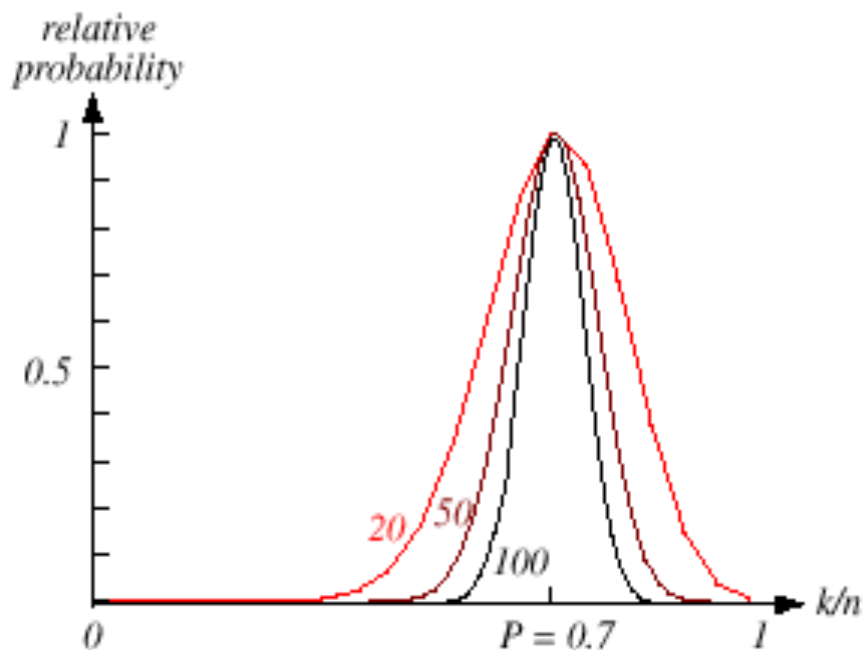

FIGURE 4.1. The relative probability an estimate given by Eq. 4 will yield a particular value for the probability density, here where the true probability was chosen to be 0.7. Each curve is labeled by the total number of patterns n sampled, and is scaled to give the same maximum (at the true probability). The form of each curve is binomial, as given by Eq. 2. For large n , such binomials peak strongly at the true probability. In the limit $n \rightarrow \infty$, the curve approaches a delta function, and we are guaranteed that our estimate will give the true probability. From: Richard O. Duda, Peter E. Hart, and David G. Stork, *Pattern Classification*. Copyright © 2001 by John Wiley & Sons, Inc.

Density Estimation (cont.)

- Justification of equation (4)

$$\int_{\mathcal{R}} p(x') dx' \cong p(x)V \quad (4)$$

We assume that $p(x)$ is continuous and that region R is so small that p does not vary significantly within R . Since $p(x) = \text{constant}$, it is not a part of the sum.

$$\int_{\mathfrak{R}} p(x') dx' = p(x') \int_{\mathfrak{R}} dx' = p(x') \int_{\mathfrak{R}} 1_{\mathfrak{R}}(x) dx' = p(x') \mu(\mathfrak{R})$$

Where: $\mu(R)$ is: a surface in the Euclidean space R^2
 a volume in the Euclidean space R^3
 a hypervolume in the Euclidean space R^n

Since $p(x) \cong p(x') = \text{constant}$, therefore in the Euclidean space R^3 :

$$\int_{\mathfrak{R}} p(x') dx' \cong p(x) \cdot V$$

$$\text{and } p(x) \cong \frac{k}{nV}$$

- Condition for convergence

The fraction $k/(nV)$ is a space averaged value of $p(x)$.
 $p(x)$ is obtained only if V approaches zero.

$$\lim_{V \rightarrow 0, k=0} p(x) = 0 \text{ (if } n = \text{fixed)}$$

This is the case where no samples are included in R :
it is an uninteresting case!

$$\lim_{V \rightarrow 0, k \neq 0} p(x) = \infty$$

In this case, the estimate diverges: it is an
uninteresting case!

- The volume V needs to approach 0 anyway if we want to use this estimation
 - Practically, V cannot be allowed to become small since the number of samples is always limited
 - One will have to accept a certain amount of variance in the ratio k/n
 - Theoretically, if an unlimited number of samples is available, we can circumvent this difficulty

To estimate the density of x , we form a sequence of regions

R_1, R_2, \dots containing x : the first region contains one sample, the second two samples and so on.

Let V_n be the volume of R_n , k_n the number of samples falling in R_n and $p_n(x)$ be the n^{th} estimate for $p(x)$:

$$p_n(x) = (k_n/n)/V_n \quad (7)$$

Three necessary conditions should apply if we want $p_n(x)$ to converge to $p(x)$,

$$1) \lim_{n \rightarrow \infty} V_n = 0$$

$$2) \lim_{n \rightarrow \infty} k_n = \infty$$

$$3) \lim_{n \rightarrow \infty} k_n / n = 0$$

There are two different ways of obtaining sequences of regions that satisfy these conditions:

(a) Shrink an initial region where $V_n = 1/\sqrt{n}$ and show that

$$p_n(x) \xrightarrow{n \rightarrow \infty} p(x)$$

This is called “the Parzen-window estimation method”

(b) Specify k_n as some function of n , such as $k_n = \sqrt{n}$; the volume V_n is grown until it encloses k_n neighbors of x . This is called “the k_n -nearest neighbor estimation method”

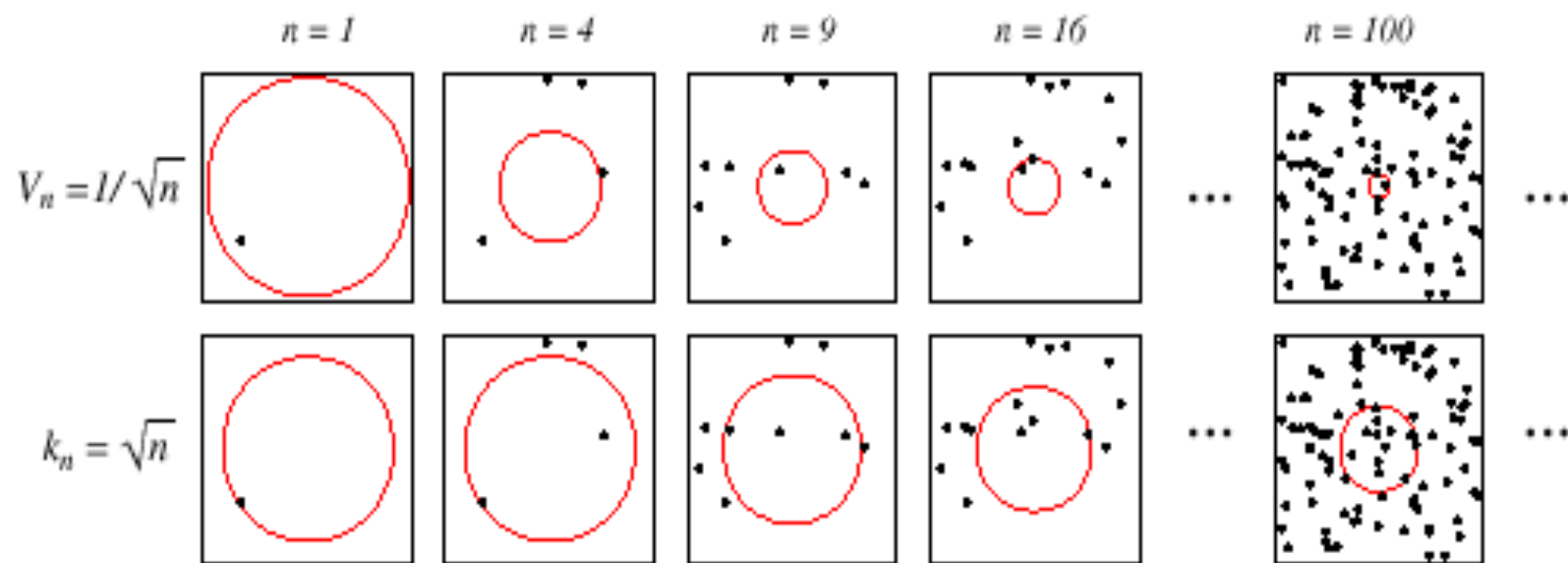
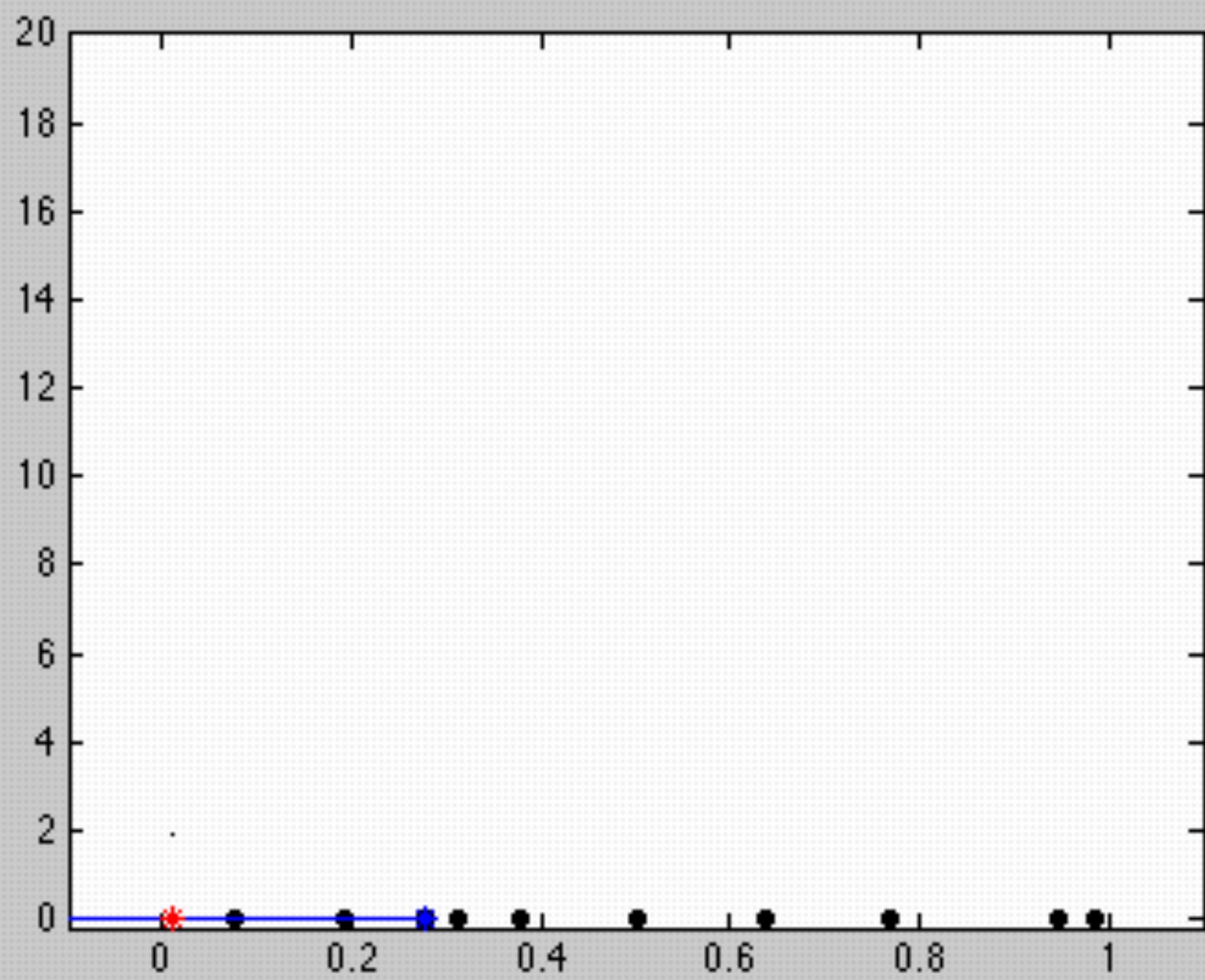

FIGURE 4.2. There are two leading methods for estimating the density at a point, here at the center of each square. The one shown in the top row is to start with a large volume centered on the test point and shrink it according to a function such as $V_n = 1/\sqrt{n}$. The other method, shown in the bottom row, is to decrease the volume in a data-dependent way, for instance letting the volume enclose some number $k_n = \sqrt{n}$ of sample points. The sequences in both cases represent random variables that generally converge and allow the true density at the test point to be calculated. From: Richard O. Duda, Peter E. Hart, and David G. Stork, *Pattern Classification*. Copyright © 2001 by John Wiley & Sons, Inc.



Parzen Windows

- Parzen-window approach to estimate densities assume that the region R_n is a d-dimensional hypercube

$V_n = h_n^d$ (h_n : length of the edge of R_n)

Let $\varphi(u)$ be the following window function :

$$\varphi(u) = \begin{cases} 1 & |u_j| \leq \frac{1}{2} \quad j = 1, \dots, d \\ 0 & \text{otherwise} \end{cases}$$

- $\varphi((x-x_i)/h_n)$ is equal to unity if x_i falls within the hypercube of volume V_n centered at x and equal to zero otherwise.

- The number of samples in this hypercube is:

$$k_n = \sum_{i=1}^{i=n} \varphi\left(\frac{\mathbf{x} - \mathbf{x}_i}{h_n}\right)$$

By substituting k_n in equation (7), we obtain the following estimate:

$$\mathbf{p}_n(\mathbf{x}) = \frac{1}{n} \sum_{i=1}^{i=n} \frac{1}{v_n} \varphi\left(\frac{\mathbf{x} - \mathbf{x}_i}{h_n}\right)$$

$P_n(x)$ estimates $p(x)$ as an average of functions of x and the samples (x_i) ($i = 1, \dots, n$). These functions φ can be general!

- Illustration
- The behavior of the Parzen-window method
- Case where $p(x) \rightarrow N(0,1)$

Let $\varphi(u) = (1/\sqrt{2\pi}) \exp(-u^2/2)$ and $h_n = h_1/\sqrt{n}$ ($n > 1$)

(h_1 : known parameter)

Thus:

$$p_n(\mathbf{x}) = \frac{1}{n} \sum_{i=1}^n \frac{1}{h_n} \varphi\left(\frac{\mathbf{x} - \mathbf{x}_i}{h_n}\right)$$

is an average of normal densities centered at the samples \mathbf{x}_i .

- Numerical results:

For $n = 1$ and $h_1 = 1$

$$p_1(\mathbf{x}) = \varphi(\mathbf{x} - \mathbf{x}_1) = \frac{1}{\sqrt{2\pi}} e^{-1/2 (\mathbf{x} - \mathbf{x}_1)^2} \rightarrow N(\mathbf{x}_1, 1)$$

For $n = 10$ and $h = 0.1$, the contributions of the individual samples are clearly observable !

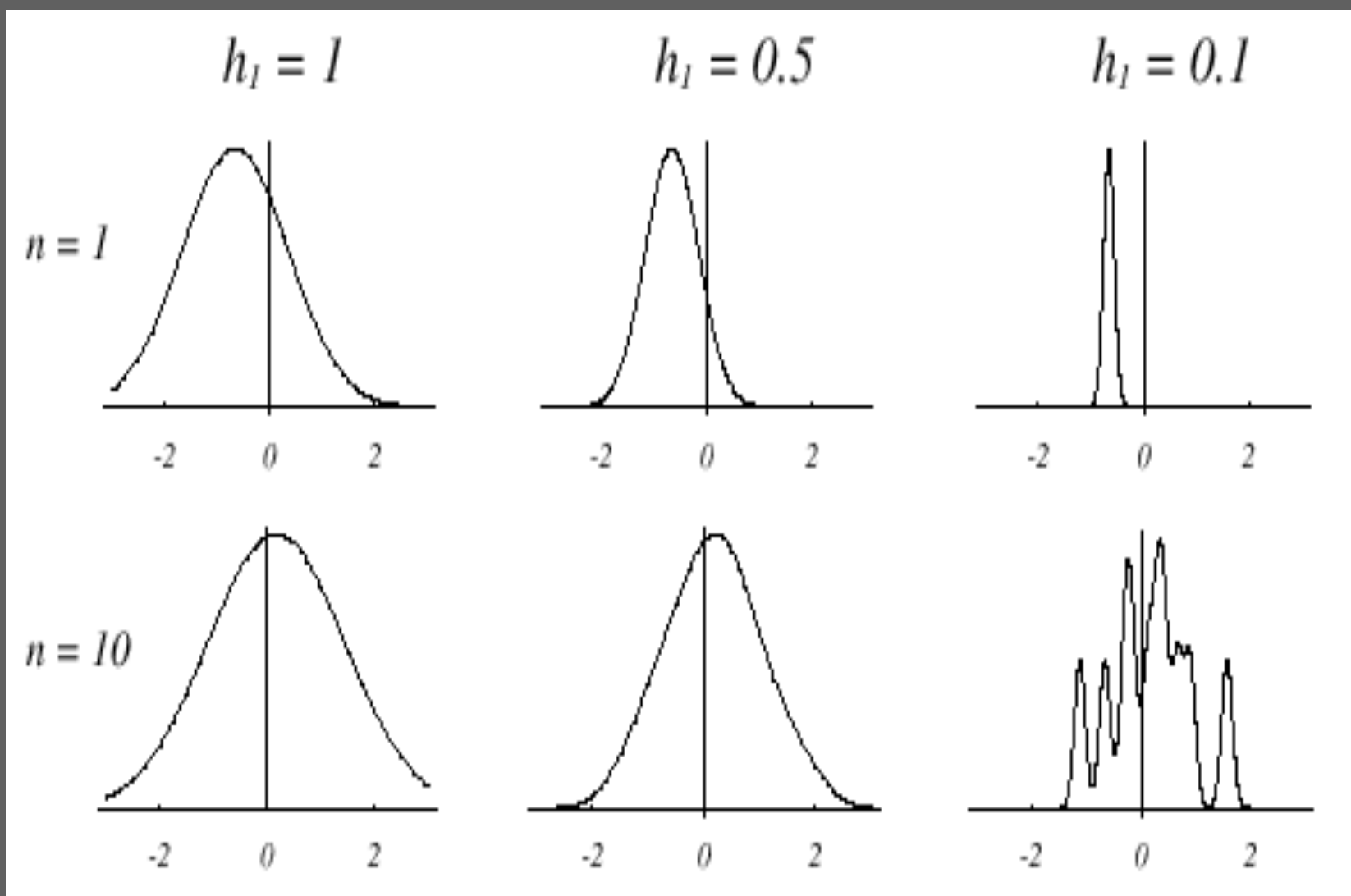

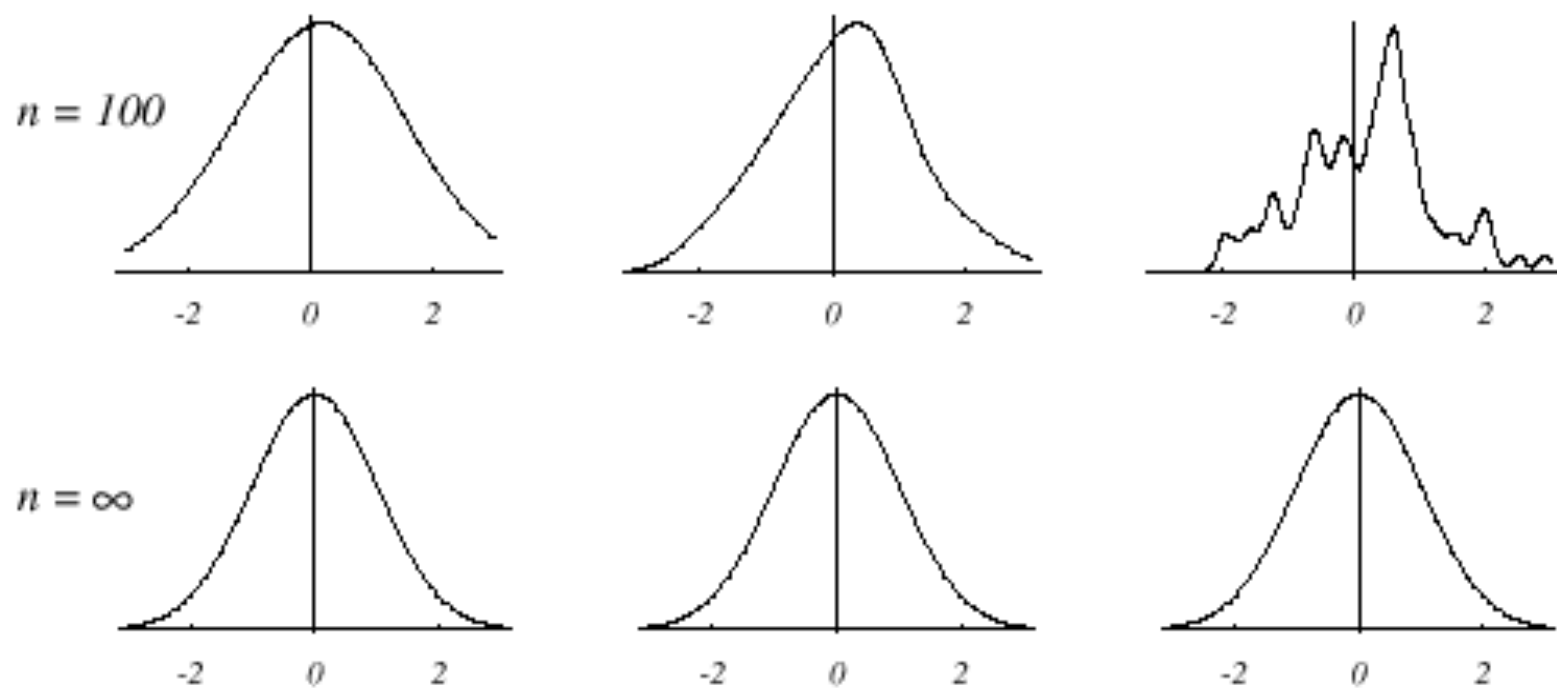
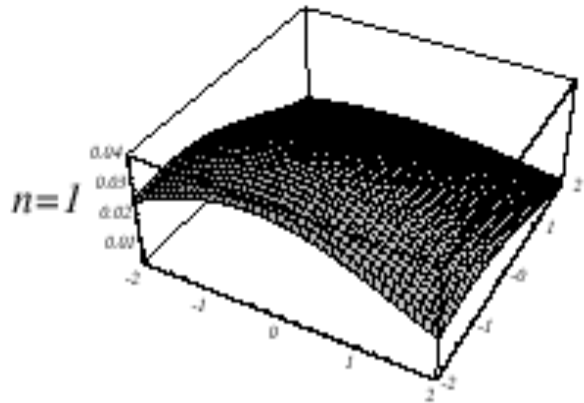

FIGURE 4.5. Parzen-window estimates of a univariate normal density using different window widths and numbers of samples. The vertical axes have been scaled to best show the structure in each graph. Note particularly that the $n = \infty$ estimates are the same (and match the true density function), regardless of window width. From: Richard O. Duda, Peter E. Hart, and David G. Stork, *Pattern Classification*. Copyright © 2001 by John Wiley & Sons, Inc.

Analogous results are also obtained in two dimensions as illustrated:

$h_1=2$



$h_1=1$

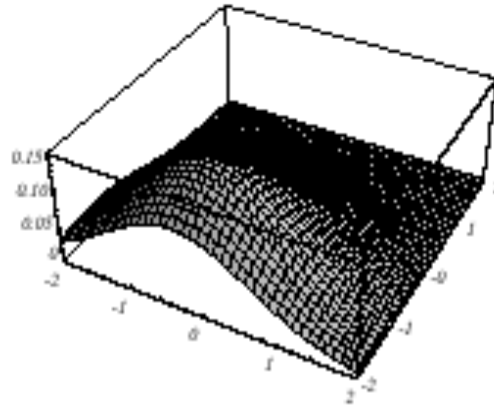

$h_1=0.5$

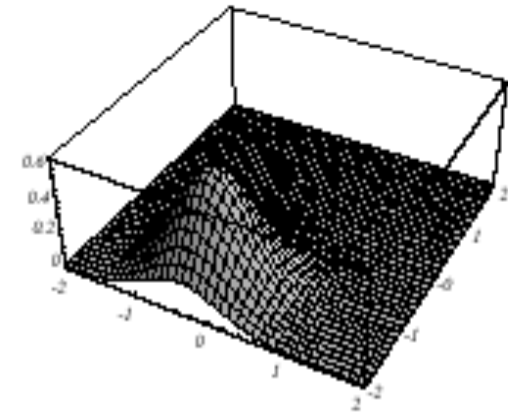

$n=10$

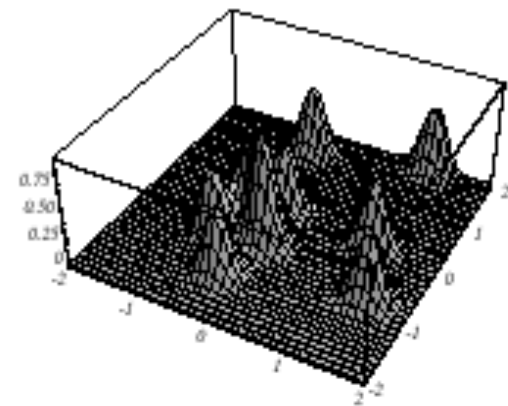
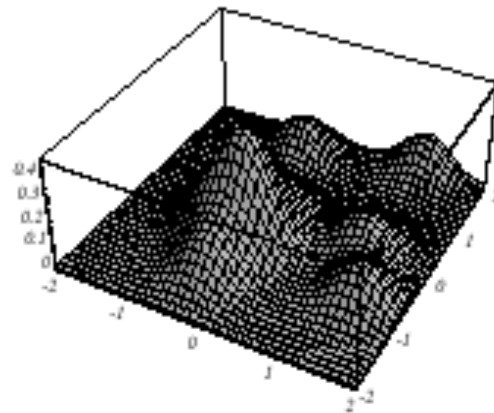
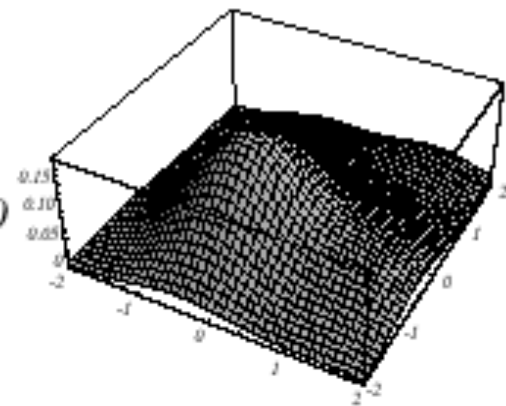

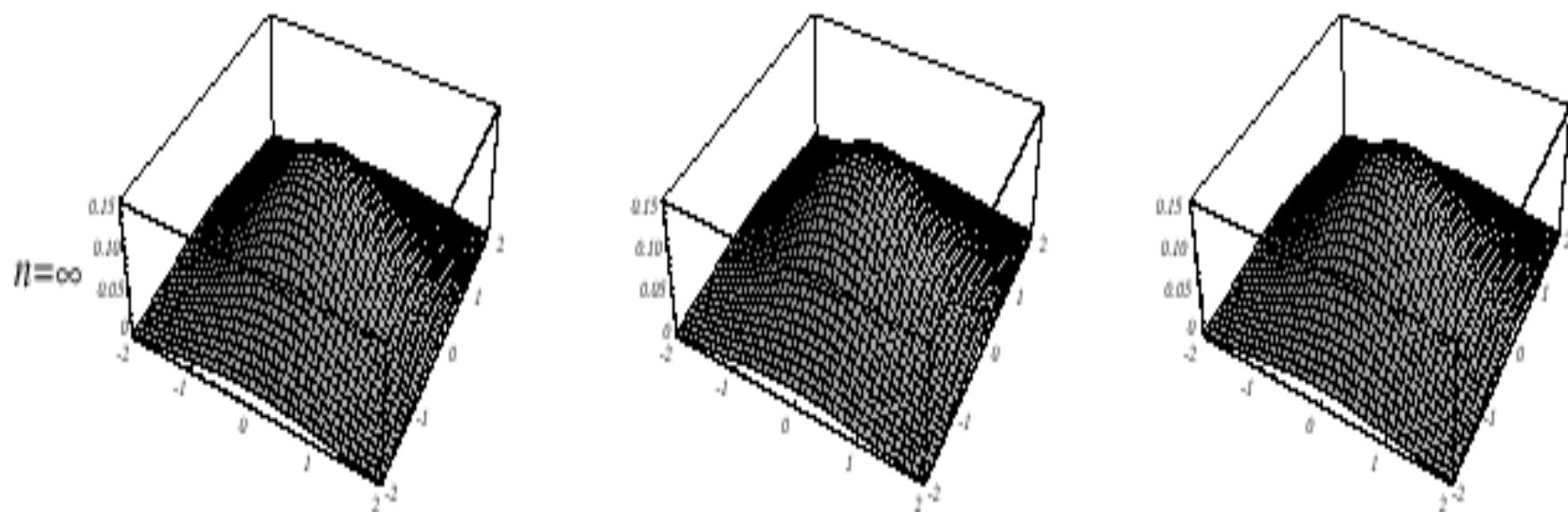
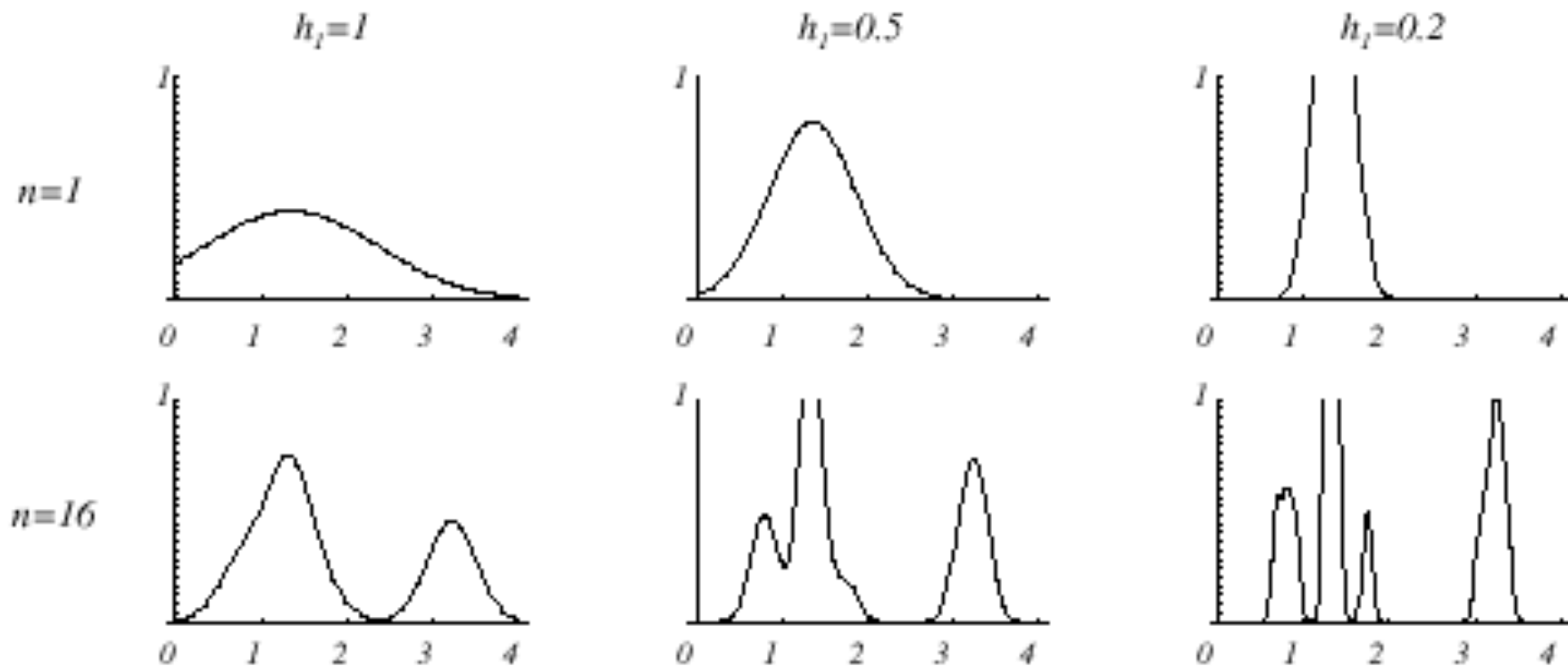

FIGURE 4.6. Parzen-window estimates of a bivariate normal density using different window widths and numbers of samples. The vertical axes have been scaled to best show the structure in each graph. Note particularly that the $n = \infty$ estimates are the same (and match the true distribution), regardless of window width. From: Richard O. Duda, Peter E. Hart, and David G. Stork, *Pattern Classification*. Copyright © 2001 by John Wiley & Sons, Inc.

- Case where $p(x) = \lambda_1 \cdot U(a,b) + \lambda_2 \cdot T(c,d)$
(unknown density) (mixture of a uniform and a triangle density)



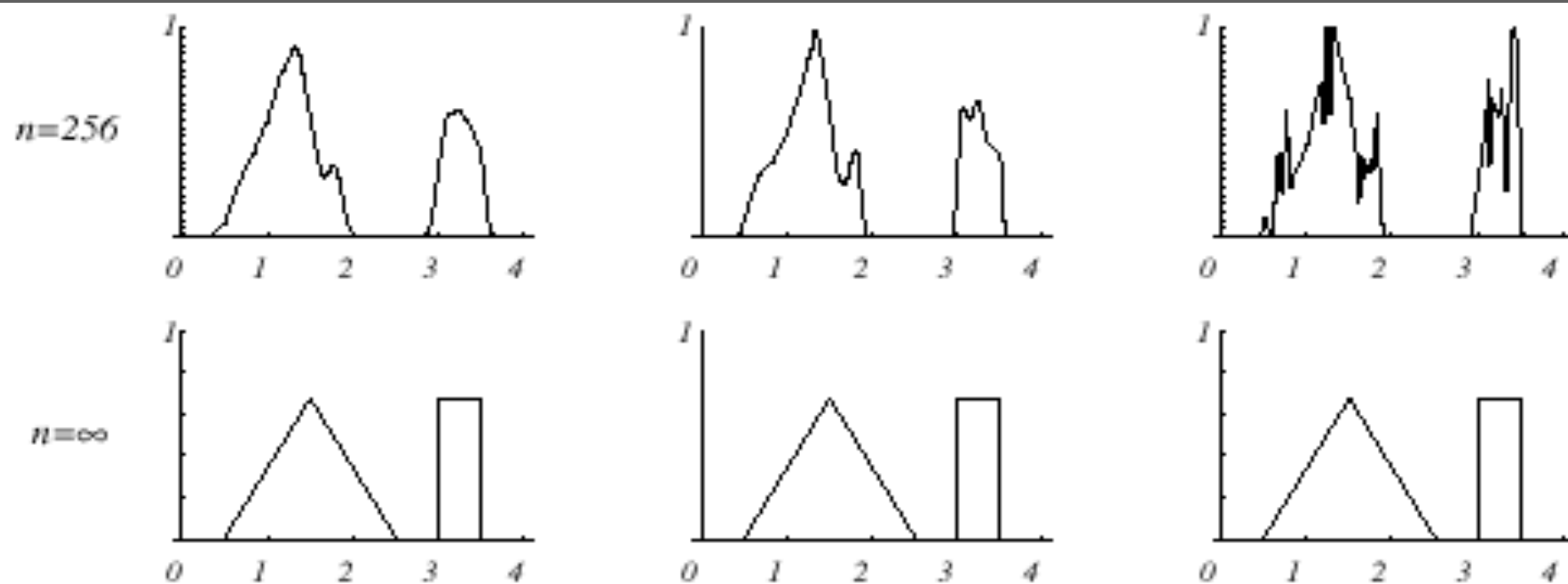

FIGURE 4.7. Parzen-window estimates of a bimodal distribution using different window widths and numbers of samples. Note particularly that the $n = \infty$ estimates are the same (and match the true distribution), regardless of window width. From: Richard O. Duda, Peter E. Hart, and David G. Stork, *Pattern Classification*. Copyright © 2001 by John Wiley & Sons, Inc.

- Classification example

In classifiers based on Parzen-window estimation:

- We estimate the densities for each category and classify a test point by the label corresponding to the maximum posterior
- The decision region for a Parzen-window classifier depends upon the choice of window function as illustrated in the following figure.

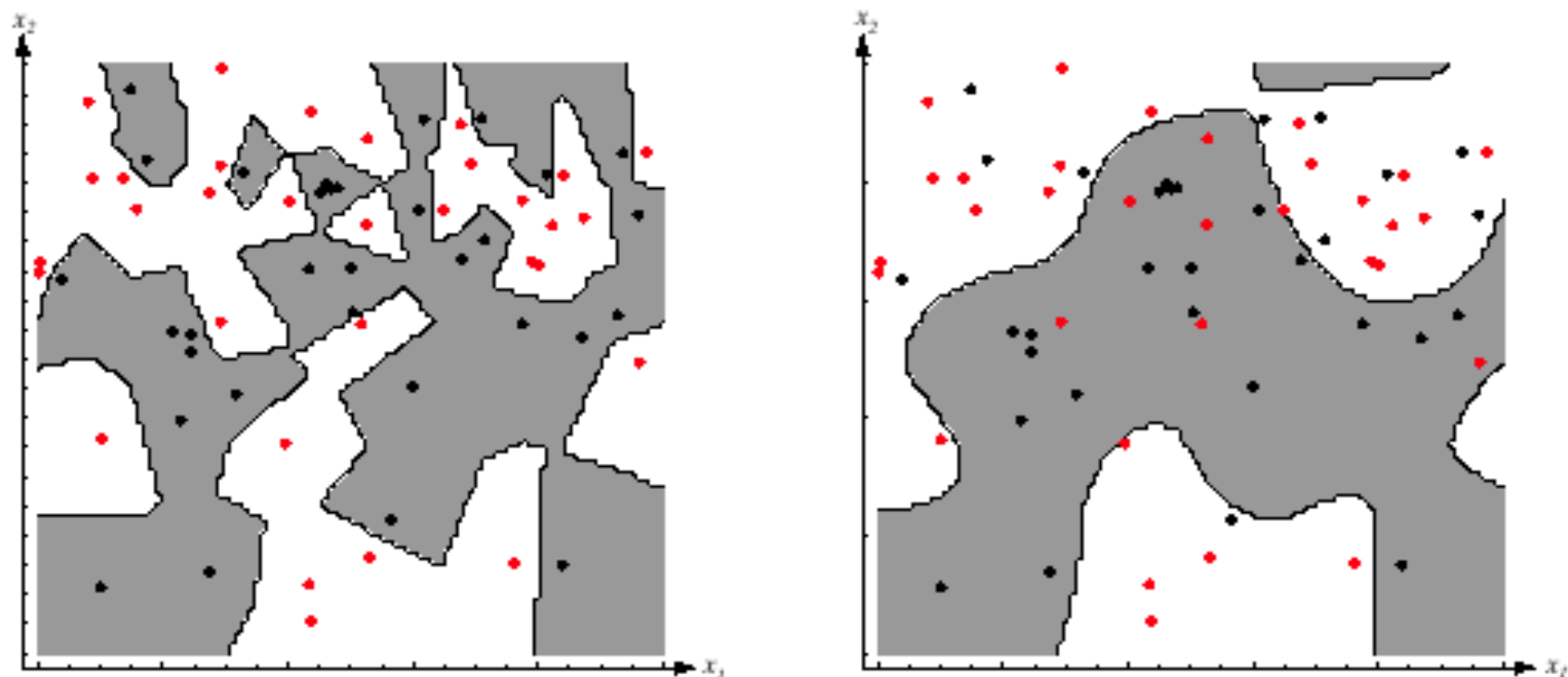

FIGURE 4.8. The decision boundaries in a two-dimensional Parzen-window dichotomizer depend on the window width h . At the left a small h leads to boundaries that are more complicated than for large h on same data set, shown at the right. Apparently, for these data a small h would be appropriate for the upper region, while a large h would be appropriate for the lower region; no single window width is ideal overall. From: Richard O. Duda, Peter E. Hart, and David G. Stork, *Pattern Classification*. Copyright © 2001 by John Wiley & Sons, Inc.