



Algoritmizace

Marko Genyk-Berezovskyj, Daniel Průša

2010 – 2022

Dnešní témata

- Průchod stromem do šířky
- Průchod grafem do hloubky a do šířky
- Čtvrtá domácí úloha

slido



Úvodní zvolání

ⓘ Start presenting to display the poll results on this slide.

Z minula: průchod stromem do hloubky

Okamžik tisku ○

Směr pohybu

```
void listInorder(Node node) :  
    if (node == null) return;  
    listInorder(node.left);  
    print(node.key);  
    listInorder(node.right);
```

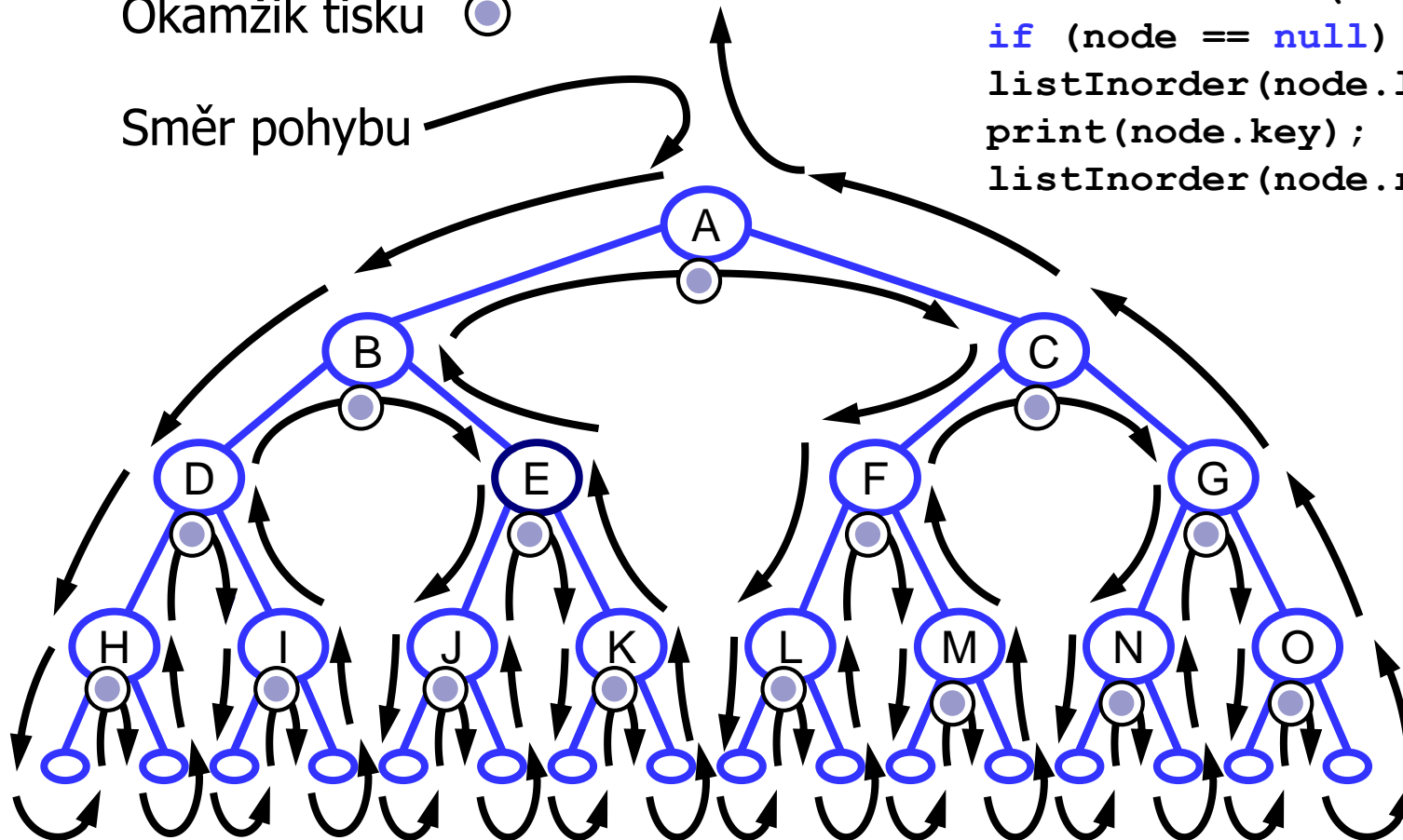

Výstup

H D I B J E K A L F M C N G O

Průchod stromem do šířky

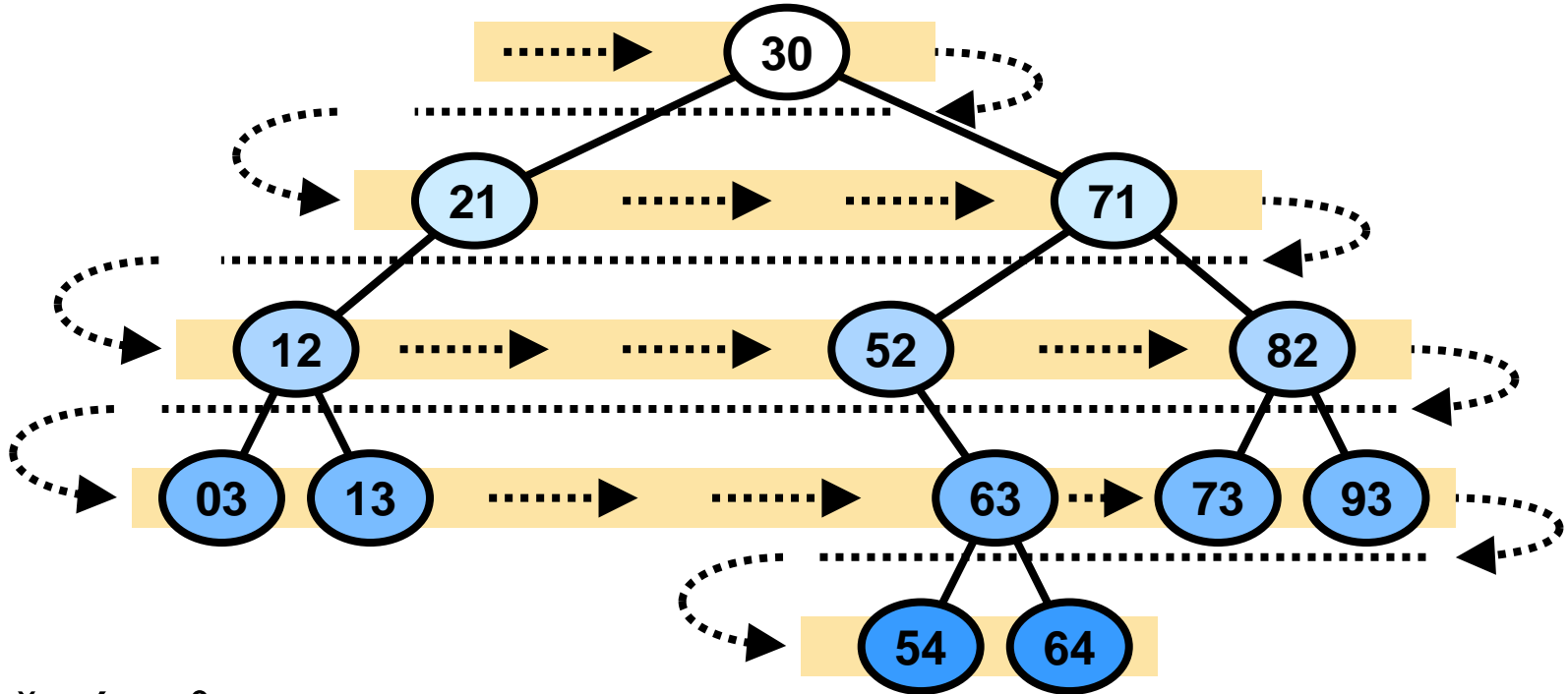

Pořadí uzlů

30	21	71	12	52	82	03	13	63	73	93	54	64
----	----	----	----	----	----	----	----	----	----	----	----	----

Struktura stromu ani rekurzivní přístup tento průchod nepodporují.

Fronta

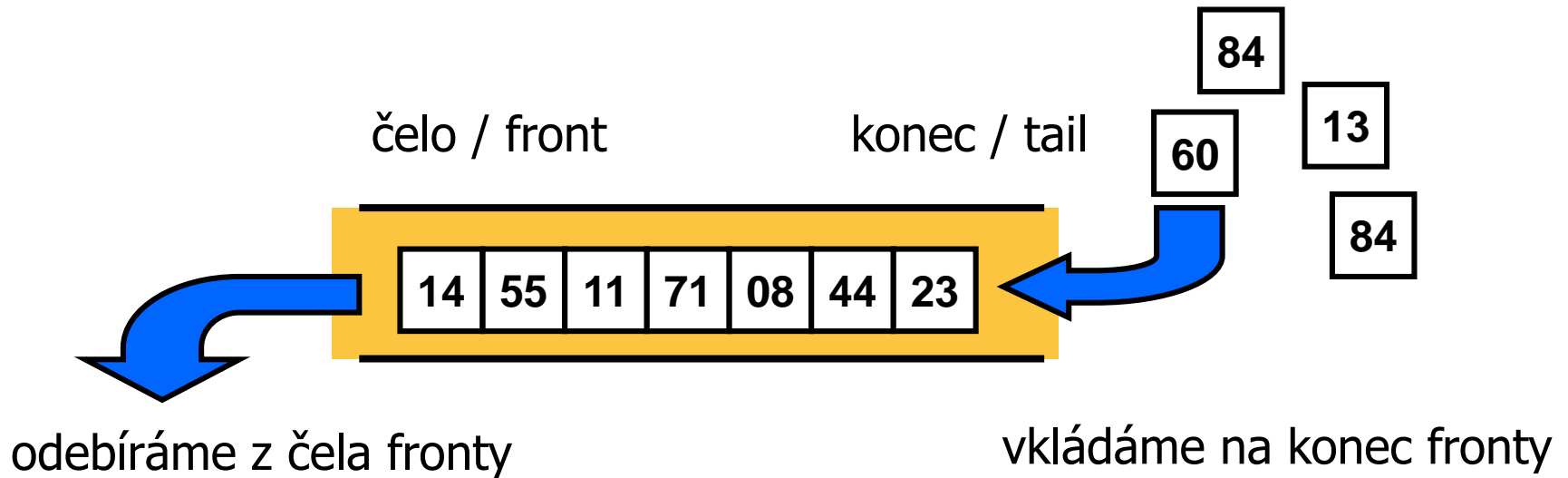

`java.util.LinkedList`

```
addLast(element)
removeFirst()
getFirst()
isEmpty()
```

`queue` (C++ Standard Template Library)

```
queue::push(element)
queue::pop()
queue::front()
queue::empty()
```

Cyklická implementace fronty polem



Prázdná fronta
v poli pevné délky



Vlož 24, 11, 90, 43, 70.

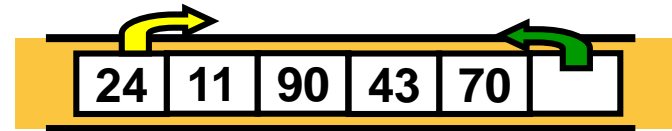

Odeber, odeber, odeber.

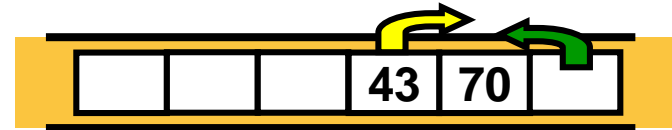

Vlož 10, 20.

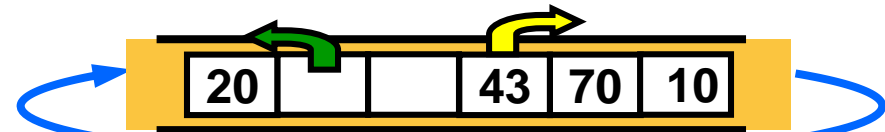

Odeber, odeber.

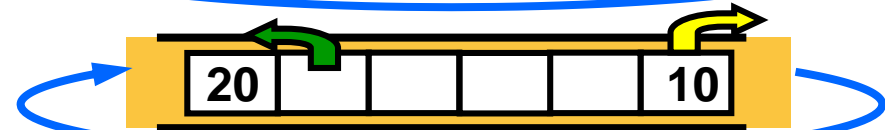

Vlož 55, 22, 33.

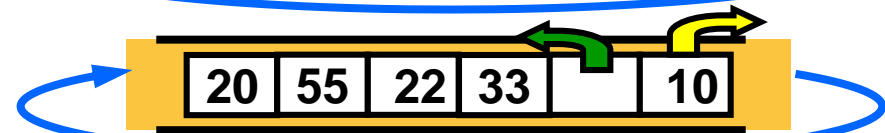

Odeber, odeber.

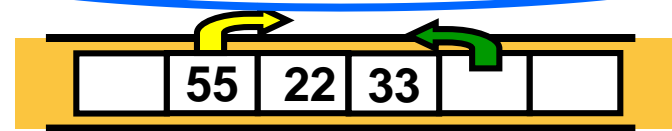

Průchod stromem do šířky

Inicializace:

Vytvoř prázdnou frontu



Do fronty vlož kořen stromu



Čelo

Konec

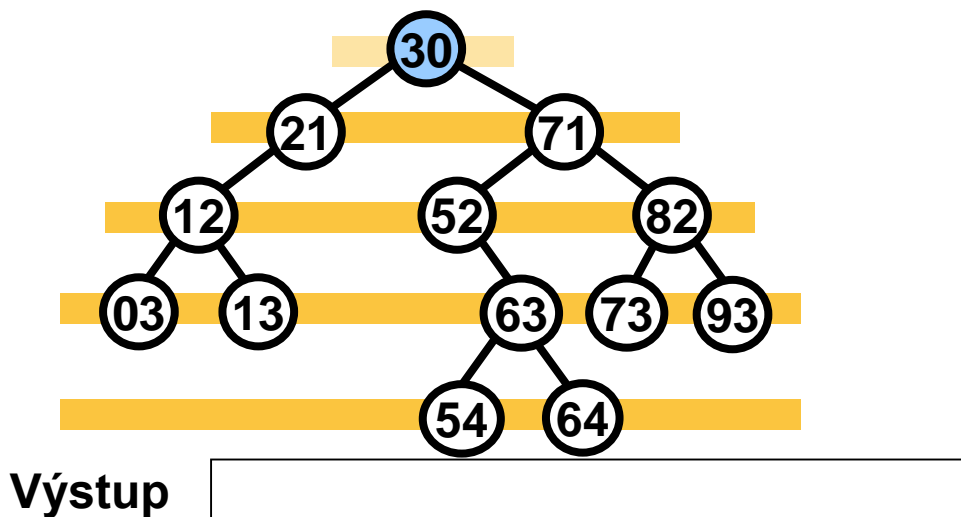

Hlavní cyklus

Dokud není fronta prázdná, opakuj:

1. Odeber první uzel z fronty a zpracuj ho.
2. Do fronty vlož jeho potomky, pokud existují.

Průchod stromem do šířky

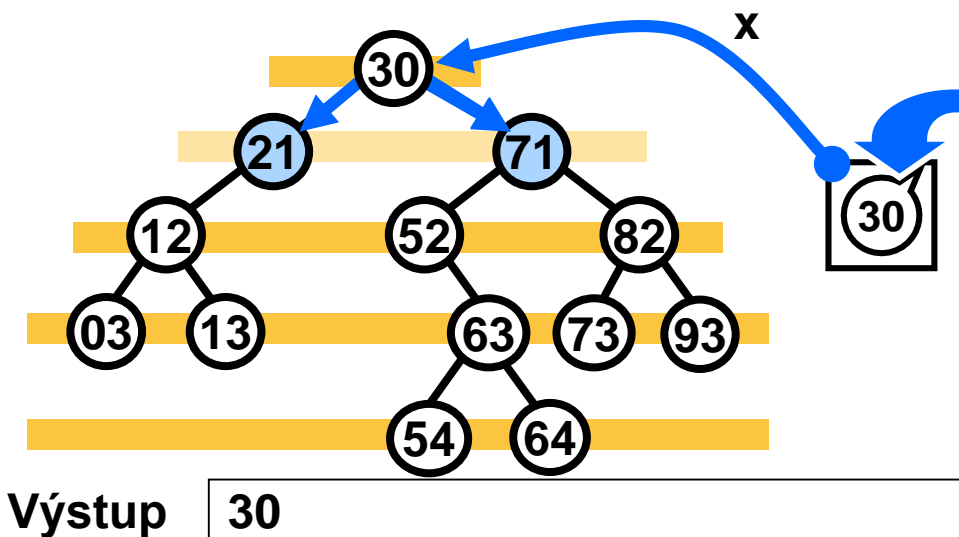

1. $x = \text{Odeber}()$, $\text{tisk}(x.\text{key})$.

2. $\text{Vlož}(x.\text{left})$, $\text{vlož}(x.\text{right})$. *)



*) pokud existuje

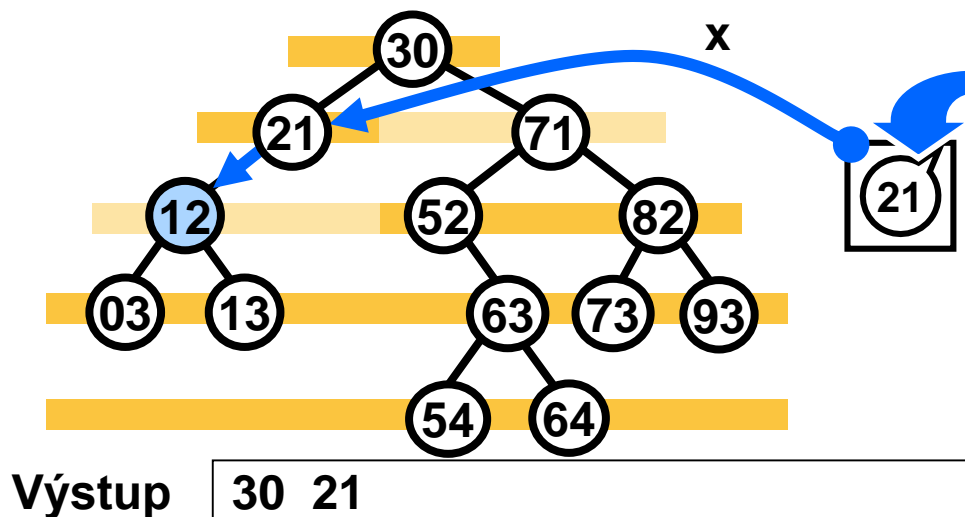

1. $x = \text{Odeber}()$, $\text{tisk}(x.\text{key})$.

2. $\text{Vlož}(x.\text{left})$, $\text{vlož}(x.\text{right})$. *)



Průchod stromem do šířky

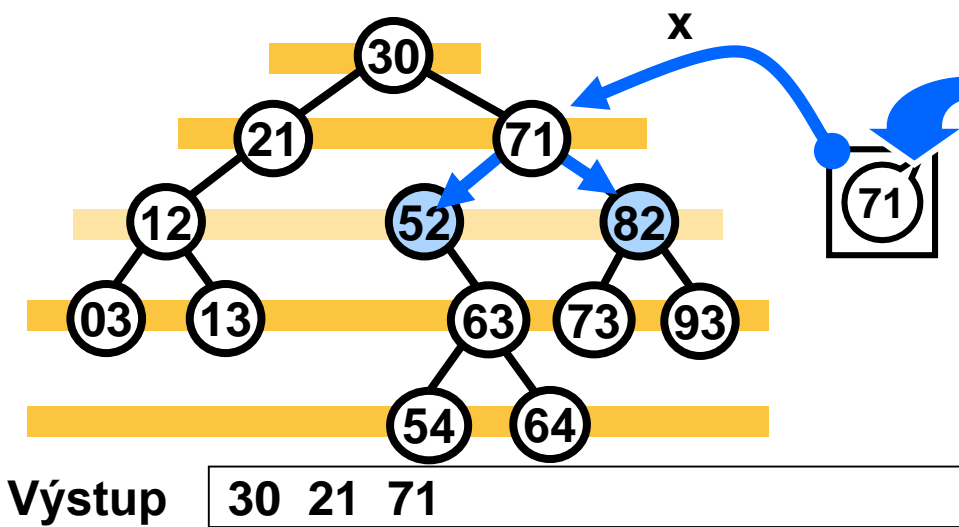

1. $x = \text{Odeber}()$, $\text{tisk}(x.\text{key})$.

2. $\text{Vlož}(x.\text{left})$, $\text{vlož}(x.\text{right})$. *)

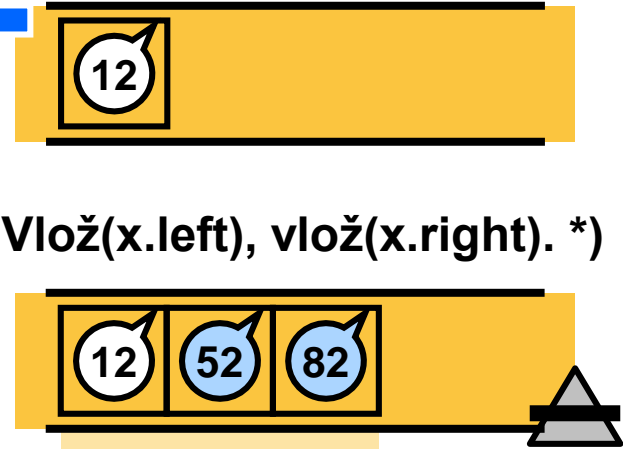

1. $x = \text{Odeber}()$, $\text{tisk}(x.\text{key})$.

2. $\text{Vlož}(x.\text{left})$, $\text{vlož}(x.\text{right})$. *)

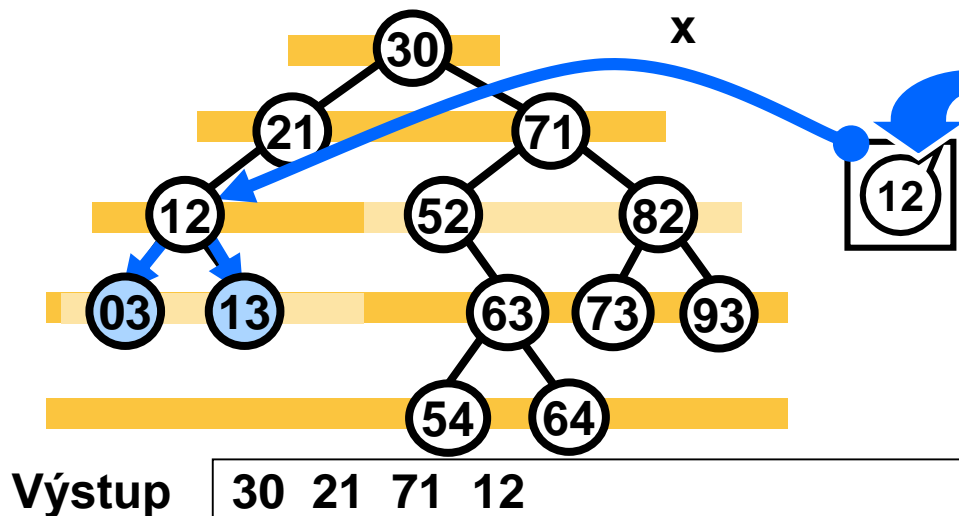

*) pokud existuje

Průchod stromem do šířky

...

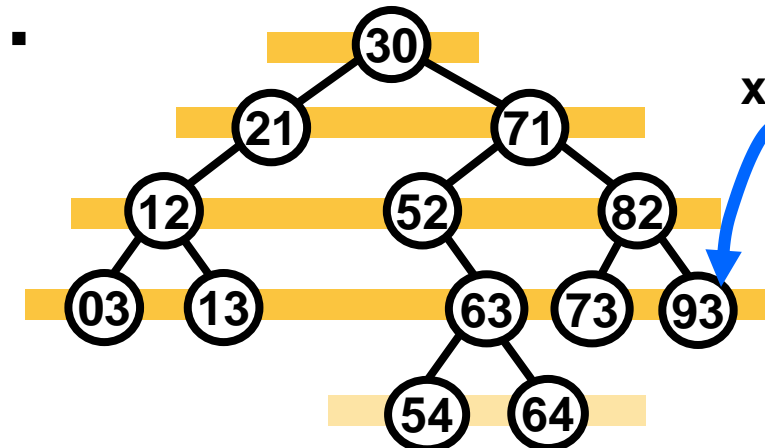

1. $x = \text{Odeber}()$, $\text{tisk}(x.\text{key})$.



2. Vlož($x.\text{left}$), vlož($x.\text{right}$). *)



Výstup 30 21 71 12 52 82 03 13 63 73 93

*) pokud existuje

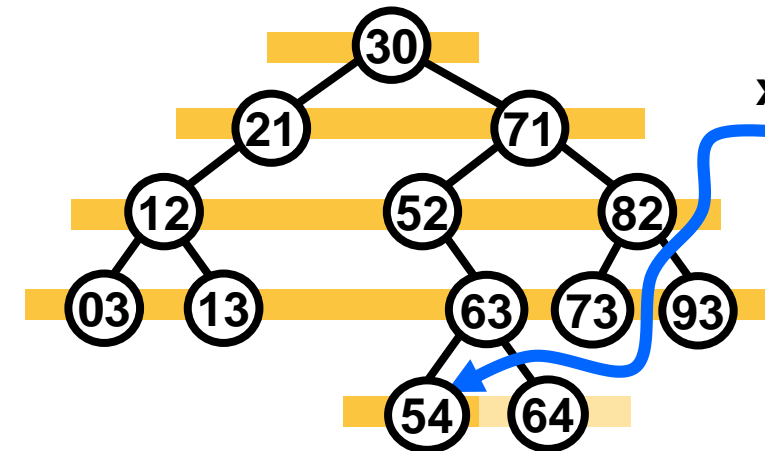

1. $x = \text{Odeber}()$, $\text{tisk}(x.\text{key})$.



2. Vlož($x.\text{left}$), vlož($x.\text{right}$). *)



Výstup 30 21 71 12 52 82 03 13 63 73 93 54

Průchod stromem do šířky

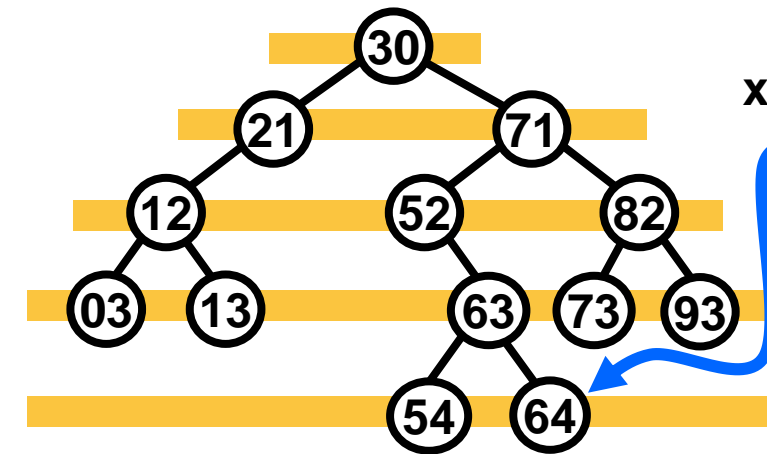

1. $x = \text{Odeber}(), \text{tisk}(x.\text{key}).$

2. $\text{Vlož}(x.\text{left}), \text{vlož}(x.\text{right}).$ *)

*) pokud existuje

Výstup 30 21 71 12 52 82 03 13 63 73 93 54 64

Fronta je prázdná,
průchod stromem končí.

V neprázdné frontě jsou vždy právě

-- některé (třeba všechny) uzly jednoho patra

-- a všichni potomci těch uzlů tohoto patra, které už nejsou ve frontě.

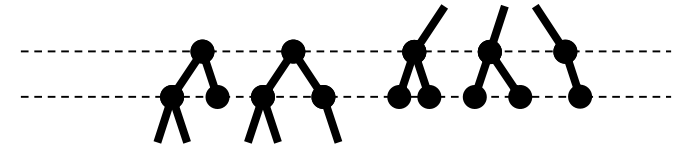

Někdy jsou ve frontě přesně všechny uzly jednoho patra. Viz výše.



Průchod stromem do šířky

```
void listBreadth (Node node) {  
    if (node == null) return;  
    Queue q = new Queue();           // create queue  
    q.push(node);                    // init queue  
    while (!q.empty()) {  
        node = q.pop();  
        print(node.key);             // process node  
        if (node.left != null) q.push(node.left);  
        if (node.right != null) q.push(node.right);  
    }  
}
```



Jakou má průchod stromem do šířky časovou složitost?

slido



**Jakou má průchod do
šířky stromem s 'n' uzly
časovou složitost?**

ⓘ Start presenting to display the poll results on this slide.

slido



Audience Q&A Session

① Start presenting to display the audience questions on this slide.

Průchod grafem

Průchody stromem zobecníme pro orientované i neorientované grafy.

$$G_1 = (V, E_1)$$

$$V = \{a, b, c, d, e\}$$

$$E_1 = \left\{ \begin{array}{l} \{a, b\}, \{b, c\}, \{b, e\}, \\ \{e, c\}, \{d, e\}, \{a, d\} \end{array} \right\}$$

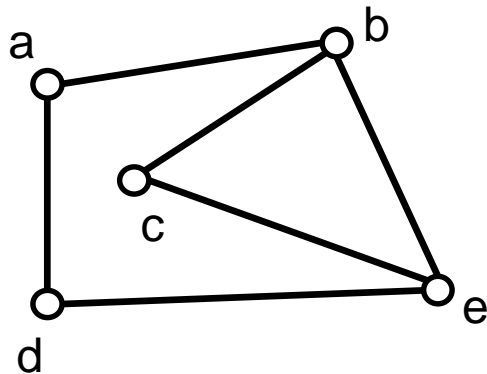

$$G_2 = (V, E_2)$$

$$V = \{a, b, c, d, e\}$$

$$E_2 = \left\{ \begin{array}{l} (a, b), (b, c), (b, e), \\ (c, e), (e, d), (d, a) \end{array} \right\}$$

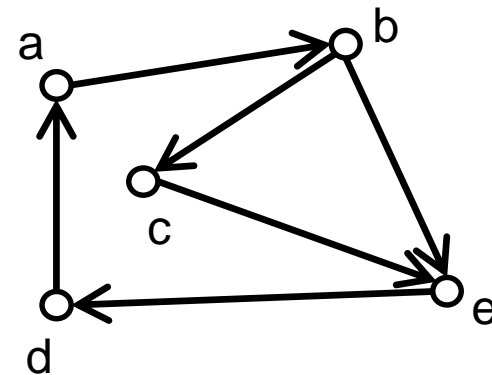

Použití: hledání komponent souvislosti, cyklů, hranově nejkratší cesty, ...

Reprezentace grafu v paměti

Matice sousednosti:

	a	b	c	d	e
a	0	1	0	1	0
b	1	0	1	0	1
c	0	1	0	0	1
d	1	0	0	0	1
e	0	1	1	1	0

Seznam sousedů:

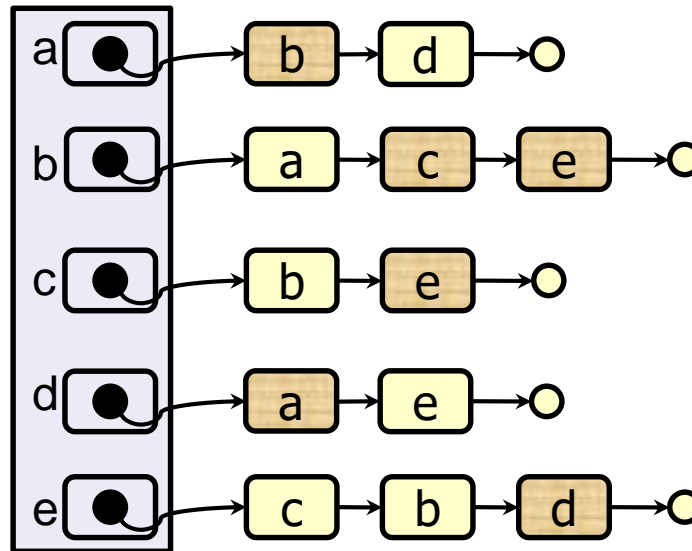

$G_1 = (V, E_1)$

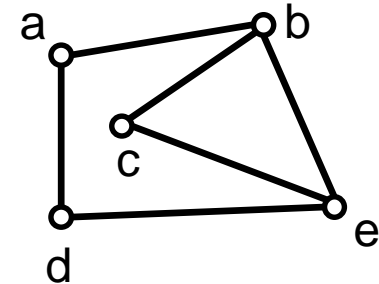

$G_2 = (V, E_2)$

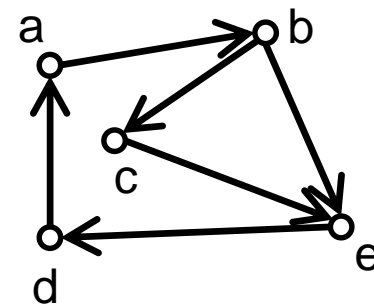

Prostorová složitost

$$\Theta(|V|^2)$$

test existence hrany
v konstantním čase

$$\Theta(|V| + |E|)$$

výhodnější pro řídké grafy

Reprezentace grafu G_2
obsahuje pouze prvky
s pozadím 

Průchod grafem do hloubky (DFS)

Depth-first search

čas otevření / uzavření uzlu

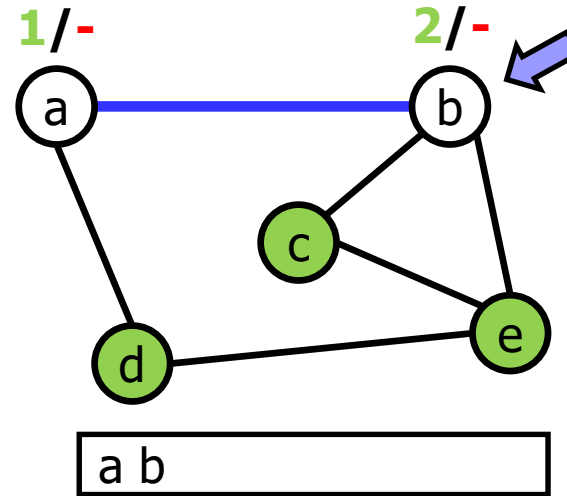
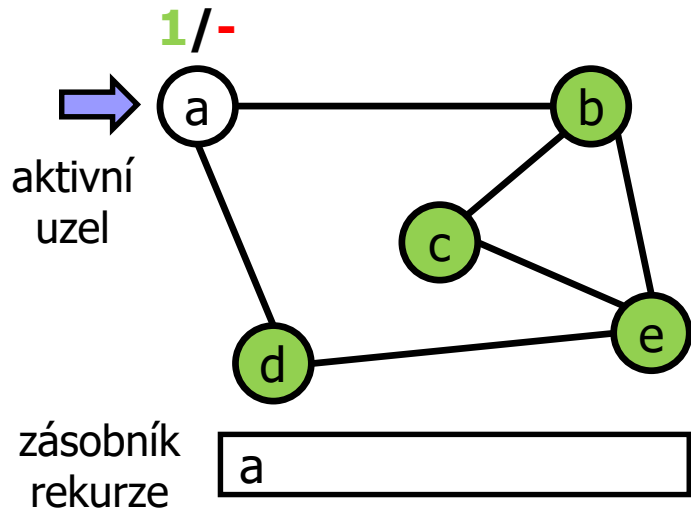

stavy uzlu:



FRESH



OPEN

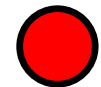

CLOSED

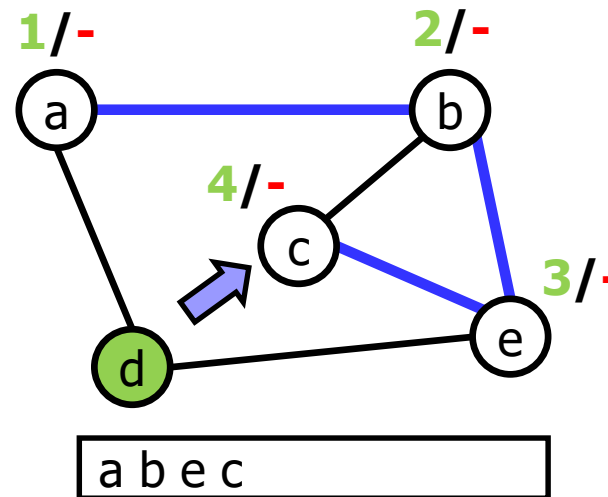
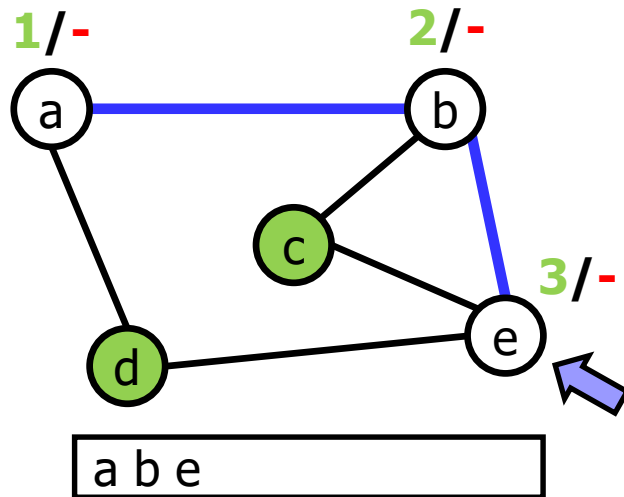

Průchod grafem do hloubky (DFS)

Depth-first search

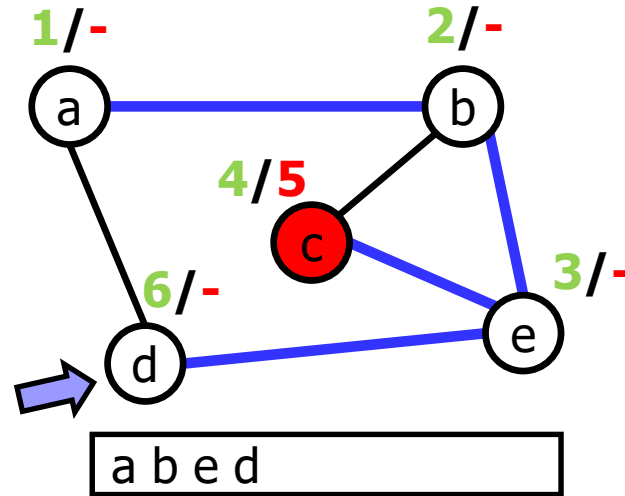
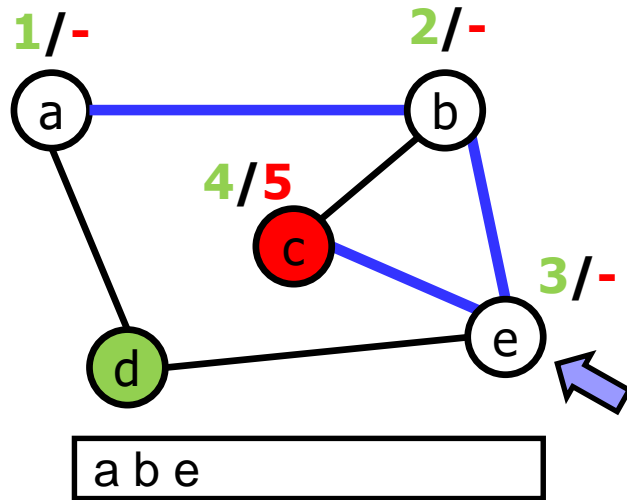

stavy uzlu:



FRESH



OPEN



CLOSED

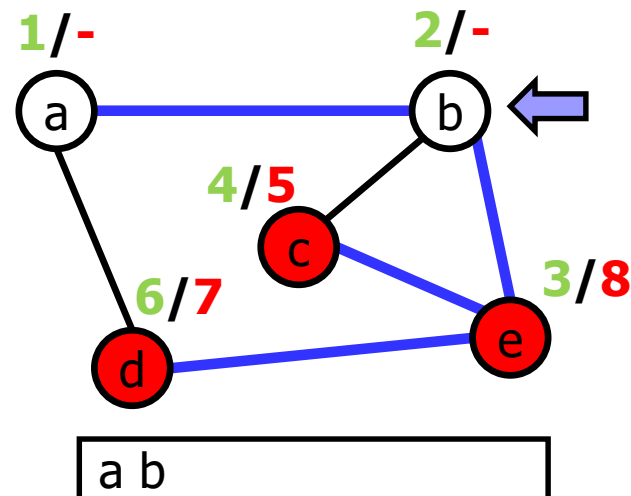
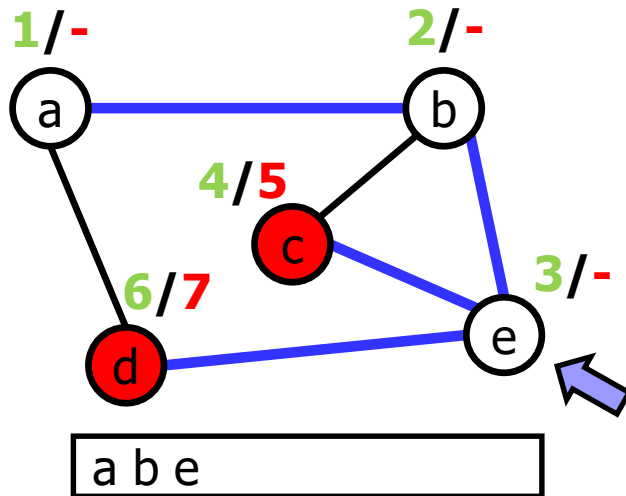

Průchod grafem do hloubky (DFS)

Depth-first search

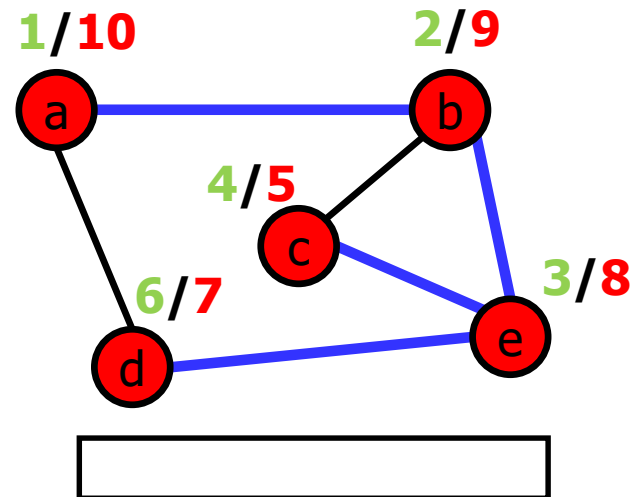
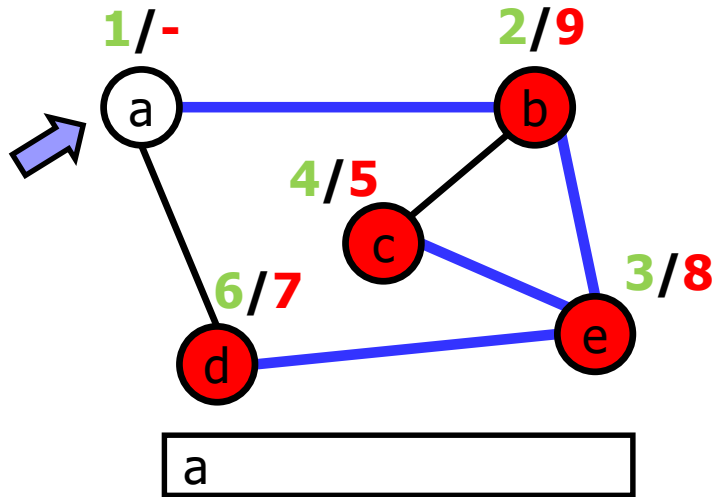

stavy uzlu:



FRESH



OPEN



CLOSED

DFS-strom:

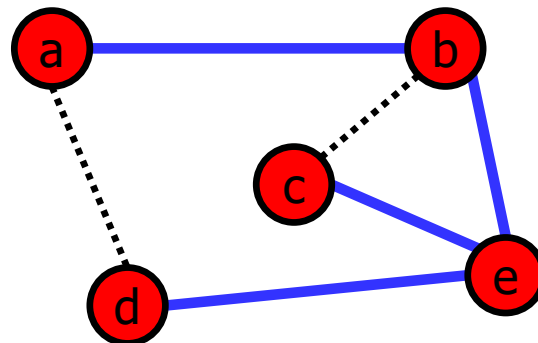

DFS rekurzivně

```
DFS(Node node): // průchod jednou komponentou
  node.visited = true;
  foreach n in node.neighbors do
    if !n.visited then
      DFS(n);
    end;
  end;
```

```
DFS(Node[] nodes): // průchod celým grafem
  foreach node in nodes do
    if !node.visited then
      DFS(node);
    end;
  end;
```

DFS se zásobníkem

```
DFS_iterative(Node node):  
    S = new Stack();  
    S.push(node);  
    while !S.isEmpty() do  
        node = S.pop();  
        if !node.visited then  
            node.visited = true;  
            foreach n in node.neighbors do  
                S.push(n);
```

simuluje rekurzi

- jiné pořadí uzlů než při rekurzi
- uzel může být na zásobník vložen opakovaně

```
DFS_iterative2(Node node):  
    S = new Stack();  
    S.push(new Iterator(node.neighbors));  
    while !S.isEmpty() do  
        if S.peek().hasNext() then  
            n = S.peek().next();  
            if !n.visited then  
                n.visited = true;  
                S.push(new Iterator(node.n));  
            else  
                node = S.pop();
```

Časová složitost DFS

Která z následujících možností nejlépe popisuje časovou složitost DFS pro graf $G = (V, E)$?

- A. $O(|E|)$
- B. $O(|V| + |E|)$
- C. $O(|V|^2)$
- D. $O(|V| \cdot |E|)$

slido



Jakou má DFS časovou složitost pro graf $G=(V,E)$?

ⓘ Start presenting to display the poll results on this slide.

Časová složitost DFS

```
DFS(Node node) :  
    node.visited = true;  
    foreach n in node.neighbors do  
        if !n.visited then  
            DFS(n);  
        end;  
    end;
```

```
DFS(Node[] nodes) :  
    foreach node in nodes do  
        if !node.visited then  
            DFS(node);  
        end;  
    end;
```

$G = (V, E)$ reprezentovaný jako seznam sousedů

$$T(|V|, |E|) = O\left(|V| + \sum_{v \in V} d_v\right) = O(|V| + 2|E|) = O(|V| + |E|)$$

slido



Audience Q&A Session

① Start presenting to display the audience questions on this slide.

Průchod grafem do šířky (BFS)

■ Breadth-first search

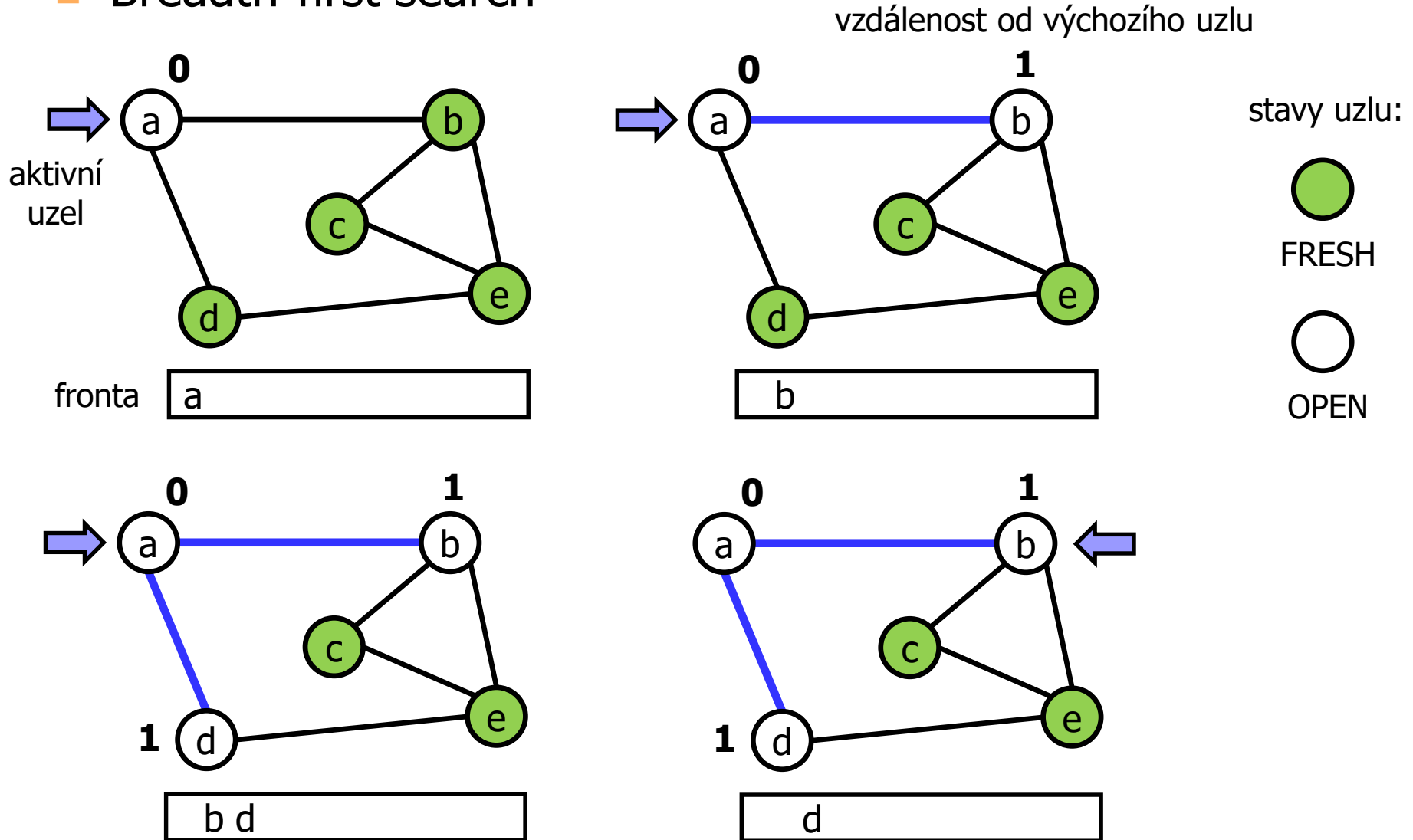

Průchod grafem do šířky (BFS)

■ Breadth-first search

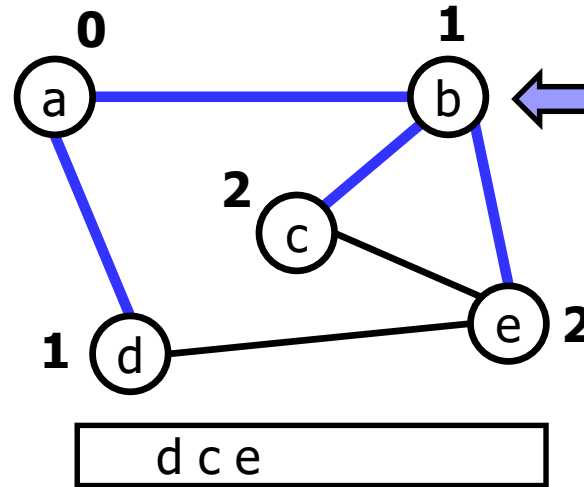
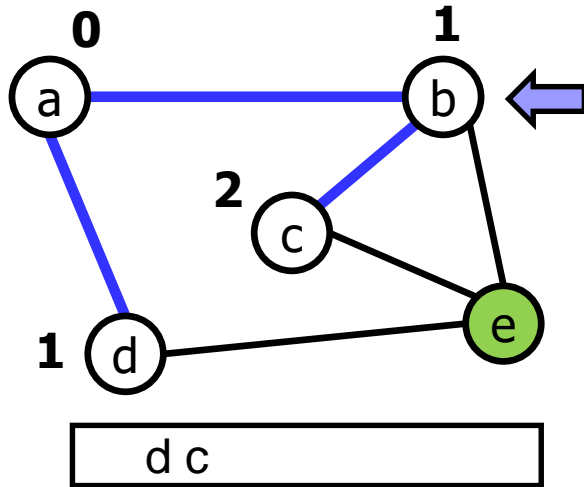

stavy uzlu:



FRESH



OPEN

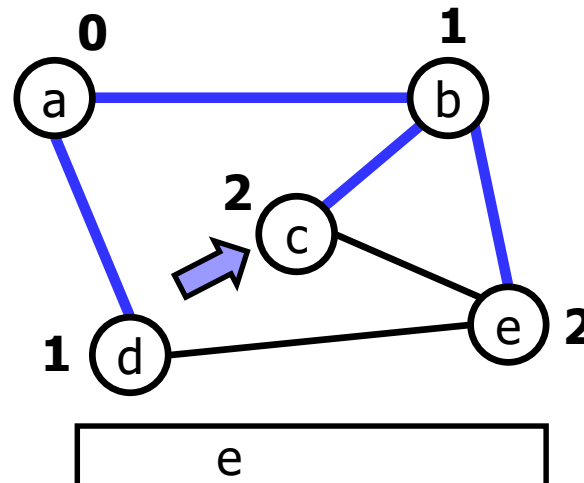
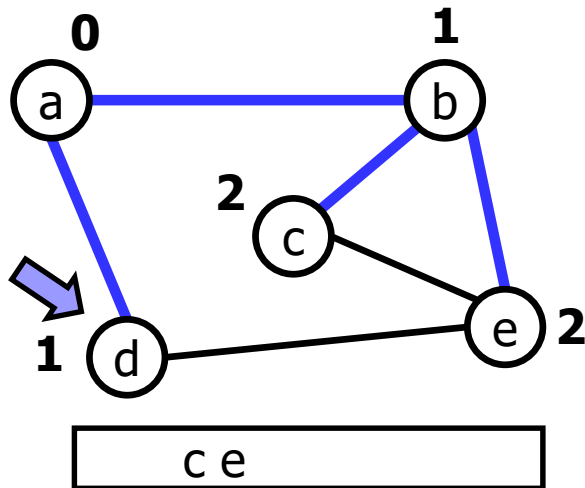

Průchod grafem do šířky (BFS)

■ Breadth-first search

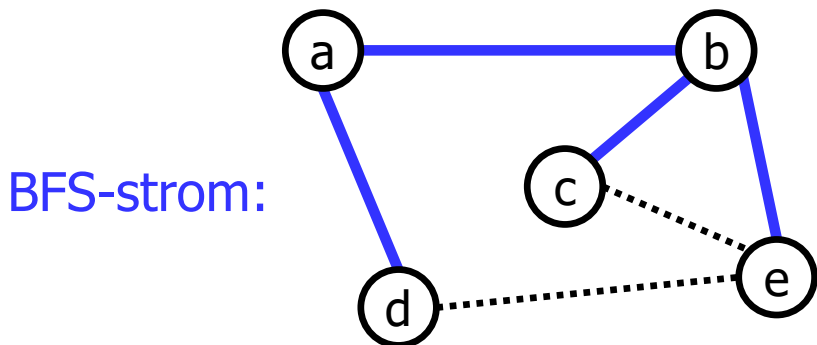
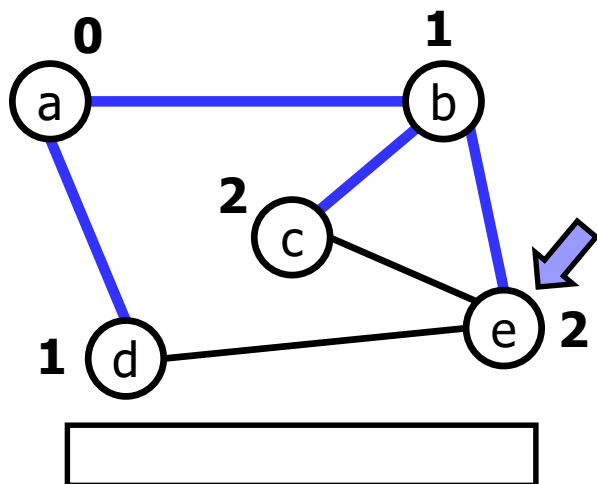

BFS s frontou

```
BFS(Node node): // průchod jednou komponentou
```

```
  Q = new Queue();
```

```
  node.discovered = true;
```

```
  Q.push(node);
```

```
  while !Q.isEmpty() do
```

```
    node = Q.pop();
```

```
    foreach n in node.neighbors do
```

```
      if !n.discovered then
```

```
        n.discovered = true;
```

```
        Q.push(n);
```

```
      end;
```

```
    end;
```

```
  end;
```

```
BFS(Node[] nodes): // průchod celým grafem
```

```
  foreach node in nodes do
```

```
    if !node.discovered then
```

```
      BFS(node);
```

```
    end;
```

```
  end;
```

časová složitost je

$O(|V| + |E|)$

Aplikace průchodu grafem

1. Detekce komponent souvislosti

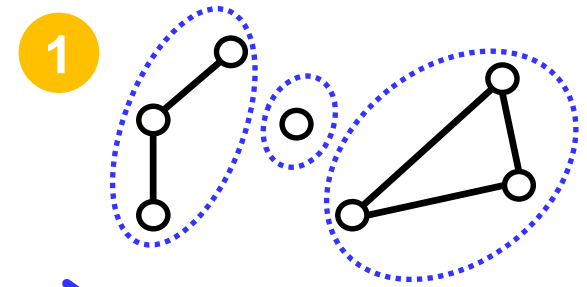

2. Detekce cyklu

(pokud při DFS objevíme uzel ve stavu OPEN => cyklus)

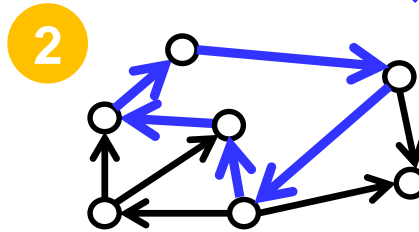

3. Nalezení kostry

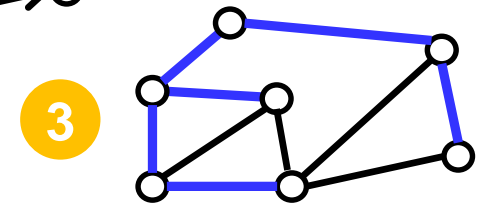

4. Hranově nejkratší cesta (jen BFS)

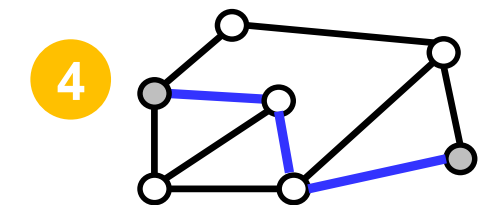

5. Topologické uspořádání (jen DFS)

(uzly uspořádáme sestupně podle časů jejich uzavření)

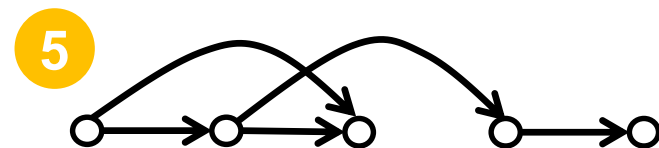

Topologické uspořádání

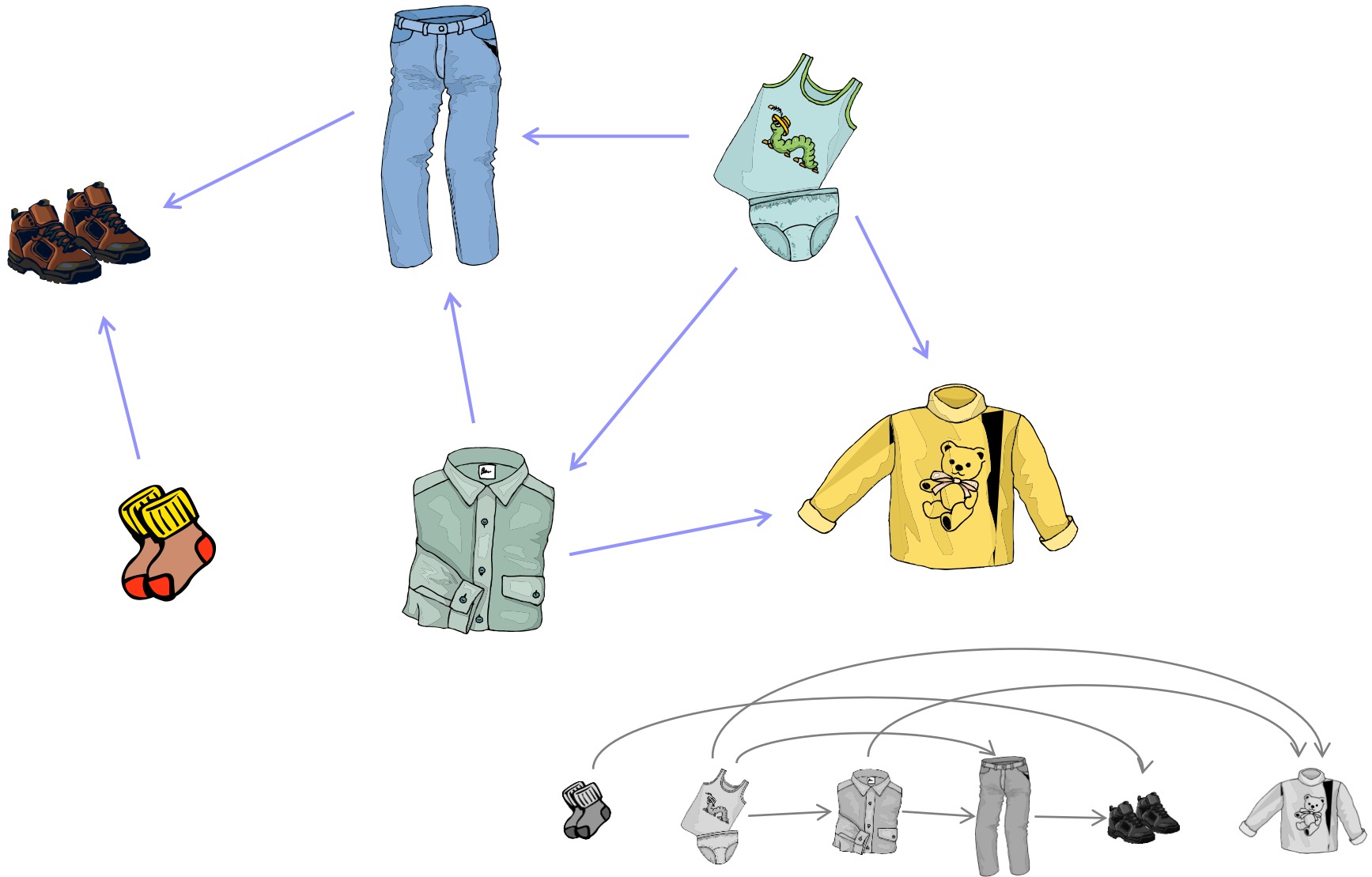

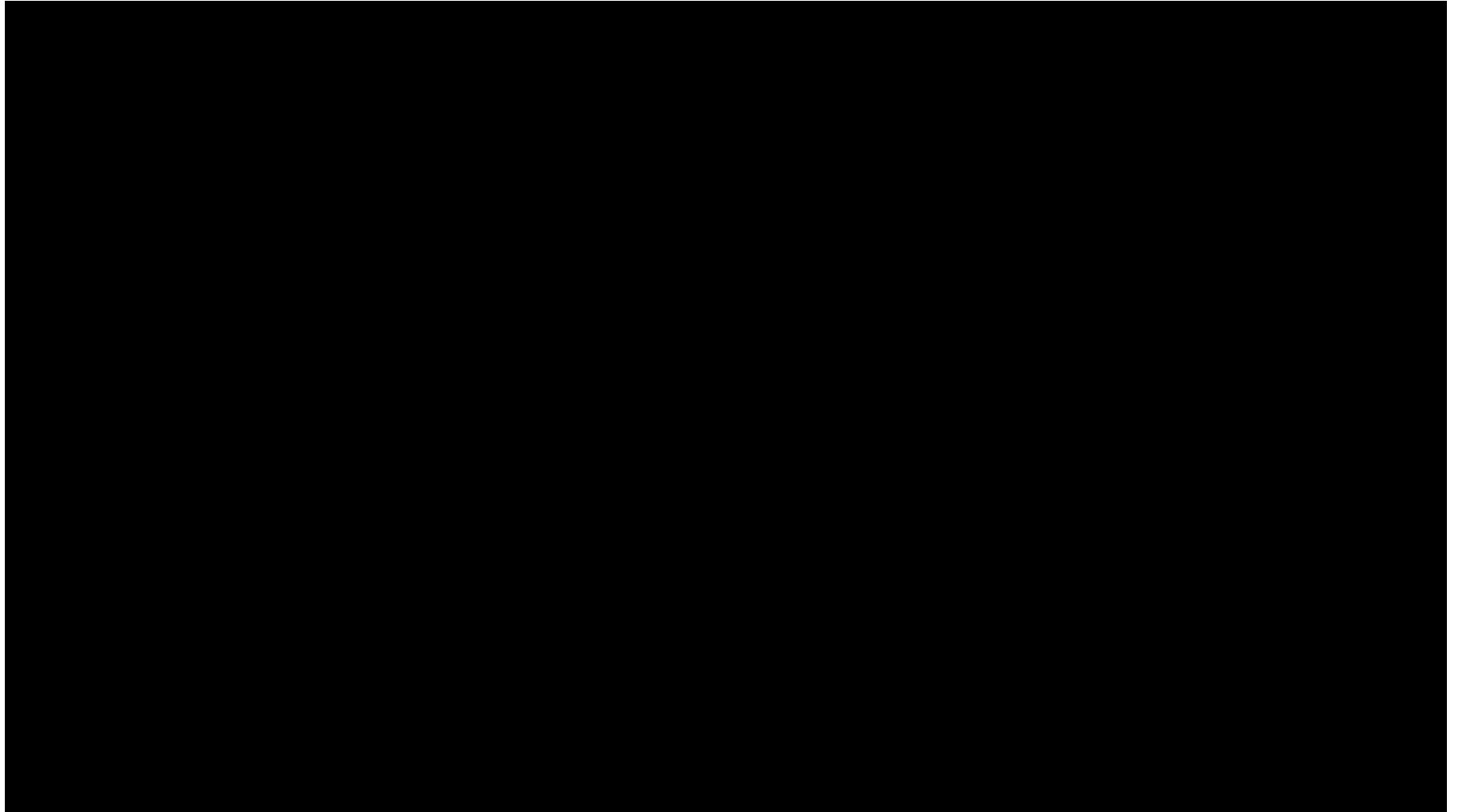

<https://youtu.be/NUgMa5coCoE>

Porovnání DFS a BFS

Mřížka $N \times N$, uspořádání susedů: $\downarrow \rightarrow \uparrow \leftarrow$

DFS (rekurzivně)

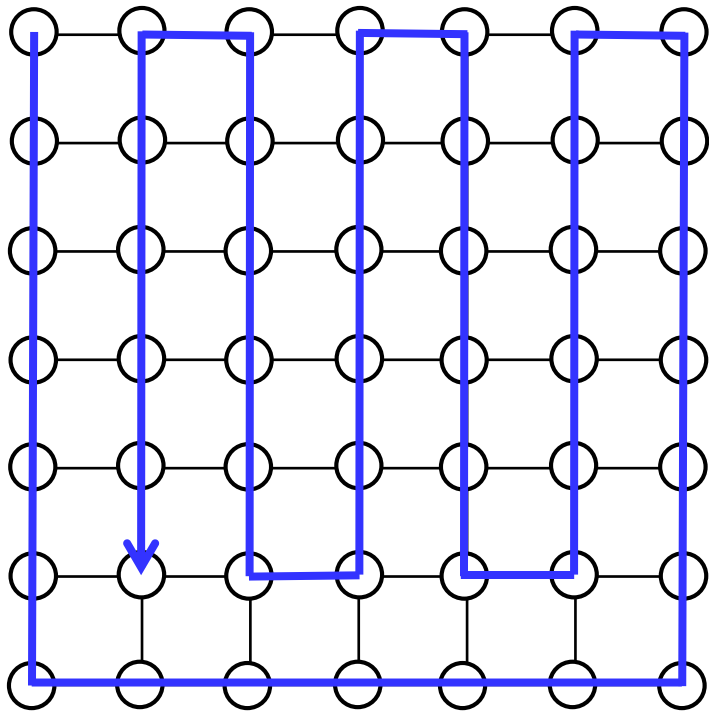

BFS

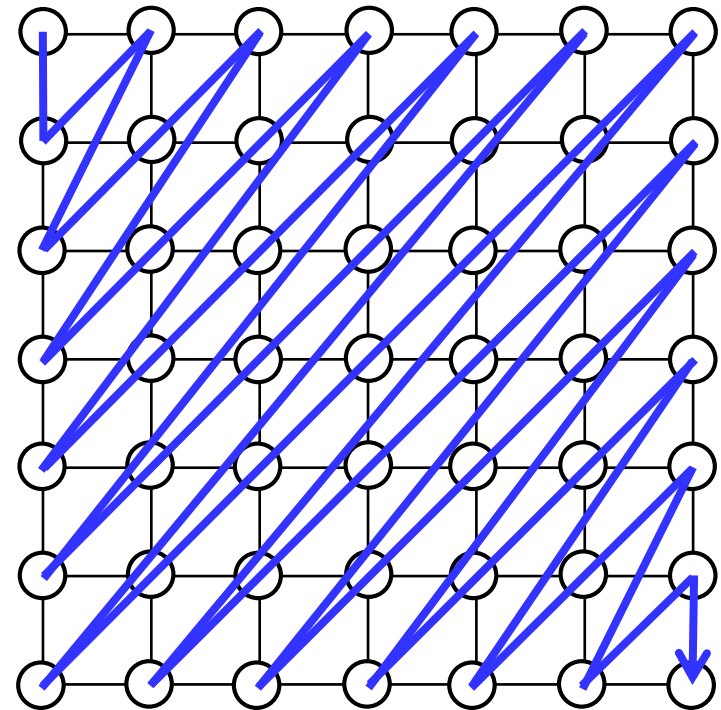

Potřebná velikost zásobníku / fronty:

$$\Theta(N^2)$$

$$\Theta(N)$$

slido



Audience Q&A Session

① Start presenting to display the audience questions on this slide.

Čtvrtá domácí úloha

- Záchrané robotické vozítko se pohybuje po čtvercové mřížce (ne diagonálně).
- Má se přemístit po nejkratší trase ze sektoru S do dektoru T.
- Může projet maximálně F nebezpečných sektorů (hoří v nich).

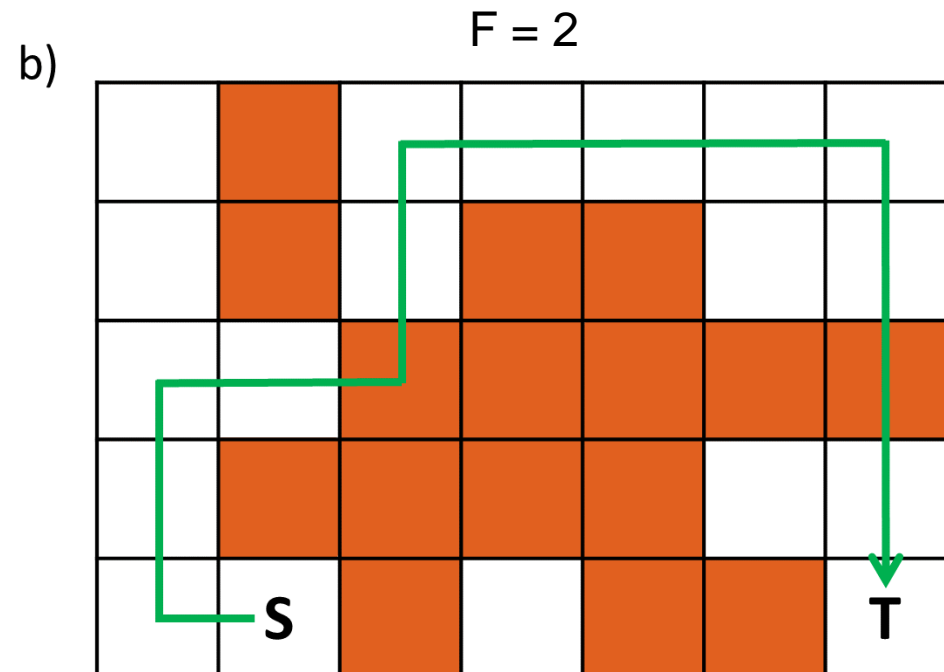
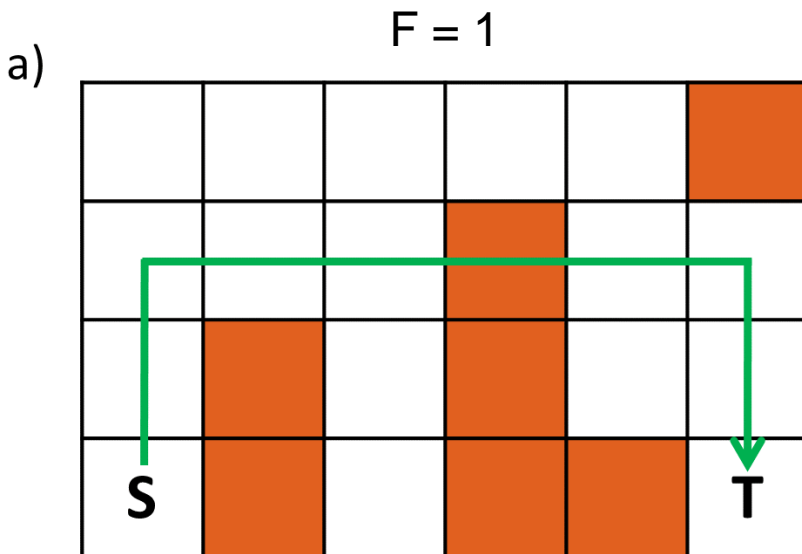

slido



Audience Q&A Session

① Start presenting to display the audience questions on this slide.