

INTEGRATED UTILITIES



IMPROVED PART ACCESS



PATENTED ARM DESIGN

TOP REASONS TO BUY

- Fastest robot in its class due to cutting-edge motors and ARM control
- “Thru-arm” cable design extends cable life; backed by industry’s first two-year torch cable warranty
- Streamlined design improves torch access into tight spaces



MA1400

• ARC WELDING •

Payload: 3 kg

Mounting Options: Ceiling/Wall (MA1400T)

“Master Arc” Welding Robot Fast, Streamlined and Powerful

- Slim, fast six-axis MA1400 “Master Arc” welding robot increases productivity and achieves highest welding performance.
- Reduces welding cycle time due to cutting-edge Sigma-5 AC servo motor control technology and new ARM (Advanced Robot Motion) control.
- 3 kg (6.6-lb) payload; 1,434 mm (56.5") reach; ± 0.08 mm (± 0.003 ") repeatability.
- Proven integrated through-the-arm torch cabling eliminates cable interference, simplifies programming and reduces cable wear.
- Power cable and welding utilities (gas and air hoses) can be routed through robot base.
- Hollow upper arm maintains optimum bend radius of welding torch cable, maximizing weld performance. T-axis can rotate torch ± 200 degrees without cable interference.
- Regardless of torch orientation or part size or shape, prevents bent, pinched or stretched cables, minimizing wire feed problems and optimizing weld performance.
- Floor-mounted model is standard. Ceiling- or wall-mounted versions (MA1400T) available.

- Ideally suited for use in high-density workcells with multiple robots working in close proximity, as well as for applications that require access to parts in tight spots or those with potential interference from fixtures.

DX100 Controller

- Patented multiple robot control supports up to 8 robots/72 axes.
- Windows® CE programming pendant with color touch screen and USB interface.
- DX100 welding full function arc welding software including graphics-based weld file settings.
- Faster processing speeds for smoother interpolation. Quicker I/O response. Accelerated Ethernet communication.
- Extensive I/O suite includes integral PLC and touch screen HMI, 2,048 I/O and graphical ladder editor.
- Supports all major fieldbus networks, including EtherNet/IP, DeviceNet, Profibus-DP and many others.
- Compliant to ANSI/RIA R15.06-1999 and other relevant ISO and CSA safety standards. Optional Category 3 functional safety unit.

MA1400 ROBOT

MA1400 shown.
All dimensions are metric (mm) and for reference only. Please request detail drawings for all design/engineering requirements.

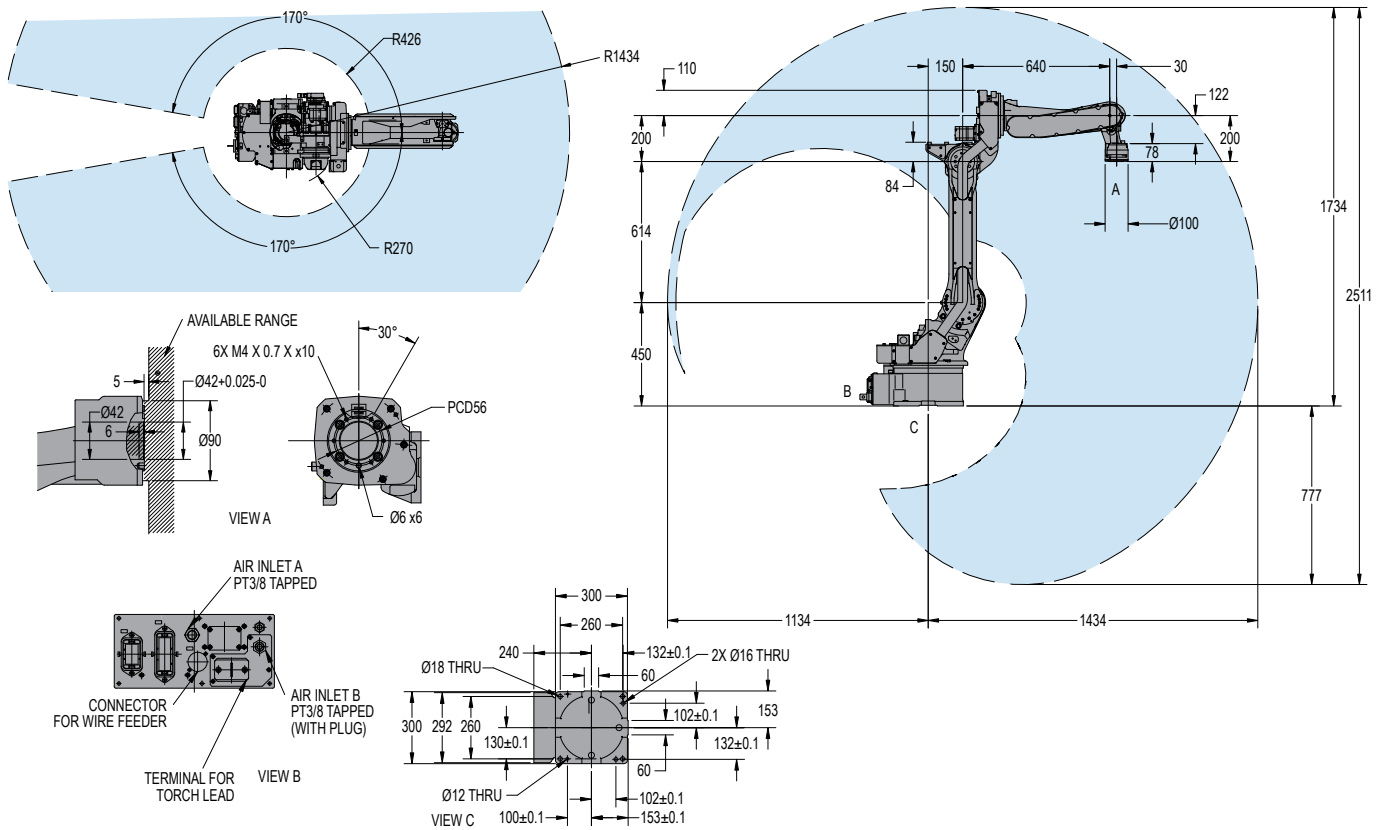

MA1400 SPECIFICATIONS

Structure		Vertical jointed-arm type
Controlled Axes		6
Payload		3 kg (6.6 lbs)
Vertical Reach		2,511 mm (98.9")
Horizontal Reach		1,434 mm (56.5")
Repeatability		±0.08 mm (±0.003")
Maximum Motion Range	S-Axis (Turning/Sweep)	±170°
	L-Axis (Lower Arm)	+155°/-90°
	U-Axis (Upper Arm)	+190°/-175°
	R-Axis (Wrist Roll)	±150°
	B-Axis (Bend/Pitch/Yaw)	+180°/-45°
	T-Axis (Wrist Twist)	±200°
Maximum Speed	S-Axis	200°/s
	L-Axis	200°/s
	U-Axis	220°/s
	R-Axis	410°/s
	B-Axis	410°/s
	T-Axis	610°/s
Approximate Mass		130 kg (286.7 lbs)
Brakes		All axes
Power Consumption		1.5 kVA
Allowable Moment	R-Axis	8.8 N · m
	B-Axis	8.8 N · m
	T-Axis	2.9 N · m
Allowable Moment of Inertia	R-Axis	0.27 kg · m ²
	B-Axis	0.27 kg · m ²
	T-Axis	0.03 kg · m ²

DX100 CONTROLLER SPECIFICATIONS**

Dimensions (mm)	800 (w) x 1,000 (h) x 650 (d) (31.5" x 39.4" x 25.6")
Approximate Mass	250 kg max. (551.3 lbs)
Cooling System	Indirect cooling
Ambient Temperature	During operation: 0° to 45° C (32° to 113° F) During transit and storage: -10° to 60° C (14° to 140° F)
Relative Humidity	90% max. non-condensing
Primary Power Requirements	3-phase, 240/480/575 VAC at 50/60 Hz
Digital I/O	Standard I/O: 40 inputs/40 outputs consisting of 16 system inputs/16 system outputs, 24 user inputs/24 user outputs 32 Transistor Outputs; 8 Relay Outputs Max. I/O (optional): 2,048 inputs and 2,048 outputs
Position Feedback	By absolute encoder
Program Memory	JOB: 200,000 steps, 10,000 instructions CIO Ladder Standard: 15,000 steps Expanded: 20,000 steps
Pendant Dim. (mm)	169 (w) x 314.5 (h) x 50 (d) (6.7" x 12.4" x 2")
Pendant Weight	.998 kg (2.2 lbs)
Interface	One Compact Flash slot; One USB port (1.1)
Pendant Playback Buttons	Teach/Play/Remote Keyswitch selector Servo On, Start, Hold, and Emergency Stop Buttons
Programming Language	INFORM III, menu-driven programming
Maintenance Functions	Displays troubleshooting for alarms, predicts reducer wear
Number of Robots/Axes	Up to 8 robots, 72 axes
Multi Tasking	Up to 16 concurrent jobs, 4 system jobs
Fieldbus	DeviceNet Master/Slave, AB RIO, Profibus, Interbus-S, M-Net, CC Link, EtherNet IP/Slave
Ethernet	10 Base T/100 Base TX
Safety	Dual-channel Emergency Stop Pushbuttons, 3-position Enable Switch, Manual Brake Release Meets ANSI/RIA R15.06-1999, ANSI/RIA/ISO 10218-1-2007 and CSA Z434-03

**See DX100 Controller data sheet (DS-399) for complete specifications

www.motoman.com

YASKAWA

MOTOMAN ROBOTICS

MOTOMAN ROBOTICS
100 AUTOMATION WAY, MIAMISBURG, OHIO 45342
TEL: 937.847.6200 ■ FAX: 937.847.6277

TECHNICAL SPECIFICATIONS SUBJECT TO CHANGE WITHOUT NOTICE
DS-400-C ©2011 YASKAWA AMERICA, INC. JUNE 2011

MOTOMAN IS A REGISTERED TRADEMARK
WINDOWS IS A REGISTERED TRADEMARK OF MICROSOFT
ALL OTHER MARKS ARE THE TRADEMARKS AND
REGISTERED TRADEMARKS OF YASKAWA AMERICA, INC.