

Human-Competitive Results

- **Arthur Samuel:** “The aim of AI is ... to get machines to exhibit behavior, which if done by humans, would be assumed to involve the use of intelligence”.
- John R. Koza, Martin A. Keane, Matthew J. Streeter: **What's AI Done for Me Lately? Genetic Programming's Human-Competitive Results.** IEEE Intelligent Systems 18(3): 25-31 (2003)
http://www.cs.bham.ac.uk/~wbl/biblio/cache/http__www.genetic-programming.com_jkpdf_ieee2003intelligent.pdf
 - The automated problem-solving technique of genetic programming has generated at least 36 human-competitive results (21 of which duplicate previously patented inventions, 6 of which duplicate functionality of inventions patented after 1 January 2000).
 - It also covers two automatically synthesized controllers for which the authors have applied for a patent and includes examples of an automatically synthesized antenna, classifier program, and mathematical algorithm. As computer time becomes ever more inexpensive, researchers will start to routinely use genetic programming to produce useful new designs, generate patentable new inventions, and engineer around existing patents.

Criteria of Human-Competitive Results

- We say that an automatically created result is “*human-competitive*” if it satisfies one or more of the eight criteria below.
 1. The result was patented as an invention in the past, is an improvement over a patented invention, or would qualify today as a patentable new invention.
 2. The result is equal to or better than a result that was accepted as a new scientific result at the time when it was published in a peer-reviewed scientific journal.
 3. The result is equal to or better than a result that was placed into a database or archive of results maintained by an internationally recognized panel of scientific experts.
 4. The result is publishable in its own right as a new scientific result $\frac{3}{4}$ *independent* of the fact that the result was mechanically created.
 5. The result is equal to or better than the most recent human-created solution to a long-standing problem for which there has been a succession of increasingly better human-created solutions.
 6. The result is equal to or better than a result that was considered an achievement in its field at the time it was first discovered.
 7. The result solves a problem of indisputable difficulty in its field.
 8. The result holds its own or wins a regulated competition involving human contestants (in the form of either live human players or human-written computer programs).

Human-Competitive Results

John R. Koza et al.: What's AI Done for Me Lately? Genetic Programming's Human-Competitive Results.

Claimed instance	Basis for claim (criteria number)
1. Creating a better-than-classical quantum algorithm for the Deutsch-Jozsa "early promise" problem ²	2, 5
2. Creating a better-than-classical quantum algorithm for Grover's database search problem ³	2, 5
3. Creating a quantum algorithm for the depth-two AND/OR query problem that is better than any previously published result ^{4,5}	4
4. Creating a quantum algorithm for the depth-one OR query problem that is better than any previously published result ⁵	4
5. Creating a protocol for communicating information through a quantum gate that was previously thought not to permit such communication ⁶	4
6. Creating a novel variant of quantum dense coding ⁶	4
7. Creating soccer-playing program that ranked in the middle of the field of 34 human-written programs in the Robo Cup 1998 competition ⁷	8
8. Creating four different algorithms for the transmembrane segment identification problem for proteins ^{8,9}	2, 5
9. Creating a sorting network for seven items using only 16 steps ⁹	1, 4
10. Rediscovering the Campbell ladder topology for lowpass and highpass filters ⁹	1, 6
11. Rediscovering the Zobel "M-derived half section" and "constant K" filter sections ⁹	1, 6
12. Rediscovering the Cauet (elliptic) topology for filters ⁹	1, 6
13. Automatic decomposition of the problem of synthesizing a crossover filter ⁹	1, 6
14. Rediscovering a recognizable voltage gain stage and a Darlington emitter-follower section of an amplifier and other circuits ⁹	1, 6
15. Synthesizing 60 and 96 decibel amplifiers ⁹	1, 6
16. Synthesizing analog computational circuits for squaring, cubing, square root, cube root, logarithm, and Gaussian functions ⁹	1, 4, 7
17. Synthesizing a real-time analog circuit for time-optimal control of a robot ⁹	7
18. Synthesizing an electronic thermometer ⁹	1, 7
19. Synthesizing a voltage reference circuit ⁹	1, 7
20. Creating a cellular automata rule for the majority classification problem that is better than the Gacs-Kurdyumov-Levin (GKL) rule and all other known rules written by humans ⁹	4, 5
21. Creating motifs that detect the D-E-A-D box family of proteins and the manganese superoxide dismutase family ⁹	3
22. Synthesizing topology for a PID-D2 (proportional, integrative, derivative, and second derivative) controller ¹⁰	1, 6
23. Synthesizing topology for a PID (proportional, integrative, and derivative) controller ¹⁰	1, 6
24. Synthesizing analog circuit equivalent to Philbrick circuit ¹⁰	1, 6
25. Synthesizing NAND circuit ¹⁰	1, 6
26. Simultaneously synthesizing topology, sizing, placement, and routing of analog electrical circuits ¹⁰	7
27. Rediscovering Yagi-Uda antenna ¹⁰	2, 6, 7
28. Creating PID tuning rules that outperform a PID controller using the Ziegler-Nichols and Astrom-Hagglund tuning rules ¹⁰	1, 2, 4, 5, 6, 7
29. Creating three non-PID controllers that outperform PID controllers using the Ziegler-Nichols and Astrom-Hagglund tuning rules ¹⁰	1, 2, 4, 5, 6, 7
30. Rediscovering negative feedback ¹⁰	1, 6
31. Synthesizing a low-voltage balun circuit ¹⁰	1
32. Synthesizing a mixed analog-digital variable capacitor circuit ¹⁰	1
33. Synthesizing a high-current load circuit ¹⁰	1
34. Synthesizing a voltage-current conversion circuit ¹⁰	1
35. Synthesizing a cubic signal generator ¹⁰	1
36. Synthesizing a tunable integrated active filter ¹⁰	1

Six Post-2000 patented analog circuits

- John R. Koza et al.: What's AI Done for Me Lately? Genetic Programming's Human-Competitive Results.

Invention	Date	Inventor	Place	Patent
Low-voltage balun (balance/unbalance) circuit	2001	Sang Gug Lee	Information and Communications University	6,265,908
Mixed analog-digital circuit for variable capacitance	2000	Turgut Sefket Aytur	Lucent Technologies	6,013,958
Voltage-current conversion circuit	2000	Akira Ikeuchi and Naoshi Tokuda	Mitsumi Electric	6,166,529
Low-voltage high-current circuit for testing a voltage source	2001	Timothy Daun-Lindberg and Michael Miller	International Business Machines	6,211,726
Low-voltage cubic function generator	2000	Stefano Cipriani and Anthony A. Takeshian	Conexant Systems	6,160,427
Tunable integrated active filter	2001	Robert Irvine and Bernd Kolb	Infineon Technologies	6,225,859



Project Description

- Genetic programming used to synthesize both
 - the **structure/topology**, and
 - **sizing** (numerical component values)for circuits that duplicate the patented inventions' functionality.
- Method
 - Starts from **a high-level statement of a circuit's desired behavior** and characteristics and only minimal knowledge about analog electrical circuits. Then, **a fitness measure** is created that reflects the invention's performance and characteristics – it **specifies the desired time- or frequency-domain outputs, given various inputs**.
 - Employs a circuit simulator for analyzing candidate circuits, but **does not rely on domain expertise or knowledge concerning the synthesis of circuits**.
 - For each problem, a **test fixture** consisting of appropriate hard-wired components (such as a source resistor or load resistor) connected to the input ports and desired output ports is used.

Low-Voltage Balun Circuit

- A **balun (balance/unbalance) circuit's** purpose is to produce two outputs from a single input
 - each having half of the input's amplitude;
 - one output should be in phase with the input while the other should be 180 degrees out of phase with the input, and both should have the same DC offset.
- The **fitness** measure was based on
 - a frequency sweep analysis designed to measure the magnitude and phase of the circuit's two outputs and
 - a Fourier analysis designed to measure harmonic distortion.

Genetically Evolved Low-Voltage Balun Circuit

- Evolved circuit is roughly a fourfold improvement over the patented circuit in terms of the fitness measure.
 - It is superior both in terms of its frequency response and harmonic distortion.

Test fixture

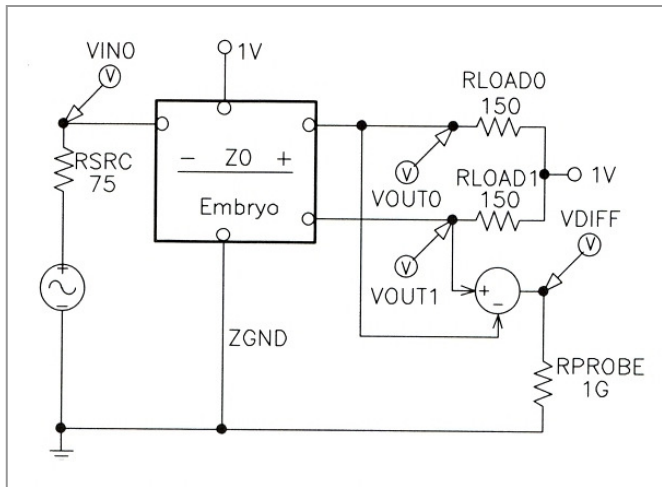

Evolved balun circuit

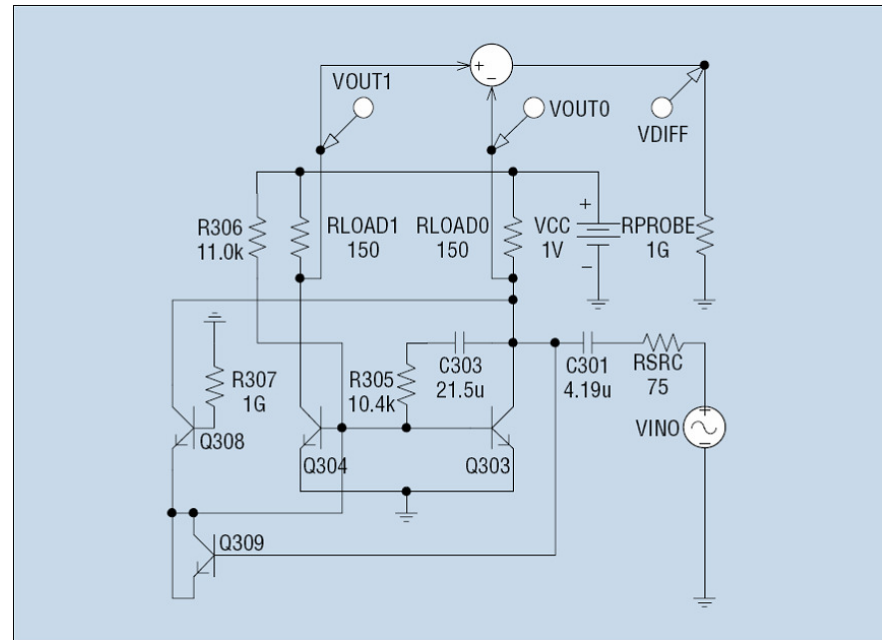

John R. Koza et al.: What's AI Done for Me Lately? Genetic Programming's Human-Competitive Results.

Voltage-Current Conversion Circuit

- **Voltage-current conversion circuit**'s purpose is to take two voltages as input and to produce as output a stable current whose magnitude is proportional to the difference between the voltages.
- **Fitness** measure is based on four time-domain input signals.
- **Genetically evolved circuit**
 - has roughly 62 percent of the average (weighted) error of the patented circuit and
 - outperformed the patented circuit on additional previously unseen test cases.

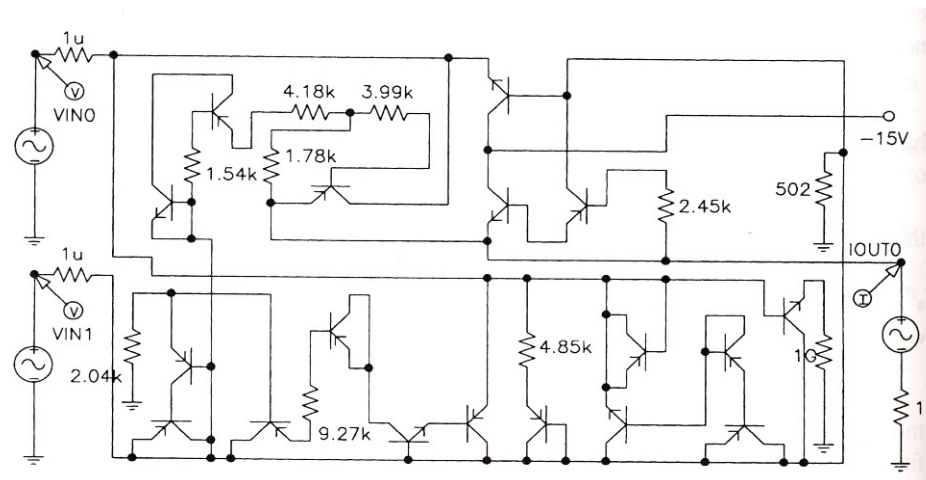

John R. Koza et al.: What's AI Done for Me Lately? Genetic Programming's Human-Competitive Results.

High-Current Load Circuit

- The **genetically evolved circuit shares some features found in the patented solution**
 - a variable, high-current, low-voltage, load circuit for testing a voltage source, comprising ... a plurality of high-current transistors having source-to-drain paths connected in parallel between a pair of terminals and a test load.
 - However, the remaining elements of the genetically evolved circuit bear hardly any resemblance to the patented circuit.

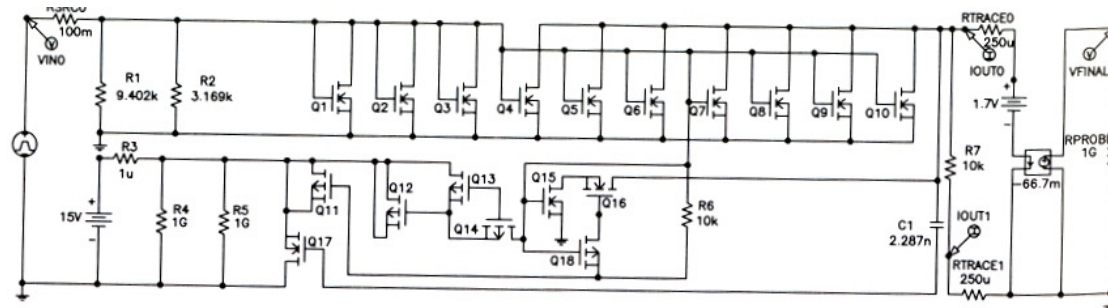

John R. Koza et al.: What's AI Done for Me Lately? Genetic Programming's Human-Competitive Results.

- **GP produced a circuit that duplicates the patented circuit's functionality using a different structure.**

Mixed Analog-Digital Register-Controlled Variable Capacitor

- Mixed analog-digital variable capacitor circuit has a capacitance controlled by the value stored in a digital register.
- **Fitness measure** was based on the error accumulated by 16 combinations of time-domain test signals ranging over all eight possible values of a 3-bit digital register for two different analog input signals.
- **The evolved circuit performs as well as the patented circuit.**

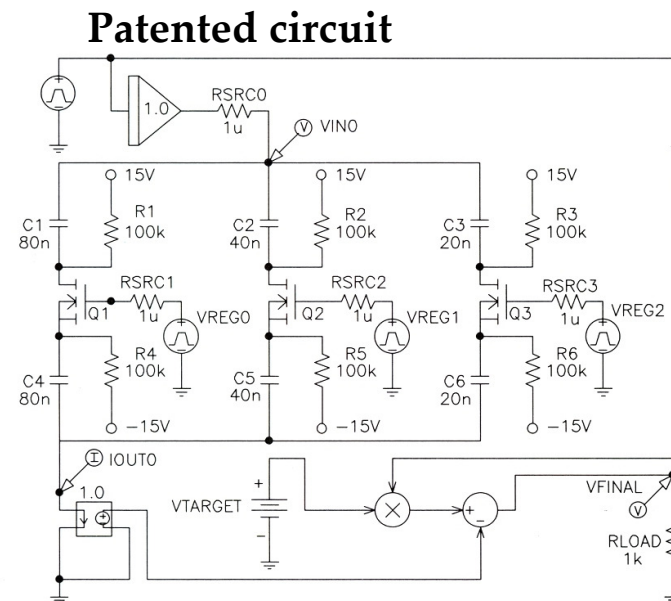
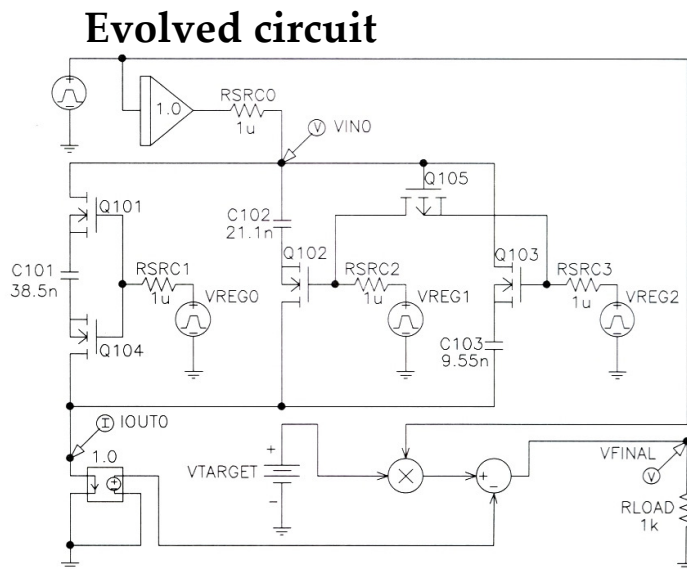

John R. Koza et al.: What's AI Done for Me Lately? Genetic Programming's Human-Competitive Results.

Automatic synthesis of PID controllers

- For the past six decades, most industrial users have relied on the tuning rules that John G. Ziegler and Nathaniel B. Nichols developed in 1942 to select the numerical parameters (for the gain of the controller's proportional, integrative, and derivative blocks and the reference signal's setpoint weighting) for the widely used PID type of controller.
- Karl J. Åström and Tore Hägglund improved upon these rules in 1995.
- **Genetic programming synthesized tuning rules for PID controllers that outperform these existing rules.**

Koza et al. applied for a patent on these new improved tuning rules and the improved non-PID controller described next. If a patent is granted (as expected), it should be the first one for an invention that genetic programming created.

Automatic synthesis of PID controllers cont.

- Genetic programming can automatically create, in a single run, a general (parameterized) solution to a problem in the form of a graphical structure whose edges represent components and where the parameter values of the components are specified by mathematical expressions containing free variables.
- For example, genetic programming recently synthesized both the topology and sizing of an improved general-purpose non-PID controller that outperforms the general-purpose 1995 Astrom-Hagglund PID controller and the widely used Ziegler-Nichols tuning rules.

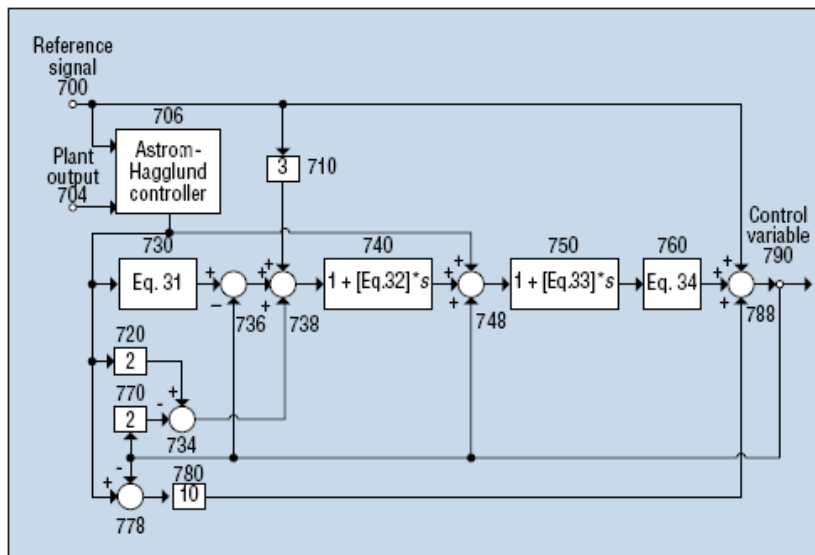

Gain block 730

$$\left| \log T_r ? T_u + \log \frac{\log(|L|^L)}{T_u + 1} \right|$$

Genetically Evolved Sorting Network

- Genetic programming synthesized a 100 percent-correct 16-step sorting network superior (that is, having fewer compare-swap operations) to the one Daniel G. O'Connor and Raymond J. Nelson presented in their 1962 patent (US patent 3,029,413).

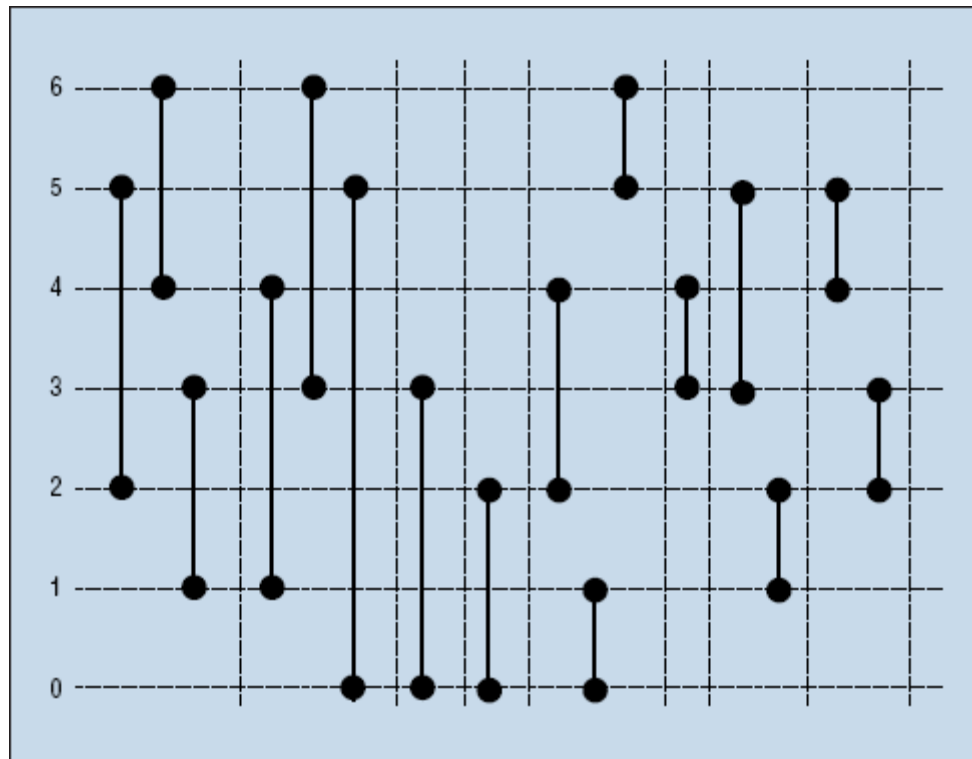

HUMIES

- Annual “**HUMIES**” awards for human-competitive results produced by genetic and evolutionary computation held at the Genetic and Evolutionary Computation Conference (GECCO)
- Entries present **human-competitive results** that have been **produced by any form of genetic and evolutionary computation** (including, but not limited to genetic algorithms, genetic programming, evolution strategies, evolutionary programming, learning classifier systems, grammatical evolution, gene expression programming, differential evolution, etc.) and that have been published in the open literature.
- Human-competitive results awarded in areas:
 - Analog circuit design
 - Quantum circuit design
 - Physics
 - Digital circuits/programs
 - Chemistry
 - Game strategies
 - Image processing
 - Antenna design
 - Classical optimization
 - ...

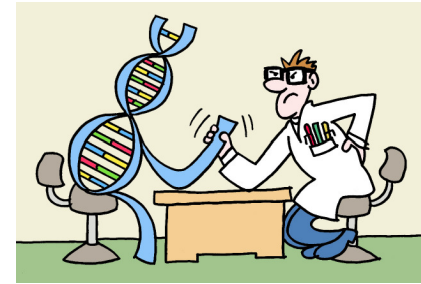



2004 Human-Competitive Awards in Genetic and Evolutionary Computation

- <http://www.genetic-programming.org/gecco2004hc.html>
- **\$1500 – Gold**
 - Jason D. Lohn, Gregory S. Hornby, Derek S. Linden: **An Evolved Antenna for Deployment on NASA's Space Technology 5 Mission**
 - Lee Spector: **Automatic Quantum Computer Programming: A Genetic Programming Approach**
- **\$500 – Silver**
 - Alex Fukunaga: **Evolving Local Search Heuristics for SAT Using GP**
 - Hod Lipson: **How to Draw a Straight Line Using a GP: Benchmarking Evolutionary Design Against 19th Century Kinematic Synthesis**
 - Bijan Khosraviani, Raymond E. Levitt, John R. Koza: **Organization Design Optimization Using Genetic Programming**
- **\$500 – Bronze**
 - Adrian Stoica, Ricardo Zebulum, Didier Keymeulen, Michael Ian Ferguson, Vu Duong, Xin Guo: **Taking evolutionary circuit design from experimentation to implementation: some useful techniques and a silicon demonstration**

The winner of Humies 2004

- Three nanosats (20in diameter).
- Measure effect of solar activity on the Earth's magnetosphere.

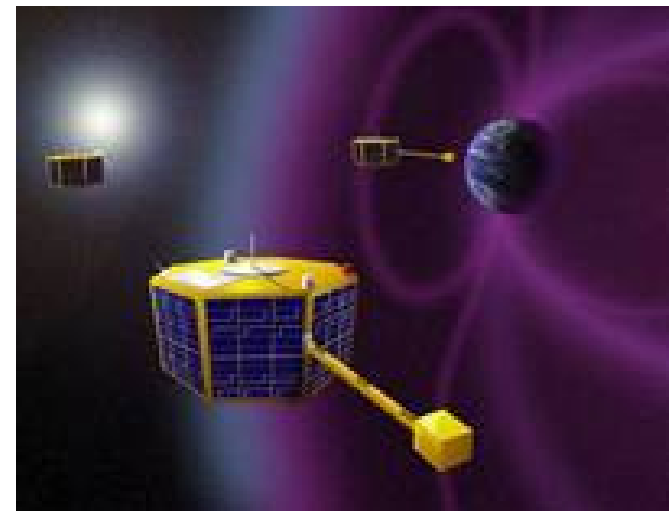
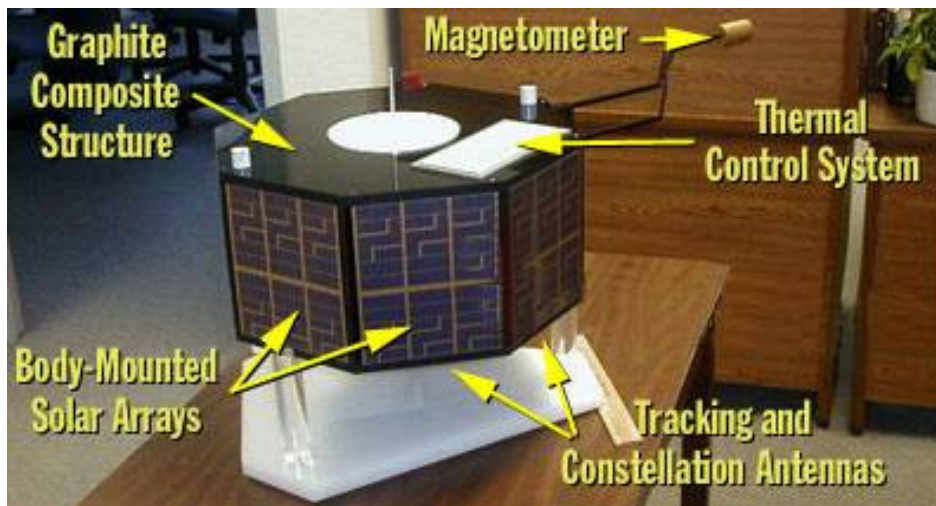

© Jason D. Lohn, Gregory S. Hornby, Derek S. Linden: Human-Competitive Results: Evolved Antennas for Deployment on NASA's Space Technology 5 Mission

Evolved Antennas for Deployment on NASA's Space Technology 5 Mission

Original ST5 Antenna Requirements

- Transmit: 8470 MHz
- Receive: 7209.125 MHz
- Gain:
 - >= 0dBic, 40 to 80 degrees
 - >= 2dBic, 80 degrees
 - >= 4dBic, 90 degrees
- 50 Ohm impedance
- Voltage Standing Wave Ratio (VSWR):
 - < 1.2 at Transmit Freq
 - < 1.5 at Receive Freq
- Fit inside a 6" cylinder

ST5 Quadrifilar Helical Antenna

- designed by a team of human designers



© Jason D. Lohn, Gregory S. Hornby, Derek S. Linden: Human-Competitive Results: Evolved Antennas for Deployment on NASA's ST5 Mission

Evolved Antenna for Space Technology 5 mission

■ Branching EA: Antenna Genotype

- Genotype is a tree-structured encoding that specifies the construction of a wire form
- Genotype specifies design of 1 arm in 3-space:

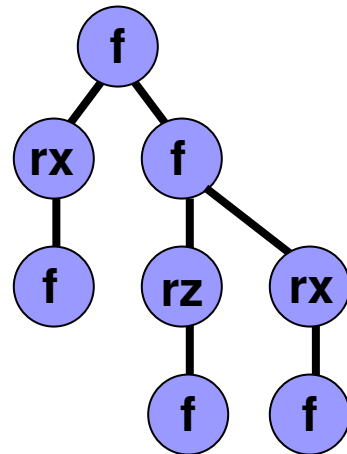

- Branching in genotype results in branching in wire form

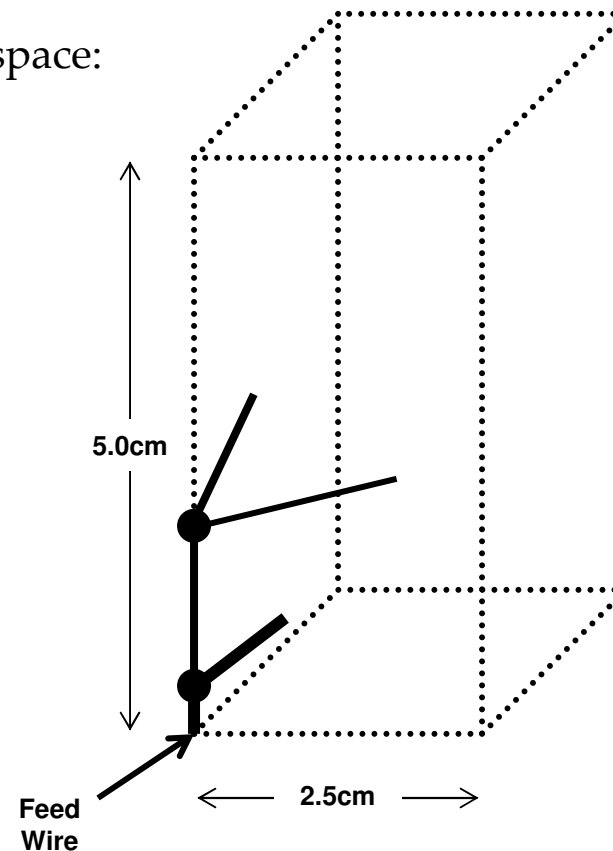

© Jason D. Lohn, Gregory S. Hornby, Derek S. Linden: Human-Competitive Results: Evolved Antennas for Deployment on NASA's Space Technology 5 Mission

Evolved Antenna for Space Technology 5 mission

■ Branching EA: Antenna Construction Commands

- forward(length radius)
- rotate_x(angle)
- rotate_y(angle)
- rotate_z(angle)

Forward() command can have 0,1,2, or 3 children.

Rotate_x/y/z() commands have exactly 1 child (always non-terminal).

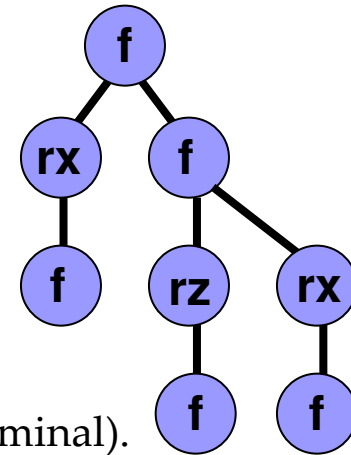

■ Fitness function (to be minimized):

$$F = \text{VSWR_Score} * \text{Gain_Score} * \text{Penalty_Score}$$

Evolved Antenna for Space Technology 5 mission

■ 1st Set of Genetically Evolved Antennas

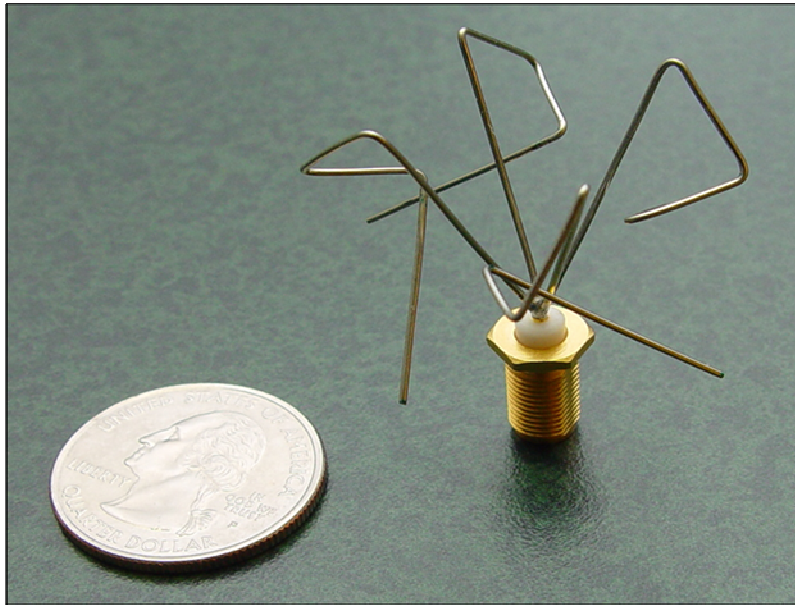

Non-branching:
ST5-4W-03

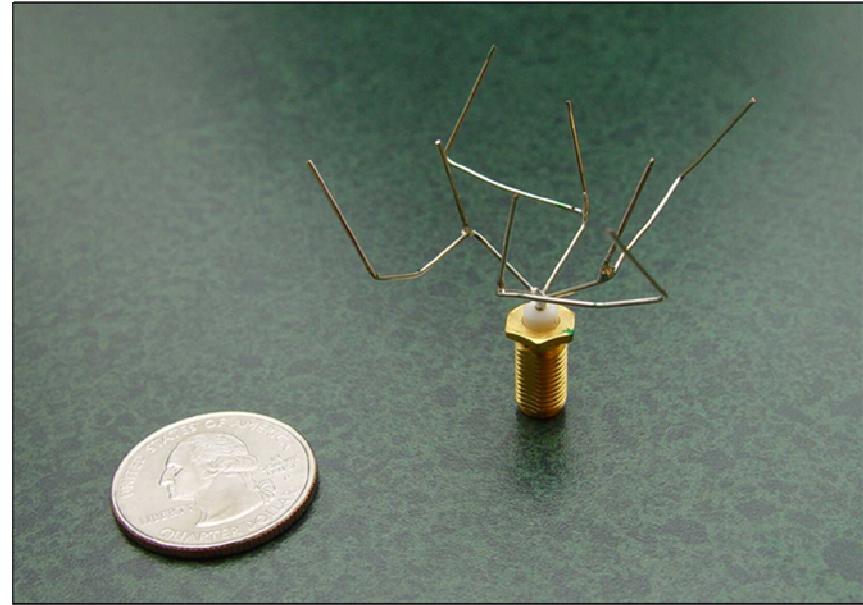

Branching:
ST5-3-10

© Jason D. Lohn, Gregory S. Hornby, Derek S. Linden: Human-Competitive Results: Evolved Antennas for Deployment on NASA's Space Technology 5 Mission

Evolved Antenna for Space Technology 5 mission

- 2nd Set of genetically evolved antennas for new mission requirements

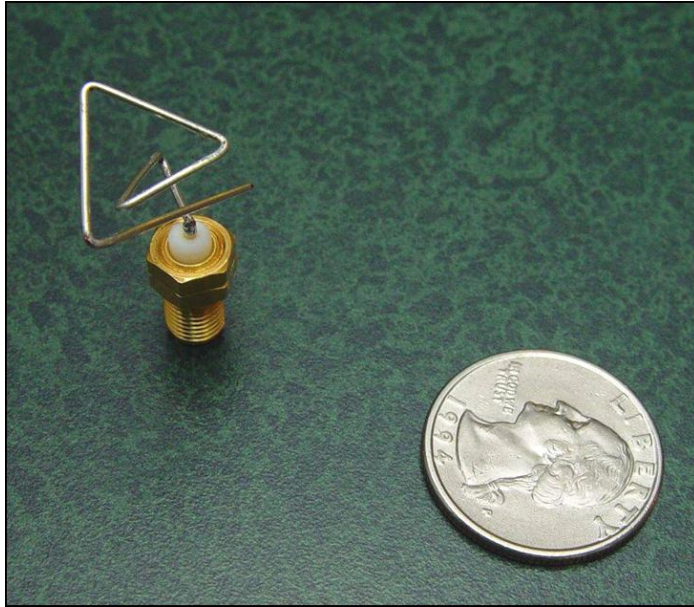

EA 1 – Vector of Parameters

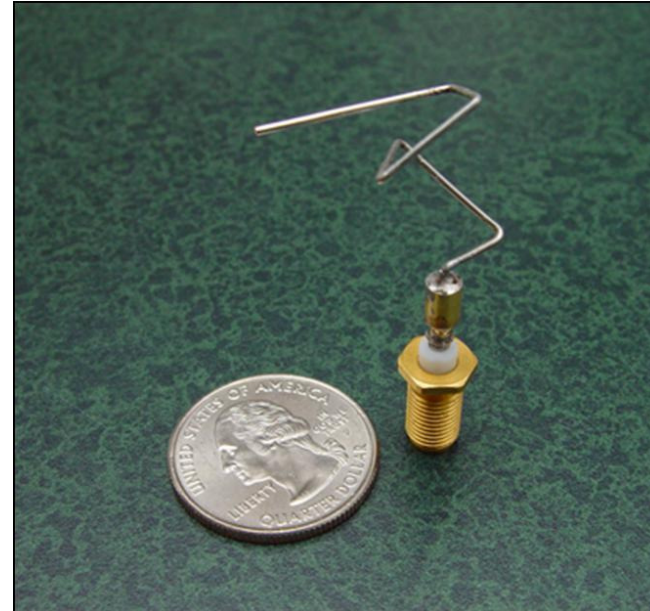

EA 2 – Constructive Process

© Jason D. Lohn, Gregory S. Hornby, Derek S. Linden: Human-Competitive Results: Evolved Antennas for Deployment on NASA's Space Technology 5 Mission



Evolved Antenna for Space Technology 5 mission

- **Conclusion**
 - Meets mission requirements.
 - Better than conventional design.
 - Successfully passed space qualification.
 - **First Evolved Hardware in Space when mission launched in 2005.**
- **Direct competition:** The antenna designed by the contracting team of human designers for the Space Technology 5 mission - which won the bid against several competing organizations to supply the antenna - did not meet the mission requirements while the evolved antennas did meet these requirements.
- **Evolutionary design:**
 - Fast design cycles save time/money (**4 weeks from start-to-first-hardware**).
 - Fast design cycles allow iterative “what-if”.
 - Can rapidly respond to changing requirements.
 - Can produce new types of designs.
 - May be able to produce designs of previously unachievable performance.

How to Draw a Straight Line Using a GP

- Hod Lipson: How to Draw a Straight Line Using a GP: Benchmarking Evolutionary Design Against 19th Century Kinematic Synthesis
 - This entry presents the application of genetic programming to the synthesis of compound 2D kinematic mechanisms, and benchmarks the results against one of the classical kinematic challenges of 19th century mechanical design.
- Test Case: **The Straight Line Problem**
 - The straight-line problem seeks a kinematic mechanism that traces a straight line without reference to an existing straight line.
 - For example, a circle is easy, a line is a challenge!

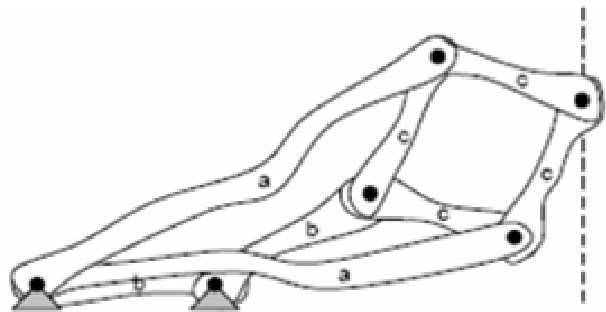

line

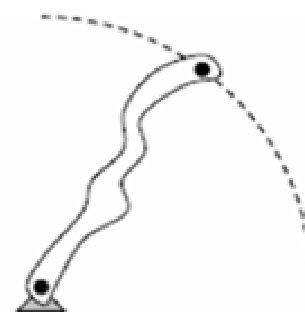

circle

How to Draw a Straight Line Using a GP

Some key straight-line mechanisms

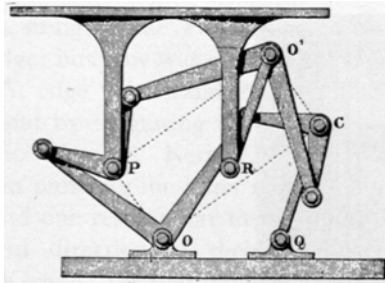

Silverster-Kempe's
(1877)

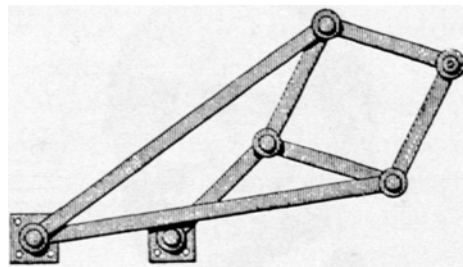

Peaucellier
(1873)

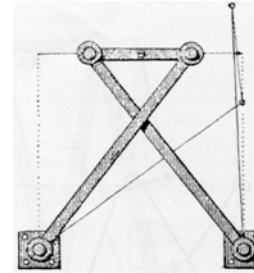

Chebyshev
(1867)

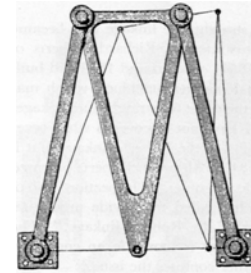

Robert
(1841)

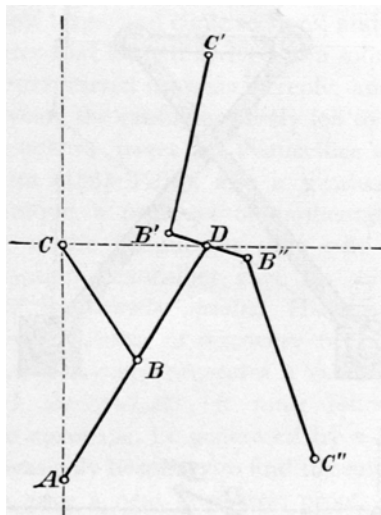

Chebyshev
(1867)

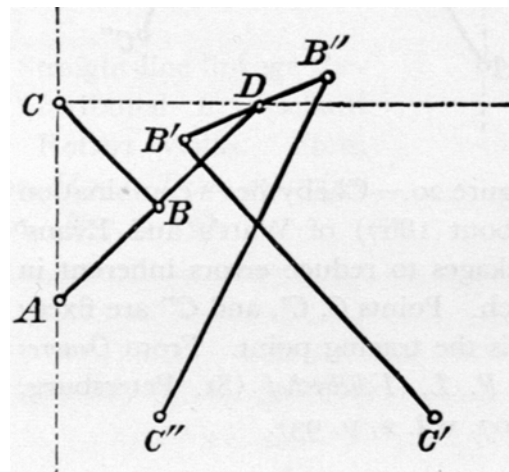

Chebyshev-Evans
(1907)

See
<http://kmoddl.library.cornell.edu>

How to Draw a Straight Line Using a GP

Top down encoding of a mechanism

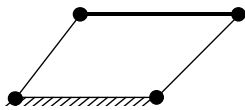

Start with Embryo with desired # of DoF, e.g. a four-bar mechanism (1 DoF)

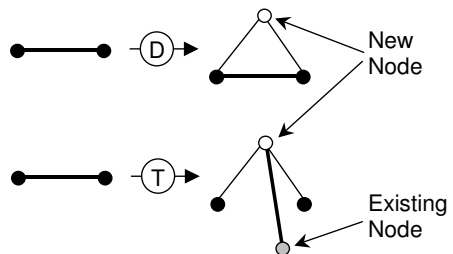

Two variation operators maintain DoF

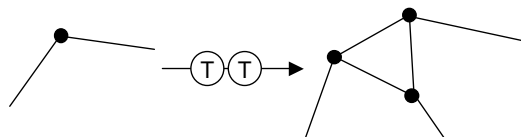

E.g. Transform dyad into triad

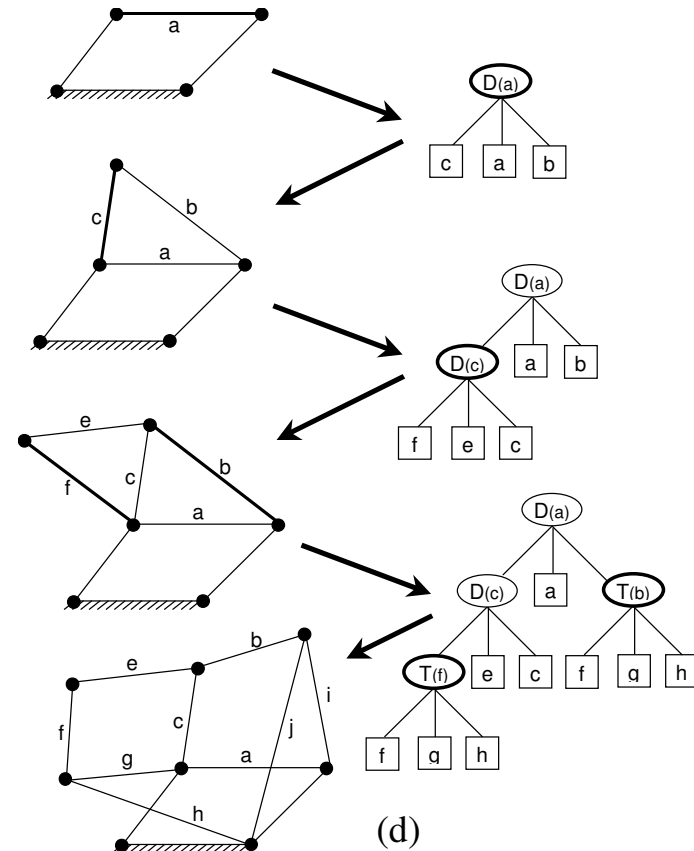

Example: A tree that constructs this 1-DoF compound mechanism

How to Draw a Straight Line Using a GP

- **Comparison of mechanisms** can be difficult
 - Equivalent mechanisms may appear very different
 - Masked by excess and redundant topology
- **Two transformations** allow moving in “neutral pathways” of mechanisms
 - Rigid diagonal swap
 - Redundant dyad removal/addition

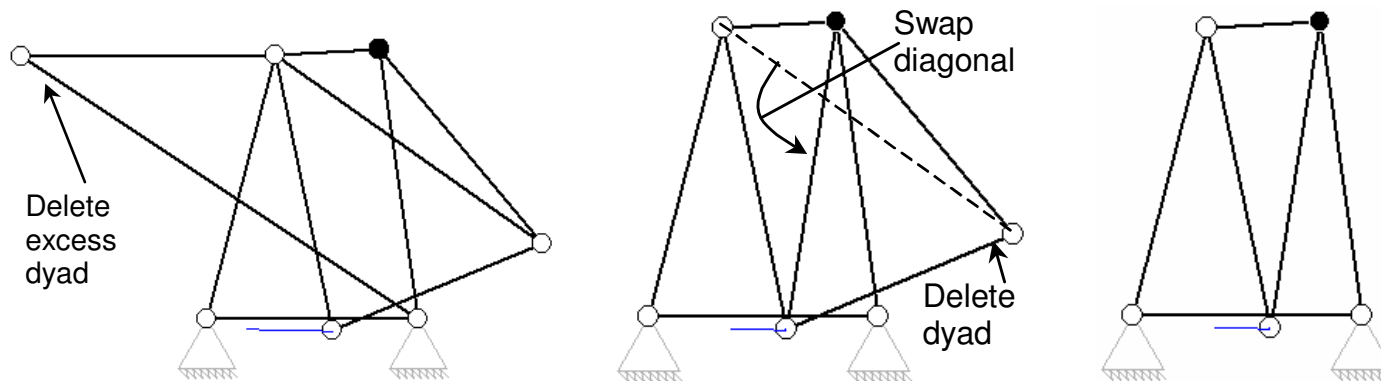

How to Draw a Straight Line Using a GP

- Used **GP with Top-down tree encoding and 2-bar or 4-bar embryo**
 - Population size: 100
 - Crossover 90%
 - Mutation 10% (Node positions, Operator types)
- Selection: **Stochastic Universal Sampling**
- **Evaluation of an evolved straight-line mechanism**
 - The mechanism is actuated at an arbitrary handle and the aspect ratios of bounding boxes of node trajectories are measured.
 - One node of the evolved machine on the left traces a curve that is linear to 1:5300 accuracy.
 - The evolved mechanism on the right traces a curve that is linear to 1:28340 accuracy

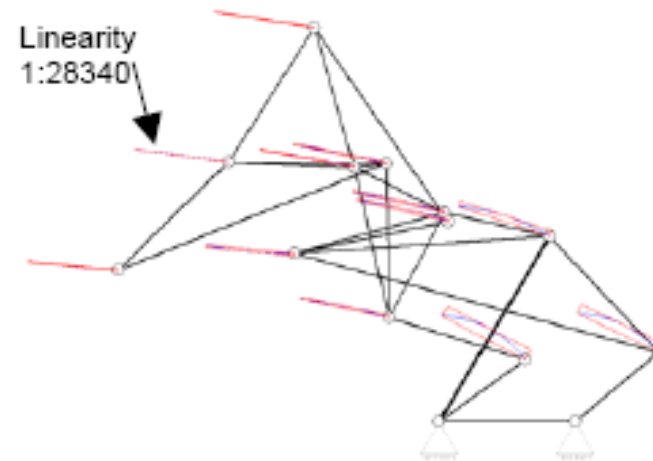
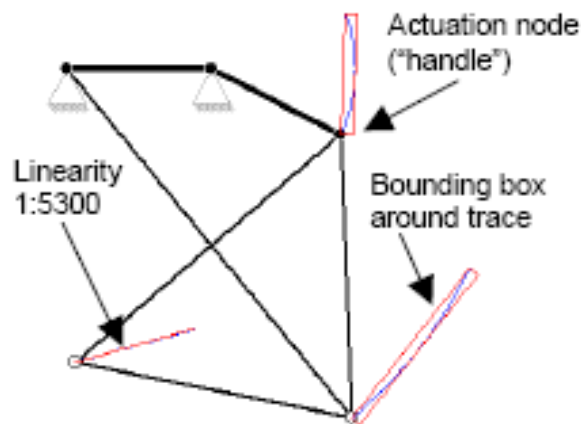

How to Draw a Straight Line Using a GP

- **A typical run** – each dot represents an evaluated individual

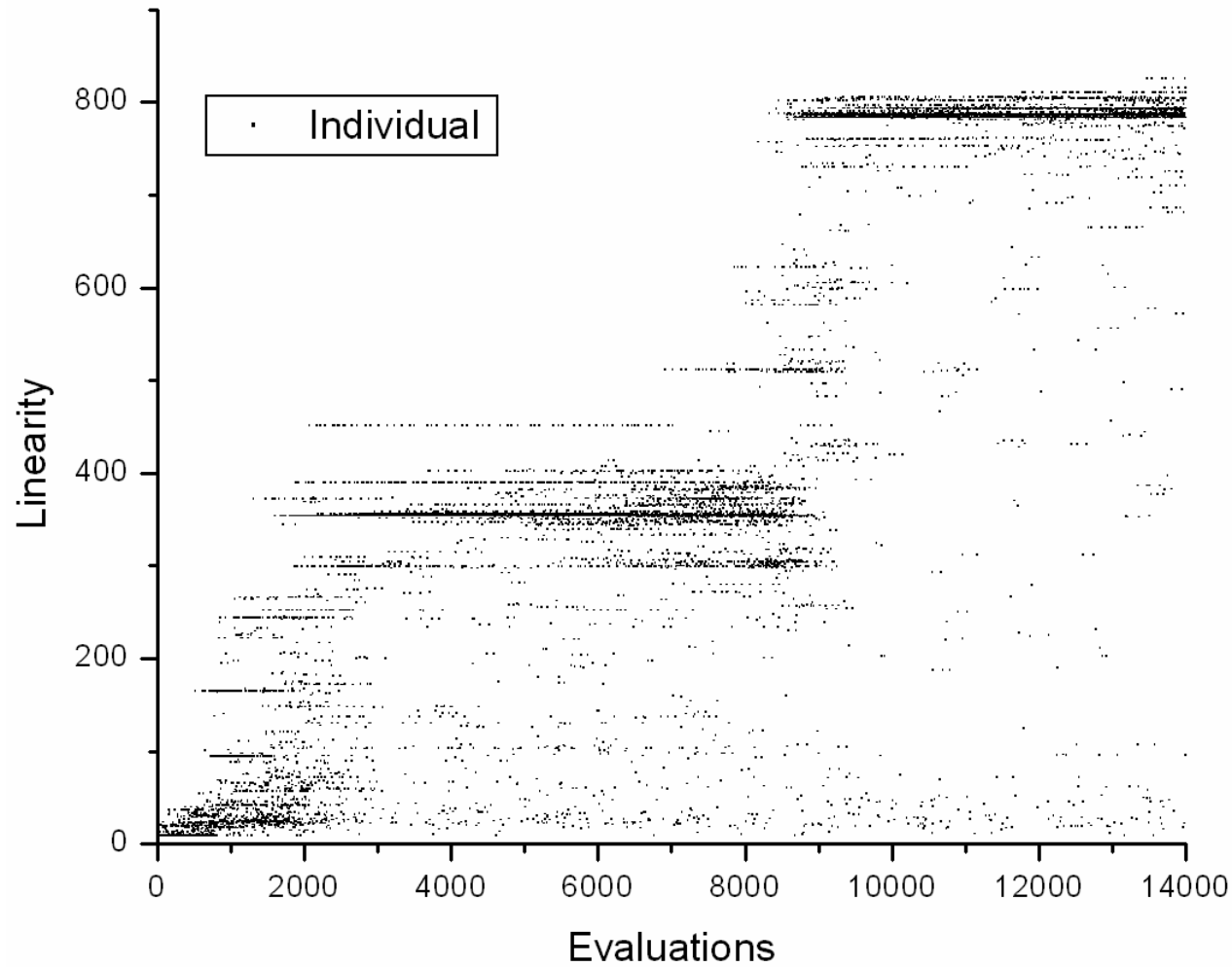

Some results

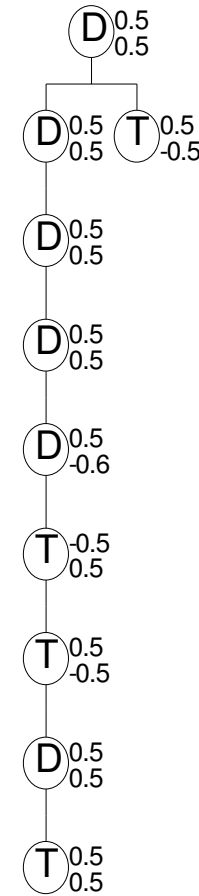
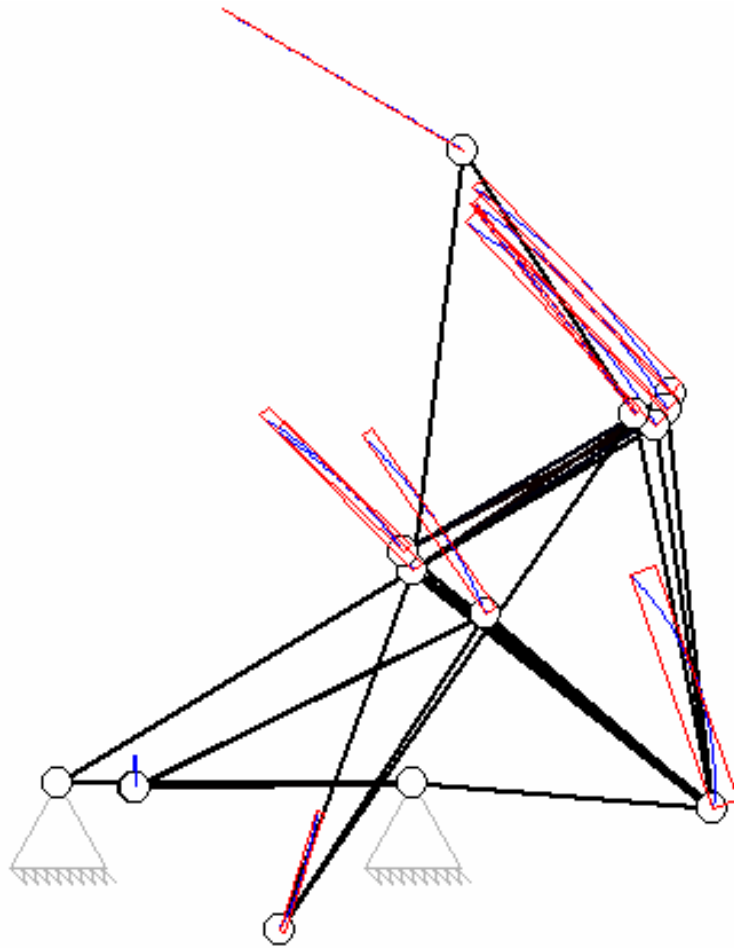

Linearity 1:4979

Some results

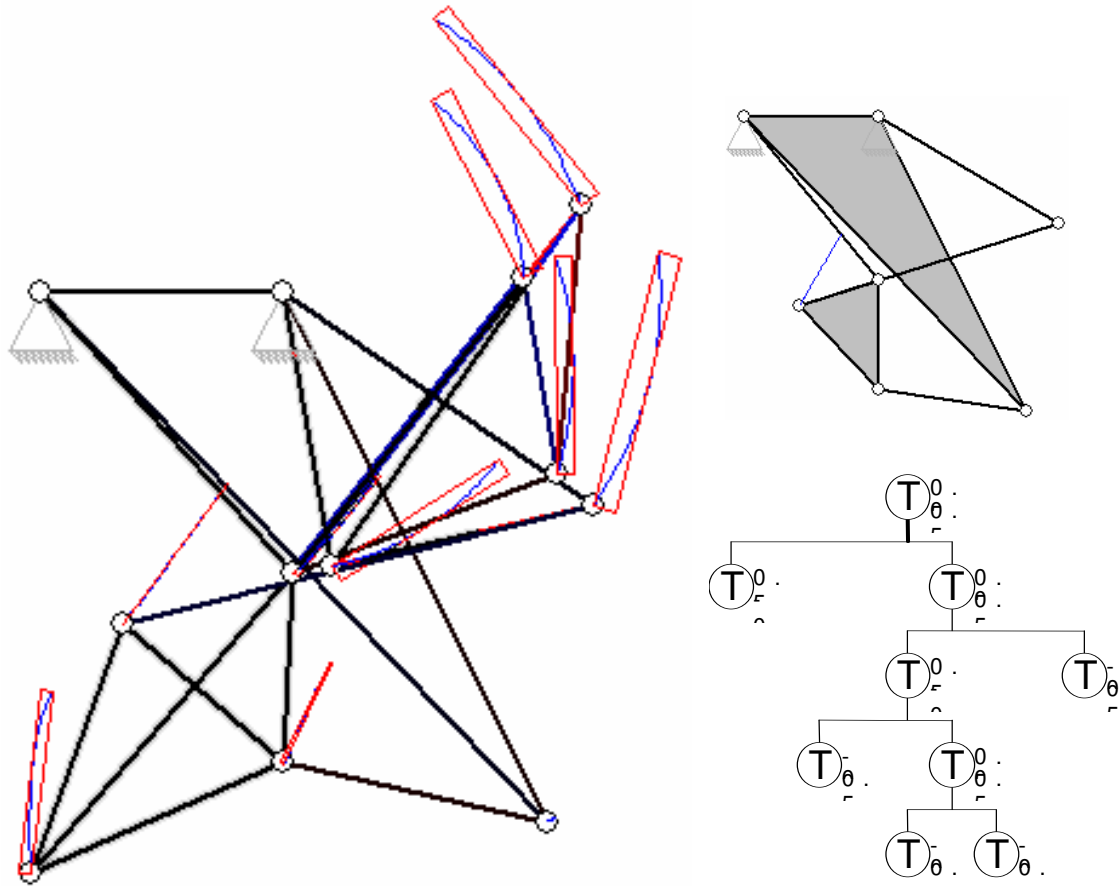

Linearity 1:12819

Some results

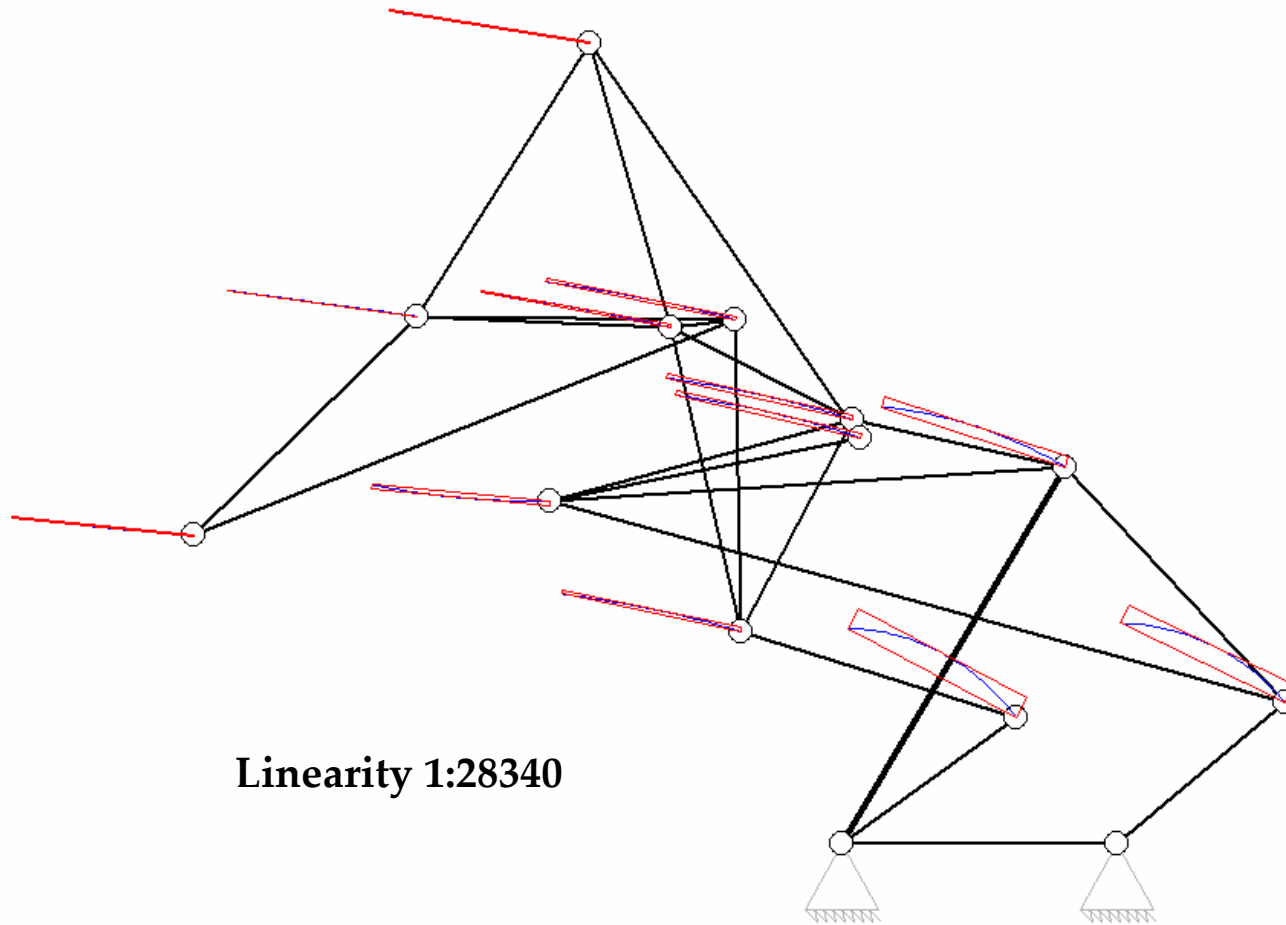



2005 Human-Competitive Awards in Genetic and Evolutionary Computation

- <http://www.genetic-programming.org/hc2005/cfe2005.html>
- **\$2500 – Gold**
 - Randy Bartels et al.:
 - (1) Learning from Learning Algorithms: Applications to attosecond dynamics of high-harmonic generation,**
 - (2) Shaped-pulse optimization of coherent soft-x-rays.**

Bartels, R. et al.: Learning from Learning Algorithms: Applications to attosecond dynamics of high-harmonic generation. Physical Review A. 70(1):1-5 (2004)
 - Stefan Preble, Hod Lipson, Michal Lipson: **Two-dimensional photonic crystals designed by evolutionary algorithms**
- **\$1000 – Silver**
 - John Koza, Sameer Al-Sakran, Lee Jones: **Automated Re-Invention of Six Patented Optical Lens Systems using Genetic Programming**
 - Paul Massey, John A Clark, Susan Stepney: **Evolution of a Human-Competitive Quantum Fourier Transform Algorithm Using Genetic Programming**
 - Fulvio Corno, Edgar Ernesto, Sanchez Sanchez, Giovanni Squillero: **Evolving Assembly Programs: How Games Help Microprocessor Validation**

2005 Human-Competitive Awards in Genetic and Evolutionary Computation cont.

■ \$1000 – Silver

- Richard J. Terrile et al.:
 - Evolutionary Computation Technologies for the Automatic Design of Space Systems,
 - Evolutionary Computation applied to the Tuning of MEMS gyroscopes,
 - Multi-Objective Evolutionary Algorithms for Low-Thrust Orbit Transfer Optimization

■ \$500 – Bronze

- Moshe Sipper et al.: Attaining Human-Competitive Game Playing with Genetic Programming (Backgammon Players, Robocode Players, Chess Endgame)
- Uli Grasemann, Risto Miikkulainen: Effective Image Compression using Evolved Wavelets

■ Exploring different quantum behaviors in an fast automated fashion

- Bartels et al. use **an evolutionary optimization algorithm to shape laser pulses** to distort molecules in specific ways to catalyze chemical reactions, with the ultimate goal of manipulating large molecules, for example proteins and enzymes, in a biological cell.
- The method has also been used to create **new quantum behaviors** at the atomic level.
- The learning component is a relatively **simple evolution strategy**. A deformable mirror pulse shaper and an evolutionary strategy algorithm were then used to
 - selectively optimize the 27th harmonic,
 - while simultaneously suppressing the 25th and 29th orders.The optimum pulse shape is found after about 100 iterations of the learning algorithm, each of which consists of about 100 trials.
- Human can probe quantum systems, but are not capable of exploring different quantum behaviors in an fast automated fashion. In a sense, **the results are beyond human competitive.**

■ Exploring different quantum behaviors in an fast automated fashion

- There is also no doubt that this is a major scientific result which was achieved using evolutionary computation.
- The results are completely unexpected and amazing from a physical point of view: behaviors are being evolved that were not known to be physically possible. This includes anti-correlated attosecond harmonics in quantum systems. The ability to move beyond the nanoscale to the attoscale is a major breakthrough, and the potential applications of controlling the behavior of materials at atomic level are enormous.

2006 Human-Competitive Awards in Genetic and Evolutionary Computation

- <http://www.genetic-programming.org/hc2006/cfe2006.html>
- **\$5000 – Gold**
 - Varun Aggarwal et al.: **Catalogue of Variable Frequency and Single-Resistance-Controlled Oscillators Employing A Single Differential Difference Complementary Current Conveyor**
- **\$3000 – Silver**
 - Kumara Sastry et al.: **Multiobjective Genetic Algorithms for Multiscaling Excited-State Direct Dynamics in Photochemistry**
- **\$1000 – Bronze**
 - Jie Yao et al.: **A multi-population genetic algorithm for robust and fast ellipse detection**
 - Gustavo Olague, Leonardo Trujillo:
 - **Using Evolution to Learn How to Perform Interest Point Detection**
 - **Synthesis of Interest Point Detectors Through Genetic Programming**

The winner of Humies 2006

- Selcuk Kilinc et al: **Catalogue of Variable Frequency and Single-Resistance-Controlled Oscillators Employing a Single Differential Difference Complementary Current Conveyor**
reference: http://web.mit.edu/varun_ag/www/hc-2006.html
- Sine-wave oscillators have various applications:
 - Communication systems,
 - Control and measurement,
 - Signal processing, etc.
- Interest in design of inductorless low power and low area oscillators
- Oscillator Design: How?
 - Human designed: Adhoc, intuition, analysis.
 - Exhaustive approaches: Mathematically rigorous. Infeasible with size/topological constraints.
 - Explore a small topological space manually
 - Fixed connection and different elements
 - Use of specific design principle

Oscillators

- **Genetic Algorithm:**
 - Push button approach to oscillator synthesis, Automatic, No human designer, No mathematics, Looks at complete search space, Scaleable.
 - **Can it find new design ideas?**
- GA evolved a catalogue of sinusoidal oscillators with single resistor frequency control, that use only a single active building block (ABB) and minimum number of passive components.

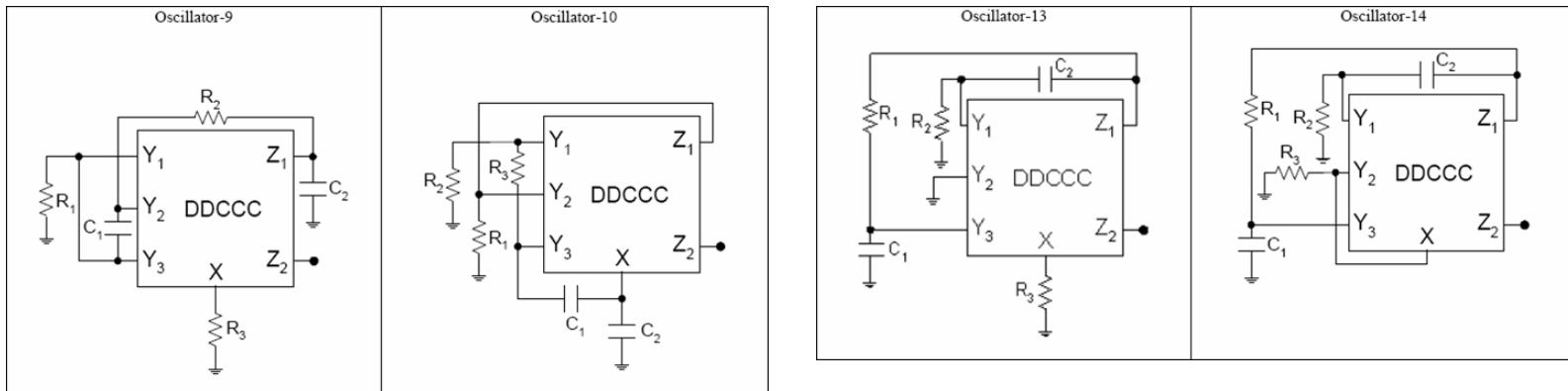

- **Value of result**
 - Design beyond expectation, new design principles
 - Human interpretable and SPICE validated
 - Improvement over the state-of-art: Lower in power and area.



2007 Human-Competitive Awards in Genetic and Evolutionary Computation

- <http://www.genetic-programming.org/hc2007/cfe2007.html>
- **\$5000 – Gold**
 - Steven Manos et al.: **Evolutionary Design of Single-Mode Microstructured Polymer Optical Fibres using an Artificial Embryogeny Representation**
- **\$3000 – Silver**
 - Ami Hauptman, Moshe Sipper: **Evolution of an Efficient Search Algorithm for the Mate-In-N Problem in Chess**
- **\$1000 – Bronze**
 - Jaume Bacardit et al.: **Automated Alphabet Reduction Method with Evolutionary Algorithms for Protein Structure Prediction**
 - Xavier Llorà et al.: **Towards Better than Human Capability in Diagnosing Prostate Cancer Using Infrared Spectroscopic Imaging**

Evolutionary Design of Single-Mode Microstructured Polymer Optical Fibres

- Steven Manos, Leon Poladian, Maryanne Large: **Evolutionary Design of Microstructured Polymer Optical Fibres using an Artificial Embryogeny Representation**

reference: <http://www.genetic-programming.org/hc2007/cfe2007.html>

- Applications of optical fibres
 - Long distance telecommunications
 - Computer networks
 - Automotive and aeronautical
 - Electrical current measurement
 - Temperature and strain sensing
 - Medical (lasers and endoscopy)
- The behaviour of light depends on this internal structure

New functionality = more complex designs?

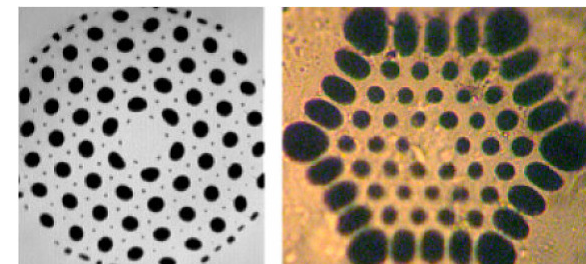
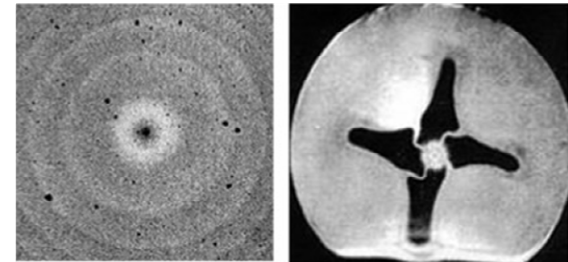
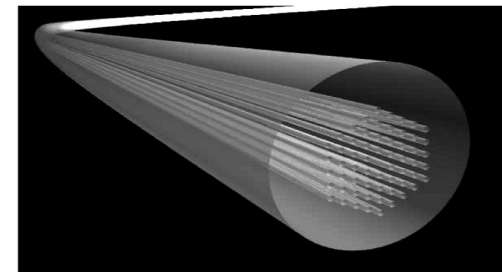

Single-moded fibres

Typical hexagonal design

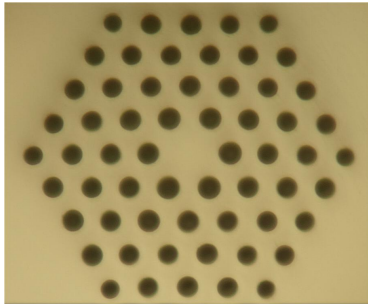

Standard design since the early 1990's

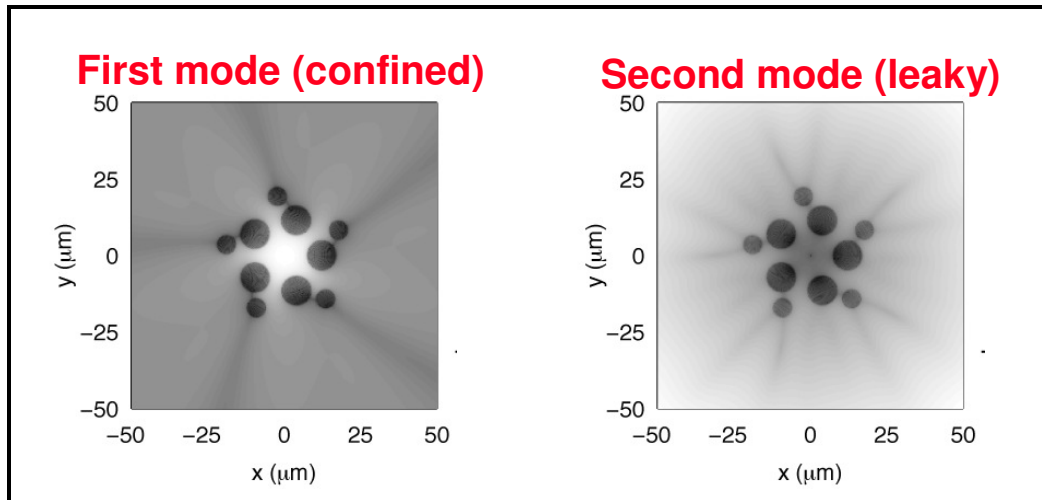

Single-moded operation

- Single-moded fibres support the propagation of only the fundamental mode.
- These fibres are important in applications such as high-bandwidth communications, temperature sensing and strain sensing.
- By discovering fibres that don't have a typical hexagonal design, we can start doing more interesting things with them.

Evolved single-mode designs

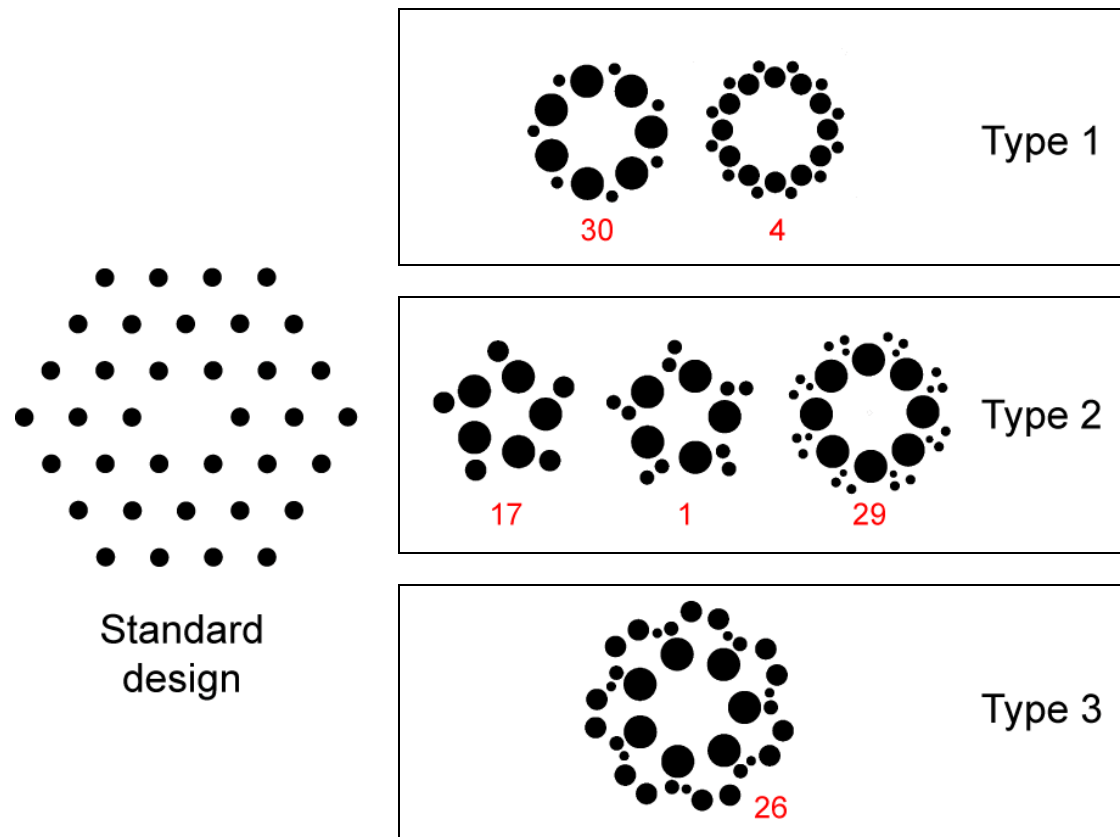

All designs have confined fundamental modes with $l_{c,1} < 10^{-1}$ dB/m, with losses more typically being $l_{c,1} < 10^{-3}$ dB/m.

The loss of the second mode $l_{c,2} > 10^4$ dB/m in all cases.

All single-moded, yet phenotypically different.

Manufactured single-mode MPOF

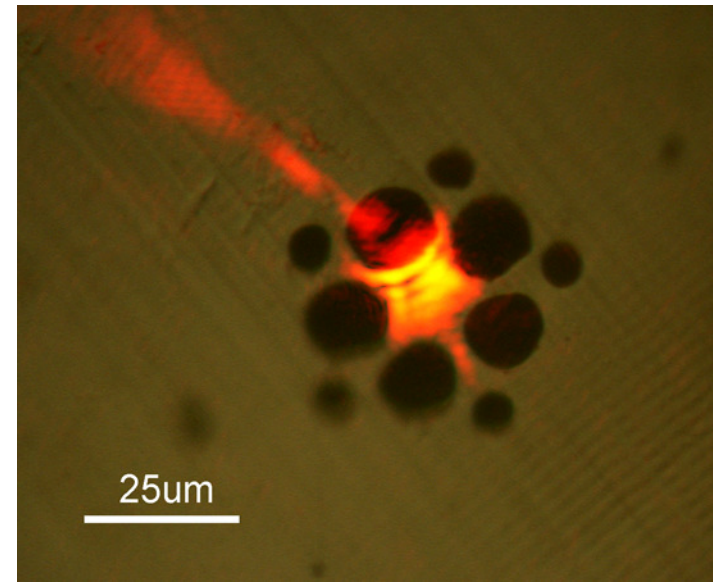
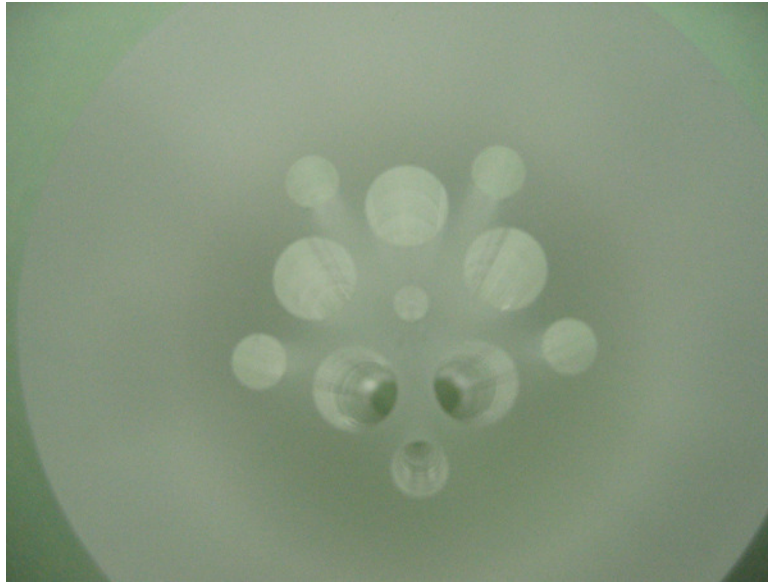

- Evolved designs are simpler than previous designs, and easier to manufacture.
- Provided us with a rich set of never before seen single-moded microstructured fibre designs to investigate further.

A different fitness function

- **Highly multi-moded fibres** designed for use in LANs and other short-distance high-bandwidth applications.

'GIMP 1'

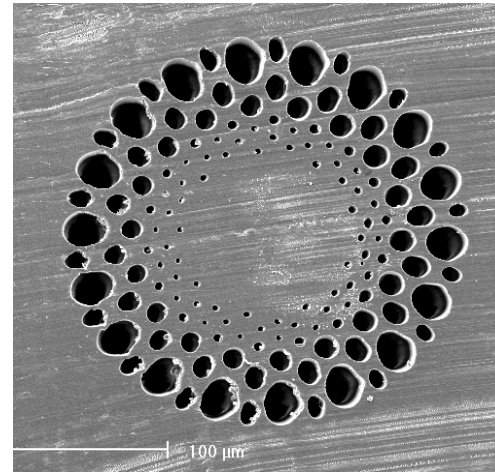
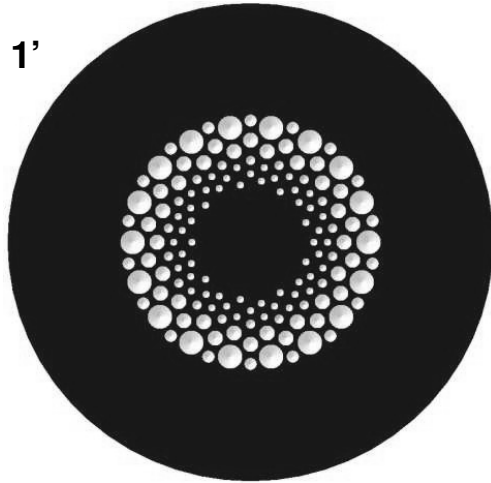

Hand-designed fibre

'GIMP 3'

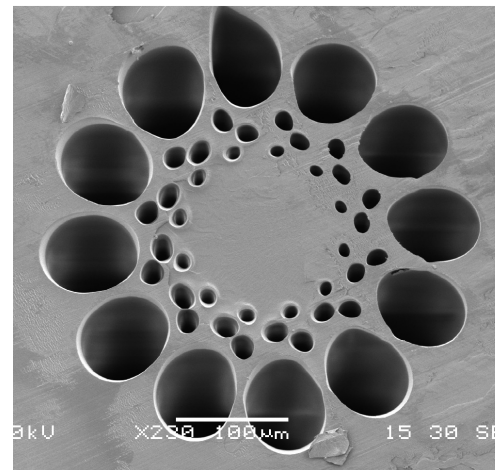
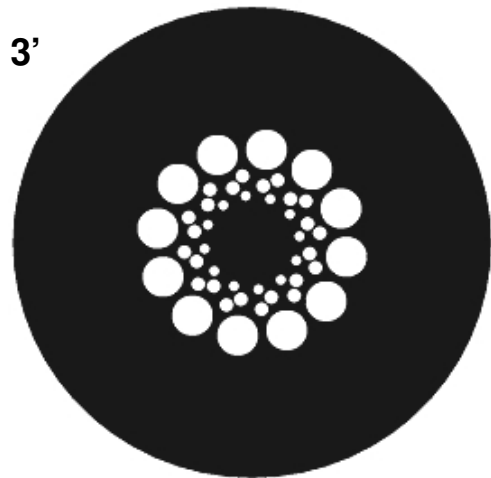

Patented GA-designed
fewer holes, easier to
manufacture.



2008 Human-Competitive Awards in Genetic and Evolutionary Computation

- <http://www.genetic-programming.org/hc2008/cfe2008.html>
- **\$5000 – Gold**
 - L. Spector, D. M. Clark, I. Lindsay, B. Barr, J. Klein: **Genetic Programming for Finite Algebras**
- **\$3000 – Silver**
 - T. Pecenka, Z. Kotasek, L. Sekanina: **Evolution of Synthetic RTL Benchmark Circuits with Predefined Testability**
- **\$1000 – Bronze**
 - A. Glazer, M. Sipper: **Evolving an automatic defect classification tool**



2009 Human-Competitive Awards in Genetic and Evolutionary Computation

- <http://www.genetic-programming.org/hc2009/cfe2009.html>
- **\$5000 – Gold**
 - S. Forrest, C. Le Goues, T. Nguyen, W. Weimer: **A Genetic Programming Approach to Automated Software Repair**
- **\$3000 – Silver**
 - M. Shahzad, S. Zahid, M. Farooq, S. Ali Khayam: **A Hybrid GA-PSO Fuzzy System for User Identification on Smart Phones**
- **\$1000 – Bronze**
 - A. Hauptman, A. Elyasaf, M. Sipper, A. Karmon: **GP-Rush: Using Genetic Programming to Evolve Solvers for the Rush Hour Puzzle**
 - C. B. Perez, G. Olague: **Learning Invariant Region Descriptor Operators with Genetic Programming and the F-measure**