

Parallel Programming

Jan Faigl

Department of Computer Science

Faculty of Electrical Engineering

Czech Technical University in Prague

Lecture 07

B3B36PRG – Programming in C



Overview of the Lecture

- Part 1 – Introduction to Parallel Programming

Introduction

Parallel Processing

Semaphores

Shared Memory

Messages

Parallel Computing using GPU (optional)



Part I

Part 1 – Introduction to Parallel Programming



Outline

Introduction

Parallel Processing

Semaphores

Shared Memory

Messages

Parallel Computing using GPU (optional)



Parallel Programming

- The idea of parallel programming comes from the 60s with the first multi-program and pseudo-parallel systems.
- Parallelism can be hardware or software based.
 - Hardware based – true hardware parallelism of multiprocessor systems.
 - Software based – pseudo-parallelism.
- Pseudo-parallelism – A program with parallel constructions may run in pseudo-parallel environment on single or multi-processor systems.



Motivation Why to Deal with Parallel Programming

- Increase computational power.
 - Having multi-processor system we can solve the computational problem faster.
- Efficient usage of the computational power.
 - Even a running program may wait for data.
 - E.g., a usual program with user-interaction typically waits for the user input.
- Simultaneous processing of many requests.
 - Handling requests from individual clients in client/server architecture.



Process – Executed Program

- Process is executed program running in a dedicated memory space.
- Process is an entity of the Operating System (OS) that is schedule for independent execution.
- Process is usually in one of three basic states:
 - Executing – currently running on the processor (CPU);
 - Blocked – waiting for the periphery;
 - Waiting – waiting for the processor .
- A process is identified in the OS by its identifier, e.g., Process IDentifier PID.
- Scheduler of the OS manage running processes to be allocated to the available processors.



Process States

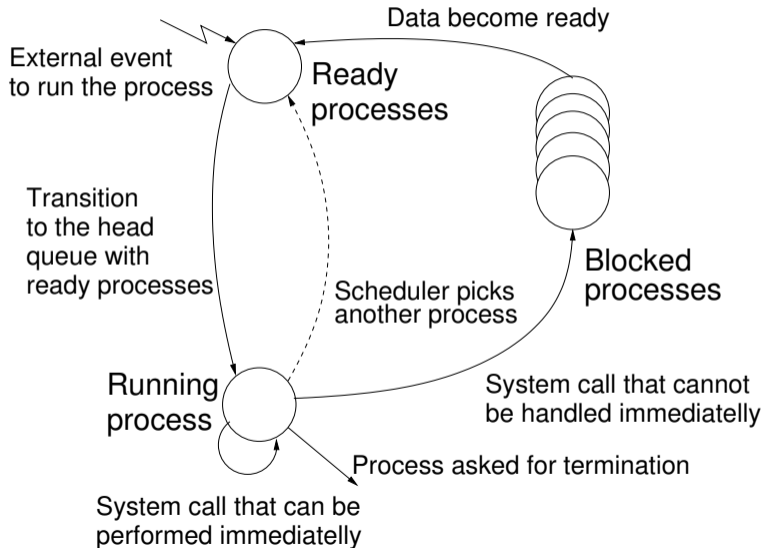

Multi-processor Systems

- Multi-processor systems allow true parallelism.
- It is necessary to synchronize processors and support data communication.
 - Resources for activity synchronization.
 - Resources for communication between processors (processes).



Possible Architectures for Parallel Executions

- Control of individual instructions.
 - **SIMD** – Single-Instruction, Multiple-Data – same instructions are simultaneously performed on different data.
 - “Processors” are identical and run synchronously.
 - E.g., “Vectorization” such as MMX, SSE, 3Dnow!, and AVX, AVX2, etc.
 - **MIMD** – Multiple-Instruction, Multiple-Data – processors run independently and asynchronously.
- Memory Control Access.
 - Systems with shared memory – central shared memory.

E.g., multi-core CPUs.
 - Systems with distributed memory – each processor has its memory.

E.g., computational grids.



SIMD – Single-Instruction, Multiple-Data

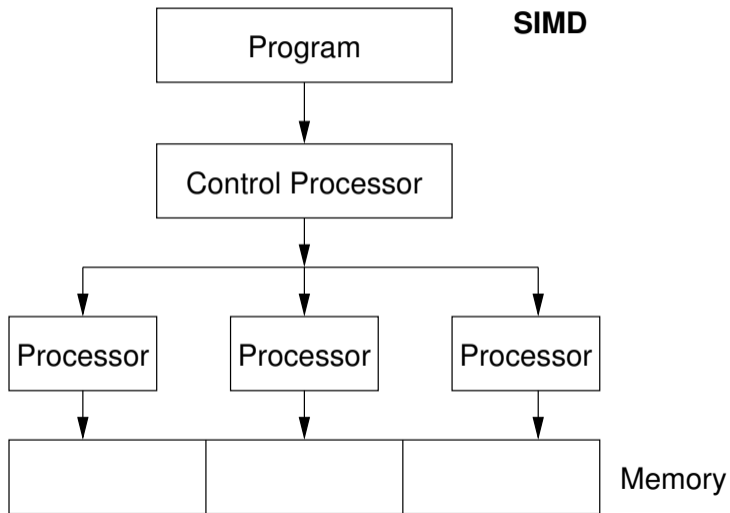

MIMD – Multiple-Instruction, Multiple-Data

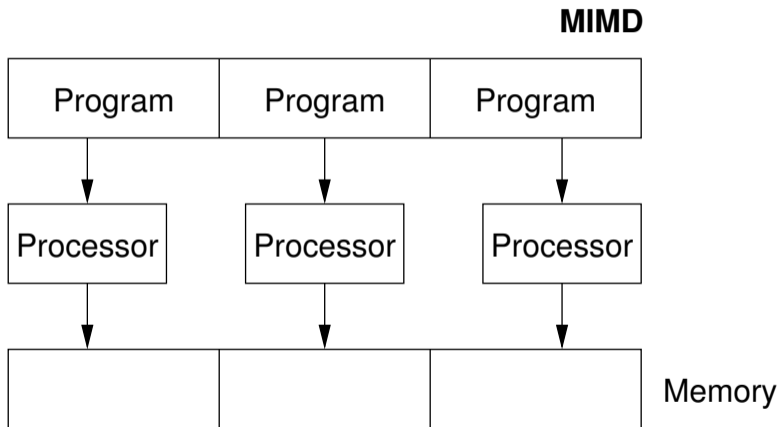

Systems with Shared Memory

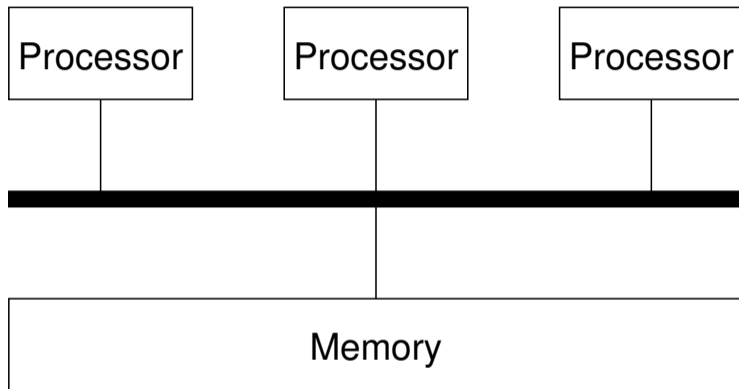

- Processors communicate using shared memory space.
- Processors may also synchronize their activities, i.e., granting exclusive access to the memory.



Systems with Distributive Memory

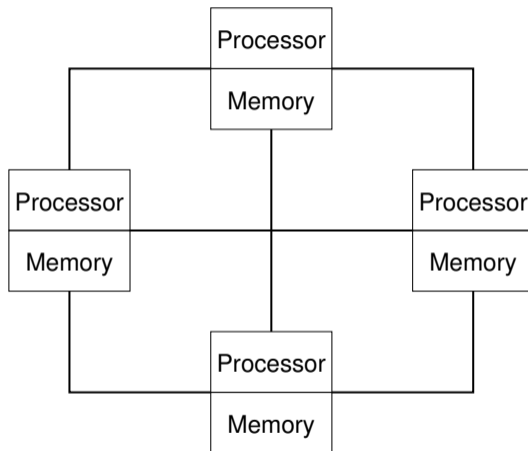

- There is not a problem with exclusive access to the memory.
- It is necessary to address communication between the processors.



The Role of the Operating System (OS)

- OS provides hardware abstraction layer – encapsulate HW and separate the user from the particular hardware architecture (true/pseudo parallelism).
- OS is responsible for synchronization of running processes.
- OS provides user interfaces (system calls).
 - To **create** and destroy processes.
 - To **manage** processes and processors.
 - To **schedule** processors on available processors.
 - To control access to **shared memory**.
 - Mechanisms for inter-process **communication** (IPC).
 - Mechanisms for processes **synchronization**.



Outline

Introduction

Parallel Processing

Semaphores

Shared Memory

Messages

Parallel Computing using GPU (optional)



Parallel Processing and Programming Languages

- Regarding parallel processing programming languages can be divided into languages w/o and with explicit support for the parallelism.
 - Without explicit support for parallelism – possible mechanisms of parallel processing.
 1. Parallel processing is realized by compiler and operating system.
 2. Parallel constructions are explicitly marked for the compiler.
 3. Parallel processing is performed by OS system calls.
 - With explicit support for parallelism.



Example of Parallel Processing Realized by Compiler 1/2

Example – Array Multiplication

```
1  #include "my_malloc.h"
   #define SIZE 30000000
   int main(int argc, char *argv[])
6  {
7      int i;
8      int *in1 = (int*)myMalloc(SIZE * sizeof(int));
9      int *in2 = (int*)myMalloc(SIZE * sizeof(int));
10     int *out = (int*)myMalloc(SIZE * sizeof(int));
11     for (i = 0; i < SIZE; ++i) {
12         in1[i] = i;
13         in2[i] = 2 * i;
14     }
15     for (i = 0; i < SIZE; ++i) {
16         out[i] = in1[i] * in2[i];
17         out[i] = out[i] - (in1[i] + in2[i]);
18     }
19     return 0;
20 }
```



Example of Parallel Processing Realized by Compiler 2/2

Example 1

```
1 icc compute.c
2 time ./a.out
4 real 0m0.562s
5 user 0m0.180s
6 sys 0m0.384s
```

Example 2

```
1 icc -msse compute.c; time ./a.out
2 compute.c(8) : (col. 2) remark: LOOP WAS VECTORIZED.
4 real 0m0.542s
5 user 0m0.136s
6 sys 0m0.408s
```

Example 3

```
1 icc -parallel compute.c; time ./a.out
2 compute.c(12) : (col. 2) remark: LOOP WAS AUTO-PARALLELIZED.
4 real 0m0.702s
5 user 0m0.484s
6 sys 0m0.396s
```



Example – Open MP – Matrix Multiplication 1/2

- Open Multi-Processing (OpenMP) - application programming interface for multi-platform shared memory multiprocessing. <http://www.openmp.org>
- We can instruct the compiler by macros for parallel constructions, such as parallelization over the outside loop for the i variable.

```
1 void multiply(int n, int a[n][n], int b[n][n], int c[n][n])
2 {
3     int i;
4     #pragma omp parallel private(i)
5     #pragma omp for schedule (dynamic, 1)
6     for (i = 0; i < n; ++i) {
7         for (int j = 0; j < n; ++j) {
8             c[i][j] = 0;
9             for (int k = 0; k < n; ++k) {
10                c[i][j] += a[i][k] * b[k][j];
11            }
12        }
13    }
14 }
```

[lec07/demo-omp-matrix.c](#)

Squared matrices of the same dimensions are used for simplicity.



Example – Open MP – Matrix Multiplication 2/2

- Comparison of matrix multiplication with 1000×1000 matrices using OpenMP on iCore5 (2 cores with HT).

```

1 gcc -std=c99 -O2 -o demo-omp demo-omp-matrix.c -fopenmp
2 ./demo-omp 1000
3 Size of matrices 1000 x 1000 naive
4   multiplication with  $O(n^3)$ 
5 c1 == c2: 1
6 Multiplication single core 9.33 sec
7 Multiplication multi-core 4.73 sec
8
9 export OMP_NUM_THREADS=2
10 ./demo-omp 1000
11 Size of matrices 1000 x 1000 naive
12   multiplication with  $O(n^3)$ 
13 c1 == c2: 1
14 Multiplication single core 9.48 sec
15 Multiplication multi-core 6.23 sec

```

```

TOP (talirinde)
last pid: 3219; load averages: 0.31, 0.29, 0.23 up 0+18:22:15 08:24:22
99 processes: 5 running, 94 sleeping
CPU: 99.8% user, 0.0% nice, 0.1% system, 0.1% interrupt, 0.0% idle
Mem: 86M Active, 1346M Inact, 775M Wired, 4188K Cache, 806M Buf, 5515M Free
Swap:

```

PID	USERNAME	PRI	NICE	SIZE	RES	STATE	C	TIME	WCPU	COMMAND
3219	jf	93	0	33416K	16532K	CPU2	2	0:12	74.76%	demo-omp{demo-
3219	jf	93	0	33416K	16532K	CPU1	1	0:03	74.76%	demo-omp{demo-
3219	jf	93	0	33416K	16532K	CPU3	3	0:03	74.76%	demo-omp{demo-
3219	jf	93	0	33416K	16532K	RUN	0	0:03	74.66%	demo-omp{demo-
777	root	20	0	14492K	1964K	select	1	0:03	0.00%	powerd
3113	jf	20	0	30192K	6356K	pause	2	0:03	0.00%	zsh
819	root	20	0	178M	35944K	select	2	0:03	0.00%	Xorg
3070	jf	20	0	182M	23836K	select	2	0:02	0.00%	gkrellm{gkrell
774	root	20	0	26160K	18100K	select	3	0:02	0.00%	ntpd{ntpd}
774	root	20	0	26160K	18100K	kqread	3	0:01	0.00%	ntpd{ntpd}
3078	jf	20	0	361M	62472K	select	1	0:01	0.00%	owncloud{owncl
3154	jf	20	0	29944K	5992K	pause	0	0:01	0.00%	zsh
3160	jf	25	5	21940K	3564K	select	0	0:01	0.00%	top
487	_pflogd	20	0	14700K	2332K	bpf	0	0:01	0.00%	pflogd
3096	jf	33	0	30028K	5956K	ttyin	0	0:01	0.00%	zsh
864	root	20	0	148M	8988K	select	0	0:01	0.00%	htpd
3153	jf	20	0	86504K	7508K	select	1	0:01	0.00%	sshd

Use, e.g., top program for a list of running processes/threads.

lec07/demo-omp-matrix.c



Languages with Explicit Support for Parallelism

- It has support for creation of new processes.
 - Running process create a copy of itself.
 - Both processes execute the identical code (copied).
 - The **parent** process and **child** process are distinguished by the process identifier (PID).
 - The code segment is explicitly linked with the new process.
- Regardless how a new process is created, the most important is the relation to the parent process execution and memory access.
 - Does the parent process stops its execution till the end of the child process?
 - Is the memory shared by the child and parent processes?
- Granularity of the processes – parallelism ranging from the level of the instructions to the parallelism of programs.



Parallelism – Statement Level

Example – parbegin-parend block

parbegin

S_1 ;

S_2 ;

...

S_n

parend

- Statement S_1 are S_n executed in parallel.
- Execution of the main program is interrupted until all statements S_1 to S_n are terminated.
- Statement S_1 are S_n executed in parallel.

Example – doparallel

```

1 for i = 1 to n doparallel {
2     for j = 1 to n do {
3         c[i,j] = 0;
4         for k = 1 to n do {
5             c[i,j] = c[i,j] + a[i,k]*b[k,j];
6     } } }
```

Parallel execution of the outer loop over all i .

E.g., OpenMP in C.



Parallelism – Procedure Level

- A procedure is coupled with the execution process.

...

```
procedure P;
```

...

```
PID  $x_{pid}$  = newprocess(P);
```

...

```
killprocess( $x_{pid}$ );
```

- P is a procedure and x_{pid} is a process identifier.
- Assignment of the procedure/function to the process at the declaration

```
PID  $x_{pid}$  process(P).
```

- The process is created at the creation of the variable x .
- The process is terminated at the end of x or sooner.

E.g., Threads (pthreads) in C.



Parallelism – Program (Process) Level

- A new process can be only a whole program.
- A new program is created by a system call, which creates a complete copy of itself including all variable and data at the moment of the call.

Example - Creating a copy of the process by fork system call

```
1  if (fork() == 0) {  
2      /* code executed by the child process */  
3  } else {  
4      /* code executed by the parent process */  
5  }
```

E.g., fork() in C



Example – fork()

```

1  #define NUMPROCS 4
2  for (int i = 0; i < NUMPROCS; ++i) {
3      pid_t pid = fork();
4      if (pid == 0) {
5          compute(i, n);
6          exit(0);
7      } else {
8          printf("Child %d created\n", pid);
9      }
10 }
11 printf("All processes created\n");
12 for (int i = 0; i < NUMPROCS; ++i) {
13     pid_t pid = wait(&r);
14     printf("Wait for pid %d return: %d\n", pid, r);
15 }
16 void compute(int myid, int n)
17 {
18     printf("Process myid %d start computing\n", myid);
19     ...
20     printf("Process myid %d finished\n", myid);
21 }

```

lec07/demo-fork.c

```

clang demo-fork.c && ./a.out
Child 2049 created
Process myid 0 start computing
Child 2050 created
Process myid 1 start computing
Process myid 2 start computing
Child 2051 created
Child 2052 created
Process myid 3 start computing
All processes created
Process myid 1 finished
Process myid 0 finished
Wait for pid 2050 return: 0
Process myid 3 finished
Process myid 2 finished
Wait for pid 2049 return: 0
Wait for pid 2051 return: 0
Wait for pid 2052 return: 0

```



Outline

Introduction

Parallel Processing

Semaphores

Shared Memory

Messages

Parallel Computing using GPU (optional)



Semaphore

- E. W. Dijkstra – semaphore is a mechanism to synchronize parallel processes with shared memory.
- Semaphore is an integer variable with the following operations.
 - *InitSem* - initialization.
 - *Wait*
 - ⎧ If $S > 0$ then $S \leftarrow S - 1$ (*resources are available, in this case, acquire one*).
 - ⎨ Otherwise suspend execution of the calling process (*wait for S become $S > 0$*).
 - *Signal*
 - ⎧ If there is a waiting process, awake it (*let the process acquire one resource*).
 - ⎨ Otherwise increase value of S by one, i.e., $S \leftarrow S + 1$ (*release one resource*).
- Semaphores can be used to control access to shared resource.
 - $S < 0$ – shared resource is in use. The process asks for the access to the resources and waits for its release.
 - $S > 0$ - shared resource is available. The process releases the resource.

The value of the semaphore can represent the number of available resources. Then, we can acquire (or wait for) k resources – $wait(k): S \leftarrow S - k$ for $S > k$, and also releases k resources – $signal(k): S \leftarrow S + k$.



Semaphores Implementation

- Operations with a semaphore must be atomic.

The processor cannot be interrupted during execution of the operation.

- Machine instruction *TestAndSet* reads and stores a content of the addressed memory space and set the memory to a non-zero value.
- During execution of the *TestAndSet* instructions the processor holds the system bus and access to the memory is not allowed for any other processor.



Usage of Semaphores

- Semaphores can be utilized for defining a **critical sections**.
- Critical sections is a part of the program where exclusive access to the shared memory (resources) must be guaranteed.

Example of critical section protected by a semaphore

```
InitSem(S,1);  
Wait(S);  
/* Code of the critical section */  
Signal(S);
```

- Synchronization of the processes using semaphores.

Example of synchronization of processes.

```
/* process p */  
...  
InitSem(S,0)  
Wait(S); ...  
exit();
```

```
/* process q */  
...  
Signal(S);  
exit();
```



Example – Semaphore 1/4 (System Calls)

- Semaphore is an entity of the Operating System (OS).

```
1 #include <sys/types.h>
2 #include <sys/ipc.h>
3 #include <sys/sem.h>
   /* create or get existing set of semphores */
6 int semget(key_t key, int nsems, int flag);
   /* atomic array of operations on a set of semphores */
9 int semop(int semid, struct sembuf *array, size_t nops);
   /* control operations on a st of semaphores */
12 int semctl(int semid, int semnum, int cmd, ...);
```



Example – Semaphore 2/4 (Synchronization Protocol)

- Example when the main (primary) process waits for two other processes (secondary) become ready.
 1. *Primary* process suspend the execution and waits for two other *secondary* processes become ready.
 2. *Secondary* processes then wait to be released by the primary process.
- Proposed synchronization “protocol”.
 - Define our way to synchronize the processes using the system semaphores.
 - Secondary process increments semaphore by 1.
 - Secondary process waits the semaphore become 0 and then it is terminated.
 - Primary process waits for two secondary processes and decrements the semaphore about 2.
 - It must also ensure the semaphore value is not 0; otherwise secondary processes would be terminated prematurely.
 - We need to use the atomic operations with the semaphore.

[lec07/sem-primary.c](#) [lec07/sem-secondary.c](#)



Example – Semaphore 3/4 (Primary Process)

```
1 int main(int argc, char* argv[])
2 {
3     struct sembuf sem[2]; // structure for semaphore atomic operations
4     int id = semget(1000, 1, IPC_CREAT | 0666); // create semaphore
5     if (id != -1) {
6         int r = semctl(id, 0, SETVAL, 0) == 0;
7         sem[0].sem_num = 0; // operation to acquire semaphore
8         sem[0].sem_op = -2; // once its value will be >= 2
9         sem[0].sem_flg = 0; // representing two secondary processes are ready
10        sem[1].sem_num = 0; // the next operation in the atomic set
11        sem[1].sem_op = 2; // of operations increases the value of
12        sem[1].sem_flg = 0; // the semaphore about 2
13        printf("Wait for semvalue >= 2\n");
14        r = semop(id, sem, 2); // perform all (two) operations (in sem array) atomically
15        printf("Press ENTER to set semaphore to 0\n");
16        getchar();
17        r = semctl(id, 0, SETVAL, 0) == 0; // set the value of semaphore
18        r = semctl(id, 0, IPC_RMID, 0) == 0; // remove the semaphore
19    }
20    return 0;
21 }
22
23
24 }
```

lec07/sem-primary.c



Example – Semaphore 4/4 (Secondary Process)

```
1 int main(int argc, char* argv[])
2 {
3     struct sembuf sem;
4     int id = semget(1000, 1, 0);
5     int r;
6     if (id != -1) {
7         sem.sem_num = 0; // add the secondary process
8         sem.sem_op = 1; // to the "pool" of resources
9         sem.sem_flg = 0;
10        printf("Increase semaphore value (add resource)\n");
11        r = semop(id, &sem, 1);
12        sem.sem_op = 0;
13        printf("Semaphore value is %d\n", semctl(id, 0, GETVAL, 0));
14        printf("Wait for semaphore value 0\n");
15        r = semop(id, &sem, 1);
16        printf("Done\n");
17    }
18    return 0;
19 }
```

lec07/sem-secondary.c

- The IPC entities can be listed by `ipcs`.

```
clang sem-primary.c -o sem-primary
clang sem-secondary.c -o sem-secondary
```



Issues with Semaphores

- The main issues are arising from a wrong usage.
- Typical mistakes are as follows.
 - Wrongly identified a critical section.
 - Process may block by multiple calls of `Wait(S)`.
 - E.g., the **deadlock** issues may arise from situations like.

Example – Deadlock

```
/* process 1*/  
...  
Wait(S1);  
Wait(S2);  
...  
Signal(S2);  
Signal(S1);  
...
```

```
/* process 2*/  
...  
Wait(S2);  
Wait(S1);  
...  
Signal(S1);  
Signal(S2);  
...
```



Outline

Introduction

Parallel Processing

Semaphores

Shared Memory

Messages

Parallel Computing using GPU (optional)



Shared Memory

- Labeled part of the memory accessible from different processes.
- OS service provided by system calls.

Example of System Calls

```
1  /* obtain a shared memory identifier */
2  int shmget(key_t key, size_t size, int flag);
   /* attach shared memory */
5  void* shmat(int shmid, const void *addr, int flag);
   /* detach shared memory */
8  int shmdt(const void *addr);
   /* shared memory control */
11 int shmctl(int shmid, int cmd, struct shmid_ds *buf);
```

- OS manages information about usage of shared memory.
- OS also manages permissions and access rights.



Example – Shared Memory 1/4 (Write)

- Write a line read from `stdin` to the shared memory.

```
1 #include <sys/types.h>
2 #include <sys/ipc.h>
3 #include <sys/shm.h>
4 #include <stdio.h>
5 #define SIZE 512
6 int main(int argc, char *argv[])
9 {
10     char *buf;
11     int id;
12     if ((id = shmget(1000, SIZE, IPC_CREAT | 0666)) != -1) {
13         if ( (buf = (char*)shmat(id, 0, 0)) ) {
14             fgets(buf, SIZE, stdin);
15             shmdt(buf);
16         }
17     }
18     return 0;
19 }
```



Example – Shared Memory 2/4 (Read)

- Read a line from the shared memory and put it to the `stdout`.

```
1 #include <sys/types.h>
2 #include <sys/shm.h>
3 #include <stdio.h>
4 #define SIZE 512
5 int main(int argc, char *argv[])
6 {
7     int id;
8     char *buf;
9     if ((id = shmget(1000, 512, 0)) != -1) {
10         if ((buf = (char*)shmat(id, 0, 0)) ) {
11             printf("mem:%s\n", buf);
12         }
13         shmdt(buf);
14     } else {
15         fprintf(stderr, "Cannot access to shared memory!\n");
16     }
17     return 0;
18 }
```

lec07/shm-read.c



Example – Shared Memory 3/4 (Demo)

1. Use `shm-write` to write a text string to the shared memory.
2. Use `shm-read` to read data (string) from the shared memory.
3. Remove shared memory segment.

```
ipcrm -M 1000
```

4. Try to read data from the shared memory.

```
1 % clang -o shm-write shm-write.c
2 % ./shm-write
3 Hello! I like programming in C!
```

```
1 % clang -o shm-read shm-read.c
2 % ./shm-read
3 mem:Hello! I like programming in C!
5 % ./shm-read
6 mem:Hello! I like programming in C!
8 % ipcrm -M 1000
9 % ./shm-read
10 Cannot access to shared memory!
```

```
lec07/shm-write.c lec07/shm-read.c
```



Example – Shared Memory 4/4 (Status)

- A list of accesses to the shared memory using `ipcs` command.

```

1  after creating shared memory segment and before writing the text
2  m          65539          1000 --rw-rw-rw-    jf    jf    jf    jf
   1          512            1239            1239 22:18:48 no-entry 22:18:48
4  after writing the text to the shared memory
5  m          65539          1000 --rw-rw-rw-    jf    jf    jf    jf
   0          512            1239            1239 22:18:48 22:19:37 22:18:48
7  after reading the text
8  m          65539          1000 --rw-rw-rw-    jf    jf    jf    jf
   0          512            1239            1260 22:20:07 22:20:07 22:18:48

```



Outline

Introduction

Parallel Processing

Semaphores

Shared Memory

Messages

Parallel Computing using GPU (optional)



Sensing Messages and Queues of Messages

- Processes can communicate via messages send/received to/from system messages queues.
- Queues are entities of the OS with defined system calls.

Example of System Calls

```
1 #include <sys/types.h>
2 #include <sys/ipc.h>
3 #include <sys/msg.h>
4 /* Create a new message queue */
5
6 int msgget(key_t key, int msgflg);
7 /* Send a message to the queue -- block/non-block (IPC_NOWAIT) */
8
9 int msgsnd(int msqid, const void *msgp, size_t msgsz, int msgflg);
10
11 /* Receive message from the queue -- block/non-block (IPC_NOWAIT) */
12 int msgrcv(int msqid, void *msgp, size_t msgsz, long msgtyp, int msgflg);
13
14 /* Control operations (e.g., destroy) the message queue */
15 int msgctl(int msqid, int cmd, struct msqid_ds *buf);
```

Another message passing system can be implemented by a user library, e.g., using network communication.



Example – Messages Passing 1/4 (Synchronization, Primary)

- Two processes are synchronized using messages.
 1. The **primary** process waits for the message from the **secondary** process
 2. The primary process informs secondary to solve the task.
 3. The secondary process informs primary about the solution.
 4. The primary process sends message about termination.

Example of Master Process 1/2

```
1 struct msgbuf {
2     long mtype;
3     char mtext[SIZE];
4 };
5 int main(int argc, char *argv[])
6 {
7     struct msgbuf msg;
8     int id = msgget(KEY, IPC_CREAT | 0666);
9     int r;
10    if (id != -1) {
```



Example – Messages Passing 2/4 (Primary)

Example of Primary Process 2/2

```
1  msg.mtype = 3; //type must be > 0
2  printf("Wait for other process \n");
3  r = msgrcv(id, &msg, SIZE, 3, 0);
4  printf("Press ENTER to send work\n");
5  getchar();
6  strcpy(msg.mtext, "Do work");
7  msg.mtype = 4; //work msg is type 4
8  r = msgsnd(id, &msg, sizeof(msg.mtext), 0);
9  fprintf(stderr, "msgsnd r: %d\n",r);
10 printf("Wait for receive work results\n",r);
11 msg.mtype = 5;
12 r = msgrcv(id, &msg, sizeof(msg.mtext), 5, 0);
13 printf("Received message: %s\n", msg.mtext);
14 printf("Press ENTER to send exit msg\n");
15 getchar();
16 msg.mtype = EXIT_MSG; //I choose type 10 as exit msg
17 r = msgsnd(id, &msg, 0, 0);
18 }
19 return 0;
20 }
```

lec07/msg-primary.c



Example – Messages Passing 3/4 (Secondary)

```
1 int main(int argc, char *argv[])
2 {
3     ...
4     msg.mtype = 3;
5     printf("Inform main process\n");
6     strcpy(msg.mtext, "I'm here, ready to work");
7     r = msgsnd(id, &msg, sizeof(msg.mtext), 0);
8     printf("Wait for work\n");
9     r = msgrcv(id, &msg, sizeof(msg.mtext), 4, 0);
10    printf("Received message: %s\n", msg.mtext);
11    for (i = 0; i < 4; i++) {
12        sleep(1);
13        printf(".");
14        fflush(stdout);
15    } //do something useful
16    printf("Work done, send wait for exit\n");
17    strcpy(msg.mtext, "Work done, wait for exit");
18    msg.mtype = 5;
19    r = msgsnd(id, &msg, sizeof(msg.mtext), 0);
20    msg.mtype = 10;
21    printf("Wait for exit msg\n");
22    r = msgrcv(id, &msg, SIZE, EXIT_MSG, 0);
23    printf("Exit message has been received\n");
```

lec07/msg-secondary.c



Example – Messages Passing 4/4 (Demo)

1. Execute the primary process.
2. Execute the secondary process.
3. Perform the computation.
4. Remove the created message queue identified by the **msgid**.

```
#define KEY 1000
```

```
ipcrm -Q 1000
```

```
1 % clang msg-primary.c -o primary
2 % ./primary
3 Wait for other process
4 Worker msg received, press ENTER to
   send work msg
6 msgsnd r: 0
7 Wait for receive work results
8 Received message: I am going to wait
   for exit msg
9 Press ENTER to send exit msg
11 %ipcrm -Q 1000
12 %ipcrm -Q 1000
13 ipcrm: msqs(1000): : No such file or
   directory
14 %
```

```
1 % clang msg-secondary.c -o secondary
2 % ./secondary
3 Inform main process
4 Wait for work
5 Received message:Do work
6 ....done
7 Work done, send wait for exit
8 Wait for exit msg
9 Exit message has been received
10 %ipcs -q
11 Message Queues:
12 T ID    KEY  MODE    OWNER GROUP
13 q 65536 1000 -rw-rw- jf    jf
14 %
```

```
lec07/msg-primary.c  lec07/msg-secondary.c
```



Outline

Introduction

Parallel Processing

Semaphores

Shared Memory

Messages

Parallel Computing using GPU (optional)



Massive parallelism using graphics cards

- Image rendering performed pixel-by-pixel can be easily parallelized.
- Graphics Processing Units (GPU) has similar (or even higher) degree of integration with the main processors (CPU).
- They have huge number of parallel processors.

E.g., GeForce GTX 1060 ~ 1280 cores.

- The computational power can also be used in another applications.
 - Processing stream of data (SIMD instructions - processors).
 - GPGPU - General Purpose computation on GPU. <http://www.gpgpu.org>
 - OpenCL (Open Computing Language) – GPGPU abstract interface.
 - CUDA - Parallel programming interface for NVIDIA graphics cards.

http://www.nvidia.com/object/cuda_home.html



Computational Power (2008)

- What is the reported processor computational power?
- Graphics (stream) processors.

CSX700	96 GigaFLOPs	
Cell	102 GigaFLOPs	
GeForce 8800 GTX	518 GigaFLOPs	(including texture units)
Radeon HD 4670	480 GigaFLOPs	
GeForce RTX 4060	15 110 GigaFLOPs	(2023)

- Main processors :

Phenom X4 9950 (@2.6 GHz)	21 GigaFLOPs	
Core 2 Duo E8600 (@3.3 GHz)	22 GigaFLOPs	
Cure 2 Quad QX9650 (@3.3 GHz)	35 GigaFLOPs	
Cure 2 Quad QX9650 (@3.3 GHz)	35 GigaFLOPs	
Core i7 970 (@3.2 GHz)	42 GigaFLOPs	
Core i9-13900 (@2.00–5.60 GHz)	846 GigaFLOPs	(2023)

Peak catalogue values.

Test linpack 32-bit.

- Is the reported power really achievable?
- How about other indicators?
 - CSX700 has typical power consumption around 9W.

(float vs double)

E.g., computational power / power consumption.



CUDA

- NVIDIA Compute Unified Device Architecture.
- Extension of the C to access to the parallel computational units of the GPU.
- Computation (**kernel**) is executed by the GPU.
- Kernel is performed in parallel using available computational units.
- **Host** - Main processor (process).
- **Device** - GPU.
- Data must be in the memory accessible by the GPU.

Host memory → *Device memory*

- The result (of the computation) is stored in the GPU memory.

Host memory ← *Device memory*



CUDA – Computational Model

- Kernel (computation) is divided into blocks.
- Each block represent a parallel computation of the part of the result.
E.g., a part of the matrix multiplication.
- Each block consists of computational threads.
- Parallel computations are synchronization within the block.
- Blocks are organized into the **grid**.
- Scalability is realized by dividing the computation into blocks.

Blocks may not be necessarily computed in parallel. Based on the available number of parallel units, particular blocks can be computed sequentially.



CUDA – Grid, Blocks, Threads, and Memory Access

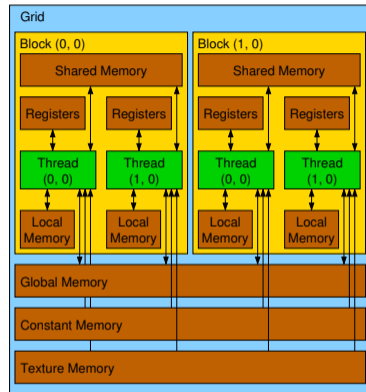
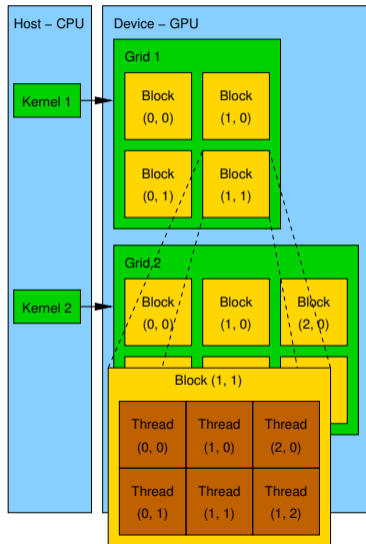

- Access time to the memory.
- Collisions for simultaneous access of several threads.



CUDA – Example – Matrix Multiplication 1/8

- NVIDIA CUDA SDK - Version 2.0, `matrixMul`.
- Simple matrix multiplication.
 - $C = A \cdot B$,
 - Matrices have identical dimensions $n \times n$,
 - where n is the multiple of the block size.
- Comparison
 - naive implementation in C ($3 \times$ *for loop*),
 - naive implementation in C with matrix transpose.
 - CUDA implementation.
- Hardware
 - CPU - Intel Core 2 Duo @ 3 GHz, 4 GB RAM,
 - GPU - NVIDIA G84 (GeForce 8600 GT), 512 MB RAM.



CUDA – Example – Matrix Multiplication 2/8

Naive implementation

```
1 void simple_multiply(const int n,  
2     const float *A, const float *B, float *C)  
3 {  
4     for (int i = 0; i < n; ++i) {  
5         for (int j = 0; j < n; ++j) {  
6             float prod = 0;  
7             for (int k = 0; k < n; ++k) {  
8                 prod += A[i * n + k] * B[k * n + j];  
9             }  
10            C[i * n + j] = prod;  
11        }  
12    }  
13 }
```



CUDA – Example – Matrix Multiplication 3/8

Naive implementation with transpose

```
1 void simple_multiply_trans(const int n, const float *a, const float *b, float *c)
2 {
3     float * bT = create_matrix(n);
4     for (int i = 0; i < n; ++i) {
5         bT[i*n + i] = b[i*n + i];
6         for (int j = i + 1; j < n; ++j) {
7             bT[i*n + j] = b[j*n + i];
8             bT[j*n + i] = b[i*n + j];
9         }
10    }
11    for (int i = 0; i < n; ++i) {
12        for (int j = 0; j < n; ++j) {
13            float tmp = 0;
14            for (int k = 0; k < n; ++k) {
15                tmp += a[i*n + k] * bT[j*n + k];
16            }
17            c[i*n + j] = tmp;
18        }
19    }
20    free(bT);
21 }
```



CUDA – Example – Matrix Multiplication 4/8

- CUDA – computation strategy
 - Divide matrices into blocks.
 - Each block computes a single sub-matrix C_{sub} .
 - Each thread of the individual blocks computes a single element of C_{sub} .

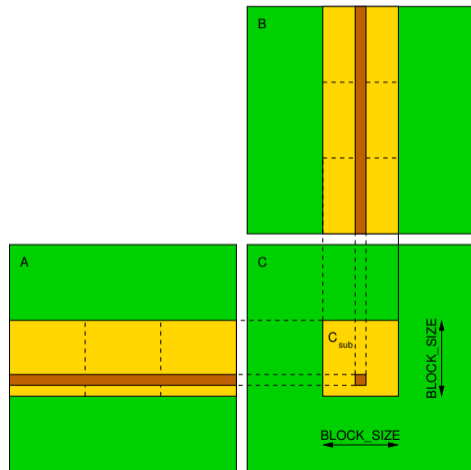

CUDA – Example – Matrix Multiplication 5/8

CUDA – Implementation – main function

```
1 void cuda_multiply(const int n, const float *hostA, const float *hostB, float *hostC)
2 {
3     const int size = n * n * sizeof(float);
4     float *devA, *devB, *devC;
5     cudaMalloc((void**)&devA, size);
6     cudaMalloc((void**)&devB, size);
7     cudaMalloc((void**)&devC, size);
8     cudaMemcpy(devA, hostA, size, cudaMemcpyHostToDevice);
9     cudaMemcpy(devB, hostB, size, cudaMemcpyHostToDevice);
10    dim3 threads(BLOCK_SIZE, BLOCK_SIZE); // BLOCK_SIZE == 16
11    dim3 grid(n / threads.x, n / threads.y);
12    // Call kernel function matrixMul
13    matrixMul<<<grid, threads>>>(n, devA, devB, devC);
14    cudaMemcpy(hostC, devC, size, cudaMemcpyDeviceToHost);
15    cudaFree(devA);
16    cudaFree(devB);
17    cudaFree(devC);
18 }
19 }
```



CUDA – Example – Matrix Multiplication 6/8

CUDA implementation – kernel function

```

1  __global__ void matrixMul(int n, float* A, float* B, float* C) {
2      int bx = blockIdx.x; int by = blockIdx.y;
3      int tx = threadIdx.x; int ty = threadIdx.y;
4      int aBegin = n * BLOCK_SIZE * by; //beginning of sub-matrix in the block
5      int aEnd = aBegin + n - 1; //end of sub-matrix in the block
6      float Csub = 0;
7      for (
8          int a = aBegin, b = BLOCK_SIZE * bx;
9          a <= aEnd;
10         a += BLOCK_SIZE, b += BLOCK_SIZE * n
11     ) {
12         __shared__ float As[BLOCK_SIZE][BLOCK_SIZE]; // shared memory within
13         __shared__ float Bs[BLOCK_SIZE][BLOCK_SIZE]; // the block
14         As[ty][tx] = A[a + n * ty + tx]; // each thread reads a single element
15         Bs[ty][tx] = B[b + n * ty + tx]; // of the matrix to the memory
16         __syncthreads(); // synchronization, sub-matrix in the shared memory
17         for (int k = 0; k < BLOCK_SIZE; ++k) { // each thread computes
18             Csub += As[ty][k] * Bs[k][tx]; // the element in the sub-matrix
19         }
20         __syncthreads();
21     }
22     int c = n * BLOCK_SIZE * by + BLOCK_SIZE * bx;
23     C[c + n * ty + tx] = Csub; // write the results to memory
24 }
25

```



CUDA – Example – Matrix Multiplication 7/8

- CUDA source codes.

Example – Dedicated source file `cuda_func.cu`

1. Declaration of the external function.

```
extern "C" { // declaration of the external function (cuda kernel)
    void cuda_multiply(const int n, const float *A, const float *B, float *C);
}
```

2. Compile the CUDA code to the C++ code.

```
1 nvcc --cuda cuda_func.cu -o cuda_func.cc
```

3. Compilation of the `cuda_func.cc` file using standard compiler.



CUDA – Example – Matrix Multiplication 8/8

Computational time (in milliseconds)

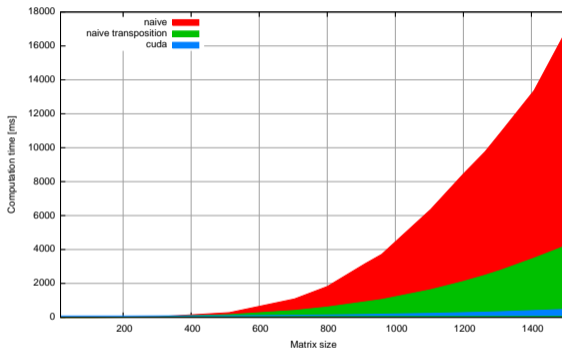

N	Naive	Transp.	CUDA	N	Naive	Transp.	CUDA
112	2	1	81	704	1083	405	122
208	11	11	82	1104	6360	1628	235
304	35	33	84	1264	9763	2485	308

- Matlab 7.6.0 (R2008a):
`n=1104; A=rand(n,n); B=rand(n,n); tic; C=A*B; toc`
 Elapsed time is 0.224183 seconds.



Summary of the Lecture



Topics Discussed

- Introduction to Parallel Programming
 - Ideas and main architectures
 - Program and process in OS
- Parallel processing
- Synchronization and Inter-Process Communication (IPC)
 - Semaphores
 - Messages
 - Shared memory
- *Parallel processing on graphics card (optional).*
- Next: Multithreading programming



Topics Discussed

- Introduction to Parallel Programming
 - Ideas and main architectures
 - Program and process in OS
- Parallel processing
- Synchronization and Inter-Process Communication (IPC)
 - Semaphores
 - Messages
 - Shared memory
- *Parallel processing on graphics card (optional).*

- **Next: Multithreading programming**

