

The story of the cat's brain surgery

**cortex, convolution layer, its vector-Jacobian, activation
functions**

Karel Zimmermann

Czech Technical University in Prague

Faculty of Electrical Engineering, Department of Cybernetics



Fully connected neural network

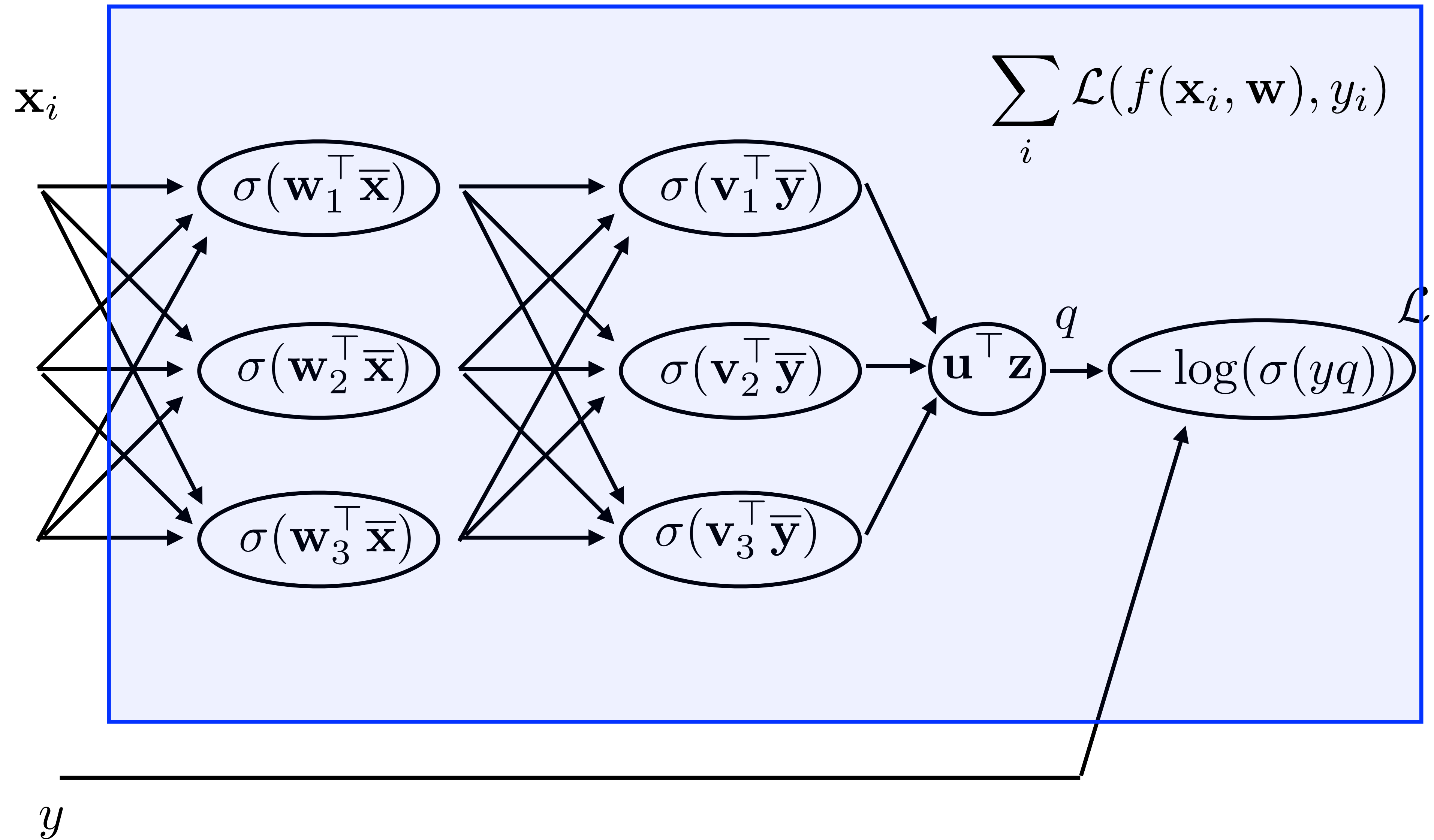

The Tungsten Electrode [Hubel-Science-1957]



<http://braintour.harvard.edu/archives/portfolio-items/hubel-and-wiesel>

- Device capable to record signal from a single neuron

[Hubel and Wiesel 1959]

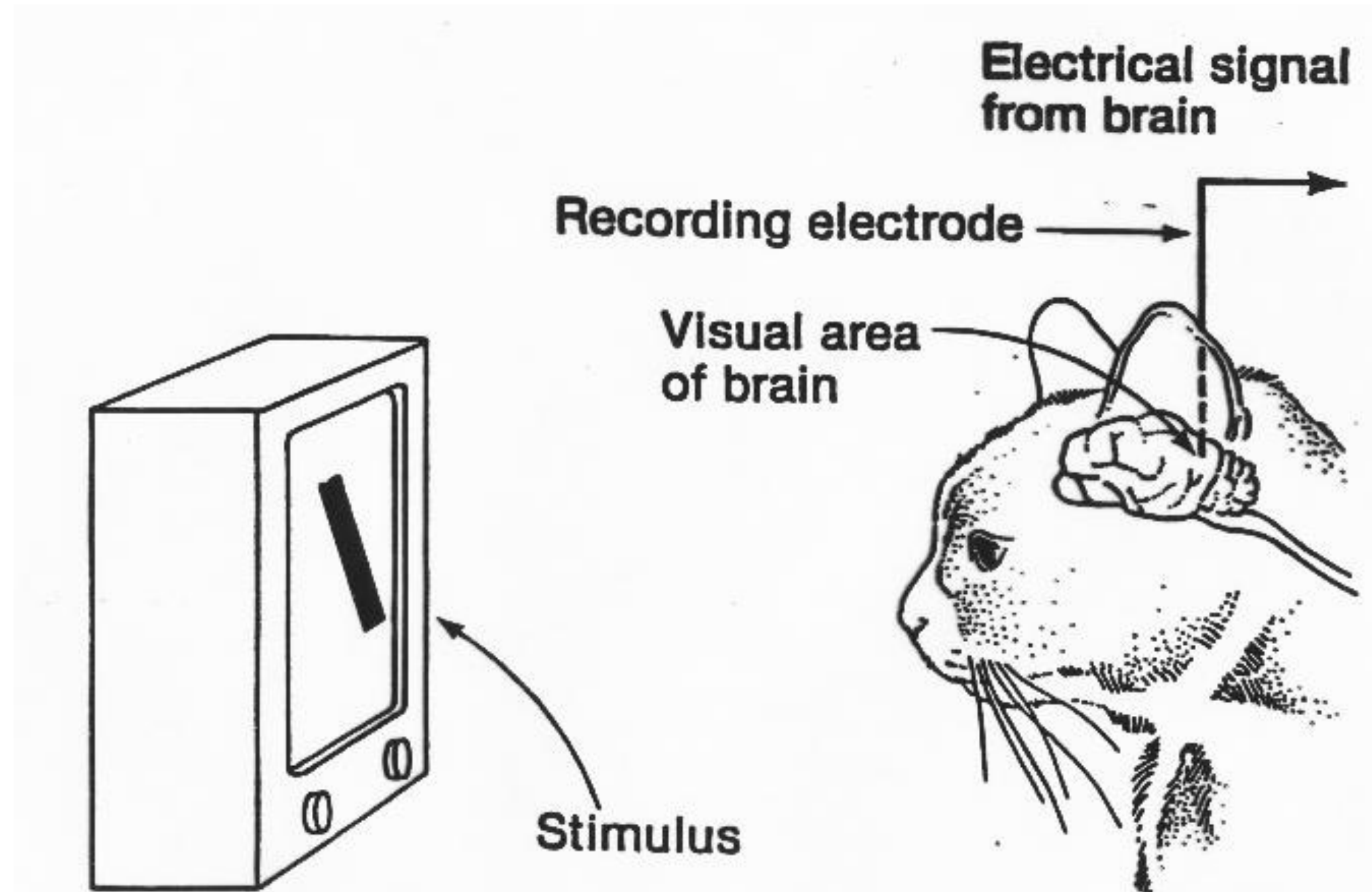

- Experiment with anaesthetised paralysed cat

[Hubel and Wiesel 1960]



- Edge sensitivity
- Topographical mapping
- Translation invariance

[Hubel and Wiesel 1960]

paralysed cat

awake monkey

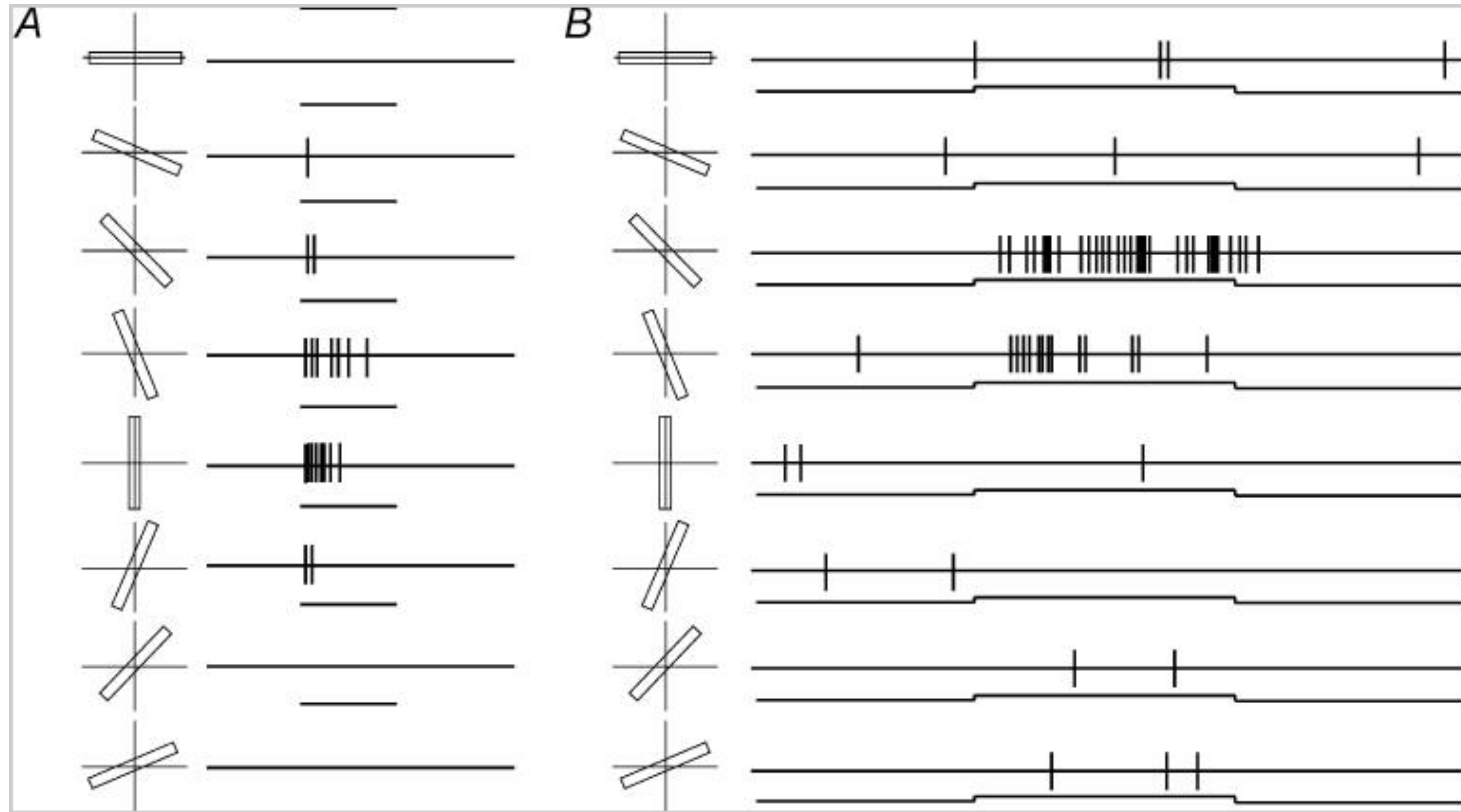

<https://knowingneurons.com/2014/10/29/hubel-and-wiesel-the-neural-basis-of-visual-perception/>

Hubel and Wiesel experiments in 1950s and 1960s



- Nobel Prize in Physiology and Medicine in 1981
- Dr. Hubel: “There has been a myth that the brain cannot understand itself. It is compared to a man trying to lift himself by his own bootstraps. We feel that is nonsense. The brain can be studied just as the kidney can.”

<https://knowingneurons.com/2014/10/29/hubel-and-wiesel-the-neural-basis-of-visual-perception/>

1. **Topographical map:** nearby neurons process information from nearby visual fields

image

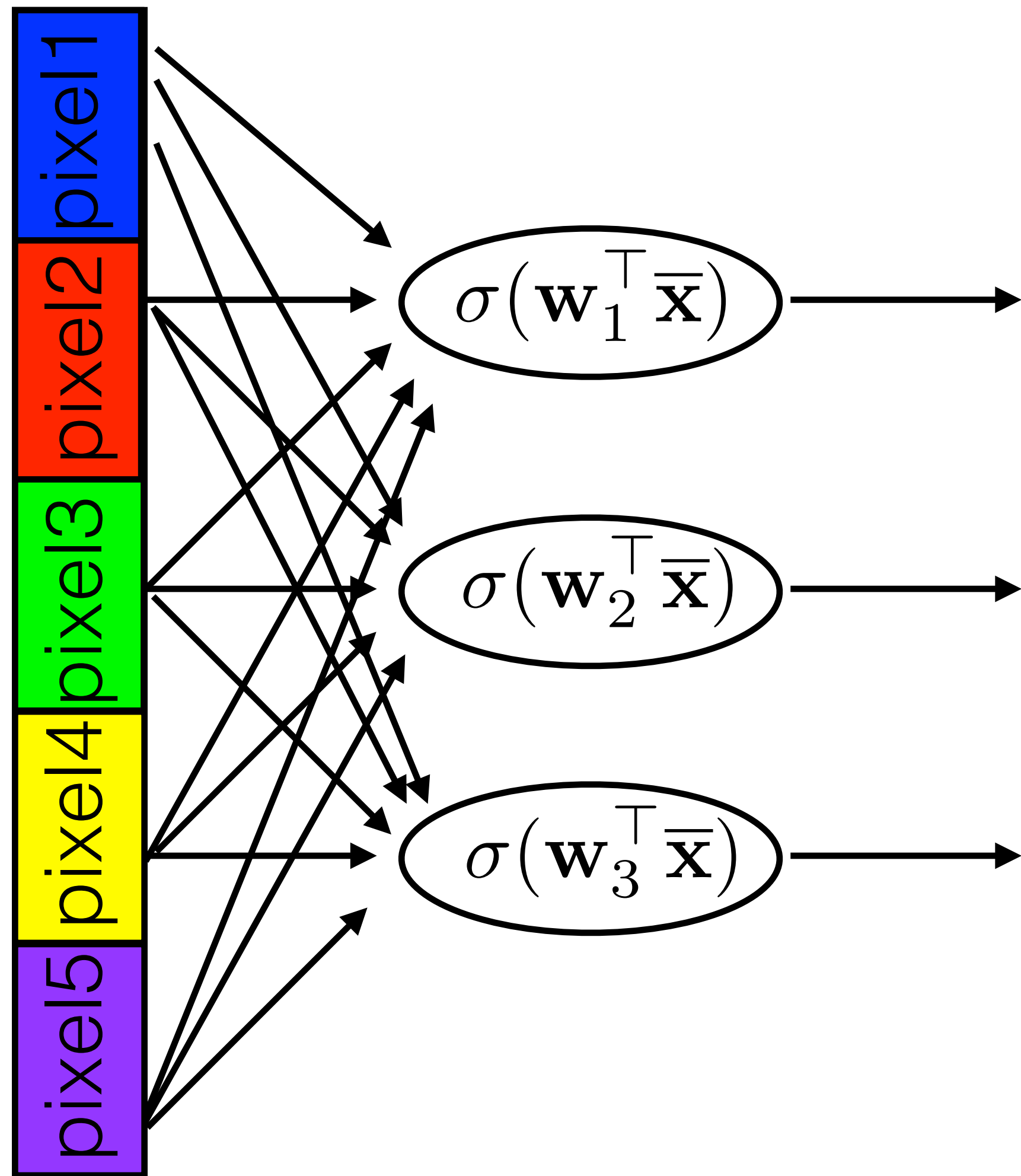

- Processing of visual information in cortex is not fully connected.

1. **Topographical map:** nearby neurons process information from nearby visual fields

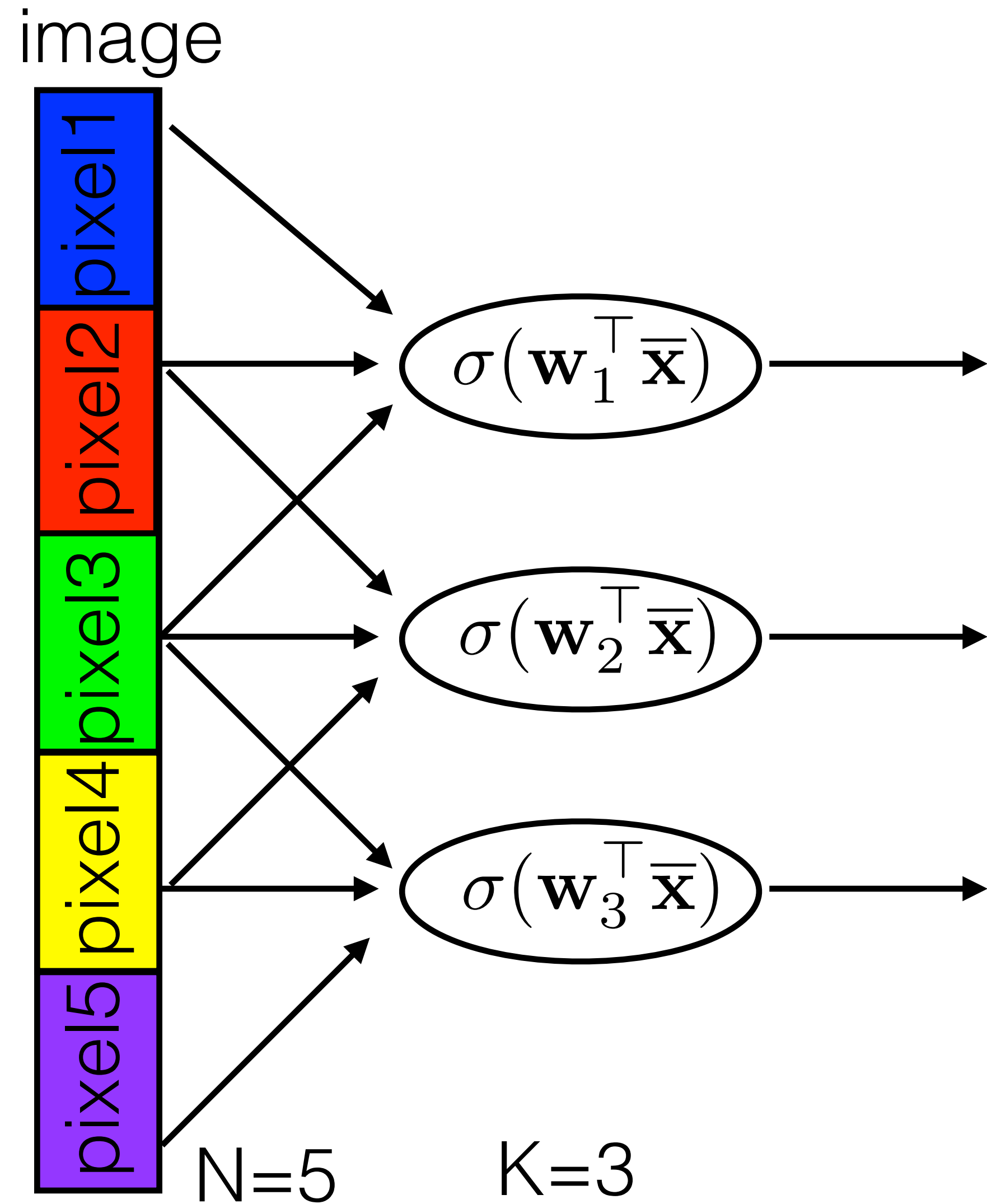

- What is the weight dimensionality reduction for N-pixel image and (n=3)-dimensional spatial neighbourhood?

2. **Translation invariance:** the same edge is detected at all positions

image

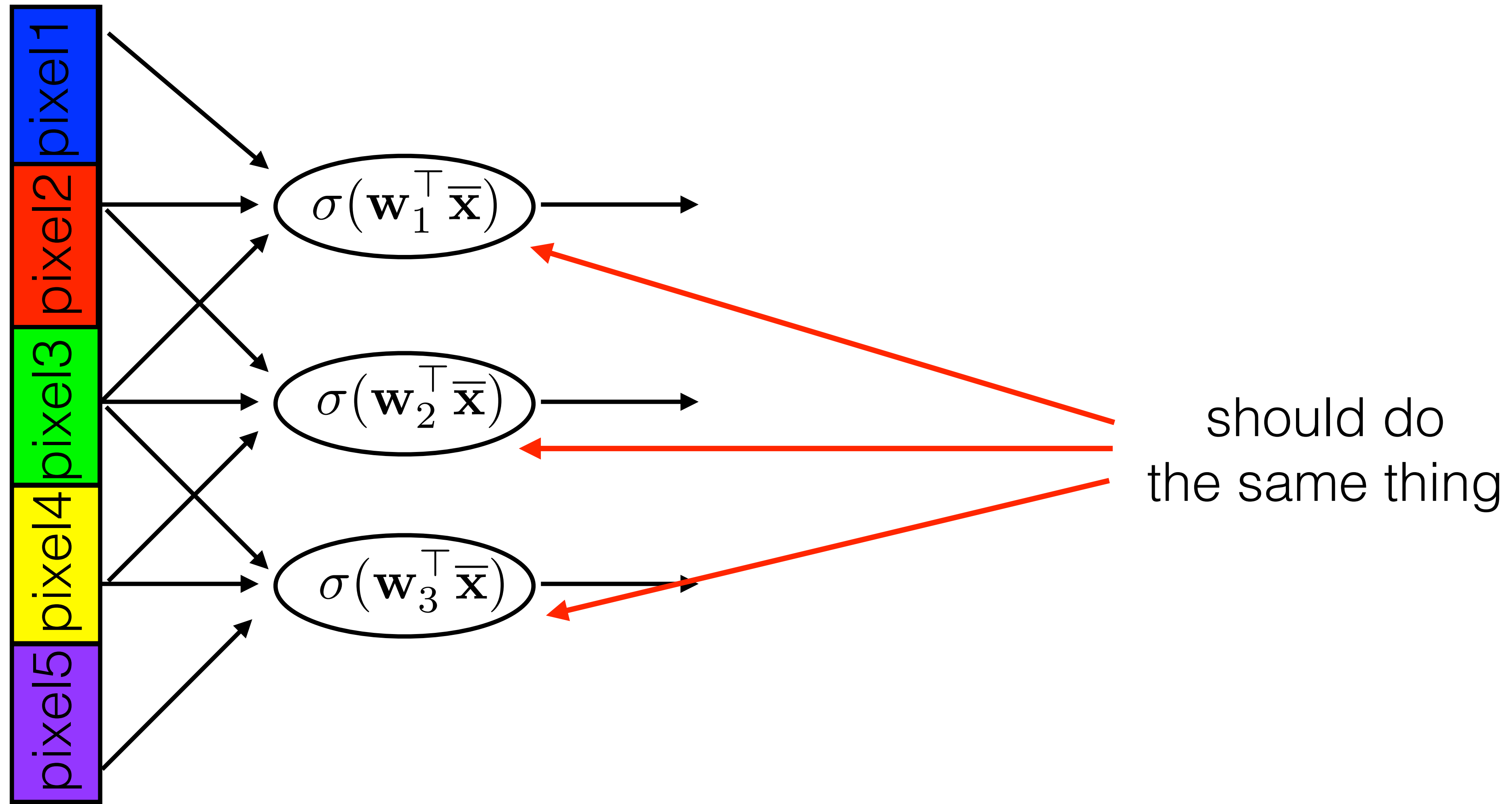

2. **Translation invariance:** the same edge is detected at all positions

image

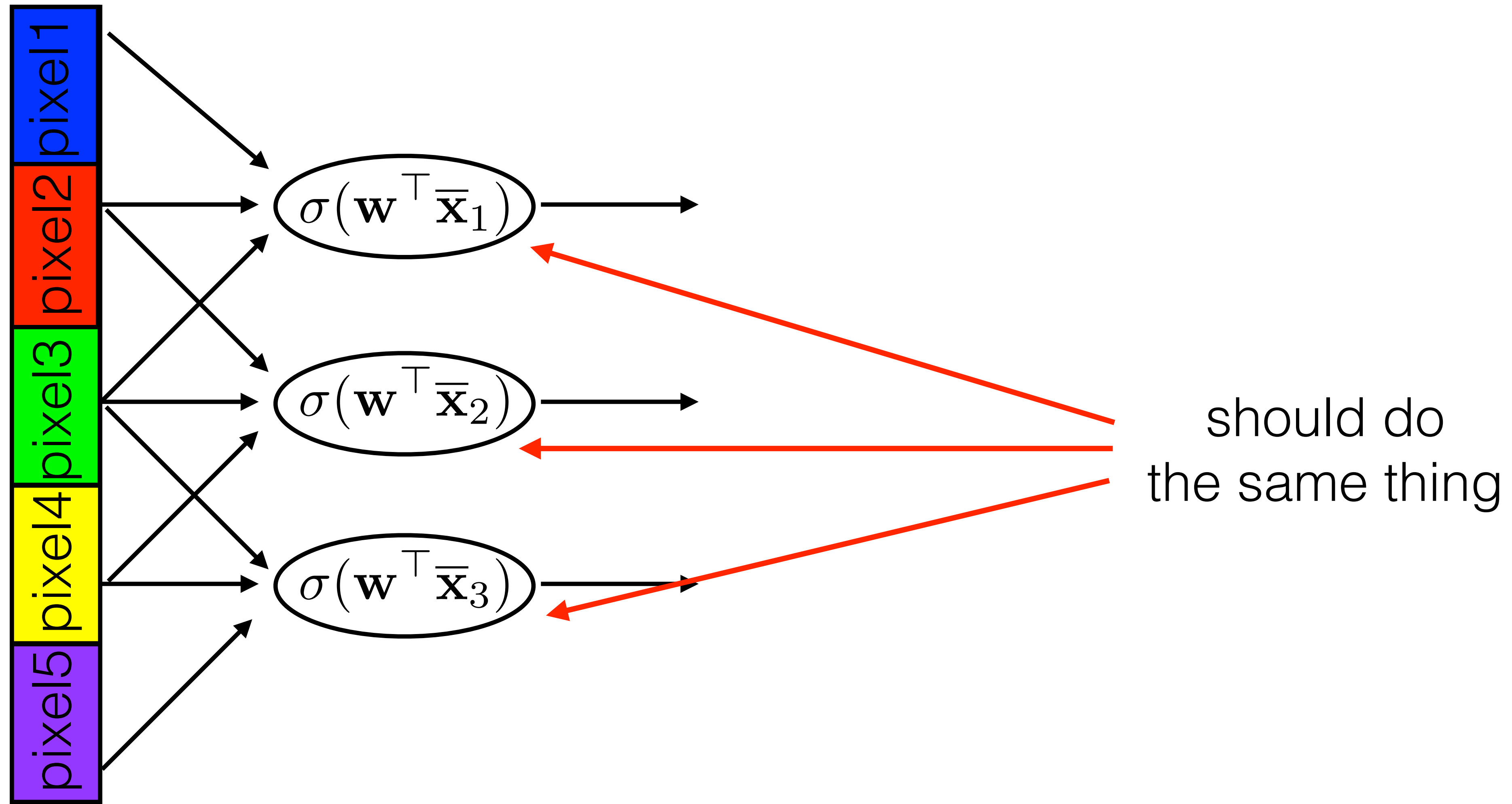

2. **Translation invariance:** the same edge is detected at all positions

image

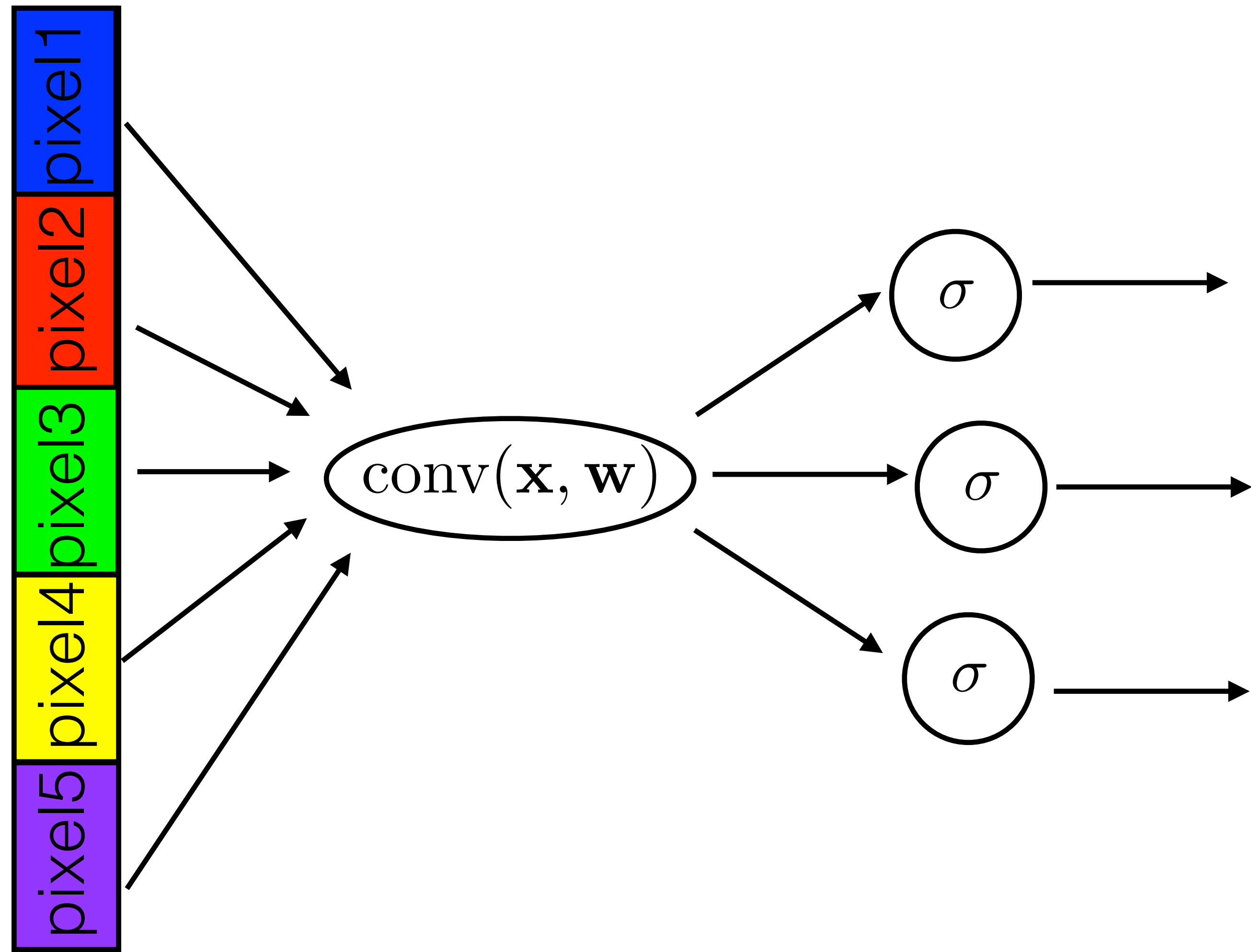

Convolution forward pass $\mathbf{y} = \text{conv}(\mathbf{x}, \mathbf{w})$

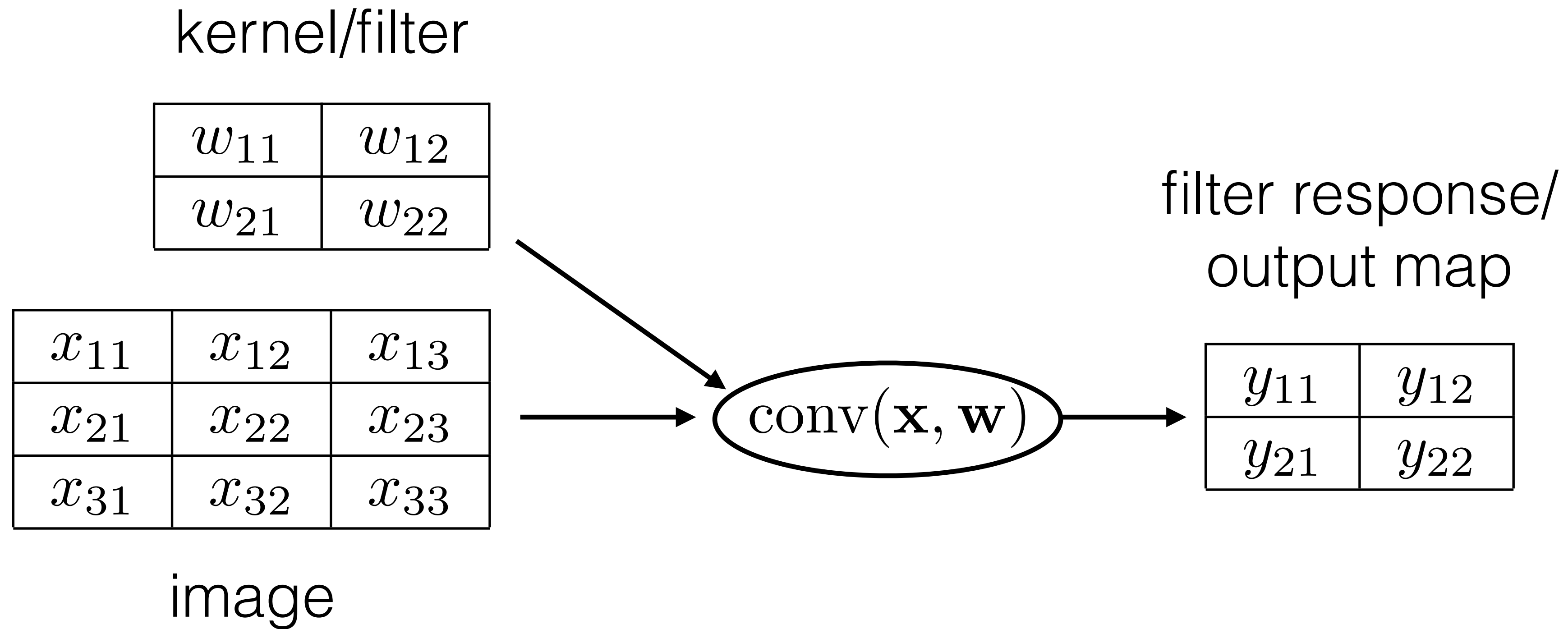

Convolution forward pass $\mathbf{y} = \text{conv}(\mathbf{x}, \mathbf{w})$

Local linear classifier run in double-for-loop over rows and columns

$$\begin{array}{|c|c|} \hline y_{11} & y_{12} \\ \hline y_{21} & y_{22} \\ \hline \end{array} = \text{conv} \left(\begin{array}{|c|c|c|} \hline x_{11} & x_{12} & x_{13} \\ \hline x_{21} & x_{22} & x_{23} \\ \hline x_{31} & x_{32} & x_{33} \\ \hline \end{array}, \begin{array}{|c|c|} \hline w_{11} & w_{12} \\ \hline w_{21} & w_{22} \\ \hline \end{array} \right)$$

$$y_{11} = w_{11}x_{11} + w_{12}x_{12} + w_{21}x_{21} + w_{22}x_{22}$$

$$y_{12} = w_{11}x_{12} + w_{12}x_{13} + w_{21}x_{22} + w_{22}x_{23}$$

$$y_{21} = w_{11}x_{21} + w_{12}x_{22} + w_{21}x_{31} + w_{22}x_{32}$$

$$y_{22} = w_{11}x_{22} + w_{12}x_{23} + w_{21}x_{32} + w_{22}x_{33}$$

Convolution forward pass $\mathbf{y} = \text{conv}(\mathbf{x}, \mathbf{w})$

$$\begin{array}{|c|c|} \hline y_{11} & y_{12} \\ \hline y_{21} & y_{22} \\ \hline \end{array} = \text{conv} \left(\begin{array}{|c|c|c|} \hline x_{11} & x_{12} & x_{13} \\ \hline x_{21} & x_{22} & x_{23} \\ \hline x_{31} & x_{32} & x_{33} \\ \hline \end{array}, \begin{array}{|c|c|} \hline w_{11} & w_{12} \\ \hline w_{21} & w_{22} \\ \hline \end{array} \right)$$

$$y_{11} = w_{11}x_{11} + w_{12}x_{12} + w_{21}x_{21} + w_{22}x_{22}$$

$$y_{12} = w_{11}x_{12} + w_{12}x_{13} + w_{21}x_{22} + w_{22}x_{23}$$

$$y_{21} = w_{11}x_{21} + w_{12}x_{22} + w_{21}x_{31} + w_{22}x_{32}$$

$$y_{22} = w_{11}x_{22} + w_{12}x_{23} + w_{21}x_{32} + w_{22}x_{33}$$

Convolution forward pass $\mathbf{y} = \text{conv}(\mathbf{x}, \mathbf{w})$

$$\begin{array}{|c|c|} \hline y_{11} & y_{12} \\ \hline y_{21} & y_{22} \\ \hline \end{array} = \text{conv} \left(\begin{array}{|c|c|c|} \hline x_{11} & x_{12} & x_{13} \\ \hline x_{21} & x_{22} & x_{23} \\ \hline x_{31} & x_{32} & x_{33} \\ \hline \end{array}, \begin{array}{|c|c|} \hline w_{11} & w_{12} \\ \hline w_{21} & w_{22} \\ \hline \end{array} \right)$$

$$y_{11} = w_{11}x_{11} + w_{12}x_{12} + w_{21}x_{21} + w_{22}x_{22}$$

$$y_{12} = w_{11}x_{12} + w_{12}x_{13} + w_{21}x_{22} + w_{22}x_{23}$$

$$y_{21} = w_{11}x_{21} + w_{12}x_{22} + w_{21}x_{31} + w_{22}x_{32}$$

$$y_{22} = w_{11}x_{22} + w_{12}x_{23} + w_{21}x_{32} + w_{22}x_{33}$$

Convolution forward pass $\mathbf{y} = \text{conv}(\mathbf{x}, \mathbf{w})$

$$\begin{array}{|c|c|} \hline y_{11} & y_{12} \\ \hline y_{21} & y_{22} \\ \hline \end{array} = \text{conv} \left(\begin{array}{|c|c|c|} \hline x_{11} & x_{12} & x_{13} \\ \hline x_{21} & x_{22} & x_{23} \\ \hline x_{31} & x_{32} & x_{33} \\ \hline \end{array}, \begin{array}{|c|c|} \hline w_{11} & w_{12} \\ \hline w_{21} & w_{22} \\ \hline \end{array} \right)$$

$$y_{11} = w_{11}x_{11} + w_{12}x_{12} + w_{21}x_{21} + w_{22}x_{22}$$

$$y_{12} = w_{11}x_{12} + w_{12}x_{13} + w_{21}x_{22} + w_{22}x_{23}$$

$$y_{21} = w_{11}x_{21} + w_{12}x_{22} + w_{21}x_{31} + w_{22}x_{32}$$

$$y_{22} = w_{11}x_{22} + w_{12}x_{23} + w_{21}x_{32} + w_{22}x_{33}$$

Convolution forward pass $\mathbf{y} = \text{conv}(\mathbf{x}, \mathbf{w})$

$$\begin{array}{|c|c|} \hline y_{11} & y_{12} \\ \hline y_{21} & y_{22} \\ \hline \end{array} = \text{conv} \left(\begin{array}{|c|c|c|} \hline x_{11} & x_{12} & x_{13} \\ \hline x_{21} & x_{22} & x_{23} \\ \hline x_{31} & x_{32} & x_{33} \\ \hline \end{array}, \begin{array}{|c|c|} \hline w_{11} & w_{12} \\ \hline w_{21} & w_{22} \\ \hline \end{array} \right)$$

$$y_{11} = w_{11}x_{11} + w_{12}x_{12} + w_{21}x_{21} + w_{22}x_{22}$$

$$y_{12} = w_{11}x_{12} + w_{12}x_{13} + w_{21}x_{22} + w_{22}x_{23}$$

$$y_{21} = w_{11}x_{21} + w_{12}x_{22} + w_{21}x_{31} + w_{22}x_{32}$$

$$y_{22} = w_{11}x_{22} + w_{12}x_{23} + w_{21}x_{32} + w_{22}x_{33}$$

Feature maps

Local linear classifier run in double-for-loop over rows and columns

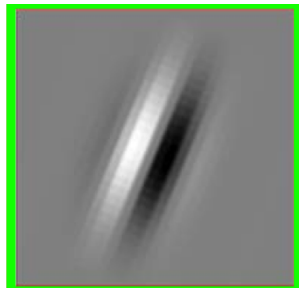

Convolutional kernel 1



Image

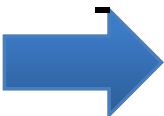

Feature map 1

Feature maps

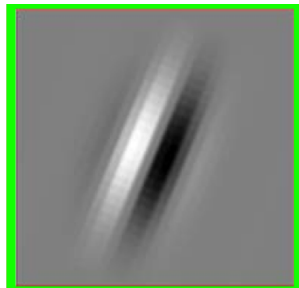

Convolutional kernel 1

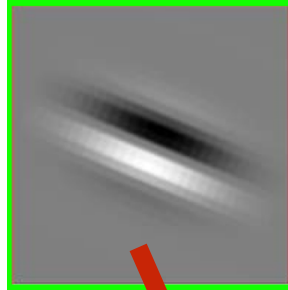

Convolutional kernel 2



Image

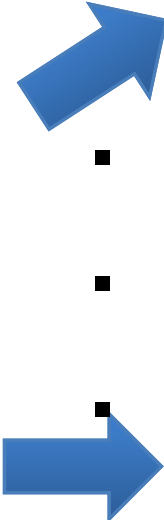

Feature map 2



Feature map 1

Convolution layer properties - output size

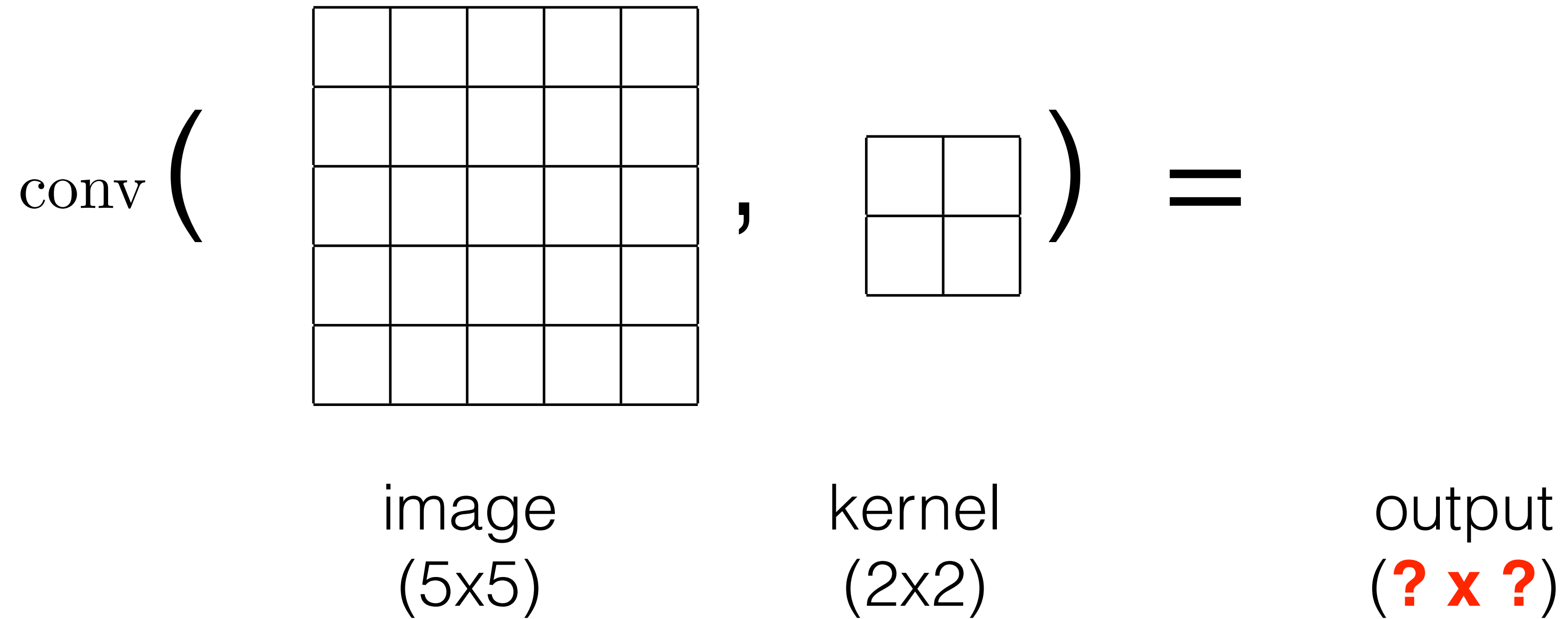

Convolution layer properties - output size

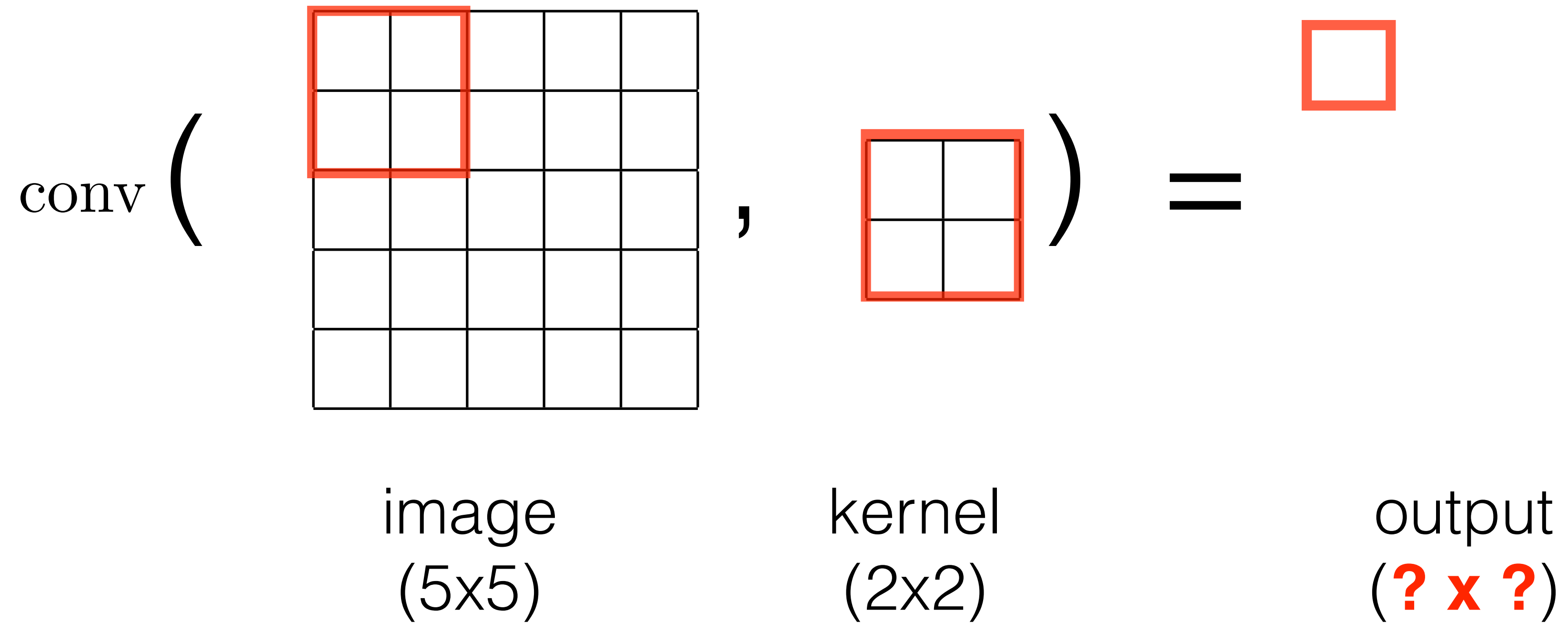

Convolution layer properties - output size

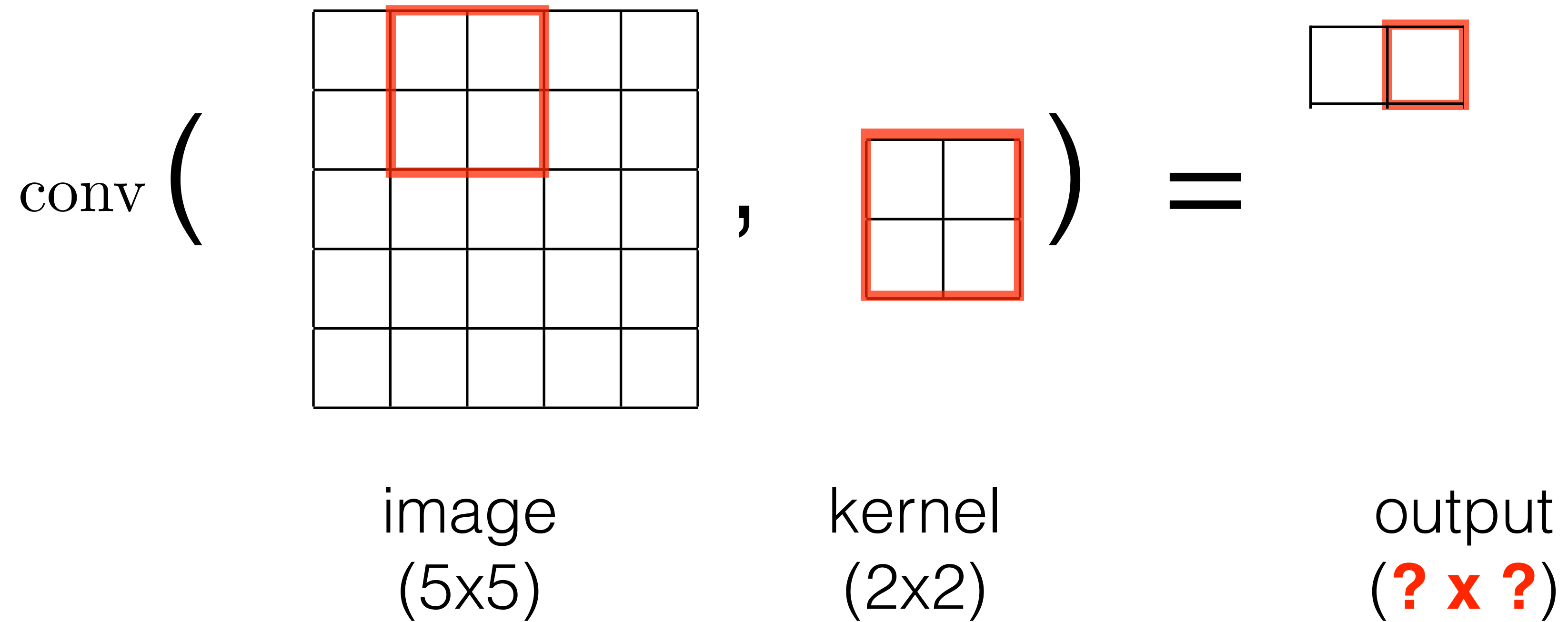

Convolution layer properties - output size

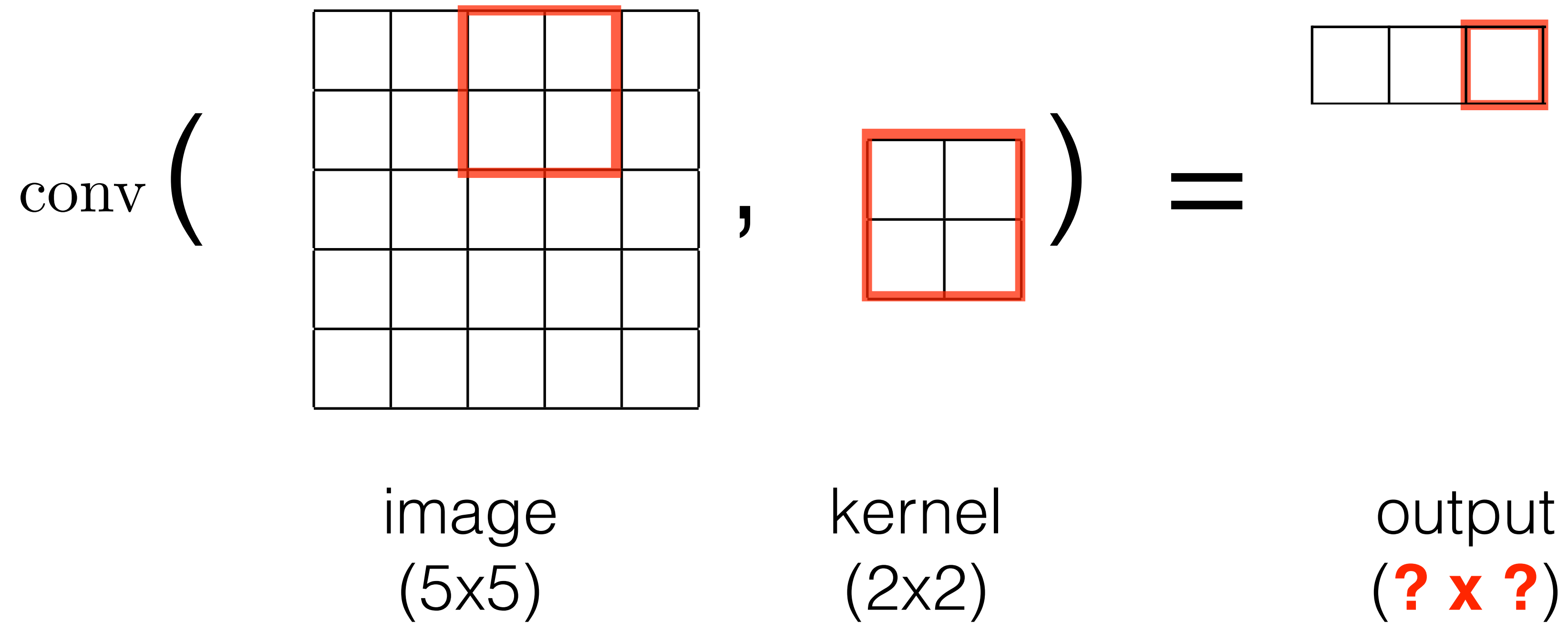

Convolution layer properties - output size

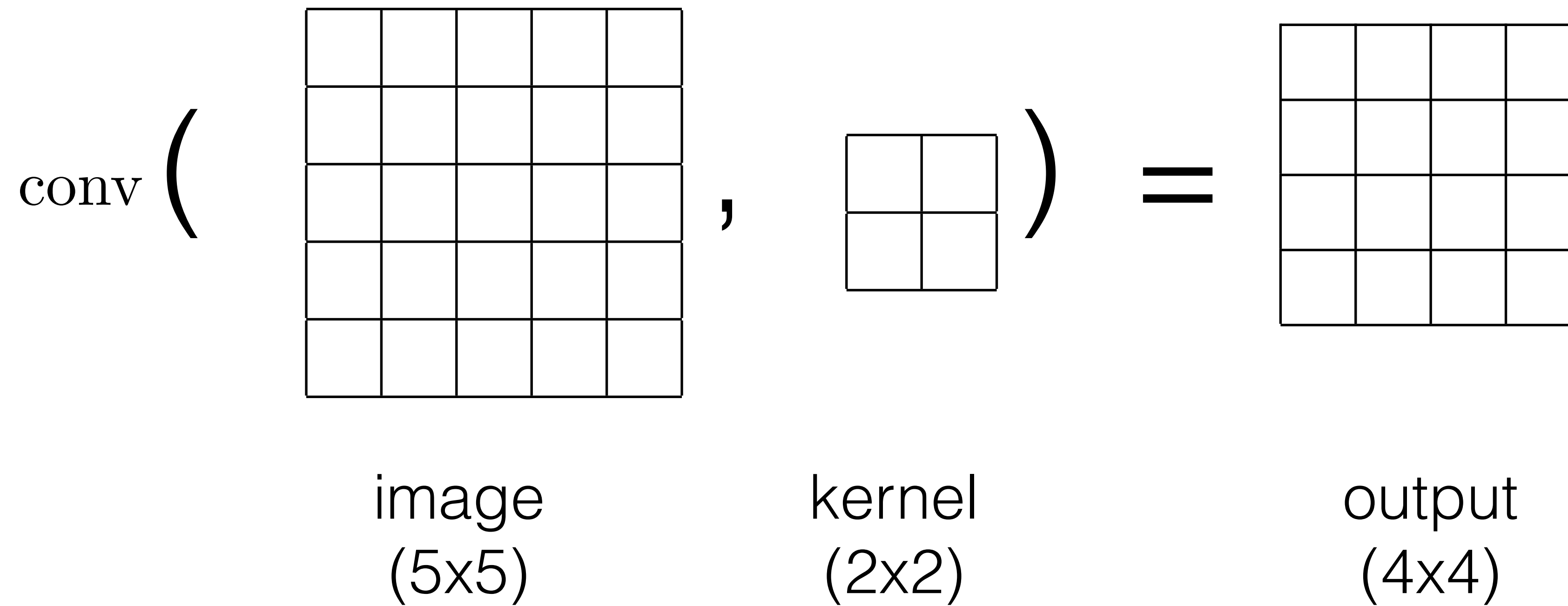

Convolution layer properties - output size

$$M = N - K + 1$$

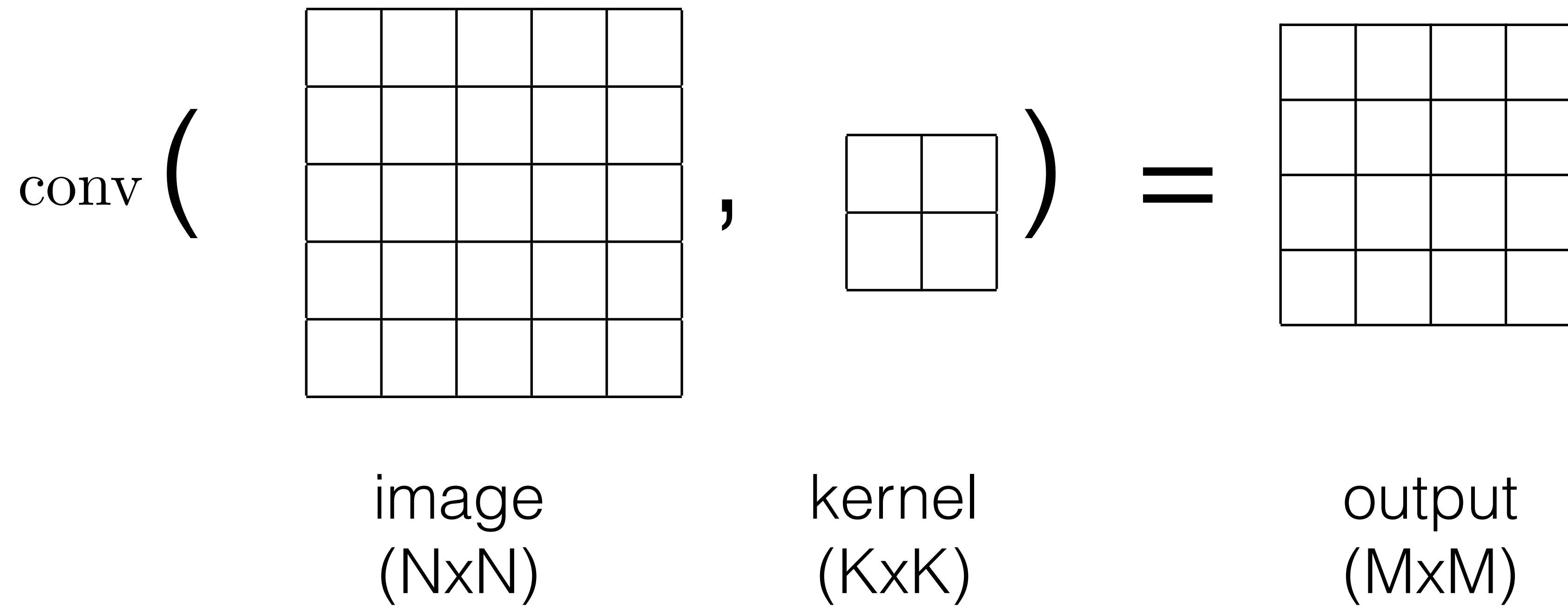

Convolution layer properties - stride

stride = 1

kernel moves by 1 pixel

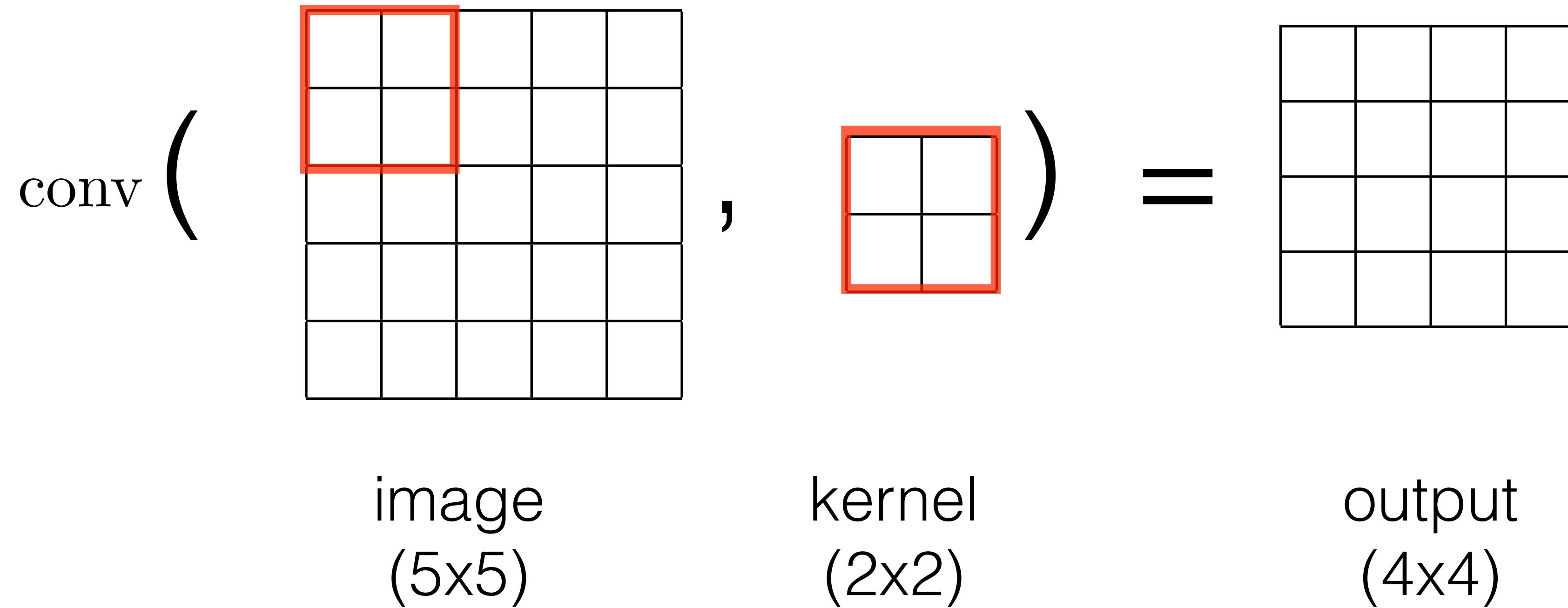

Convolution layer properties - stride

stride = 3

kernel moves by 3 pixels

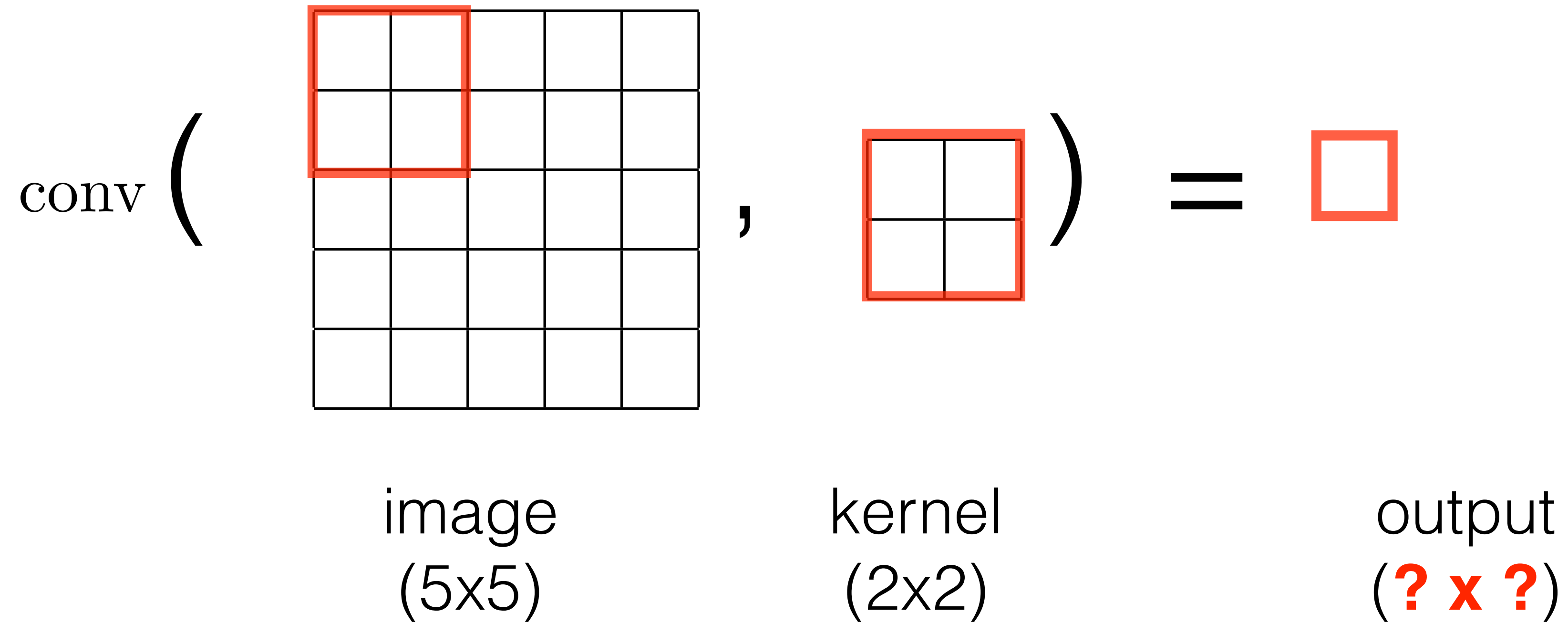

Convolution layer properties - stride

stride = 3

kernel moves by 3 pixels

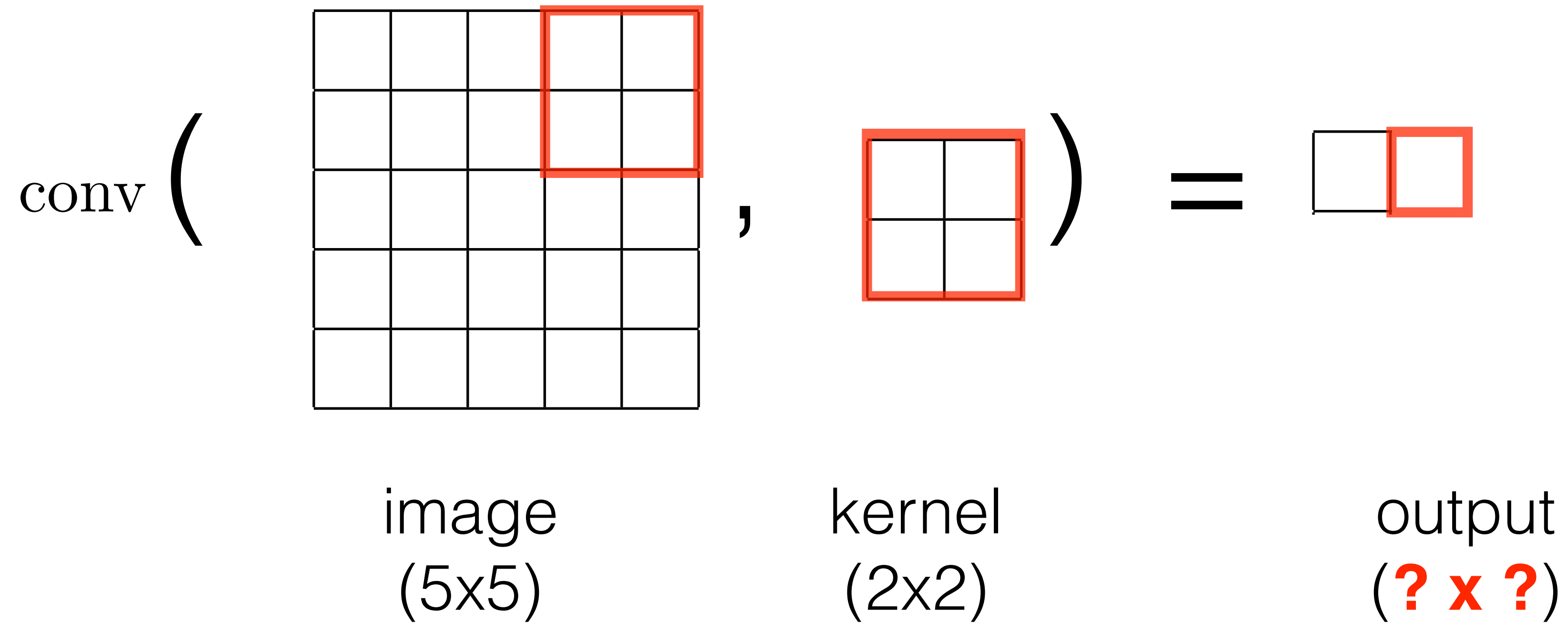
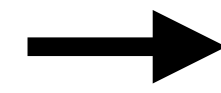

Convolution layer properties - stride

stride = 3

kernel moves by 3 pixels

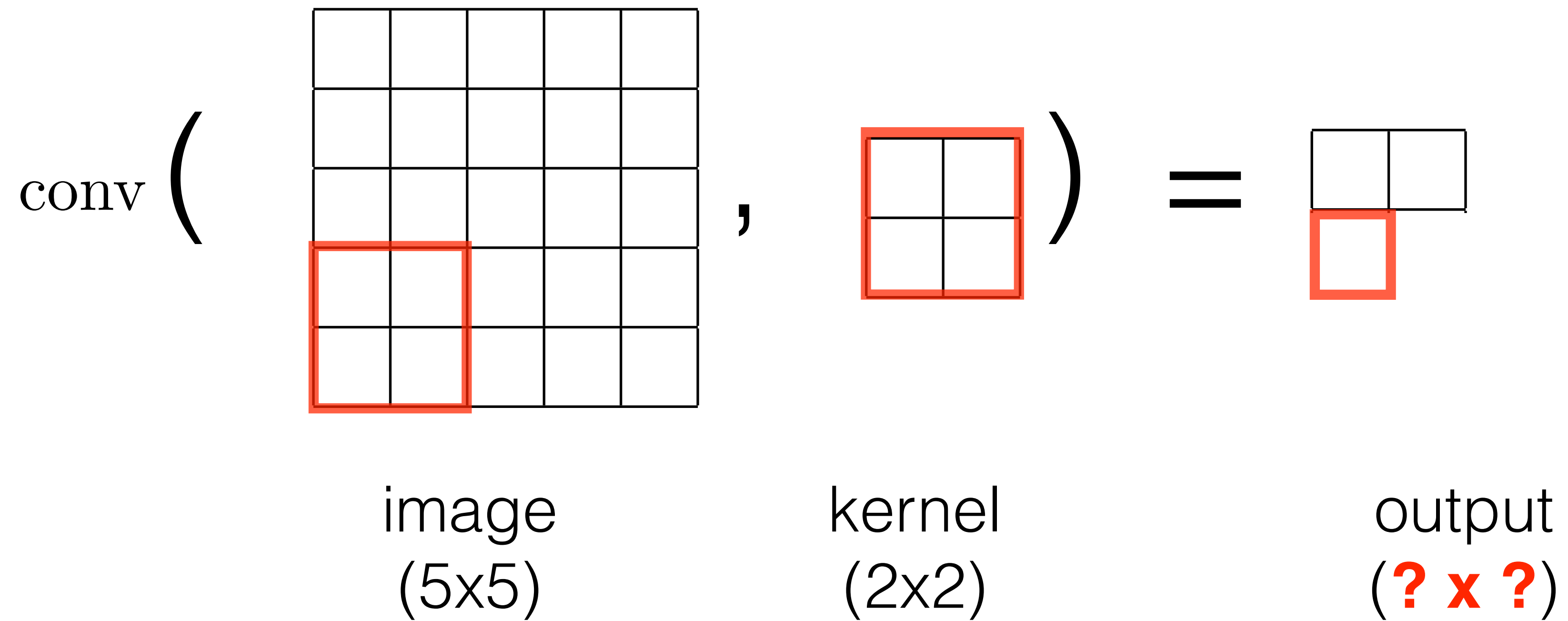

Convolution layer properties - stride

stride = 3

kernel moves by 3 pixels

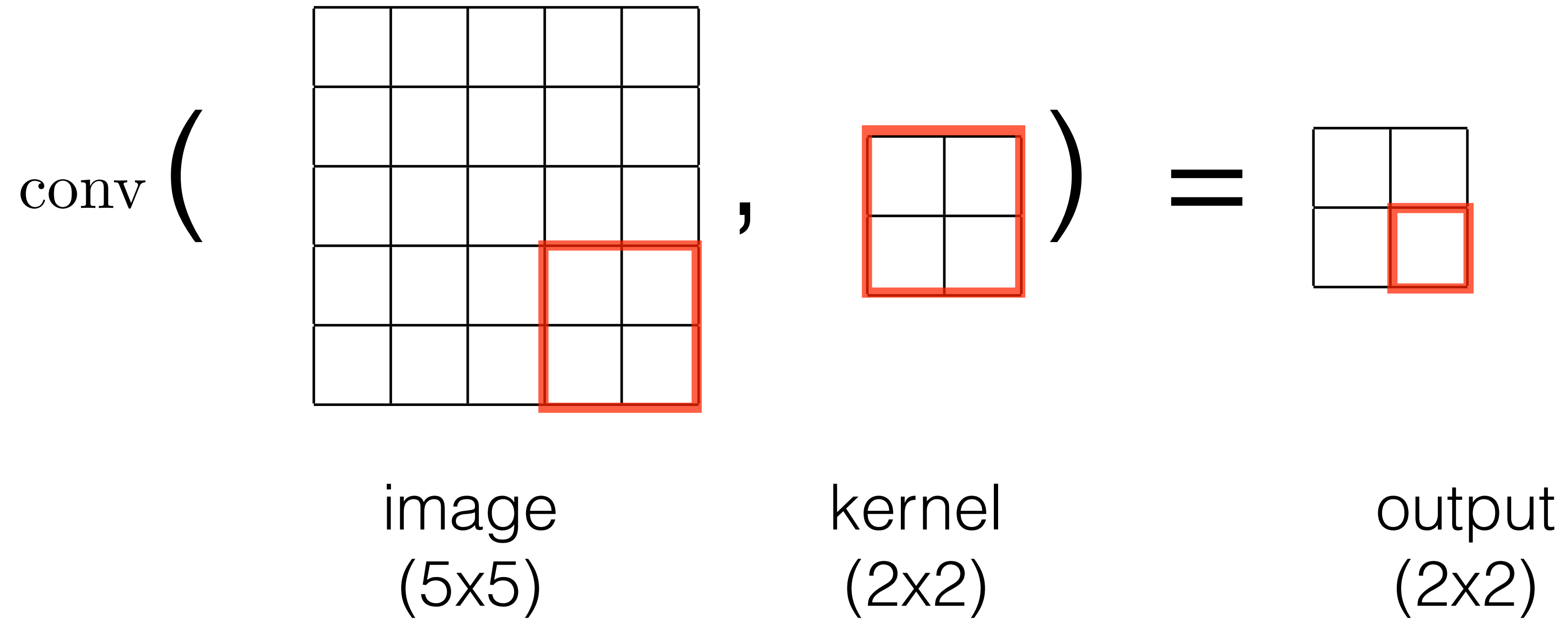

Convolution layer properties - stride

$$M = \text{floor}((N-K) / \text{stride} + 1)$$

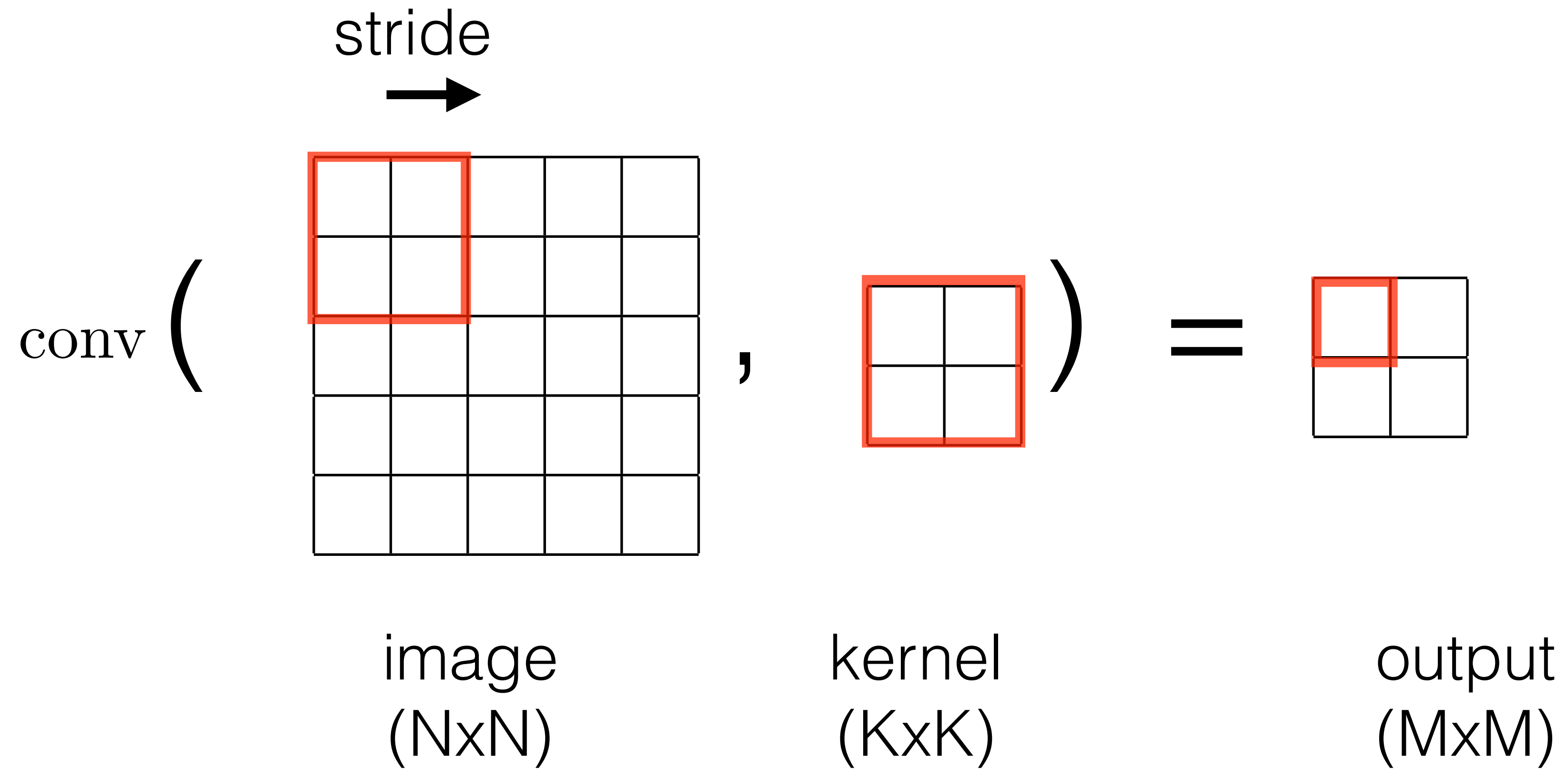

e.g. $M = (5-2) / 3 + 1 = 2$

Convolution layer properties - pad

pad = 1

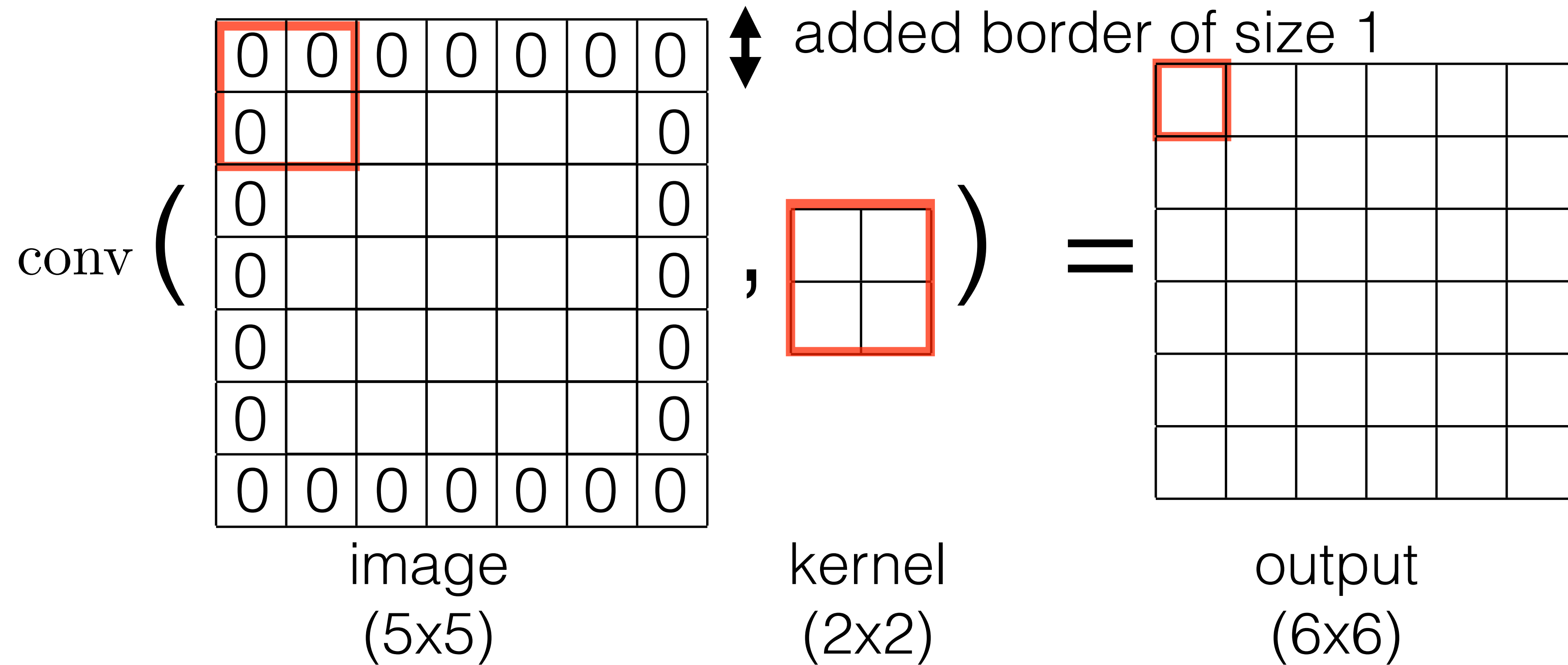

Convolution layer properties - pad

$$M = \text{floor}((N+2*\text{pad}-K) / \text{stride} + 1)$$

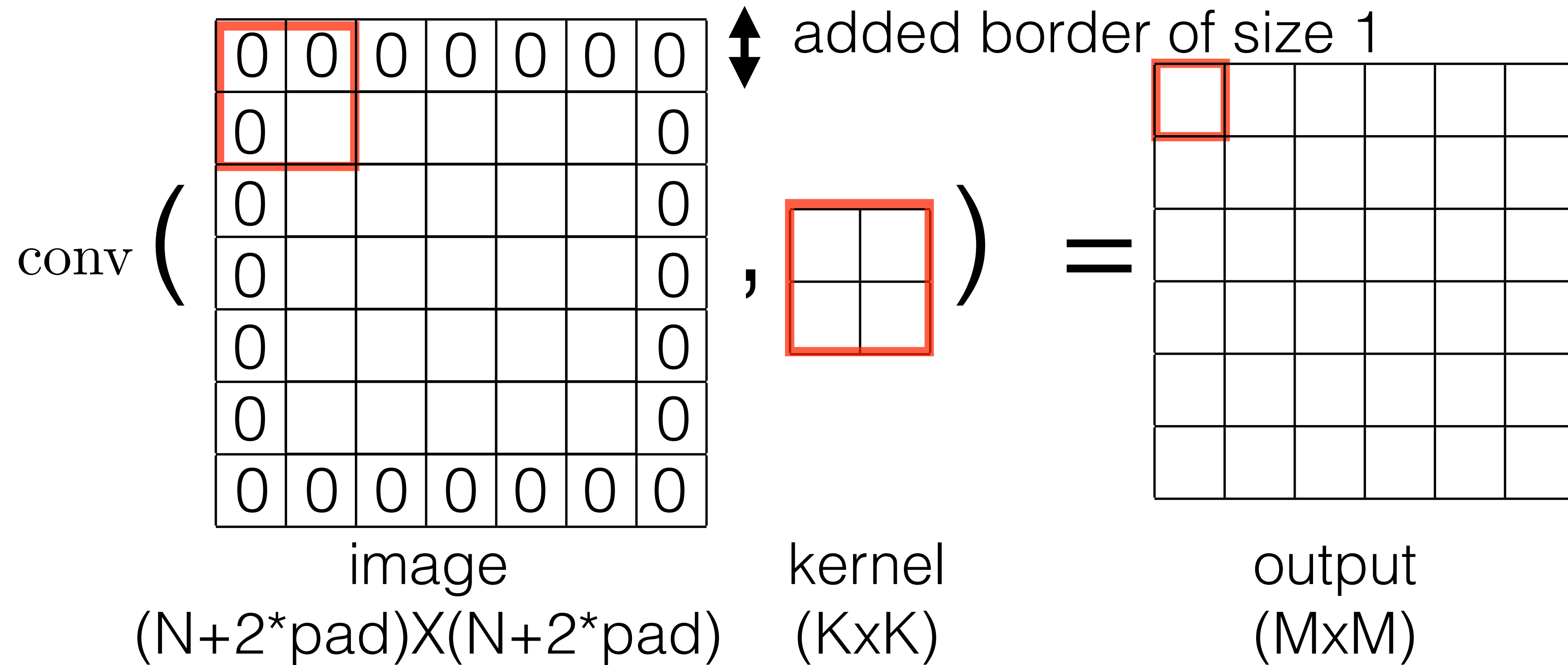

Convolution layer

Dilatation rate = 1

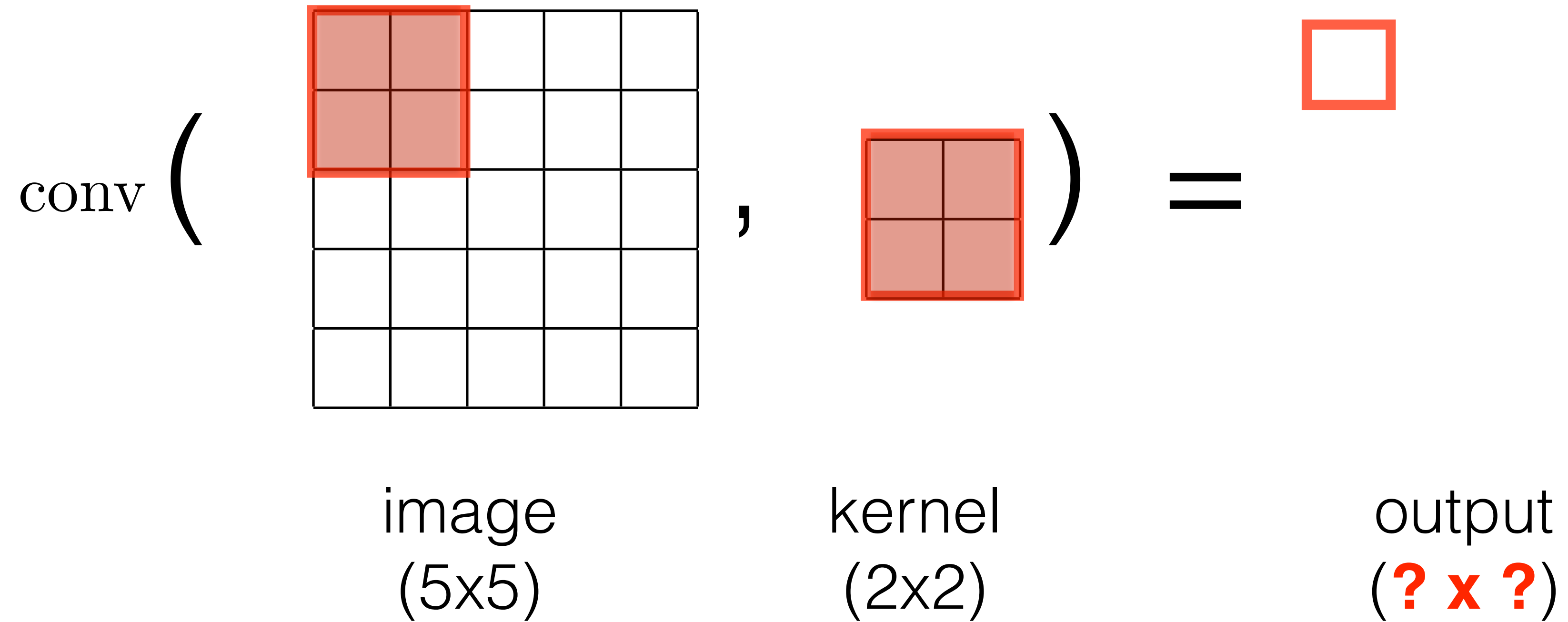

Atrous convolution layer

Dilatation rate = 2

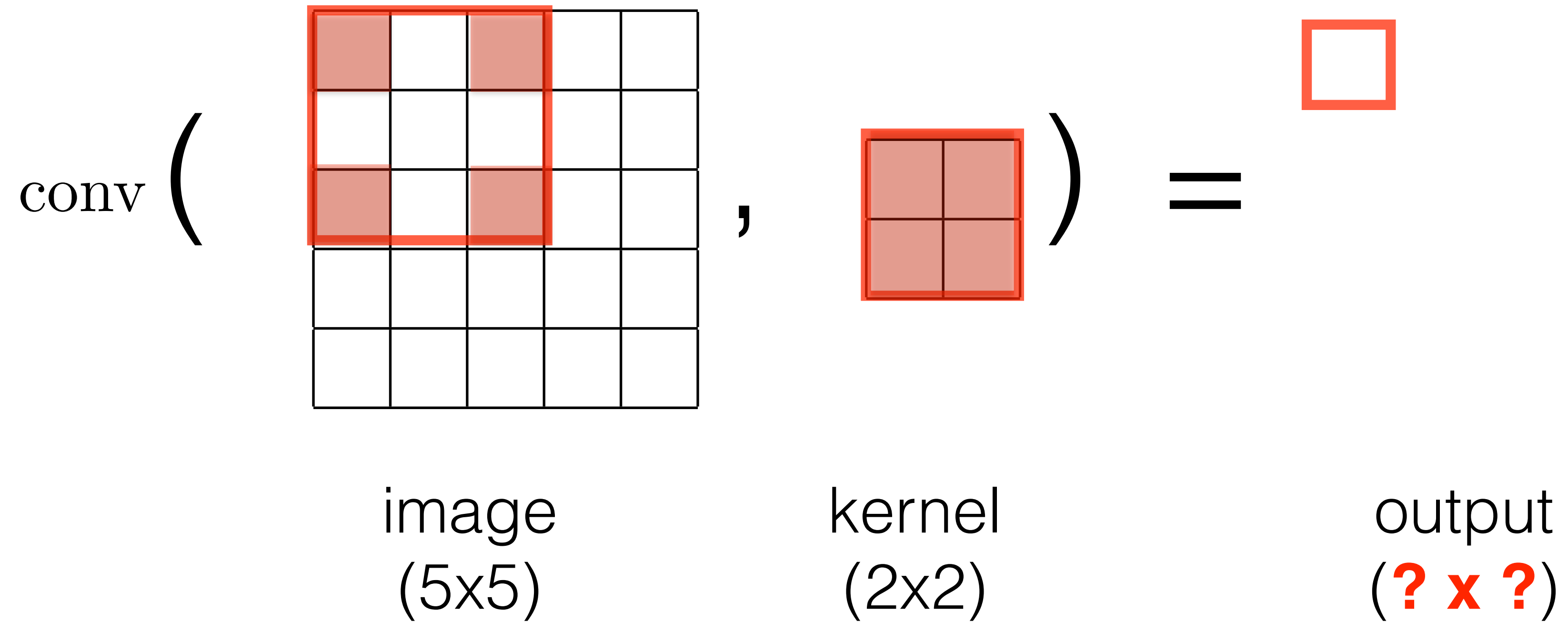

Show python code

Multi-channel convolution

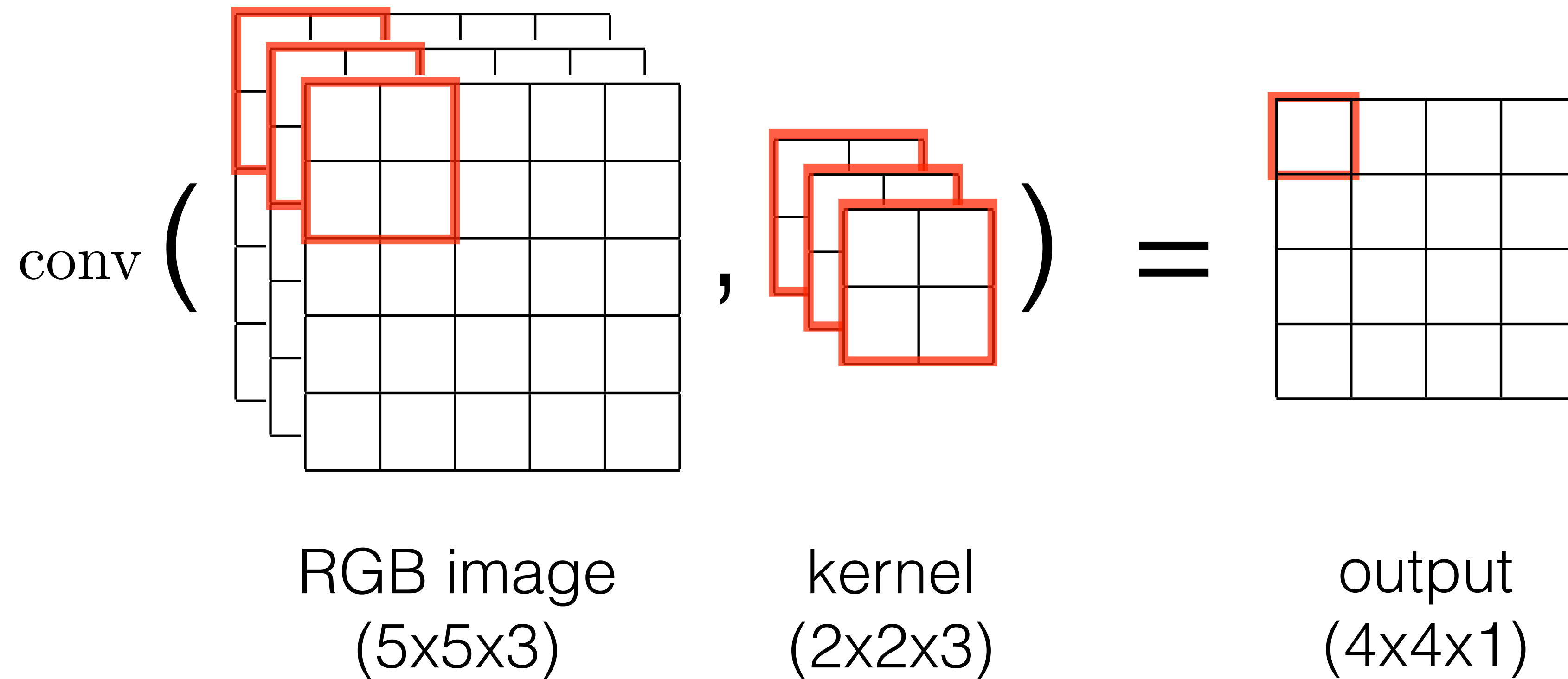

Multi-channel convolution

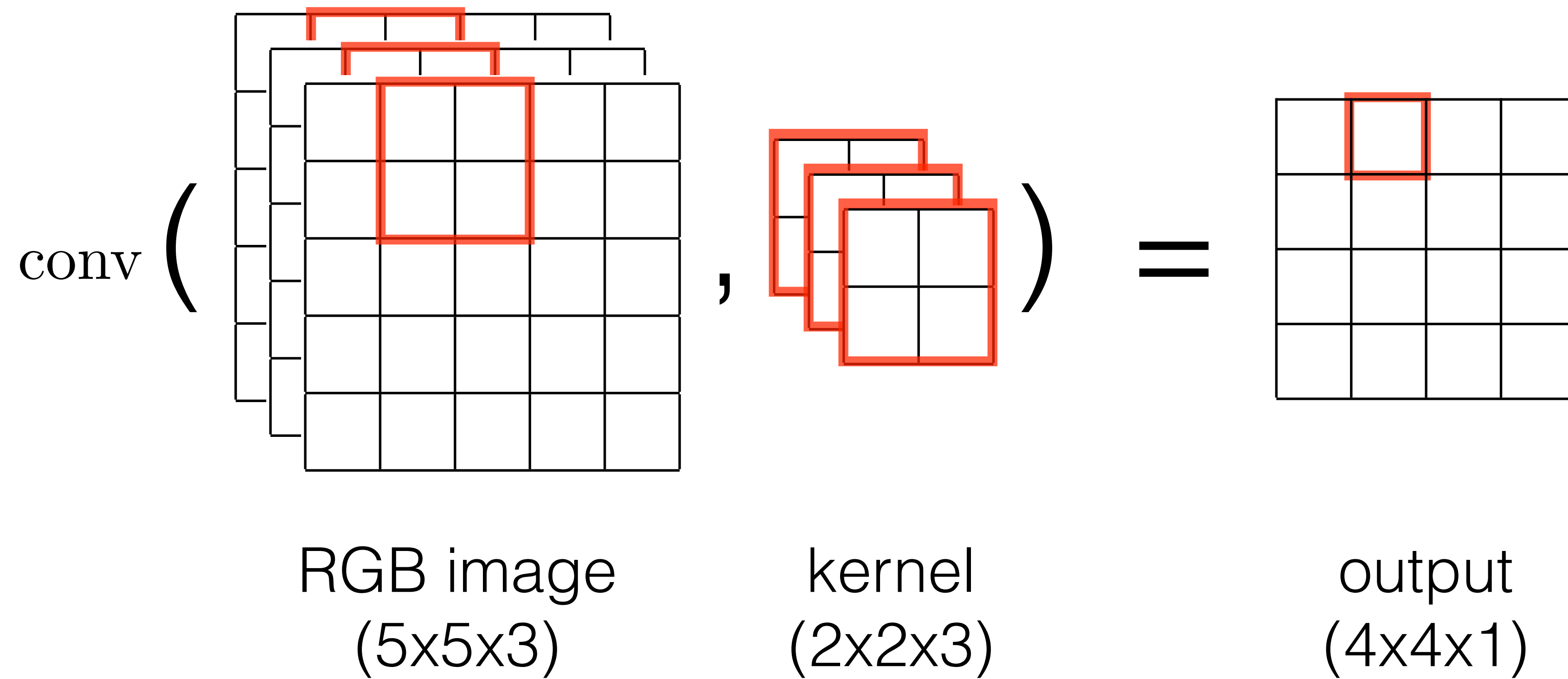

Multi-channel convolution

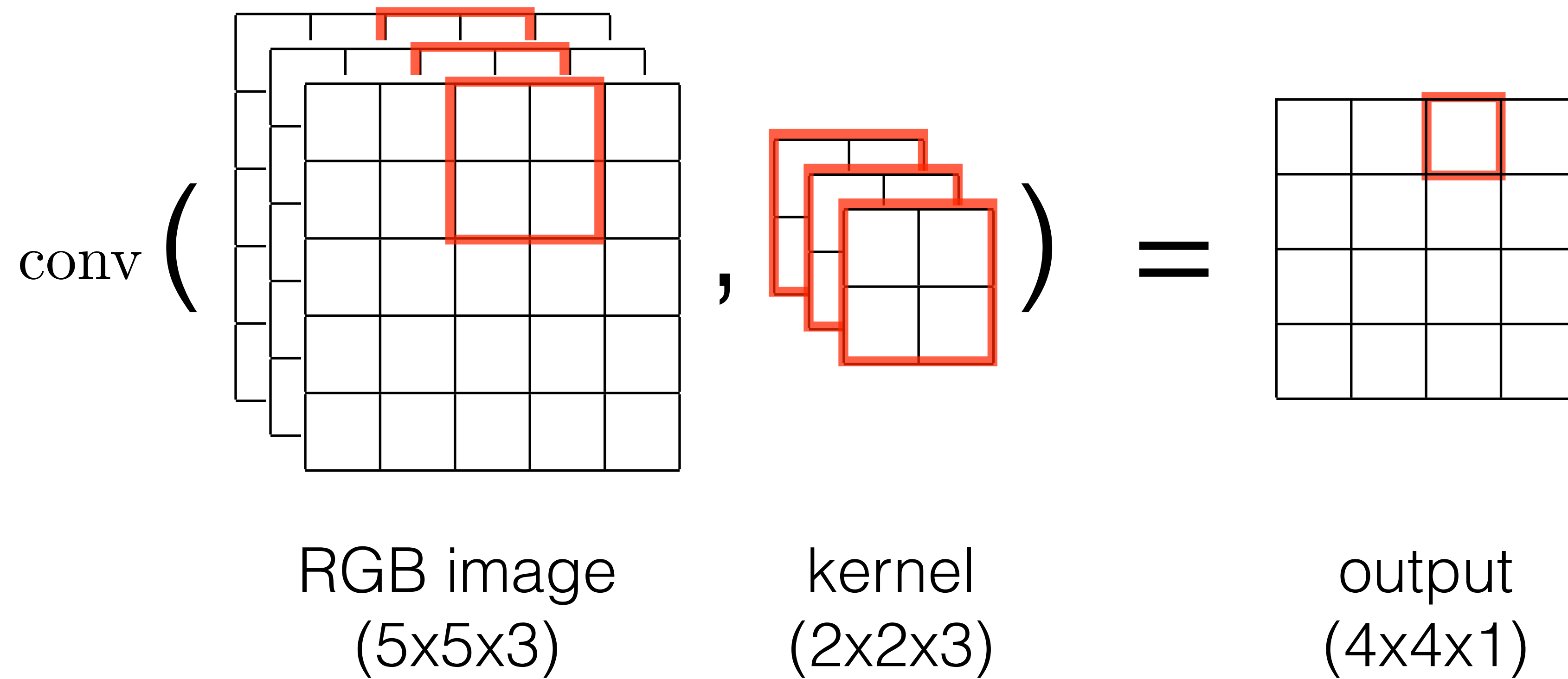

Multi-channel convolution

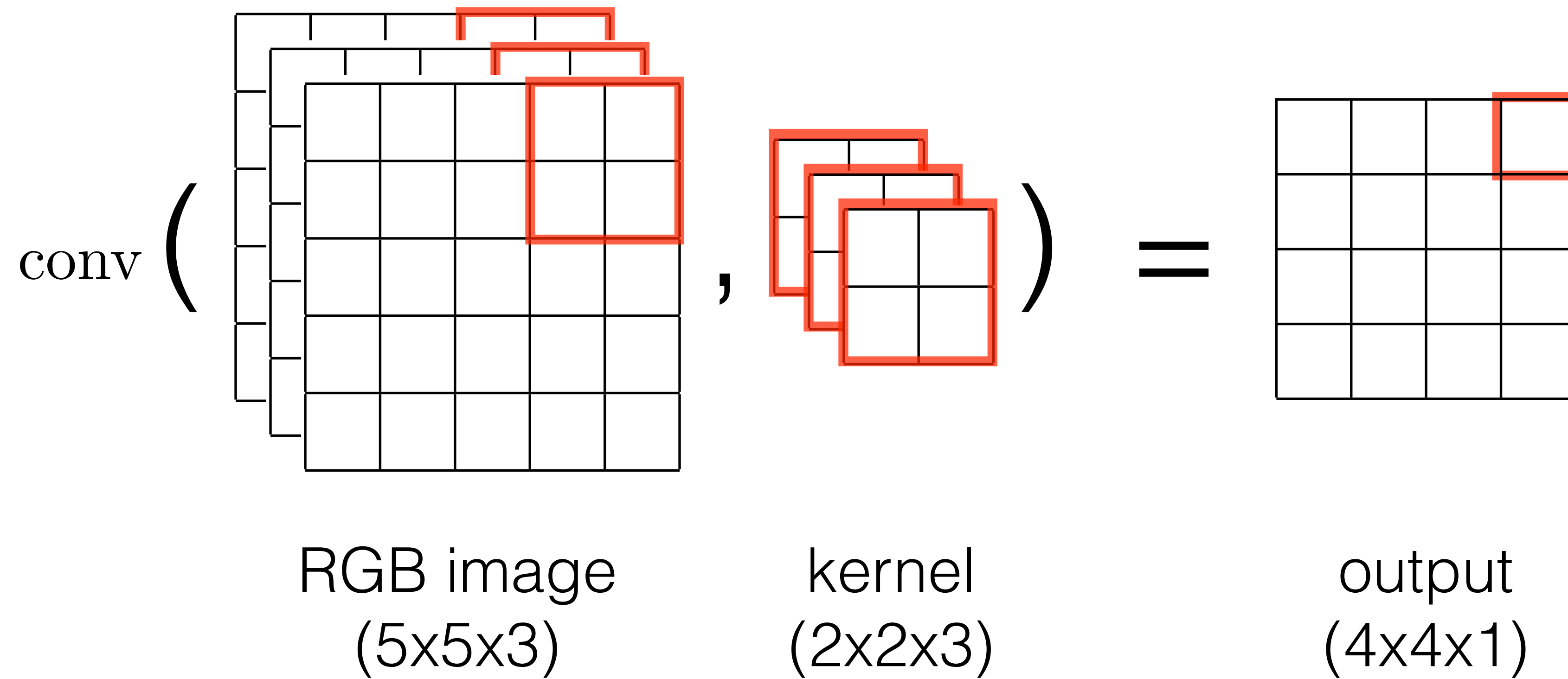

Multi-channel convolution

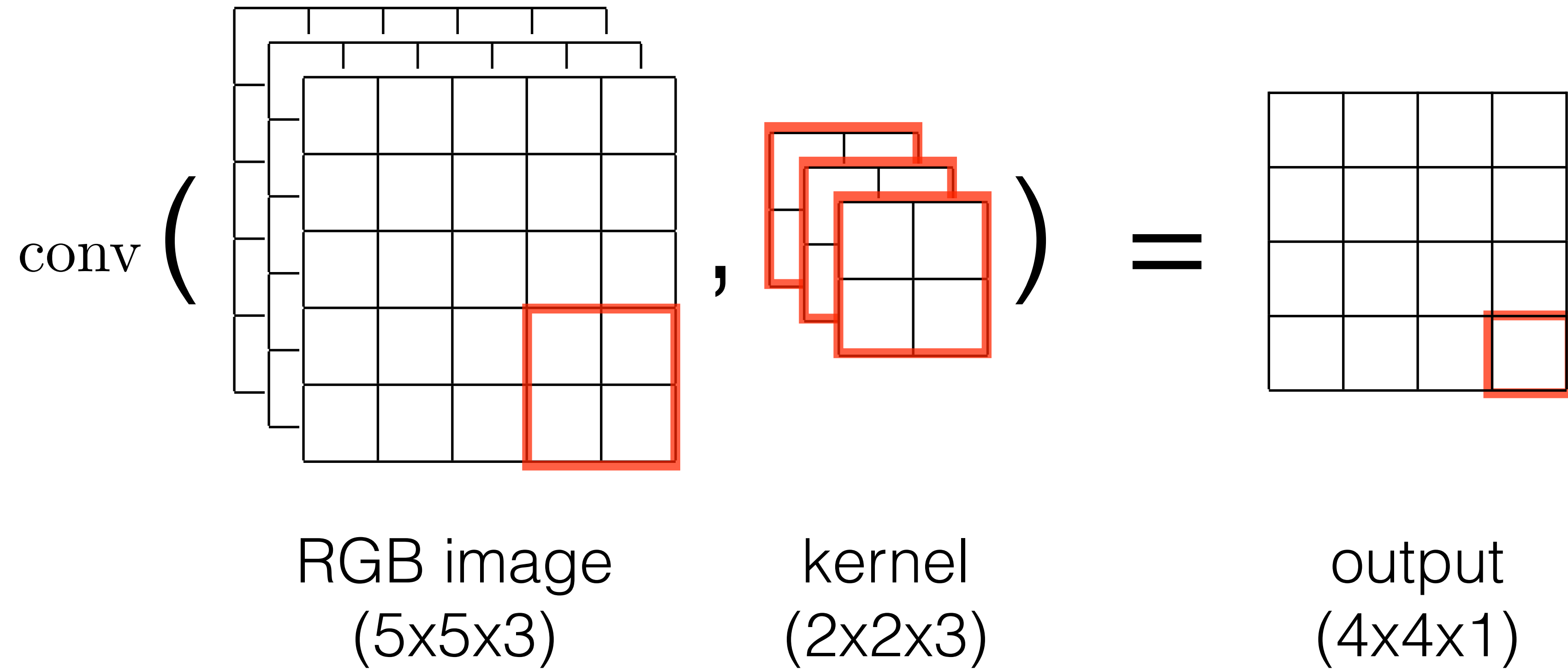

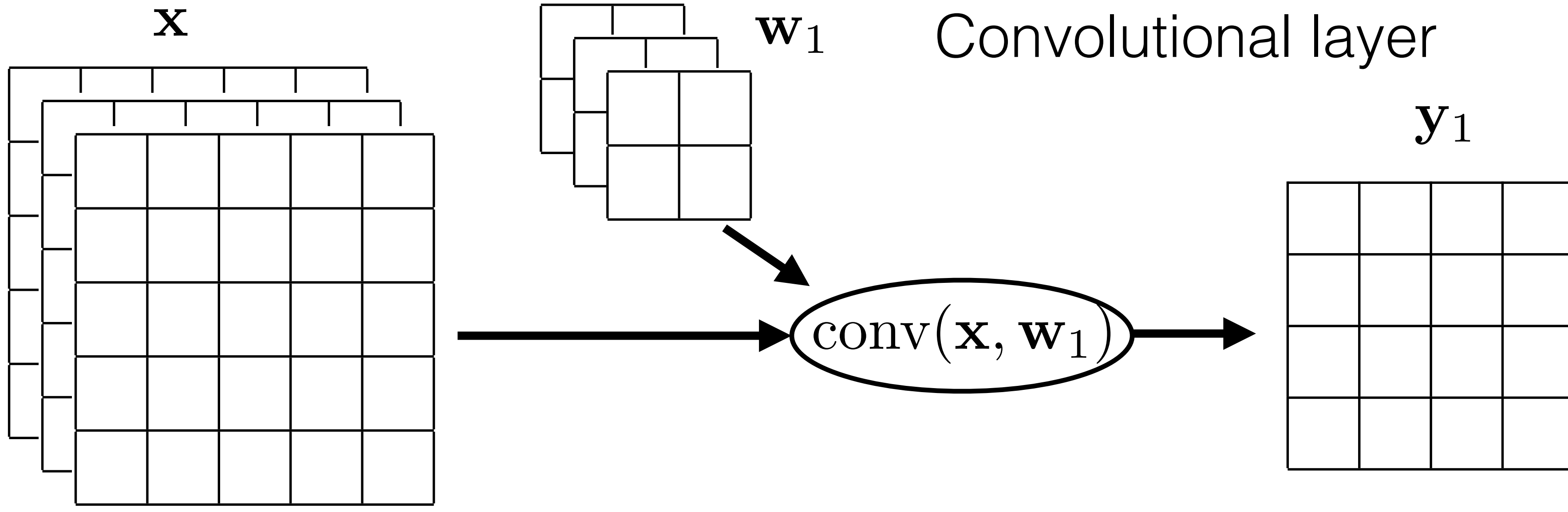

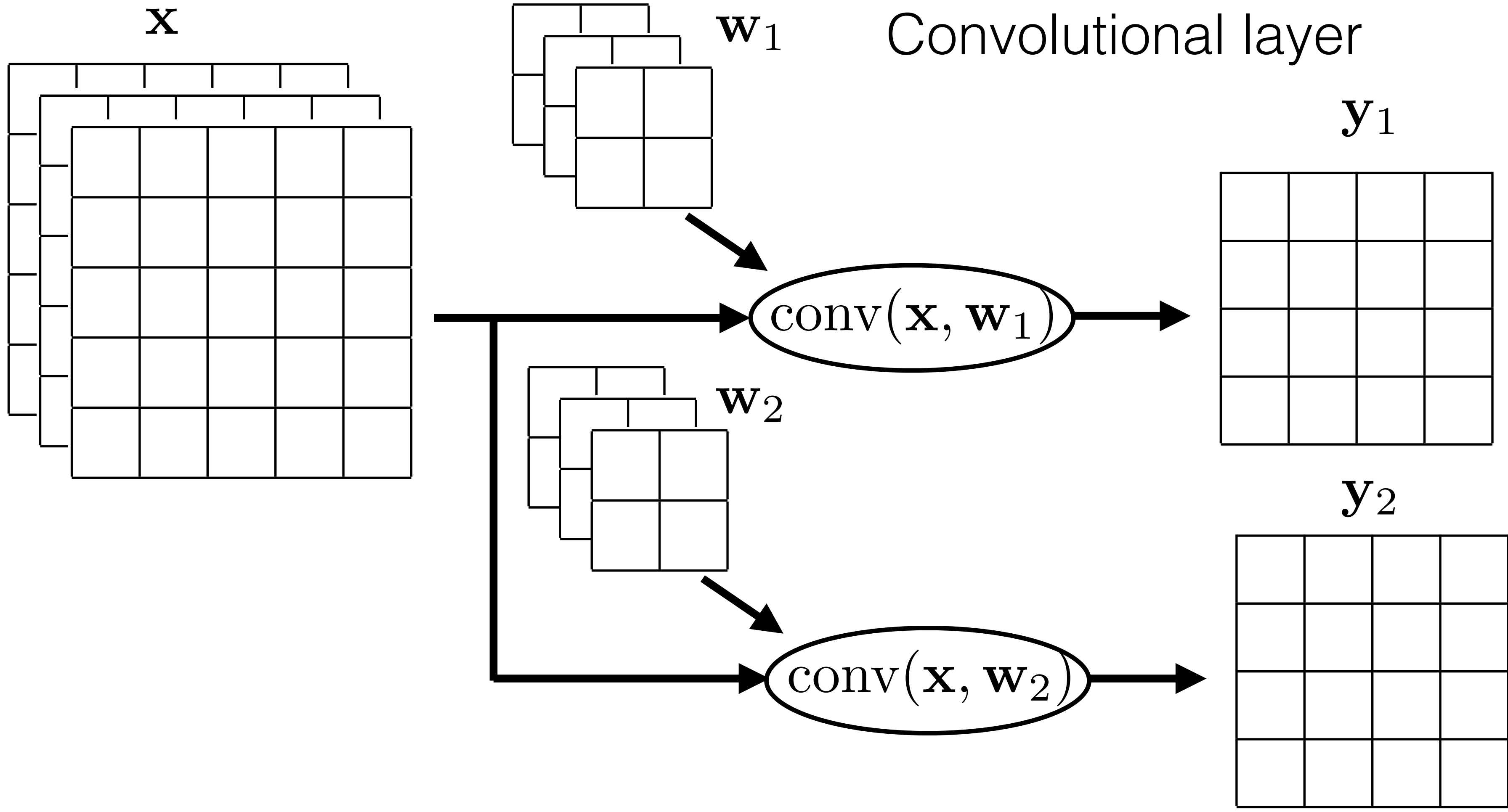

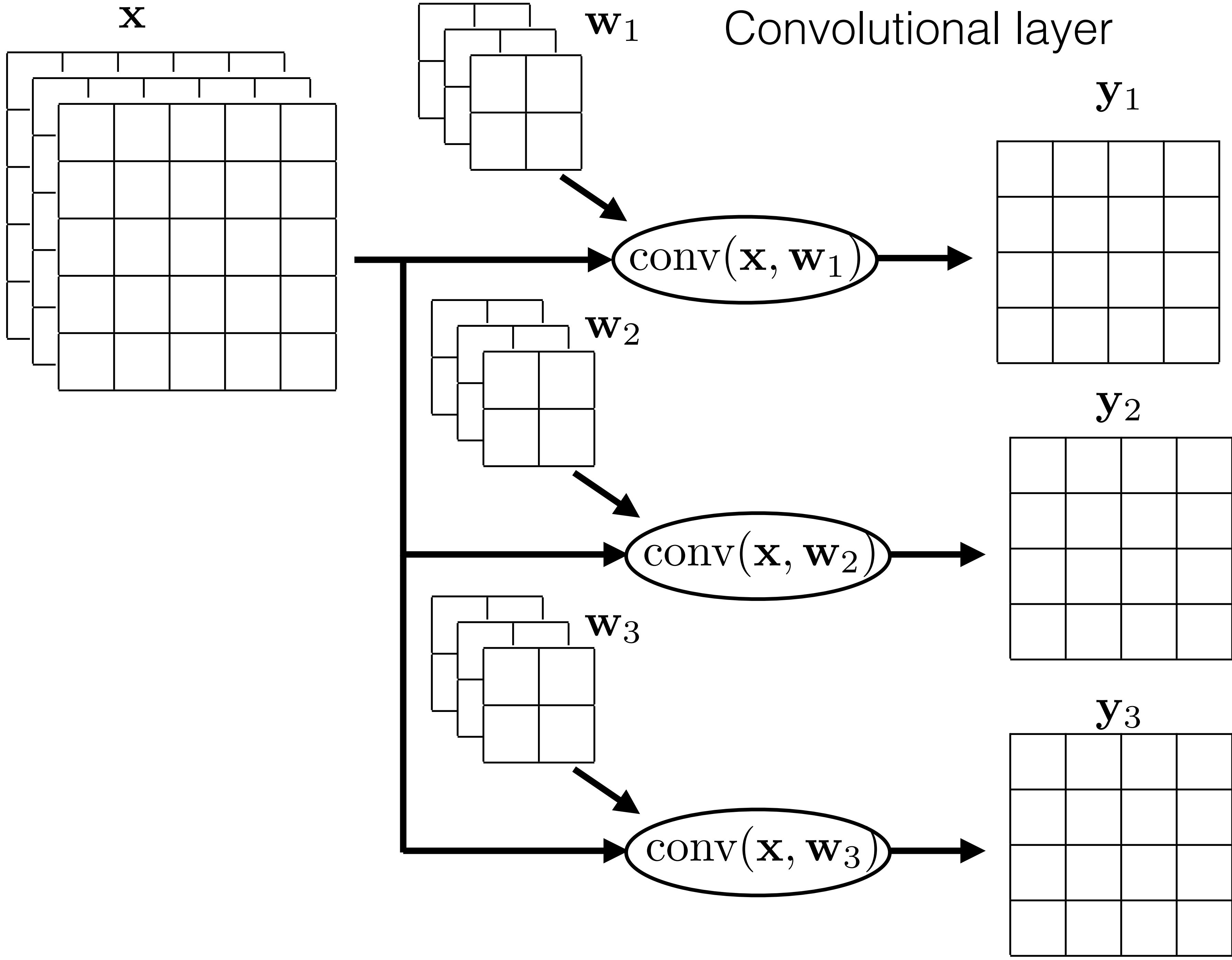

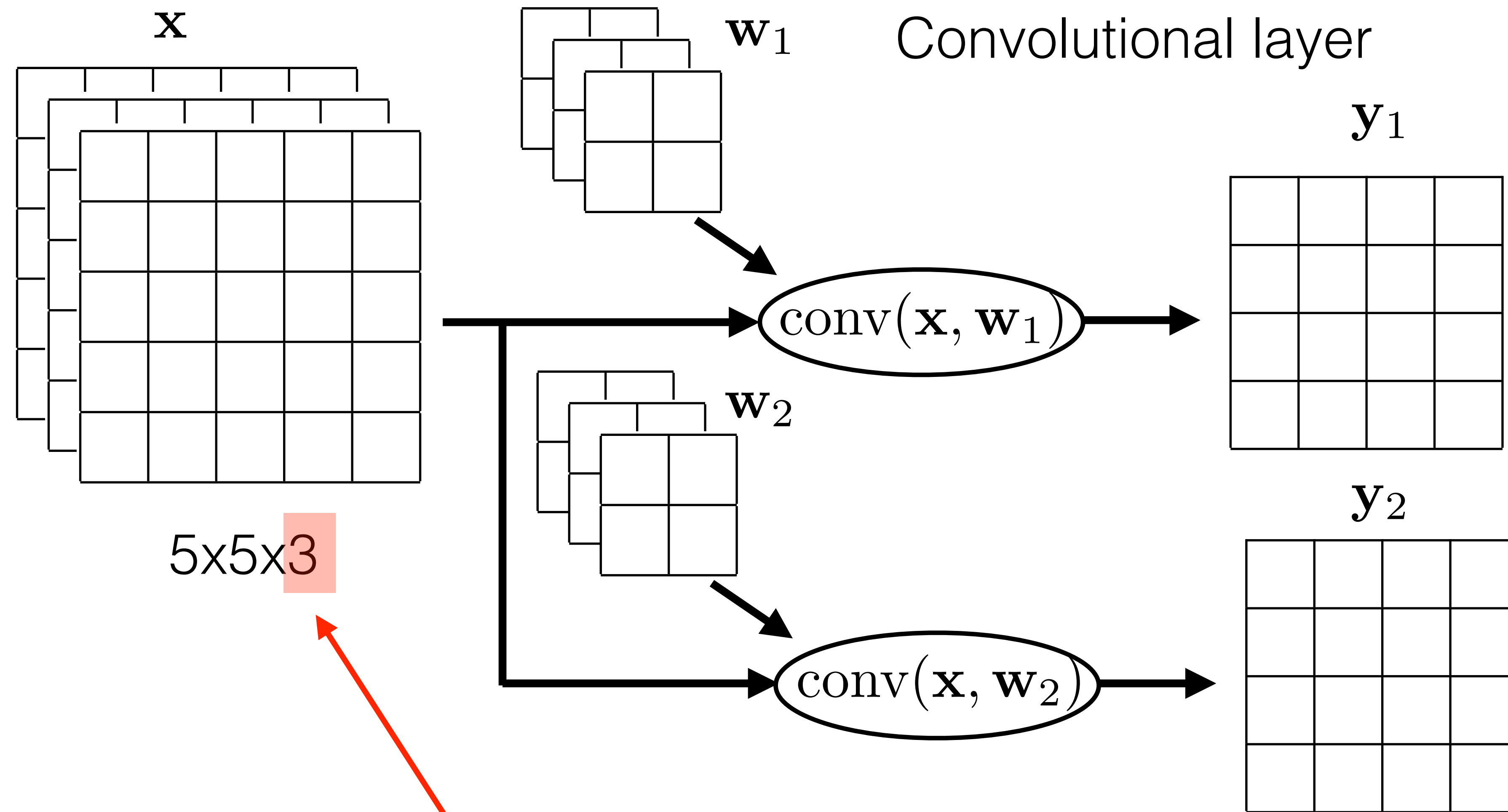

5x5x3

```
# initialise
import torch.nn as nn
# define 2D convolutional layer
first_layer = nn.Conv2d(in_channels=3, out_channels=2, kernel_size=2
                        stride=1, padding=1)
```

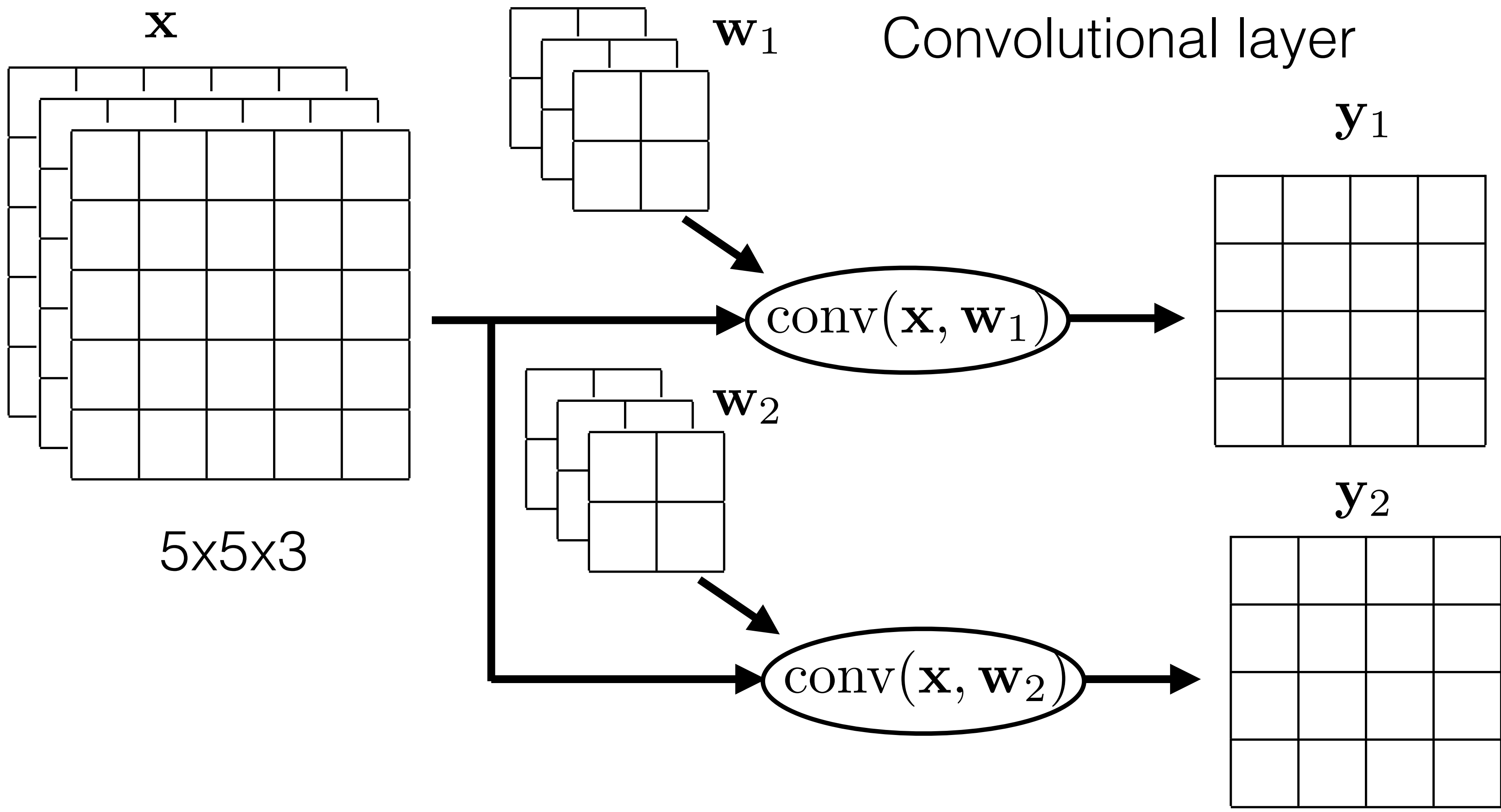

```
# initialise
import torch.nn as nn
# define 2D convolutional layer
first_layer = nn.Conv2d(in_channels=3, out_channels=2, kernel_size=2
                        stride=1, padding=1)
```

also number
of kernels

4x4x2

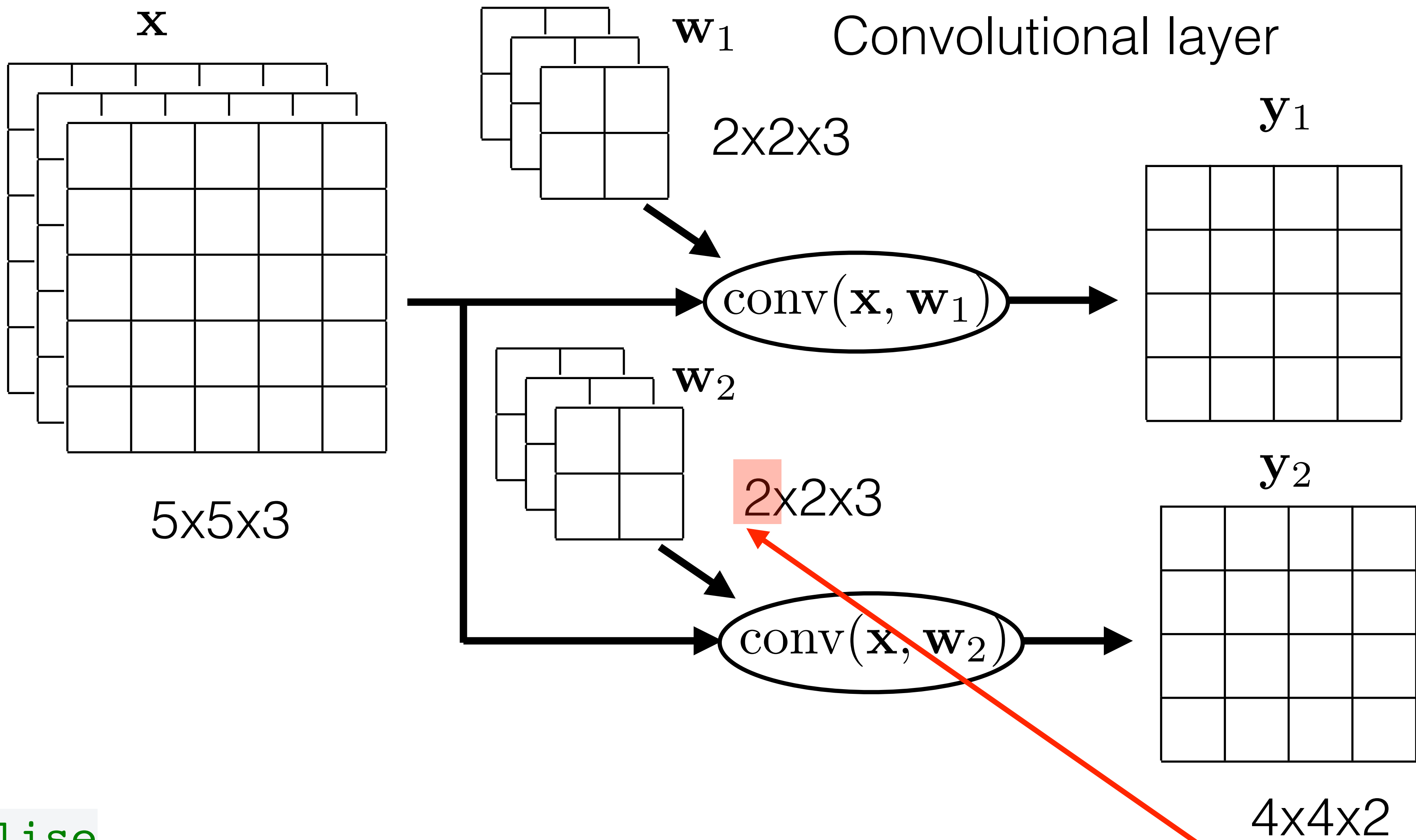

```
# initialise
import torch.nn as nn
# define 2D convolutional layer
first_layer = nn.Conv2d(in_channels=3, out_channels=2, kernel_size=2
                        stride=1, padding=1)
```

3. Neurons are sensitive to edges and its orientation

Inputs which maximized output of **layer 1**

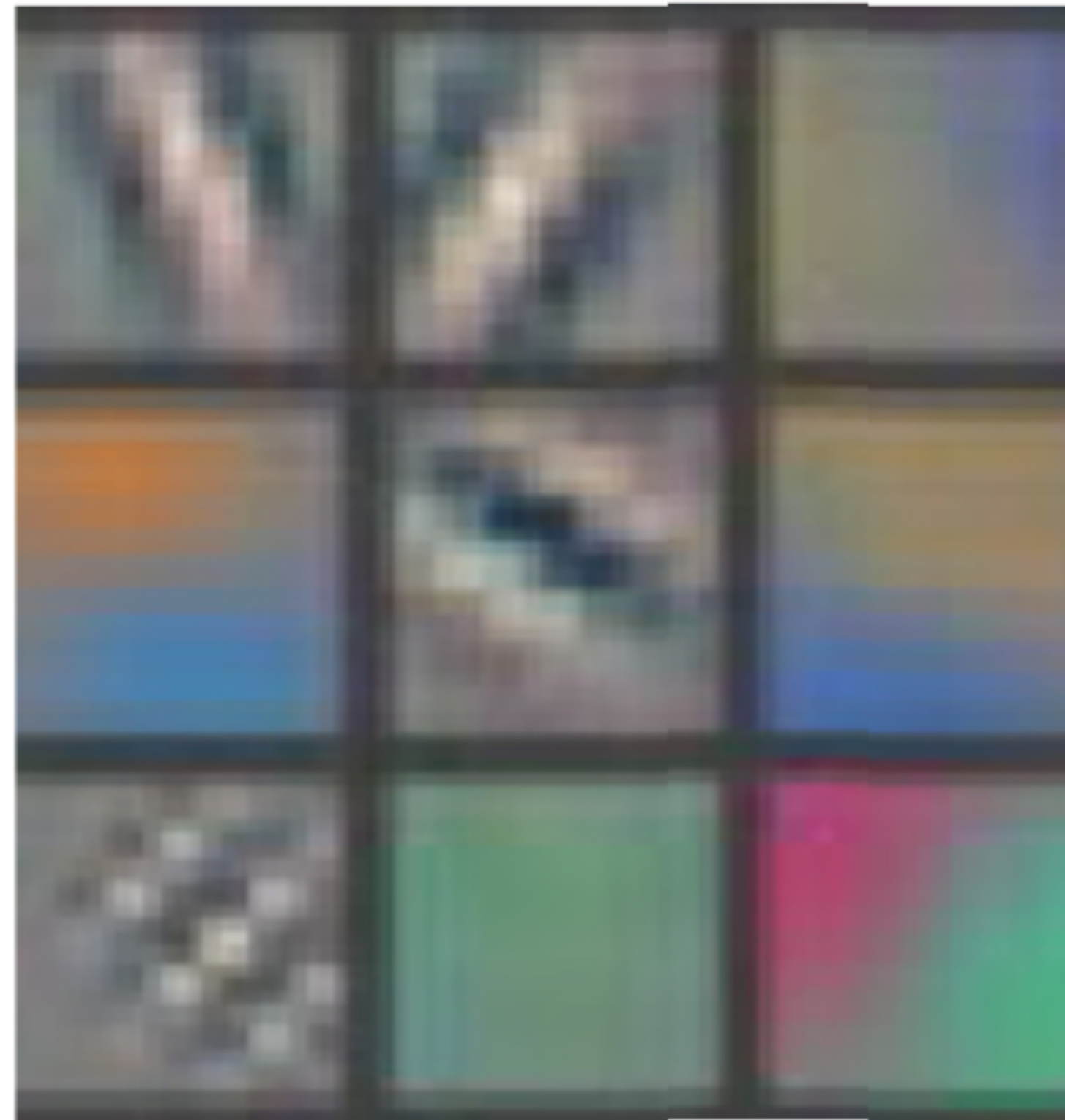

[Zeiler and Fergus, ECCV, 2014]

3. Neurons are sensitive to edges and its orientation

Inputs which maximized output of **layer 2**

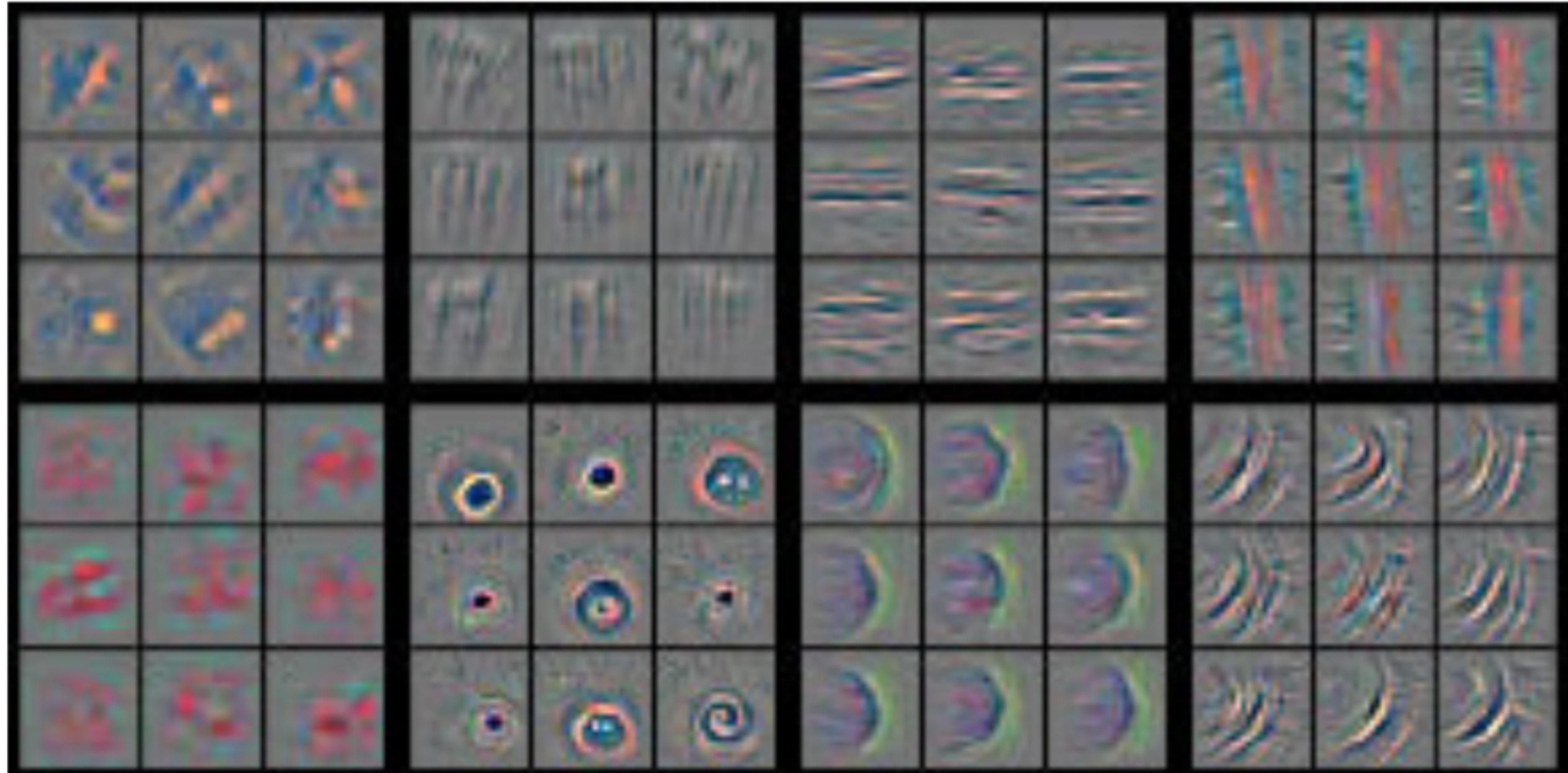

[Zeiler and Fergus, ECCV, 2014]

3. Neurons are sensitive to edges and its orientation

Inputs which maximized output of **layer 3**

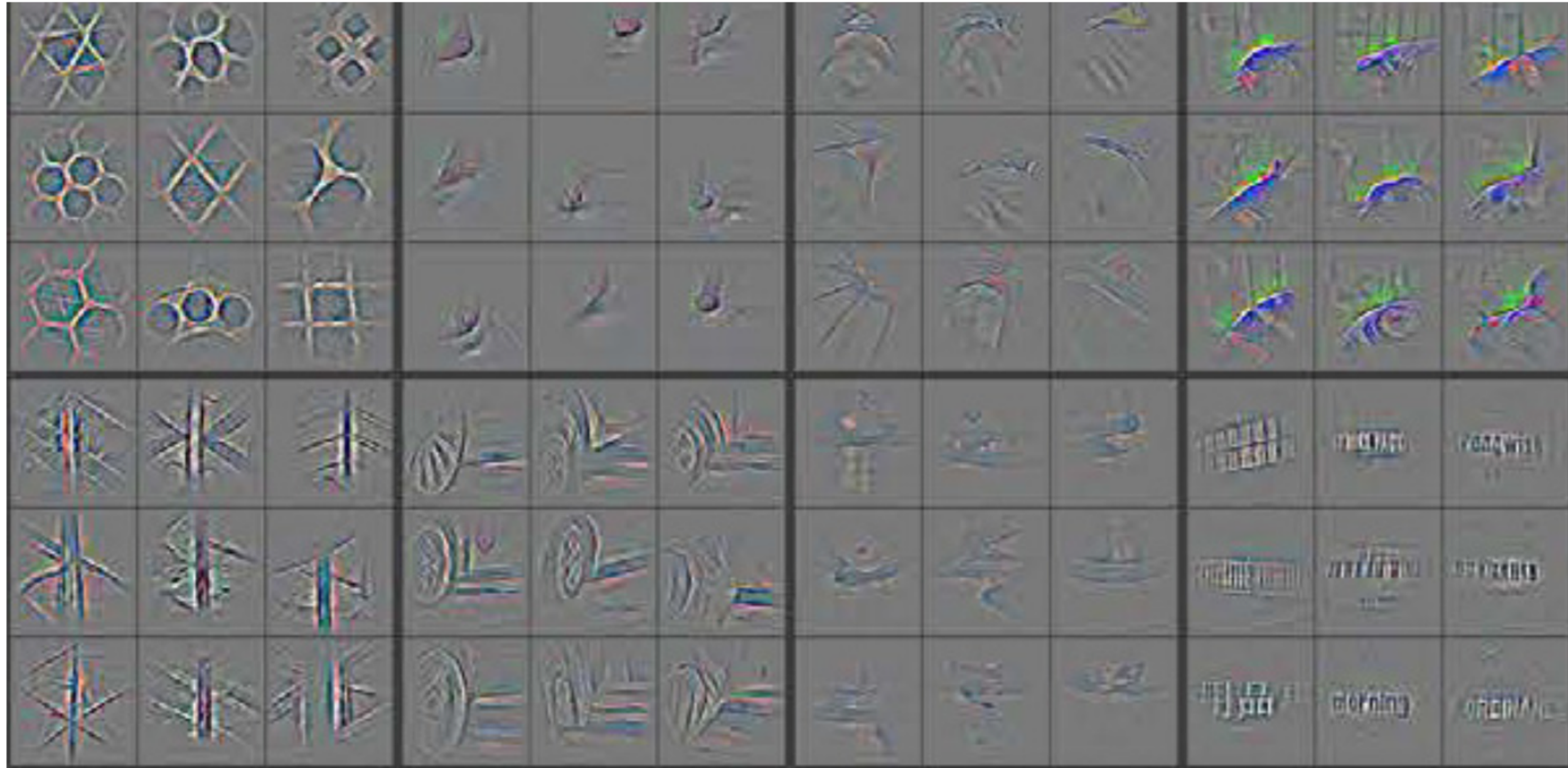

[Zeiler and Fergus, ECCV, 2014]

3. Neurons are sensitive to edges and its orientation

Inputs which maximized output of **layer 4**

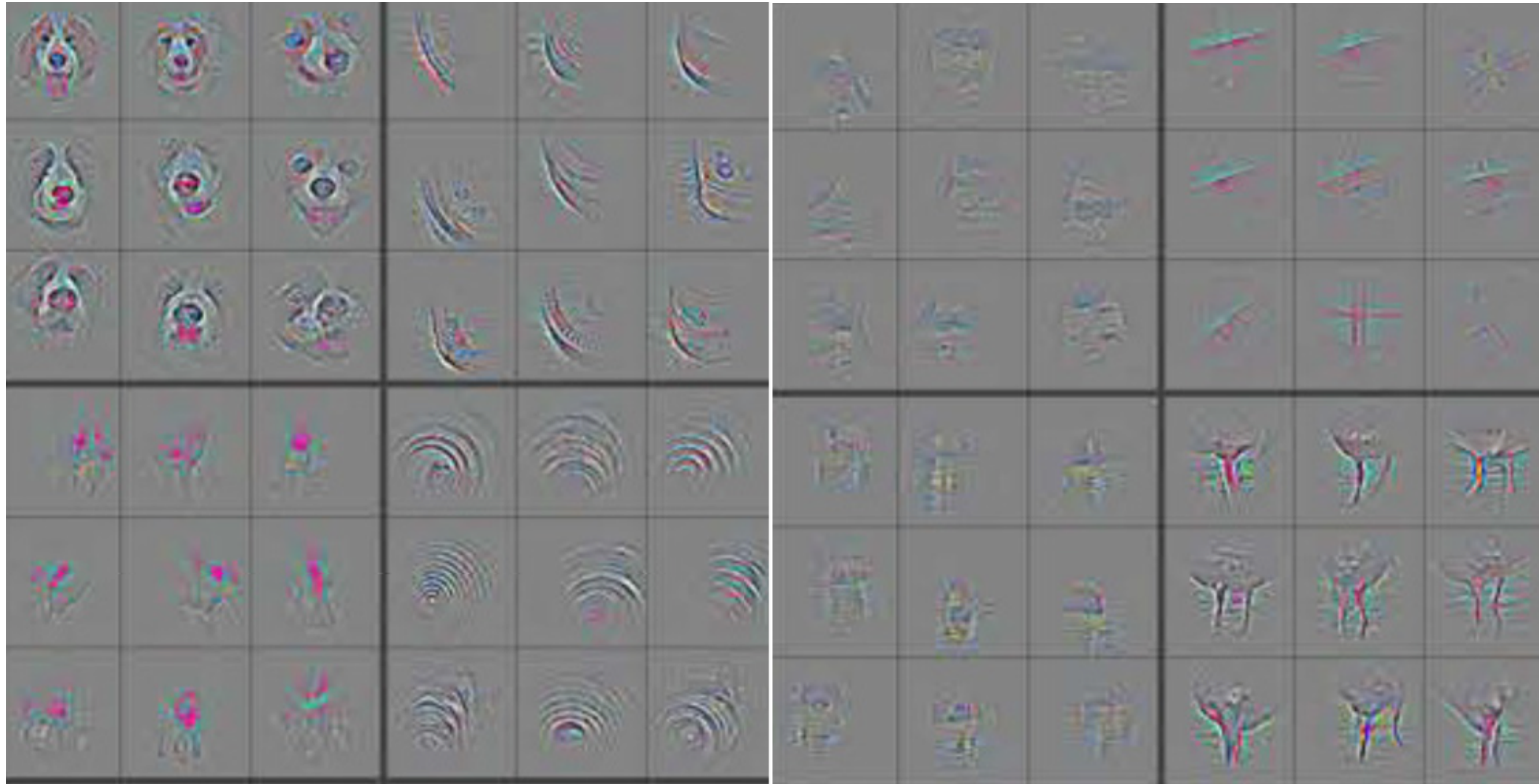

[Zeiler and Fergus, ECCV, 2014]

3. Neurons are sensitive to edges and its orientation

Inputs which maximized output of **layer 5**

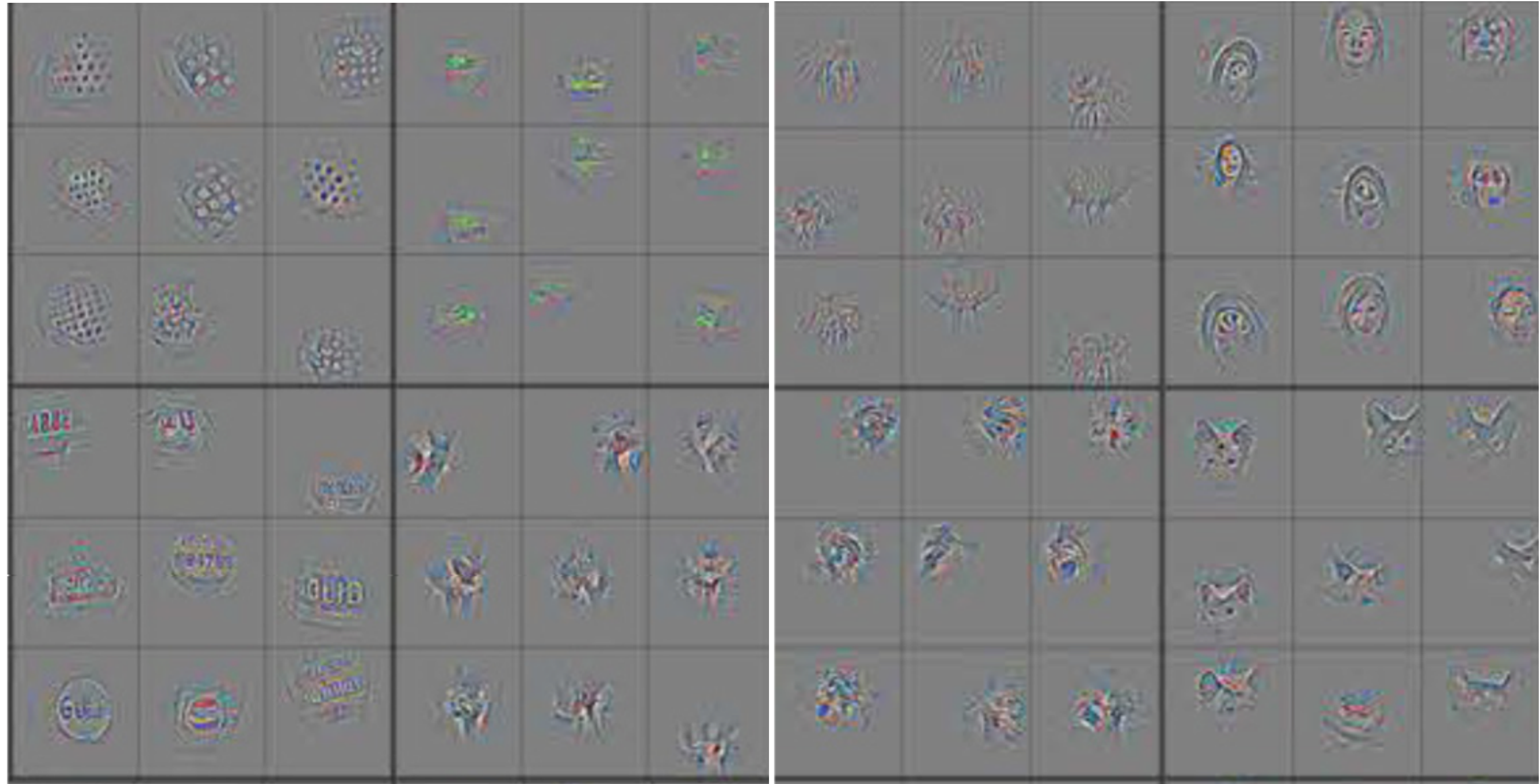

[Zeiler and Fergus, ECCV, 2014]

Convolution backward pass

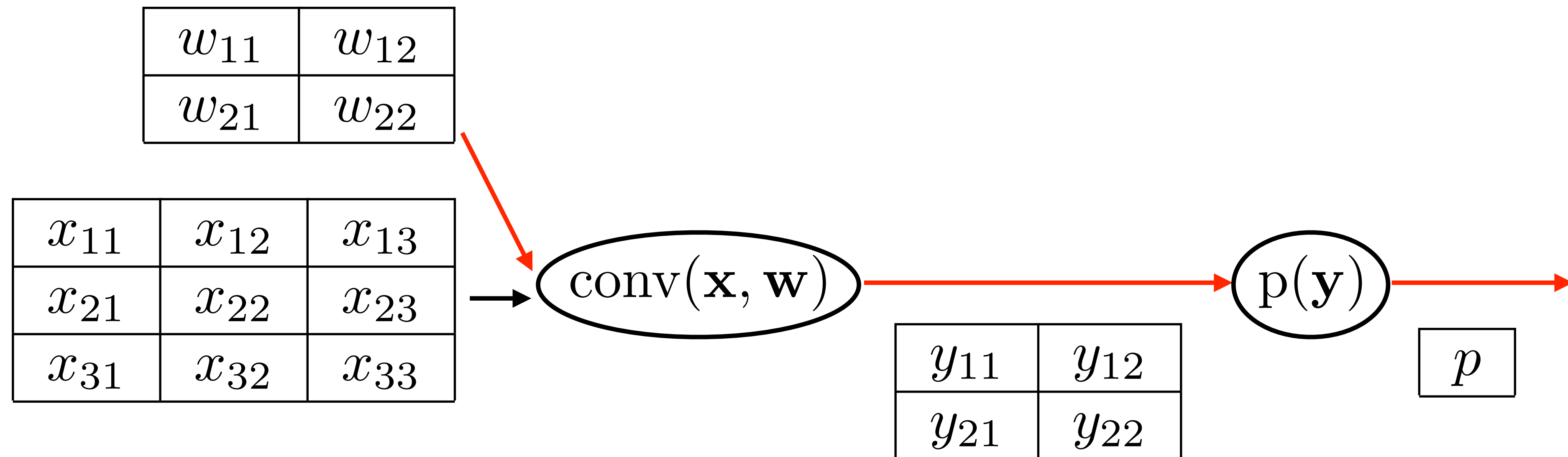

Convolution backward pass

$\frac{\partial p}{\partial w_{11}}$	$\frac{\partial p}{\partial w_{12}}$
$\frac{\partial p}{\partial w_{21}}$	$\frac{\partial p}{\partial w_{22}}$

 = ?

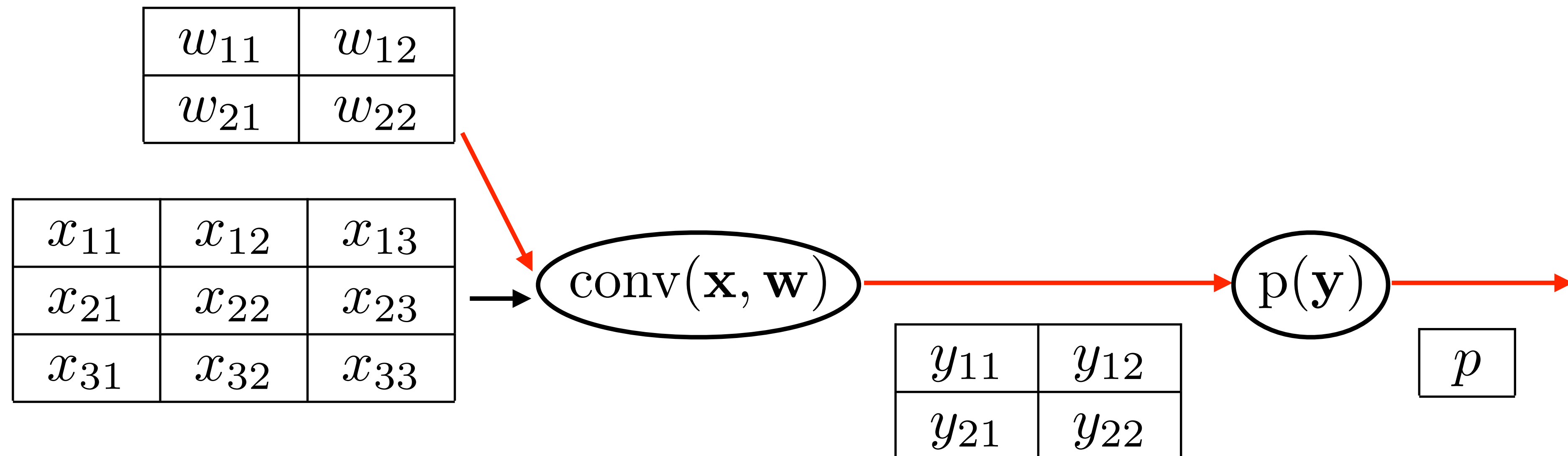

$\frac{\partial p}{\partial w_{11}}$	$\frac{\partial p}{\partial w_{12}}$
$\frac{\partial p}{\partial w_{21}}$	$\frac{\partial p}{\partial w_{22}}$

Convolution backward pass

$$\frac{\partial p}{\partial w_{11}} = ?$$

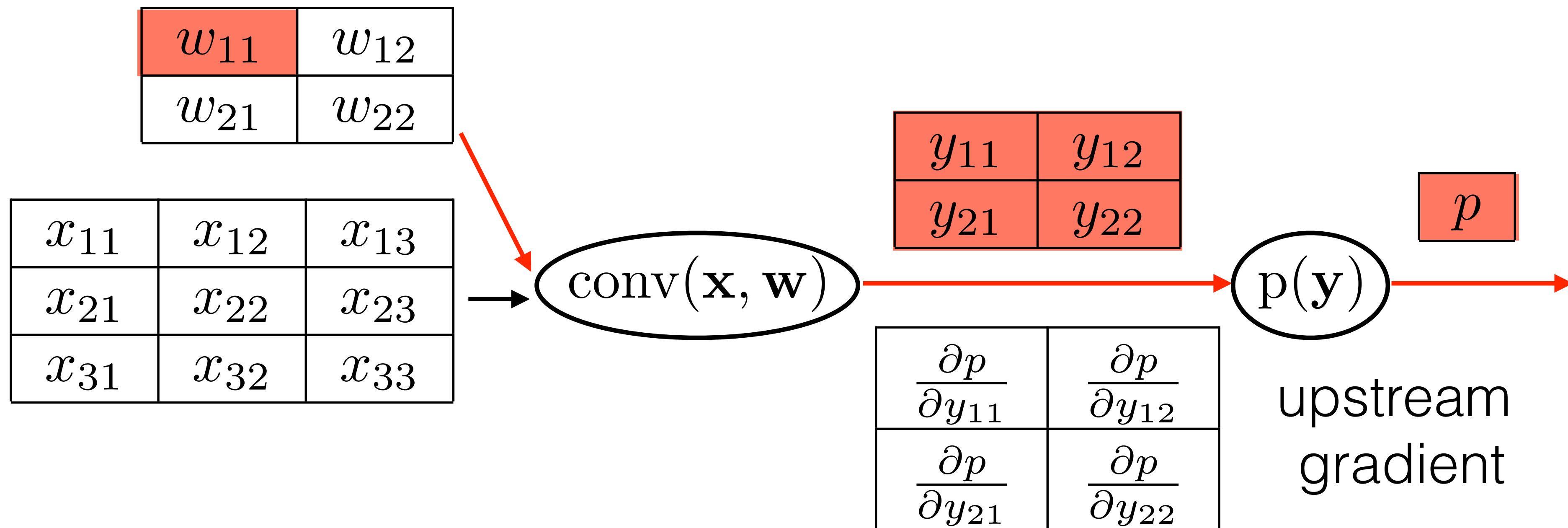

$\frac{\partial p}{\partial w_{11}}$	$\frac{\partial p}{\partial w_{12}}$
$\frac{\partial p}{\partial w_{21}}$	$\frac{\partial p}{\partial w_{22}}$

Convolution backward pass

$$\frac{\partial p}{\partial w_{11}} = \frac{\partial p}{\partial y_{11}} \frac{\partial y_{11}}{\partial w_{11}} + \frac{\partial p}{\partial y_{12}} \frac{\partial y_{12}}{\partial w_{11}} + \frac{\partial p}{\partial y_{21}} \frac{\partial y_{21}}{\partial w_{11}} + \frac{\partial p}{\partial y_{22}} \frac{\partial y_{22}}{\partial w_{11}}$$

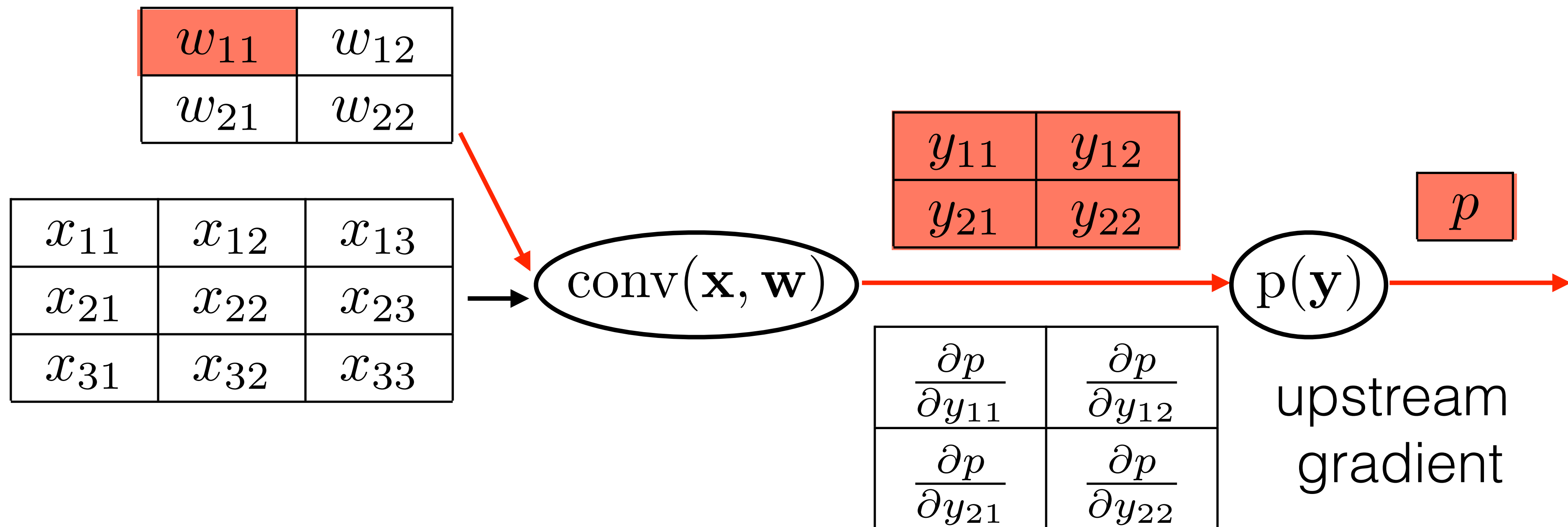

$\frac{\partial p}{\partial w_{11}}$	$\frac{\partial p}{\partial w_{12}}$
$\frac{\partial p}{\partial w_{21}}$	$\frac{\partial p}{\partial w_{22}}$

Convolution backward pass

$$\frac{\partial p}{\partial w_{11}} = \frac{\partial p}{\partial y_{11}} \frac{\partial y_{11}}{\partial w_{11}} + \frac{\partial p}{\partial y_{12}} \frac{\partial y_{12}}{\partial w_{11}} + \frac{\partial p}{\partial y_{21}} \frac{\partial y_{21}}{\partial w_{11}} + \frac{\partial p}{\partial y_{22}} \frac{\partial y_{22}}{\partial w_{11}}$$

$$\frac{\partial y_{11}}{\partial w_{11}} = ?$$

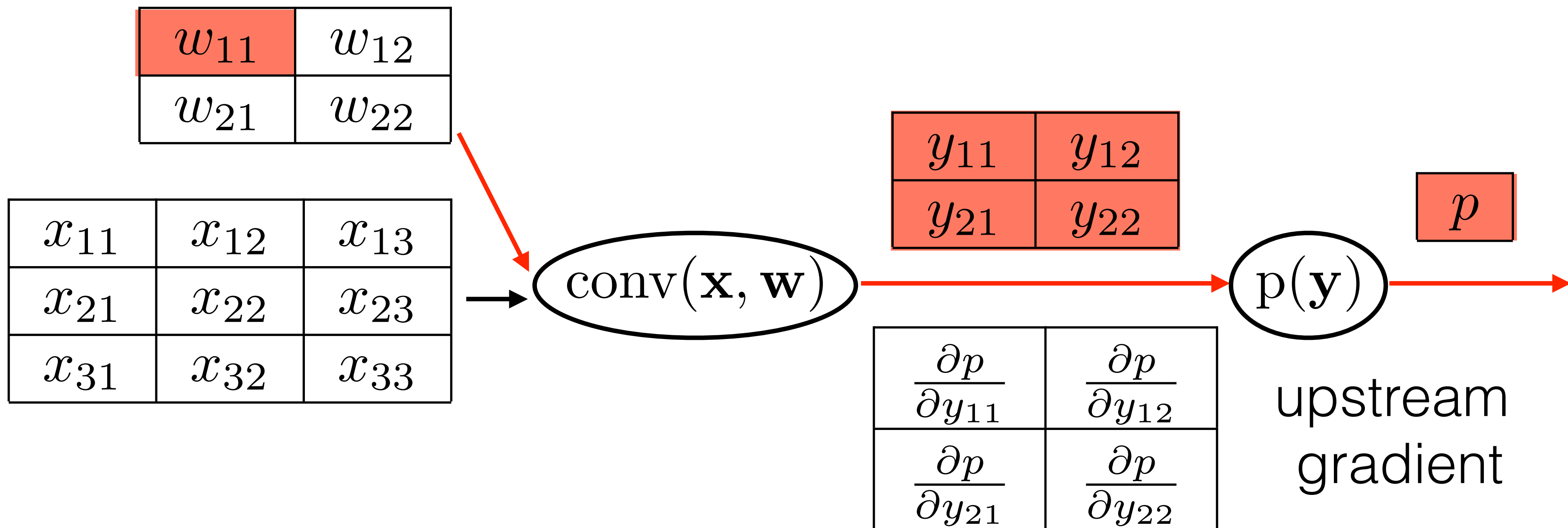

$\frac{\partial p}{\partial w_{11}}$	$\frac{\partial p}{\partial w_{12}}$
$\frac{\partial p}{\partial w_{21}}$	$\frac{\partial p}{\partial w_{22}}$

Convolution backward pass

$$\frac{\partial p}{\partial w_{11}} = \frac{\partial p}{\partial y_{11}} \frac{\partial y_{11}}{\partial w_{11}} + \frac{\partial p}{\partial y_{12}} \frac{\partial y_{12}}{\partial w_{11}} + \frac{\partial p}{\partial y_{21}} \frac{\partial y_{21}}{\partial w_{11}} + \frac{\partial p}{\partial y_{22}} \frac{\partial y_{22}}{\partial w_{11}}$$

$$\frac{\partial y_{11}}{\partial w_{11}} = \frac{\partial (w_{11}x_{11} + w_{12}x_{12} + w_{21}x_{21} + w_{22}x_{22})}{\partial w_{11}} = x_{11}$$

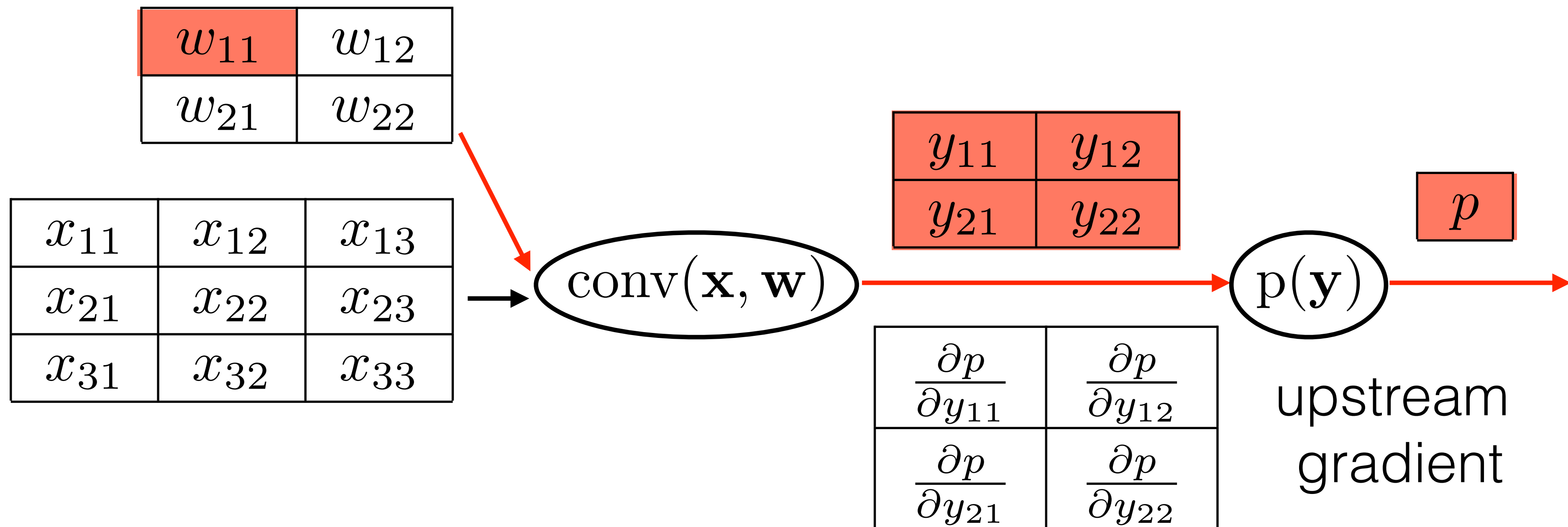

$\frac{\partial p}{\partial w_{11}}$	$\frac{\partial p}{\partial w_{12}}$
$\frac{\partial p}{\partial w_{21}}$	$\frac{\partial p}{\partial w_{22}}$

Convolution backward pass

$$\frac{\partial p}{\partial w_{11}} = \frac{\partial p}{\partial y_{11}} x_{11} + \frac{\partial p}{\partial y_{12}} x_{12} + \frac{\partial p}{\partial y_{21}} x_{21} + \frac{\partial p}{\partial y_{22}} x_{22}$$

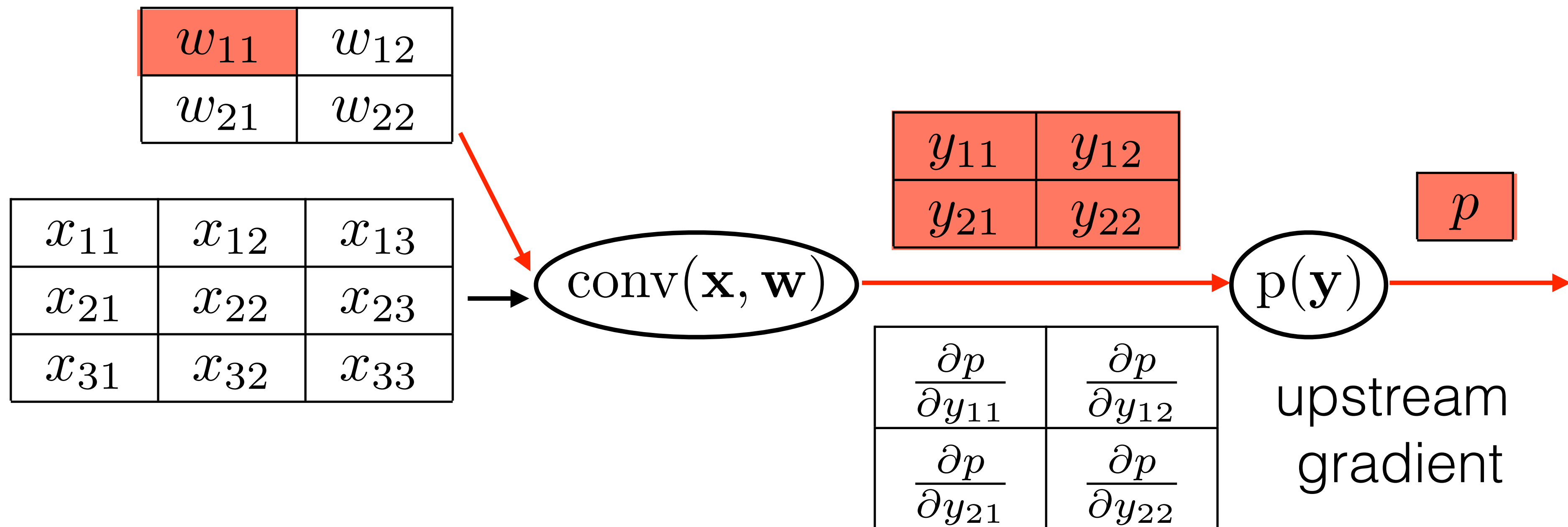

$\frac{\partial p}{\partial w_{11}}$	$\frac{\partial p}{\partial w_{12}}$
$\frac{\partial p}{\partial w_{21}}$	$\frac{\partial p}{\partial w_{22}}$

Convolution backward pass

$$\frac{\partial p}{\partial w_{11}} = \frac{\partial p}{\partial y_{11}} x_{11} + \frac{\partial p}{\partial y_{12}} x_{12} + \frac{\partial p}{\partial y_{21}} x_{21} + \frac{\partial p}{\partial y_{22}} x_{22}$$

$$\frac{\partial p}{\partial w_{12}} = ?$$

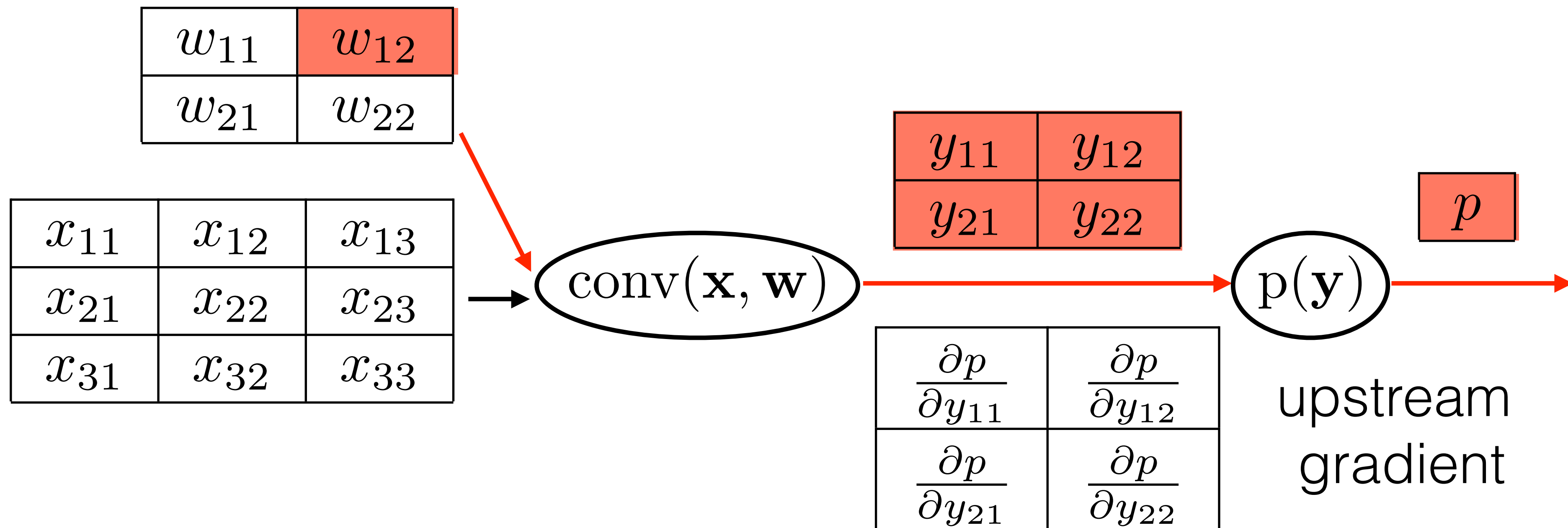

$\frac{\partial p}{\partial w_{11}}$	$\frac{\partial p}{\partial w_{12}}$
$\frac{\partial p}{\partial w_{21}}$	$\frac{\partial p}{\partial w_{22}}$

Convolution backward pass

$$\frac{\partial p}{\partial w_{11}} = \frac{\partial p}{\partial y_{11}} x_{11} + \frac{\partial p}{\partial y_{12}} x_{12} + \frac{\partial p}{\partial y_{21}} x_{21} + \frac{\partial p}{\partial y_{22}} x_{22}$$

$$\frac{\partial p}{\partial w_{12}} = \frac{\partial p}{\partial y_{11}} x_{12} + \frac{\partial p}{\partial y_{12}} x_{13} + \frac{\partial p}{\partial y_{21}} x_{22} + \frac{\partial p}{\partial y_{22}} x_{23}$$

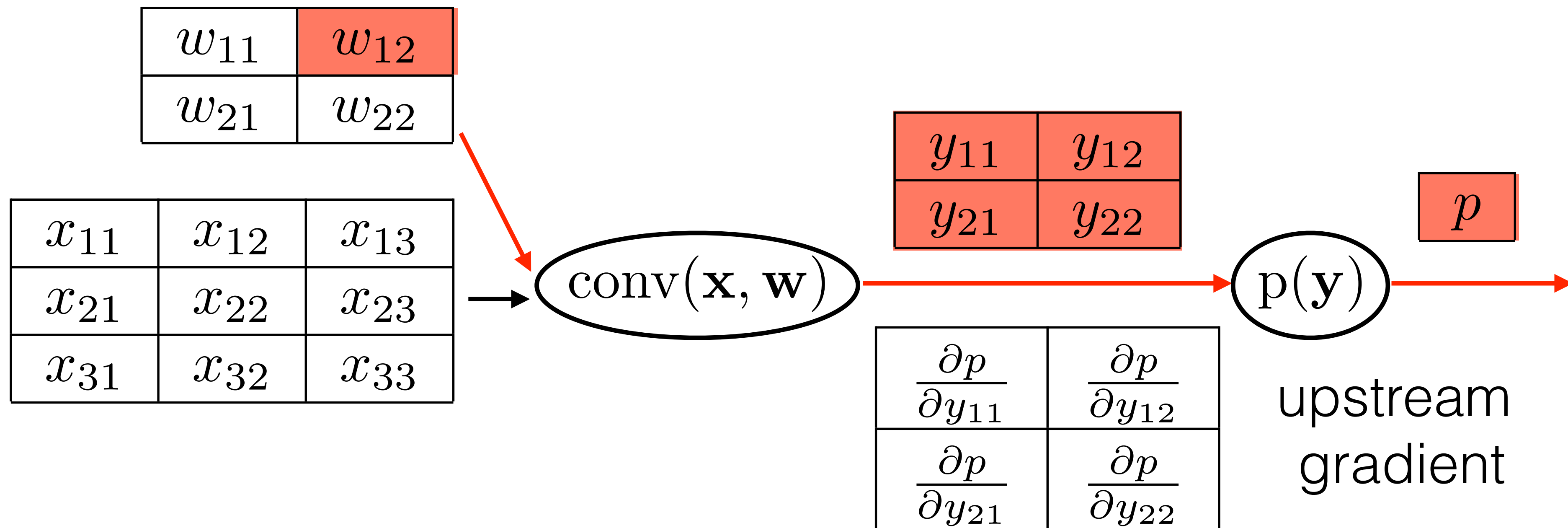

$\frac{\partial p}{\partial w_{11}}$	$\frac{\partial p}{\partial w_{12}}$
$\frac{\partial p}{\partial w_{21}}$	$\frac{\partial p}{\partial w_{22}}$

Convolution backward pass

$$\frac{\partial p}{\partial w_{11}} = \frac{\partial p}{\partial y_{11}} x_{11} + \frac{\partial p}{\partial y_{12}} x_{12} + \frac{\partial p}{\partial y_{21}} x_{21} + \frac{\partial p}{\partial y_{22}} x_{22}$$

$$\frac{\partial p}{\partial w_{12}} = \frac{\partial p}{\partial y_{11}} x_{12} + \frac{\partial p}{\partial y_{12}} x_{13} + \frac{\partial p}{\partial y_{21}} x_{22} + \frac{\partial p}{\partial y_{22}} x_{23}$$

$$\frac{\partial p}{\partial w_{21}} = \frac{\partial p}{\partial y_{11}} x_{21} + \frac{\partial p}{\partial y_{12}} x_{22} + \frac{\partial p}{\partial y_{21}} x_{31} + \frac{\partial p}{\partial y_{22}} x_{32}$$

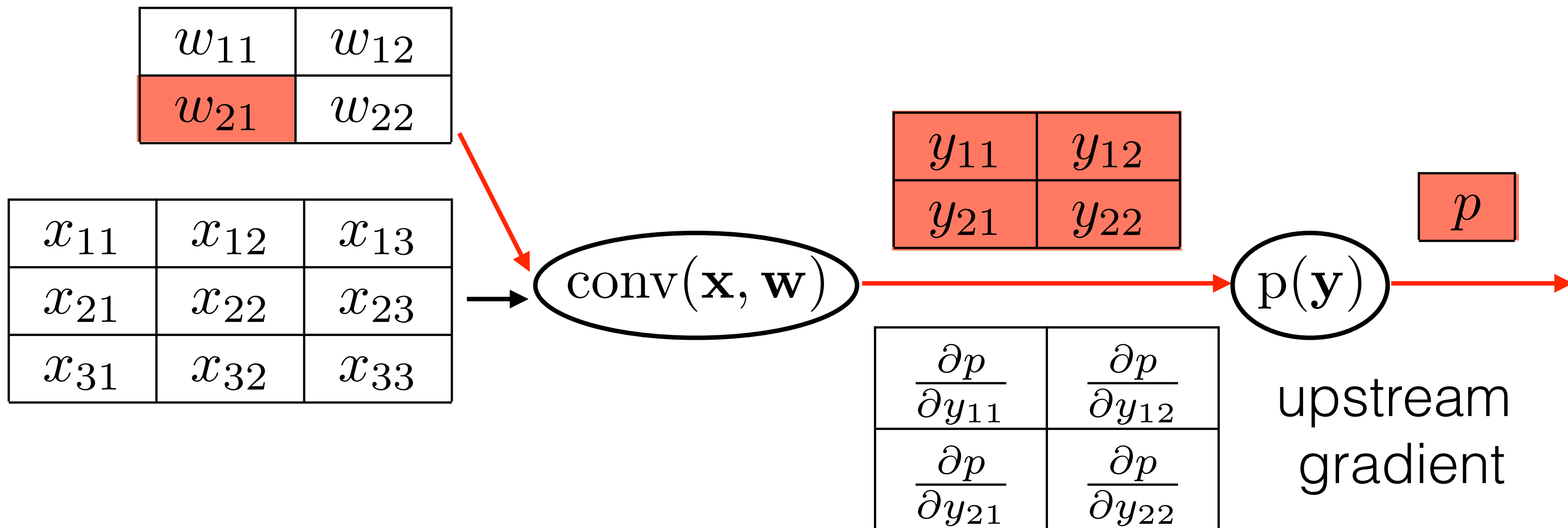

$\frac{\partial p}{\partial w_{11}}$	$\frac{\partial p}{\partial w_{12}}$
$\frac{\partial p}{\partial w_{21}}$	$\frac{\partial p}{\partial w_{22}}$

Convolution backward pass

$$\frac{\partial p}{\partial w_{11}} = \frac{\partial p}{\partial y_{11}} x_{11} + \frac{\partial p}{\partial y_{12}} x_{12} + \frac{\partial p}{\partial y_{21}} x_{21} + \frac{\partial p}{\partial y_{22}} x_{22}$$

$$\frac{\partial p}{\partial w_{12}} = \frac{\partial p}{\partial y_{11}} x_{12} + \frac{\partial p}{\partial y_{12}} x_{13} + \frac{\partial p}{\partial y_{21}} x_{22} + \frac{\partial p}{\partial y_{22}} x_{23}$$

$$\frac{\partial p}{\partial w_{21}} = \frac{\partial p}{\partial y_{11}} x_{21} + \frac{\partial p}{\partial y_{12}} x_{22} + \frac{\partial p}{\partial y_{21}} x_{31} + \frac{\partial p}{\partial y_{22}} x_{32}$$

$$\frac{\partial p}{\partial w_{22}} = \frac{\partial p}{\partial y_{11}} x_{22} + \frac{\partial p}{\partial y_{12}} x_{23} + \frac{\partial p}{\partial y_{21}} x_{32} + \frac{\partial p}{\partial y_{22}} x_{33}$$

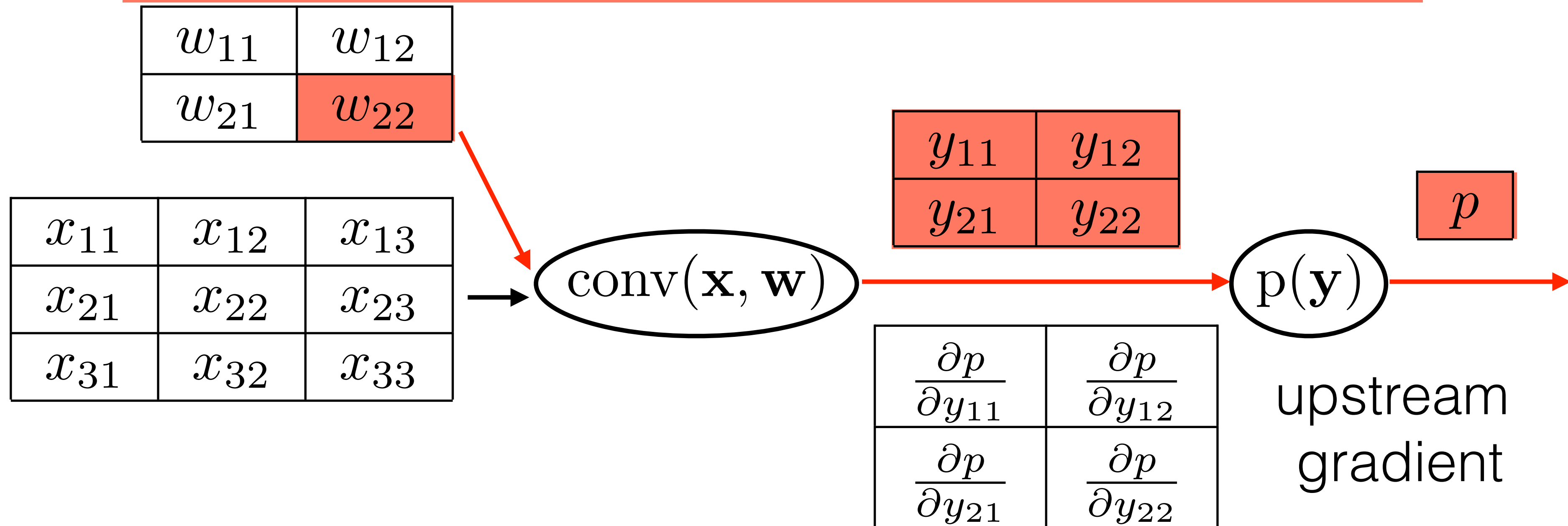

$\frac{\partial p}{\partial w_{11}}$	$\frac{\partial p}{\partial w_{12}}$
$\frac{\partial p}{\partial w_{21}}$	$\frac{\partial p}{\partial w_{22}}$

Convolution backward pass

$$\frac{\partial p}{\partial w_{11}} = \frac{\partial p}{\partial y_{11}} x_{11} + \frac{\partial p}{\partial y_{12}} x_{12} + \frac{\partial p}{\partial y_{21}} x_{21} + \frac{\partial p}{\partial y_{22}} x_{22}$$

$$\frac{\partial p}{\partial w_{12}} = \frac{\partial p}{\partial y_{11}} x_{12} + \frac{\partial p}{\partial y_{12}} x_{13} + \frac{\partial p}{\partial y_{21}} x_{22} + \frac{\partial p}{\partial y_{22}} x_{23}$$

$$\frac{\partial p}{\partial w_{21}} = \frac{\partial p}{\partial y_{11}} x_{21} + \frac{\partial p}{\partial y_{12}} x_{22} + \frac{\partial p}{\partial y_{21}} x_{31} + \frac{\partial p}{\partial y_{22}} x_{32}$$

$$\frac{\partial p}{\partial w_{22}} = \frac{\partial p}{\partial y_{11}} x_{22} + \frac{\partial p}{\partial y_{12}} x_{23} + \frac{\partial p}{\partial y_{21}} x_{32} + \frac{\partial p}{\partial y_{22}} x_{33}$$

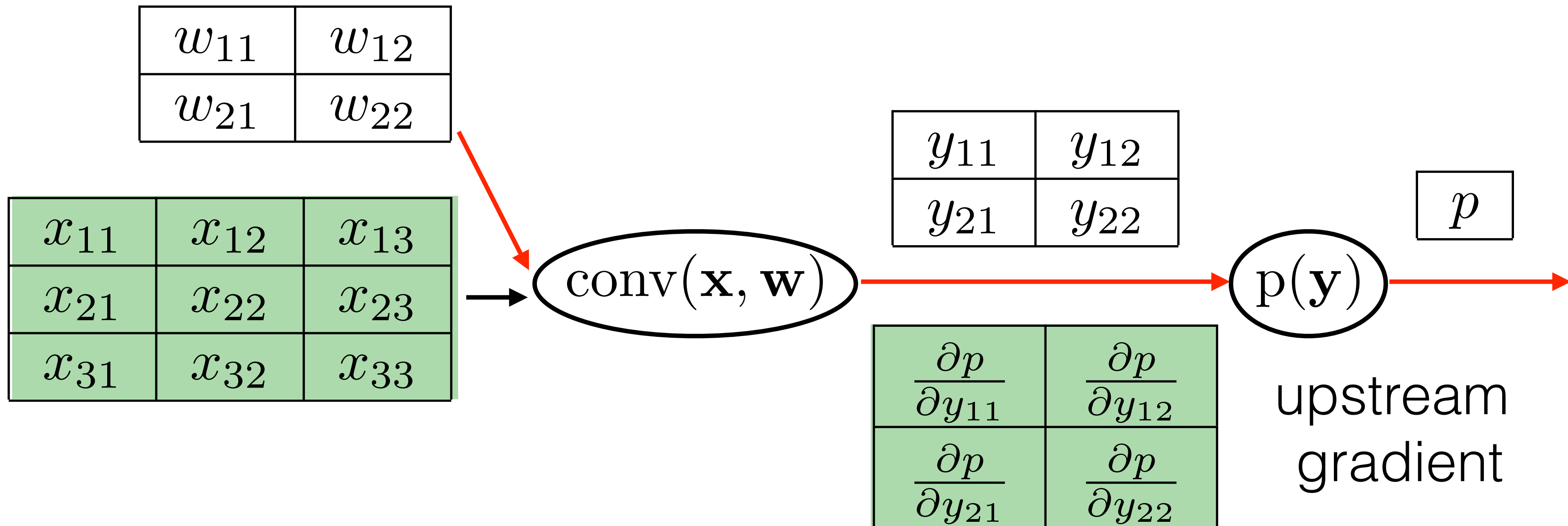

$\frac{\partial p}{\partial w_{11}}$	$\frac{\partial p}{\partial w_{12}}$
$\frac{\partial p}{\partial w_{21}}$	$\frac{\partial p}{\partial w_{22}}$

Convolution backward pass

$$\begin{aligned} \frac{\partial p}{\partial w_{11}} &= \frac{\partial p}{\partial y_{11}} x_{11} + \frac{\partial p}{\partial y_{12}} x_{12} + \frac{\partial p}{\partial y_{21}} x_{21} + \frac{\partial p}{\partial y_{22}} x_{22} \\ \frac{\partial p}{\partial w_{12}} &= \frac{\partial p}{\partial y_{11}} x_{12} + \frac{\partial p}{\partial y_{12}} x_{13} + \frac{\partial p}{\partial y_{21}} x_{22} + \frac{\partial p}{\partial y_{22}} x_{23} \\ \frac{\partial p}{\partial w_{21}} &= \frac{\partial p}{\partial y_{11}} x_{21} + \frac{\partial p}{\partial y_{12}} x_{22} + \frac{\partial p}{\partial y_{21}} x_{31} + \frac{\partial p}{\partial y_{22}} x_{32} \\ \frac{\partial p}{\partial w_{22}} &= \frac{\partial p}{\partial y_{11}} x_{22} + \frac{\partial p}{\partial y_{12}} x_{23} + \frac{\partial p}{\partial y_{21}} x_{32} + \frac{\partial p}{\partial y_{22}} x_{33} \end{aligned}$$

$$\begin{array}{|c|c|} \hline \frac{\partial p}{\partial w_{11}} & \frac{\partial p}{\partial w_{12}} \\ \hline \frac{\partial p}{\partial w_{21}} & \frac{\partial p}{\partial w_{22}} \\ \hline \end{array} = \text{conv} \left(\begin{array}{|c|c|c|} \hline x_{11} & x_{12} & x_{13} \\ \hline x_{21} & x_{22} & x_{23} \\ \hline x_{31} & x_{32} & x_{33} \\ \hline \end{array}, \begin{array}{|c|c|} \hline \frac{\partial p}{\partial y_{11}} & \frac{\partial p}{\partial y_{12}} \\ \hline \frac{\partial p}{\partial y_{21}} & \frac{\partial p}{\partial y_{22}} \\ \hline \end{array} \right)$$

$\frac{\partial p}{\partial w_{11}}$	$\frac{\partial p}{\partial w_{12}}$
$\frac{\partial p}{\partial w_{21}}$	$\frac{\partial p}{\partial w_{22}}$

Convolution backward pass

$$\frac{\partial p}{\partial w_{11}} = \frac{\partial p}{\partial y_{11}} x_{11} + \frac{\partial p}{\partial y_{12}} x_{12} + \frac{\partial p}{\partial y_{21}} x_{21} + \frac{\partial p}{\partial y_{22}} x_{22}$$

$$\frac{\partial p}{\partial w_{12}} = \frac{\partial p}{\partial y_{11}} x_{12} + \frac{\partial p}{\partial y_{12}} x_{13} + \frac{\partial p}{\partial y_{21}} x_{22} + \frac{\partial p}{\partial y_{22}} x_{23}$$

$$\frac{\partial p}{\partial w_{21}} = \frac{\partial p}{\partial y_{11}} x_{21} + \frac{\partial p}{\partial y_{12}} x_{22} + \frac{\partial p}{\partial y_{21}} x_{31} + \frac{\partial p}{\partial y_{22}} x_{32}$$

$$\frac{\partial p}{\partial w_{22}} = \frac{\partial p}{\partial y_{11}} x_{22} + \frac{\partial p}{\partial y_{12}} x_{23} + \frac{\partial p}{\partial y_{21}} x_{32} + \frac{\partial p}{\partial y_{22}} x_{33}$$

$\frac{\partial p}{\partial w_{11}}$	$\frac{\partial p}{\partial w_{12}}$
$\frac{\partial p}{\partial w_{21}}$	$\frac{\partial p}{\partial w_{22}}$

$$= \text{conv} \left(\begin{array}{|c|c|c|} \hline x_{11} & x_{12} & x_{13} \\ \hline x_{21} & x_{22} & x_{23} \\ \hline x_{31} & x_{32} & x_{33} \\ \hline \end{array}, \begin{array}{|c|c|} \hline \frac{\partial p}{\partial y_{11}} & \frac{\partial p}{\partial y_{12}} \\ \hline \frac{\partial p}{\partial y_{21}} & \frac{\partial p}{\partial y_{22}} \\ \hline \end{array} \right)$$

$\frac{\partial p}{\partial w_{11}}$	$\frac{\partial p}{\partial w_{12}}$
$\frac{\partial p}{\partial w_{21}}$	$\frac{\partial p}{\partial w_{22}}$

Convolution backward pass

$$\frac{\partial p}{\partial w_{11}} = \frac{\partial p}{\partial y_{11}} x_{11} + \frac{\partial p}{\partial y_{12}} x_{12} + \frac{\partial p}{\partial y_{21}} x_{21} + \frac{\partial p}{\partial y_{22}} x_{22}$$

$$\frac{\partial p}{\partial w_{12}} = \frac{\partial p}{\partial y_{11}} x_{12} + \frac{\partial p}{\partial y_{12}} x_{13} + \frac{\partial p}{\partial y_{21}} x_{22} + \frac{\partial p}{\partial y_{22}} x_{23}$$

$$\frac{\partial p}{\partial w_{21}} = \frac{\partial p}{\partial y_{11}} x_{21} + \frac{\partial p}{\partial y_{12}} x_{22} + \frac{\partial p}{\partial y_{21}} x_{31} + \frac{\partial p}{\partial y_{22}} x_{32}$$

$$\frac{\partial p}{\partial w_{22}} = \frac{\partial p}{\partial y_{11}} x_{22} + \frac{\partial p}{\partial y_{12}} x_{23} + \frac{\partial p}{\partial y_{21}} x_{32} + \frac{\partial p}{\partial y_{22}} x_{33}$$

$\frac{\partial p}{\partial w_{11}}$	$\frac{\partial p}{\partial w_{12}}$
$\frac{\partial p}{\partial w_{21}}$	$\frac{\partial p}{\partial w_{22}}$

$$= \text{conv} \left(\begin{array}{|c|c|c|} \hline x_{11} & x_{12} & x_{13} \\ \hline x_{21} & x_{22} & x_{23} \\ \hline x_{31} & x_{32} & x_{33} \\ \hline \end{array}, \begin{array}{|c|c|} \hline \frac{\partial p}{\partial y_{11}} & \frac{\partial p}{\partial y_{12}} \\ \hline \frac{\partial p}{\partial y_{21}} & \frac{\partial p}{\partial y_{22}} \\ \hline \end{array} \right)$$

$\frac{\partial p}{\partial w_{11}}$	$\frac{\partial p}{\partial w_{12}}$
$\frac{\partial p}{\partial w_{21}}$	$\frac{\partial p}{\partial w_{22}}$

Convolution backward pass

$$\begin{aligned} \frac{\partial p}{\partial w_{11}} &= \frac{\partial p}{\partial y_{11}} x_{11} + \frac{\partial p}{\partial y_{12}} x_{12} + \frac{\partial p}{\partial y_{21}} x_{21} + \frac{\partial p}{\partial y_{22}} x_{22} \\ \frac{\partial p}{\partial w_{12}} &= \frac{\partial p}{\partial y_{11}} x_{12} + \frac{\partial p}{\partial y_{12}} x_{13} + \frac{\partial p}{\partial y_{21}} x_{22} + \frac{\partial p}{\partial y_{22}} x_{23} \\ \frac{\partial p}{\partial w_{21}} &= \frac{\partial p}{\partial y_{11}} x_{21} + \frac{\partial p}{\partial y_{12}} x_{22} + \frac{\partial p}{\partial y_{21}} x_{31} + \frac{\partial p}{\partial y_{22}} x_{32} \\ \frac{\partial p}{\partial w_{22}} &= \frac{\partial p}{\partial y_{11}} x_{22} + \frac{\partial p}{\partial y_{12}} x_{23} + \frac{\partial p}{\partial y_{21}} x_{32} + \frac{\partial p}{\partial y_{22}} x_{33} \end{aligned}$$

$$\begin{array}{|c|c|} \hline \frac{\partial p}{\partial w_{11}} & \frac{\partial p}{\partial w_{12}} \\ \hline \frac{\partial p}{\partial w_{21}} & \frac{\partial p}{\partial w_{22}} \\ \hline \end{array} = \text{conv} \left(\begin{array}{|c|c|c|} \hline x_{11} & x_{12} & x_{13} \\ \hline x_{21} & x_{22} & x_{23} \\ \hline x_{31} & x_{32} & x_{33} \\ \hline \end{array}, \begin{array}{|c|c|} \hline \frac{\partial p}{\partial y_{11}} & \frac{\partial p}{\partial y_{12}} \\ \hline \frac{\partial p}{\partial y_{21}} & \frac{\partial p}{\partial y_{22}} \\ \hline \end{array} \right)$$

$\frac{\partial p}{\partial w_{11}}$	$\frac{\partial p}{\partial w_{12}}$
$\frac{\partial p}{\partial w_{21}}$	$\frac{\partial p}{\partial w_{22}}$

Convolution backward pass

$$\begin{aligned} \frac{\partial p}{\partial w_{11}} &= \frac{\partial p}{\partial y_{11}} x_{11} + \frac{\partial p}{\partial y_{12}} x_{12} + \frac{\partial p}{\partial y_{21}} x_{21} + \frac{\partial p}{\partial y_{22}} x_{22} \\ \frac{\partial p}{\partial w_{12}} &= \frac{\partial p}{\partial y_{11}} x_{12} + \frac{\partial p}{\partial y_{12}} x_{13} + \frac{\partial p}{\partial y_{21}} x_{22} + \frac{\partial p}{\partial y_{22}} x_{23} \\ \frac{\partial p}{\partial w_{21}} &= \frac{\partial p}{\partial y_{11}} x_{21} + \frac{\partial p}{\partial y_{12}} x_{22} + \frac{\partial p}{\partial y_{21}} x_{31} + \frac{\partial p}{\partial y_{22}} x_{32} \\ \frac{\partial p}{\partial w_{22}} &= \frac{\partial p}{\partial y_{11}} x_{22} + \frac{\partial p}{\partial y_{12}} x_{23} + \frac{\partial p}{\partial y_{21}} x_{32} + \frac{\partial p}{\partial y_{22}} x_{33} \end{aligned}$$

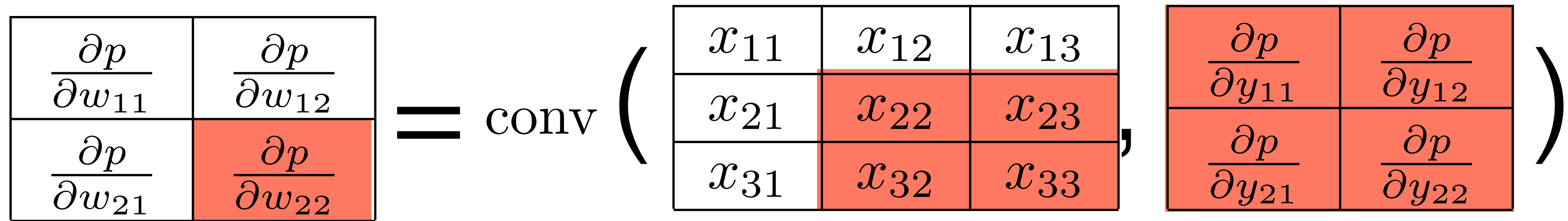

Convolution backward pass wrt weights

- Backpropagation in convolutional layer wrt weights is:
“convolution of input feature map with upstream gradient”

$$\text{vjp}_{\text{conv}_w} \left(\frac{\partial p}{\partial \mathbf{y}} \right) = \begin{pmatrix} \frac{\partial p}{\partial w_{11}} & \frac{\partial p}{\partial w_{12}} \\ \frac{\partial p}{\partial w_{21}} & \frac{\partial p}{\partial w_{22}} \end{pmatrix} = \text{conv} \left(\begin{pmatrix} x_{11} & x_{12} & x_{13} \\ x_{21} & x_{22} & x_{23} \\ x_{31} & x_{32} & x_{33} \end{pmatrix}, \begin{pmatrix} \frac{\partial p}{\partial y_{11}} & \frac{\partial p}{\partial y_{12}} \\ \frac{\partial p}{\partial y_{21}} & \frac{\partial p}{\partial y_{22}} \end{pmatrix} \right)$$

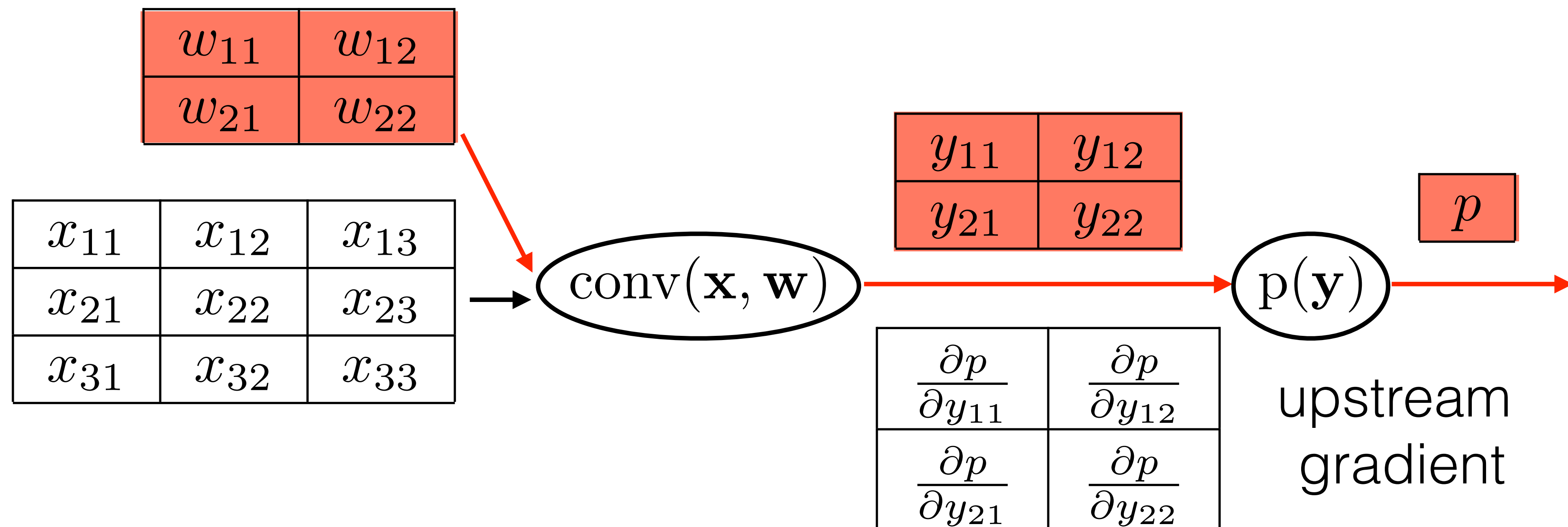

Convolution backward pass wrt input feature map

- Backpropagation in convolutional layer is:
“convolution of padded upstream gradient with mirrored weights”

$$\text{vjp}_{\text{conv}_x} \left(\frac{\partial p}{\partial \mathbf{y}} \right) = \begin{matrix} \frac{\partial p}{\partial x_{11}} & \frac{\partial p}{\partial x_{12}} & \frac{\partial p}{\partial x_{13}} \\ \frac{\partial p}{\partial x_{21}} & \frac{\partial p}{\partial x_{22}} & \frac{\partial p}{\partial x_{23}} \\ \frac{\partial p}{\partial x_{31}} & \frac{\partial p}{\partial x_{32}} & \frac{\partial p}{\partial x_{33}} \end{matrix} = \text{conv} \left(\begin{matrix} 0 & 0 & 0 & 0 \\ 0 & \frac{\partial p}{\partial y_{11}} & \frac{\partial p}{\partial y_{12}} & 0 \\ 0 & \frac{\partial p}{\partial y_{21}} & \frac{\partial p}{\partial y_{22}} & 0 \\ 0 & 0 & 0 & 0 \end{matrix}, \begin{matrix} w_{22} & w_{21} \\ w_{12} & w_{11} \end{matrix} \right)$$

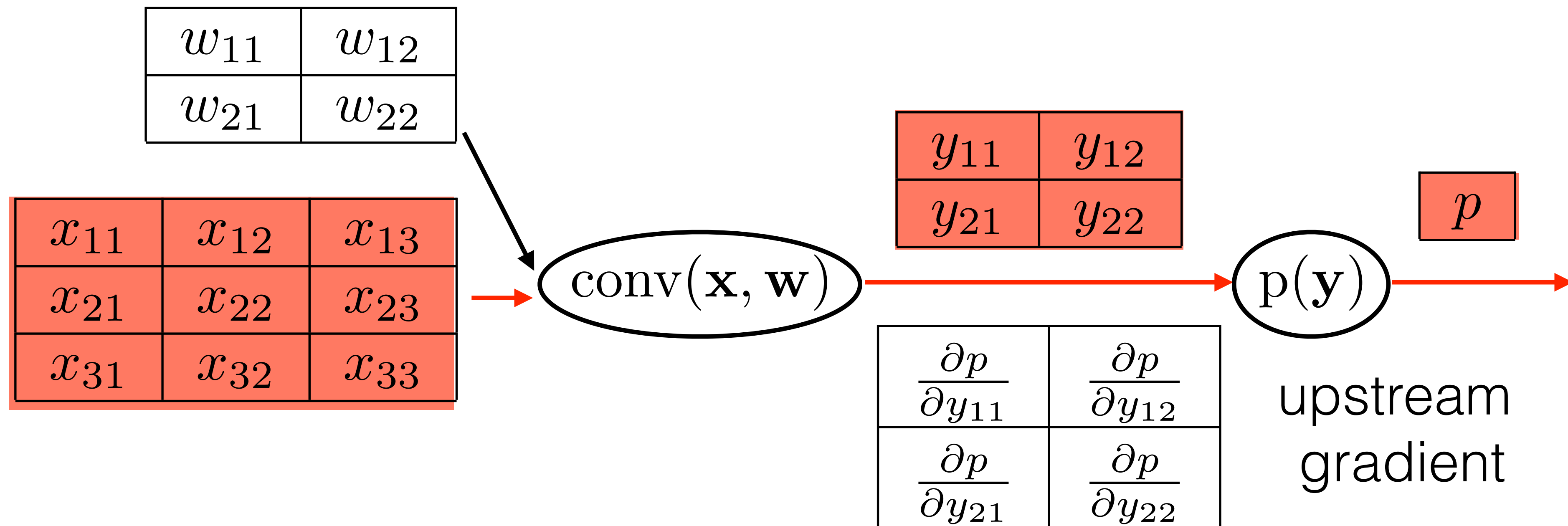

Convolution backward pass wrt input feature map

Very important property of convolutional layer is:

Backpropagation is also convolution !!!

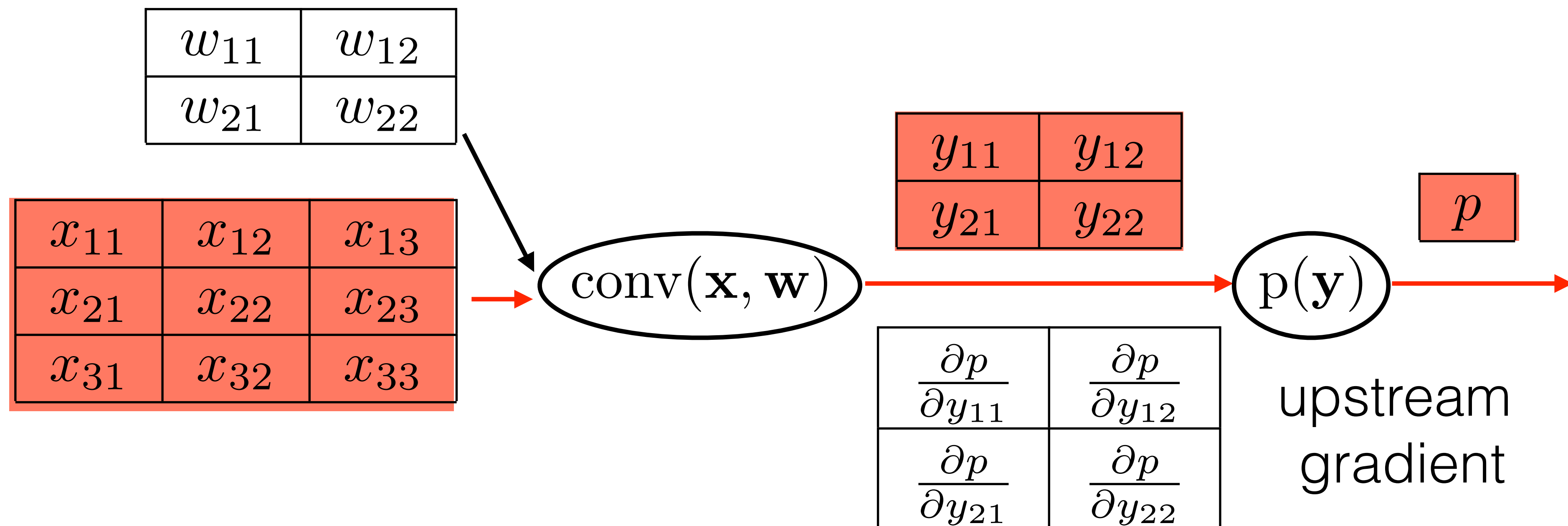

Activation functions

Sigmoid

$$\sigma(x) = \frac{1}{1+e^{-x}}$$

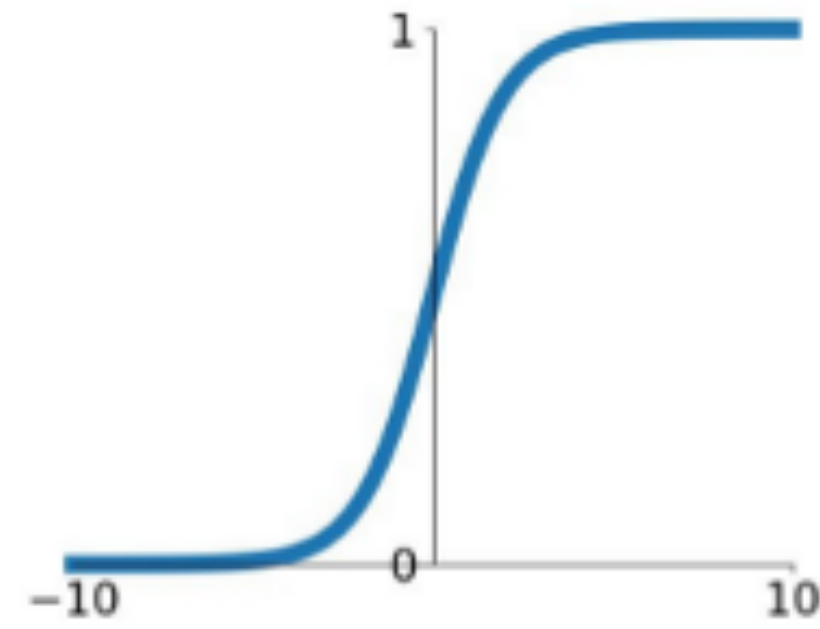

tanh

$$\tanh(x)$$

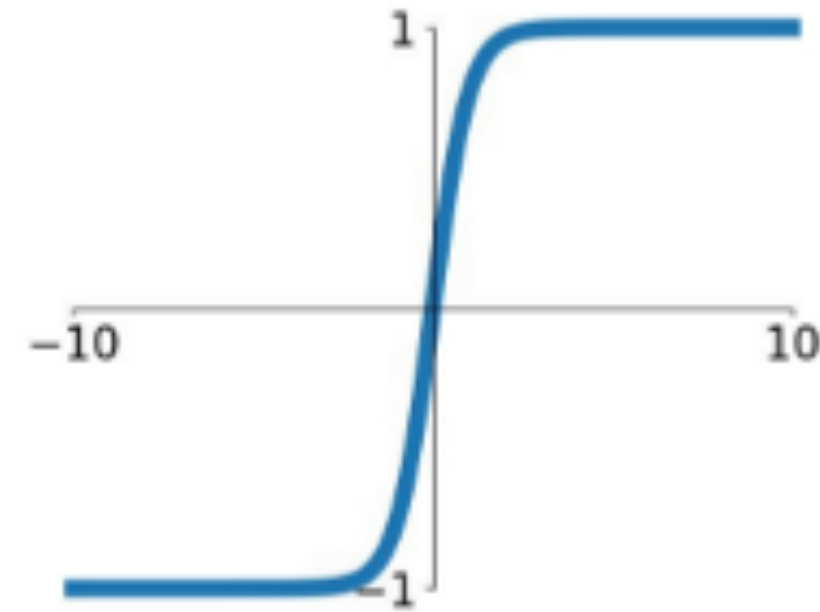

ReLU

$$\max(0, x)$$

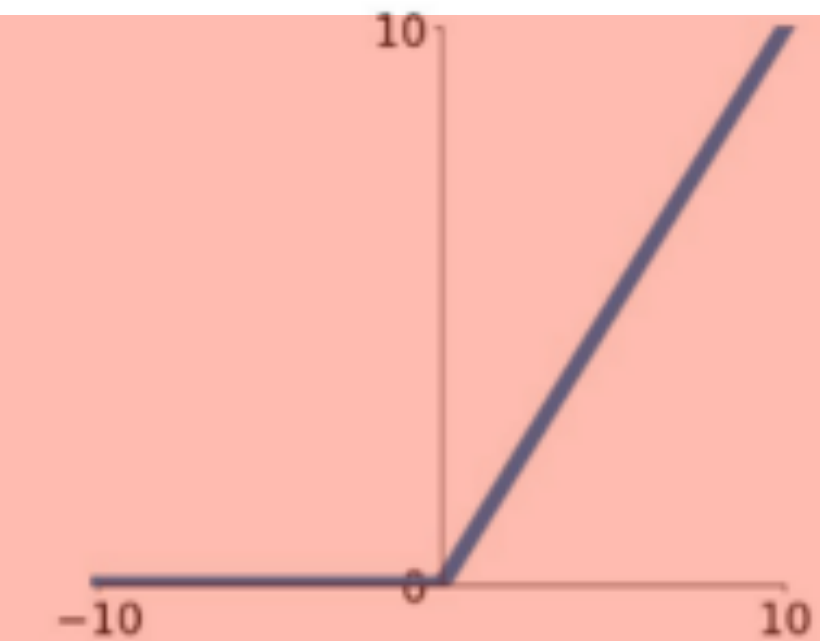

Leaky ReLU

$$\max(0.1x, x)$$

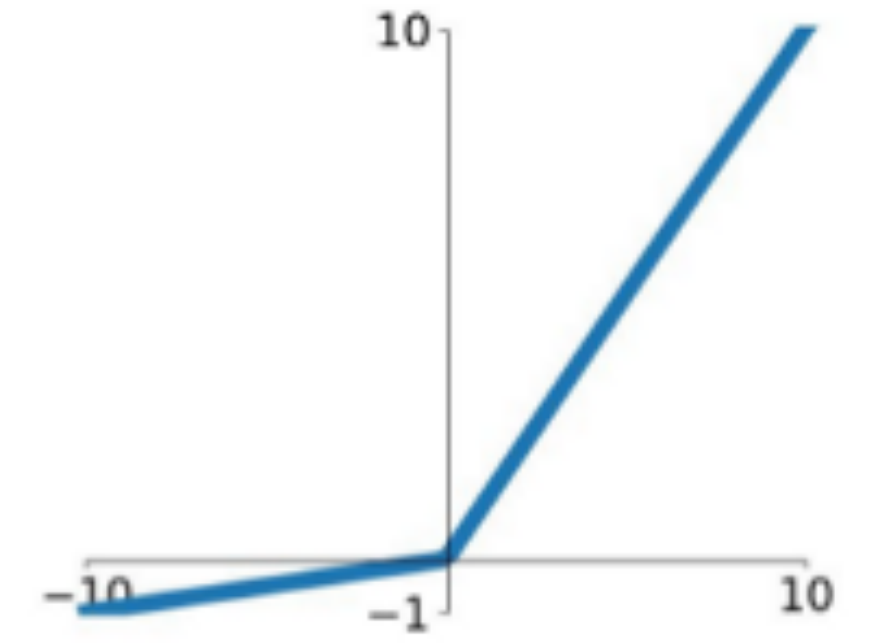

Maxout

$$\max(w_1^T x + b_1, w_2^T x + b_2)$$

ELU

$$\begin{cases} x & x \geq 0 \\ \alpha(e^x - 1) & x < 0 \end{cases}$$

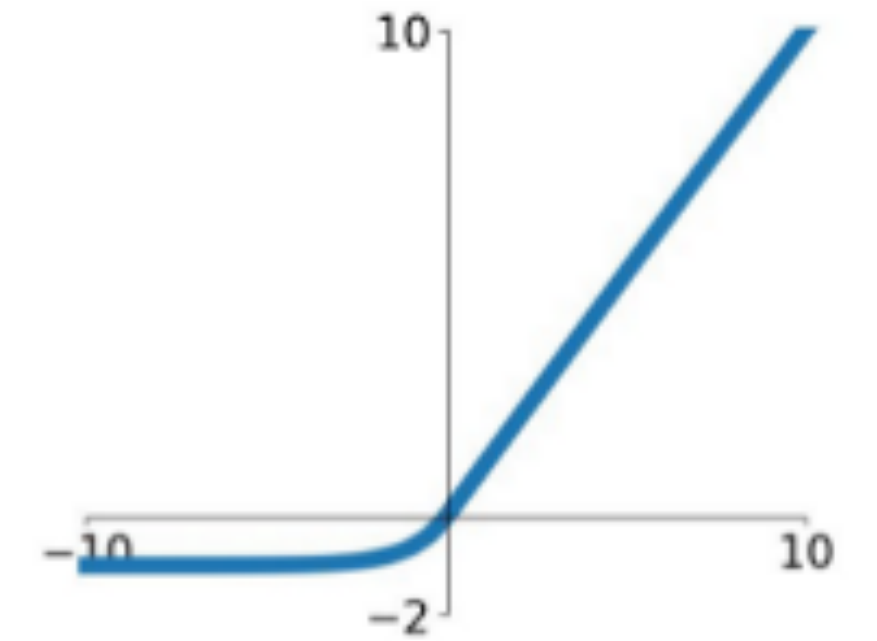

Max-pooling

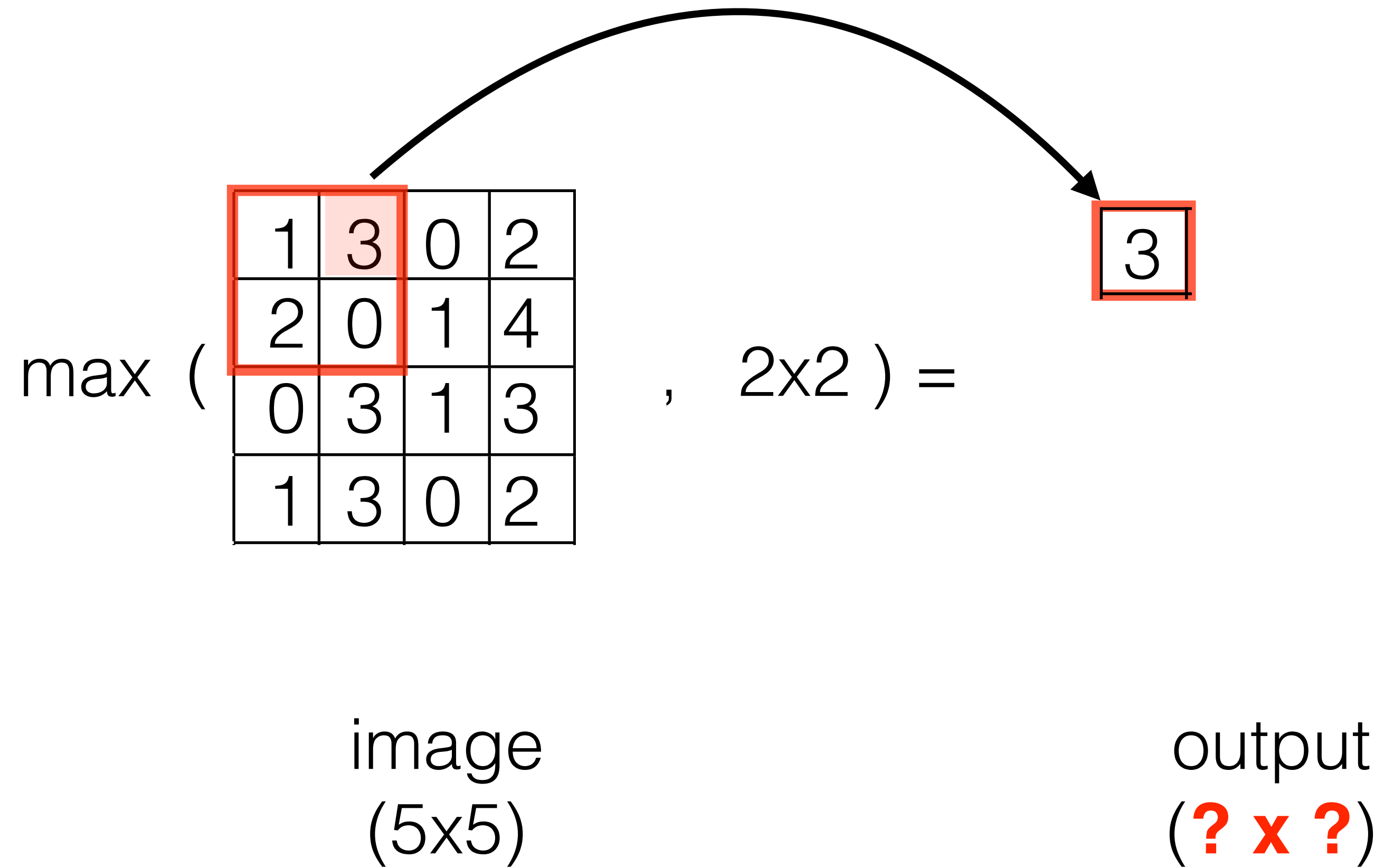

Max-pooling

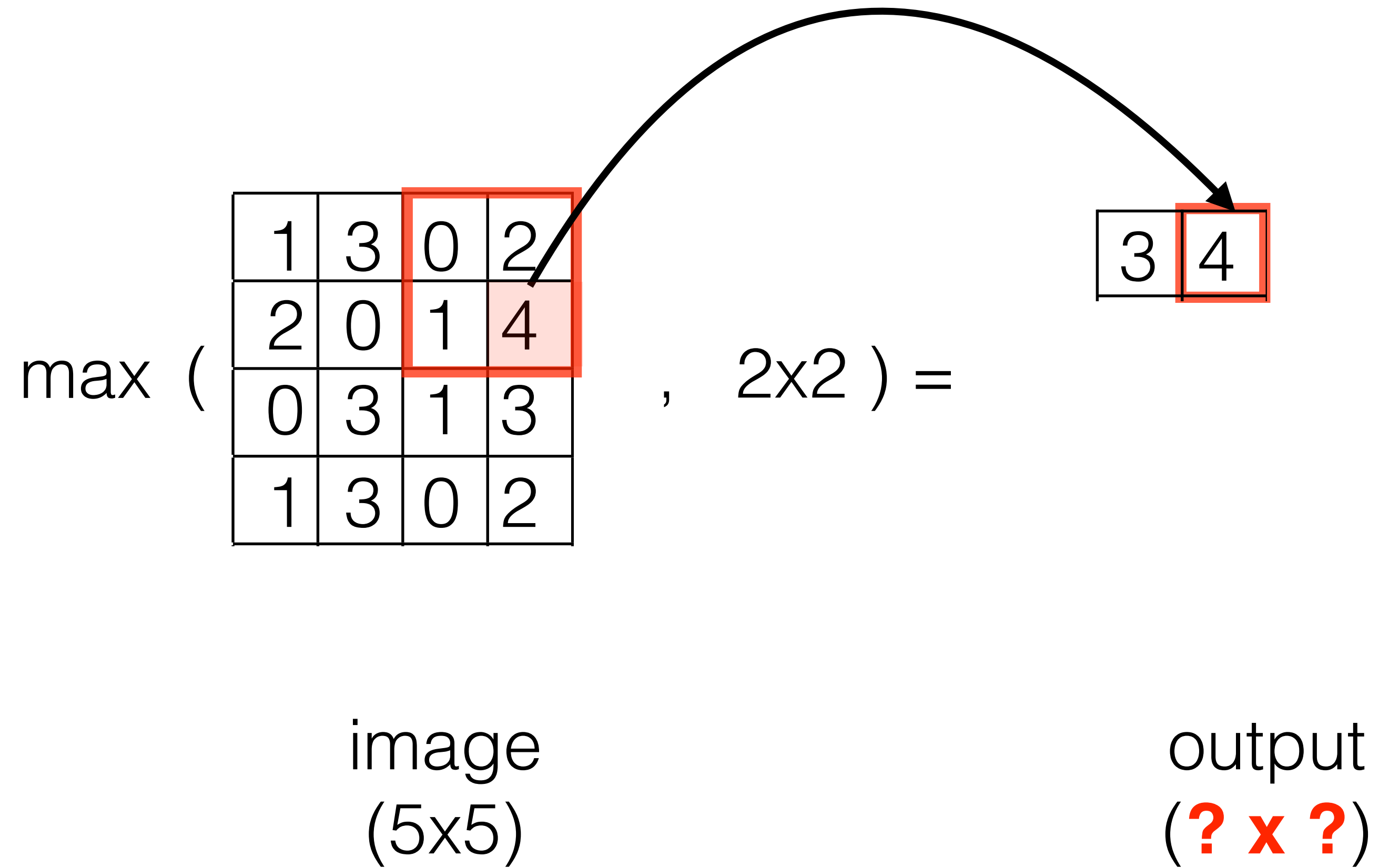

Max-pooling

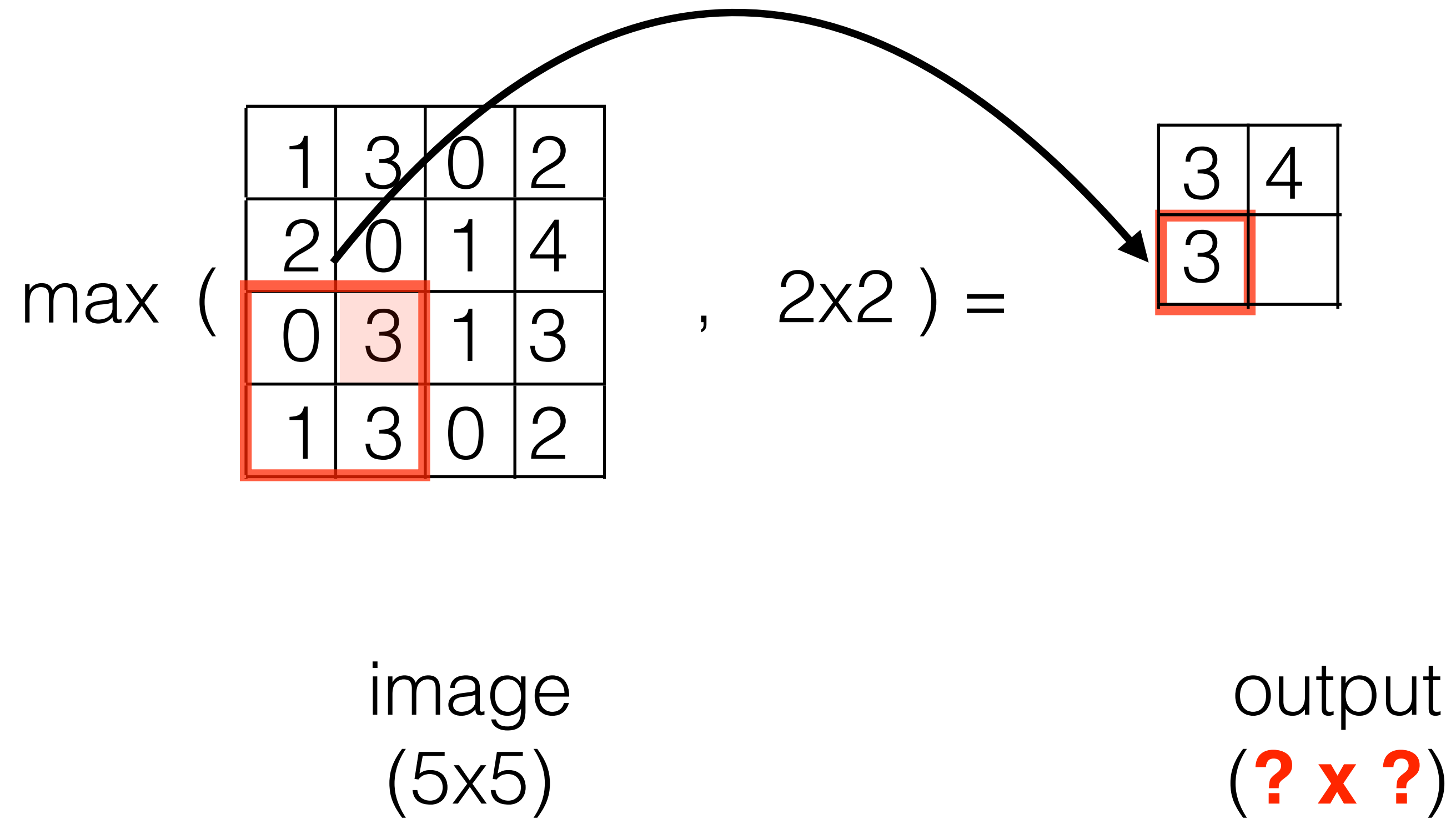

Max-pooling

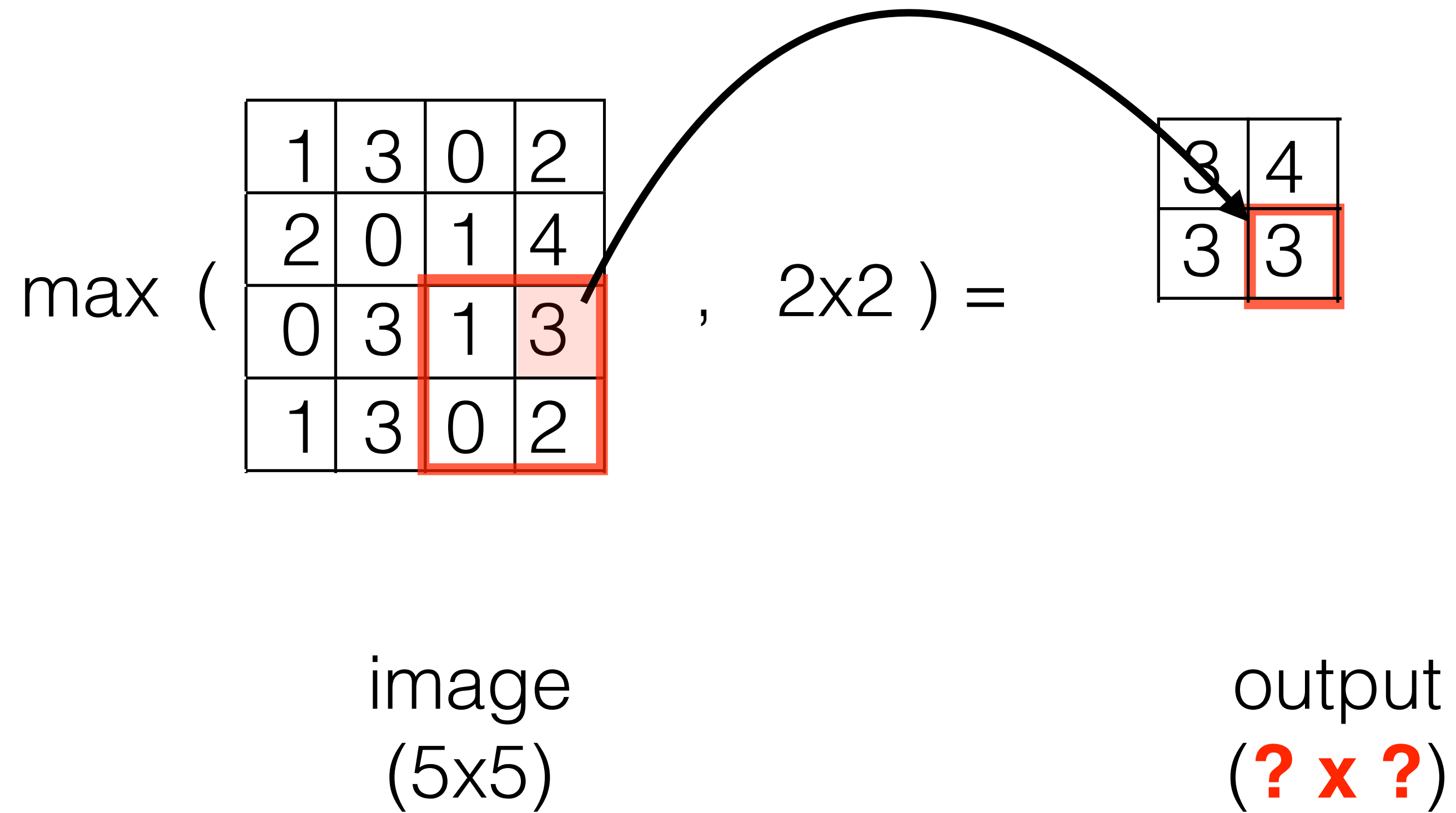

Learning of a simple convolutional network
input 3D tensor: channels x height x width

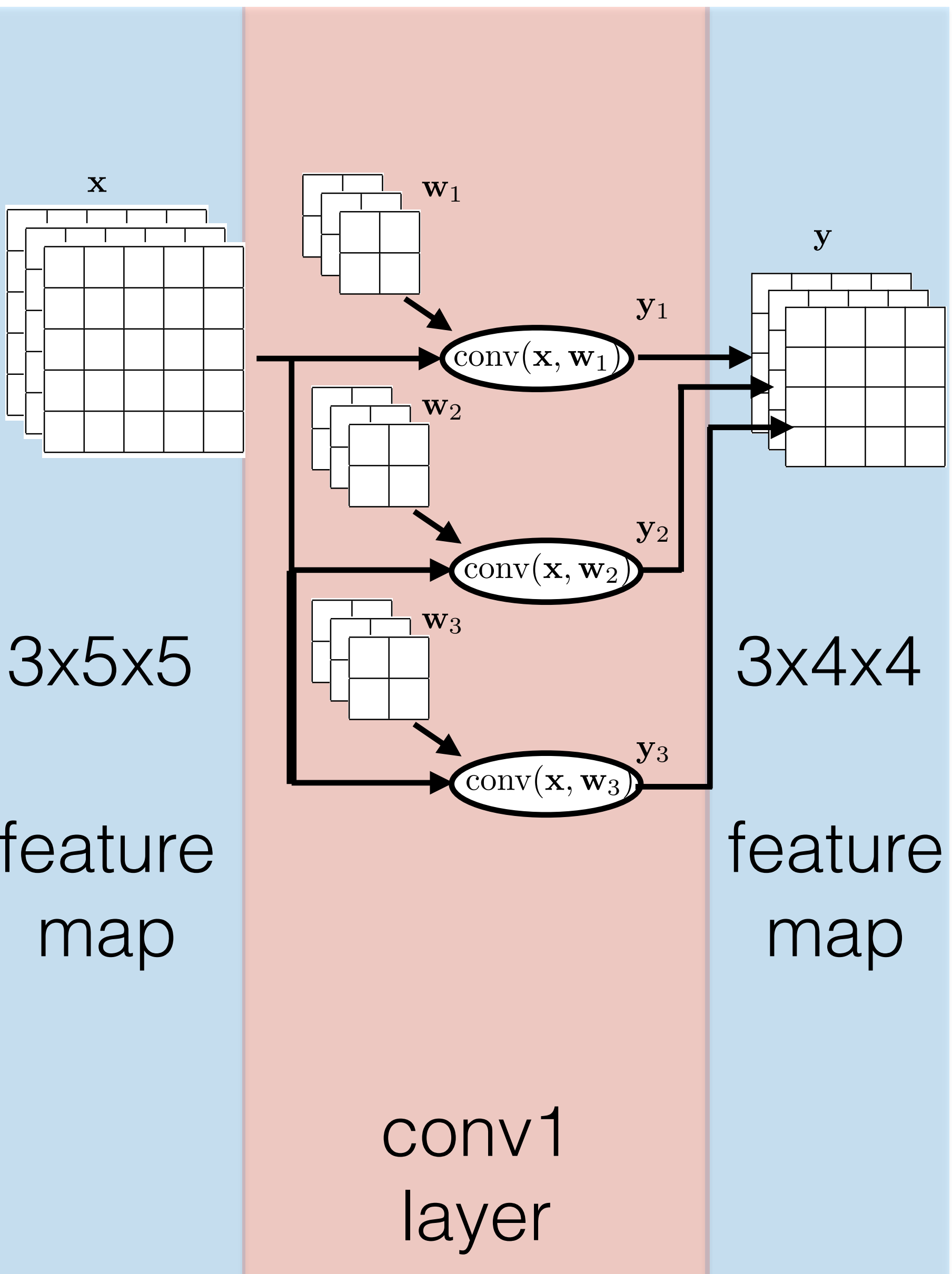

Learning of a simple convolutional network

input 3D tensor: channels x height x width

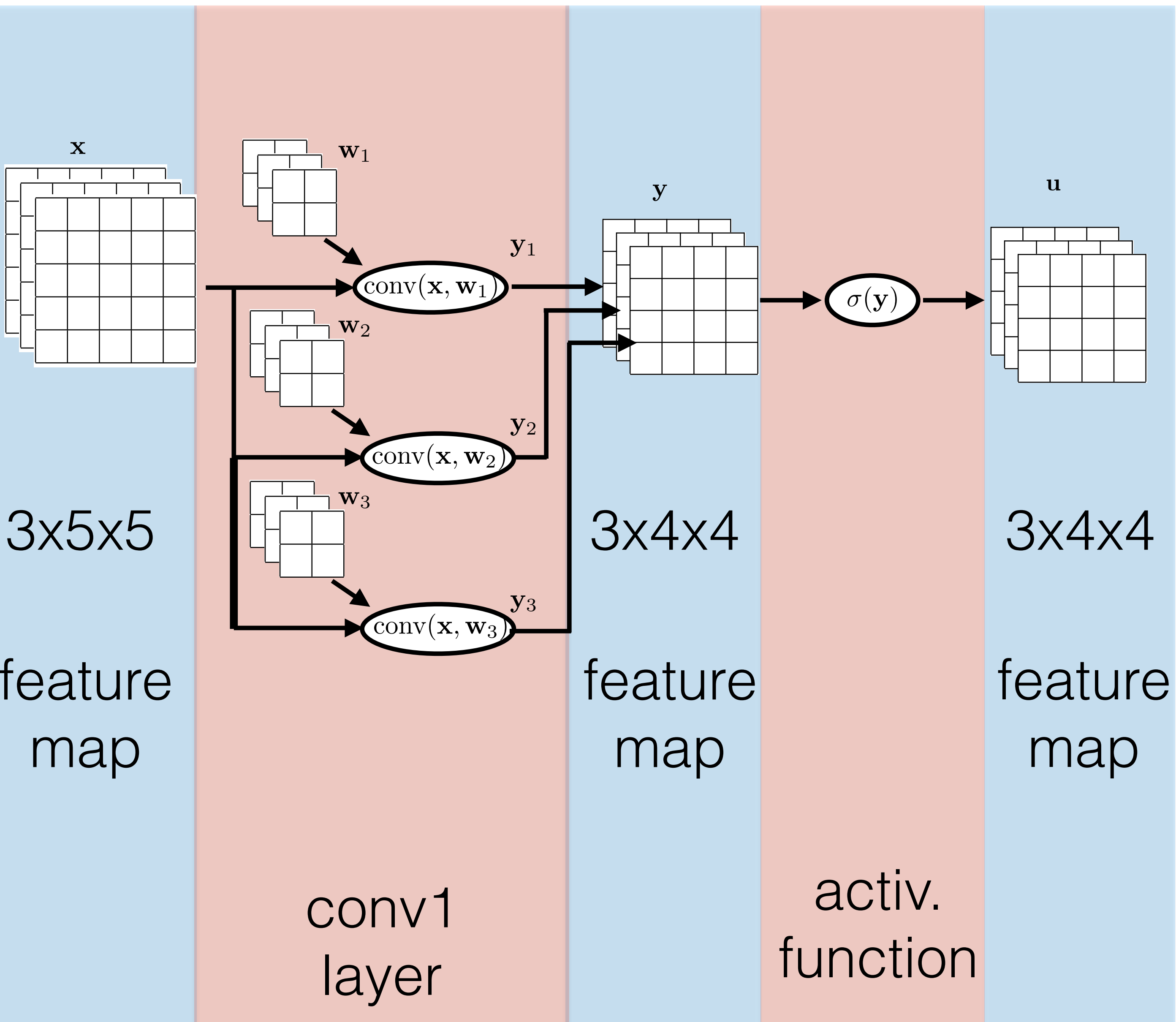

Learning of a simple convolutional network

input 3D tensor: channels x height x width

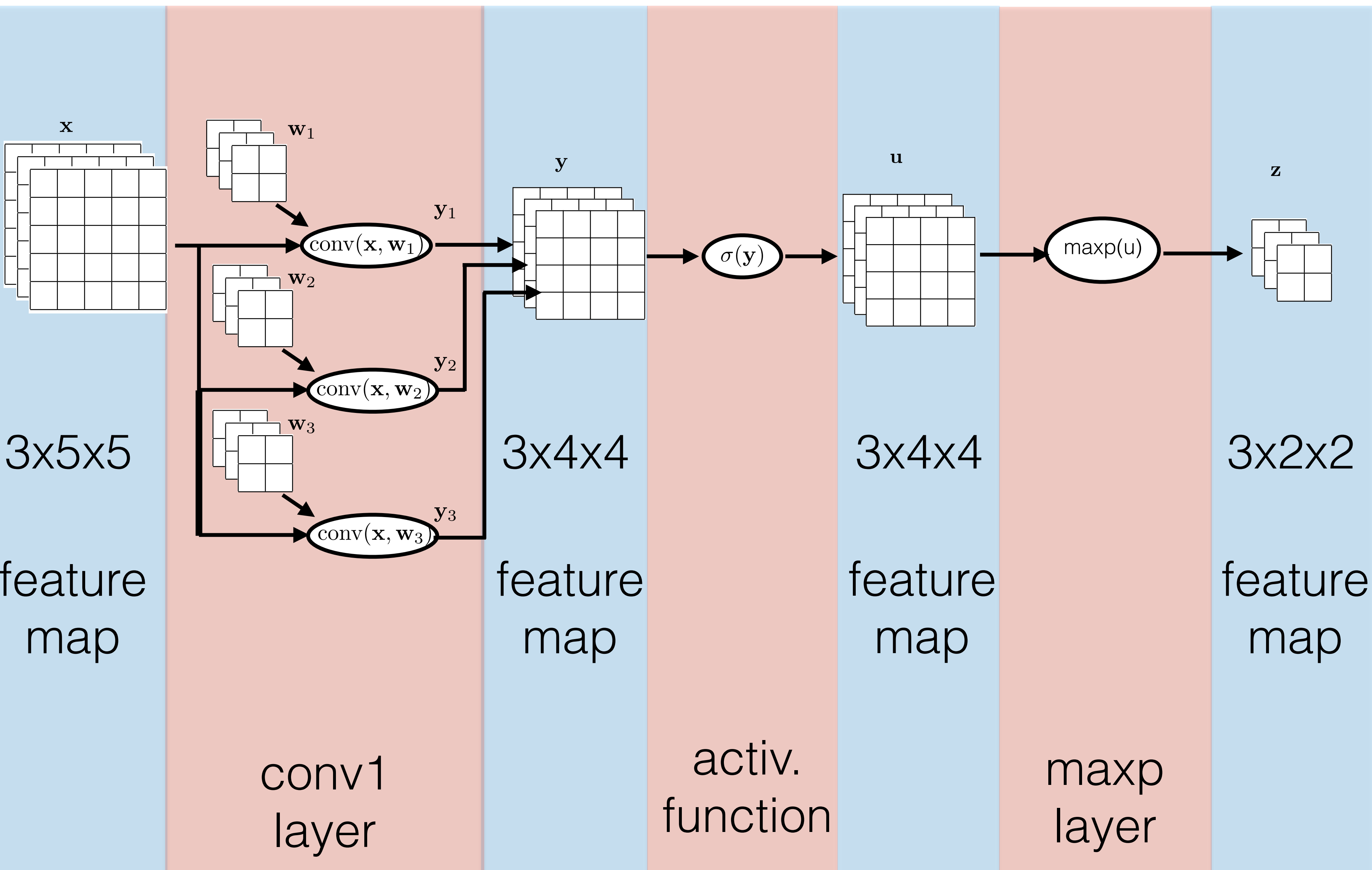

Learning of a simple convolutional network

input 3D tensor: channels x height x width

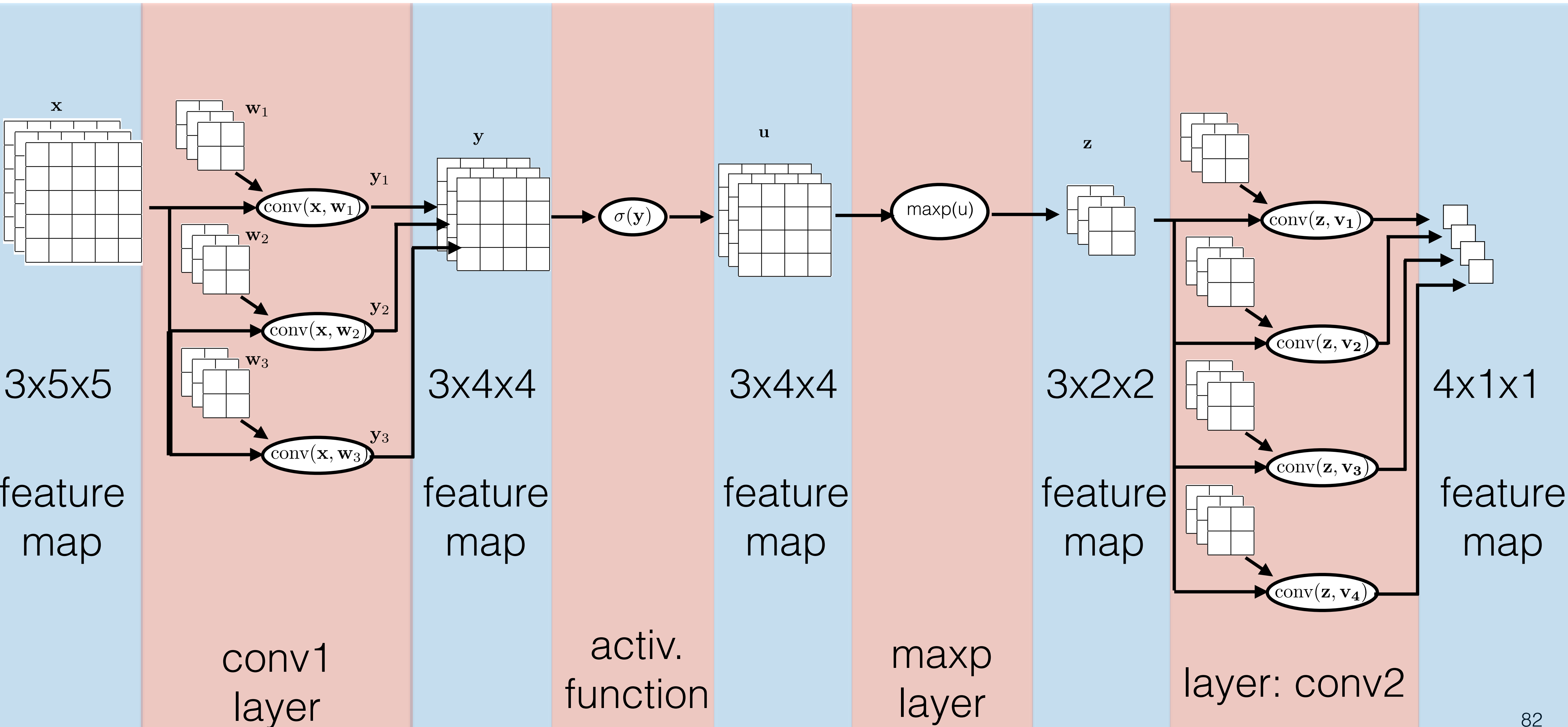

Learning of a simple convolutional network

input 3D tensor: channels x height x width

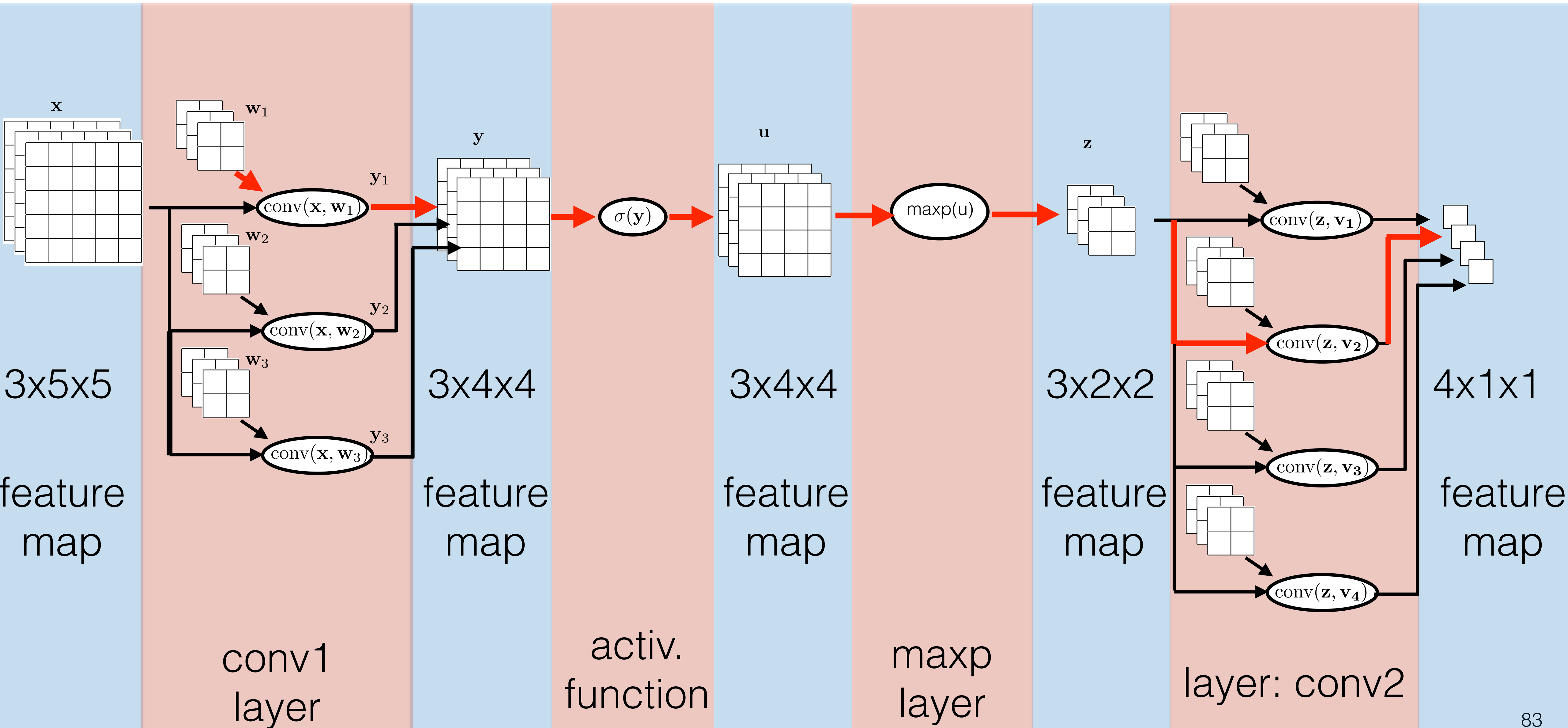

Learning with mini-batches

input 4D tensor: batch_size x channels x height x width

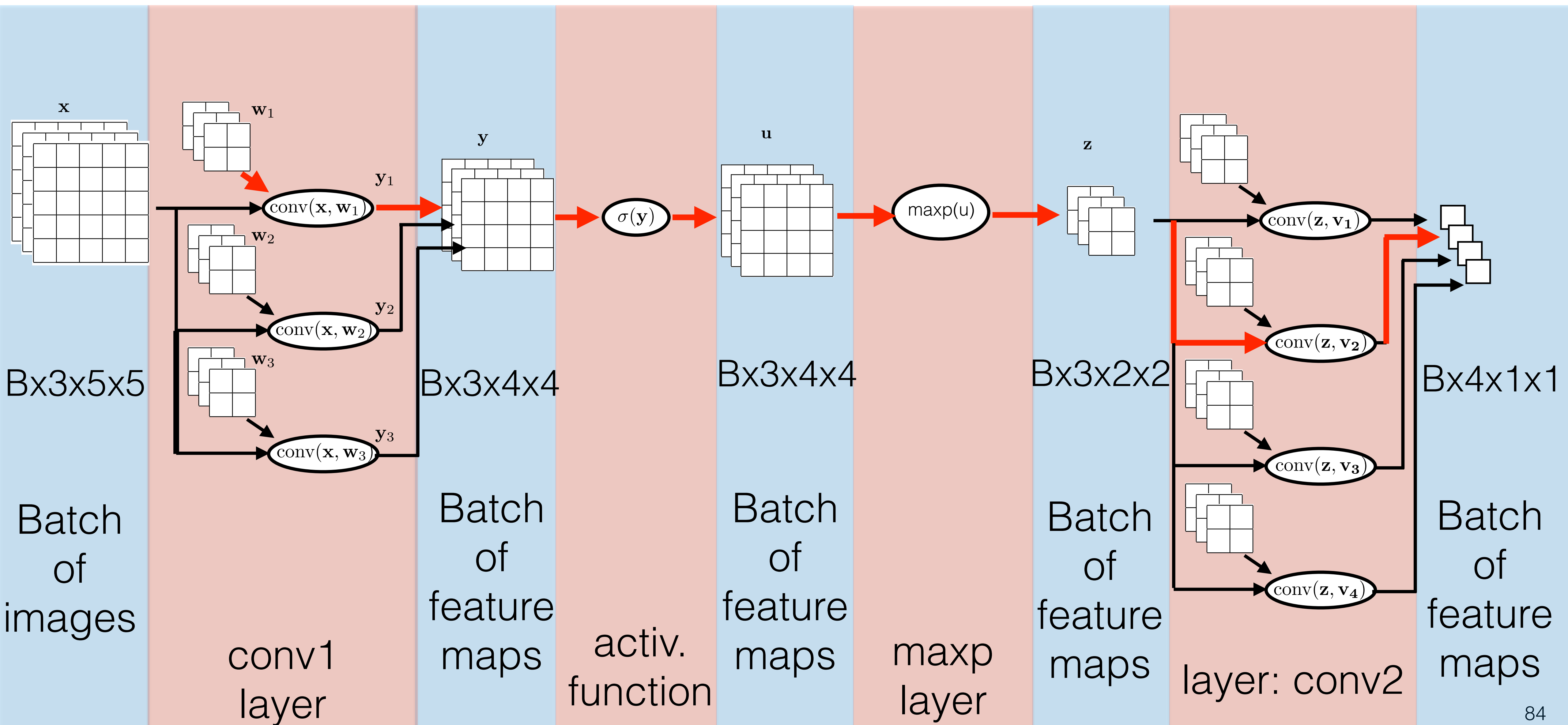

Convolutional net

- **Convolutional network** (ConvNet) is concatenation of convolutional layers, activation function and optionally max-pooling functions.
- **Backprop in convolutional layer** is convolution of feature maps or kernels or feature-maps with the upstream gradient.
- Feed-forward and backprop are convolutions => efficient implementation on GPU

LeCun's letter recognition 1998 (over 13k citations !!!)

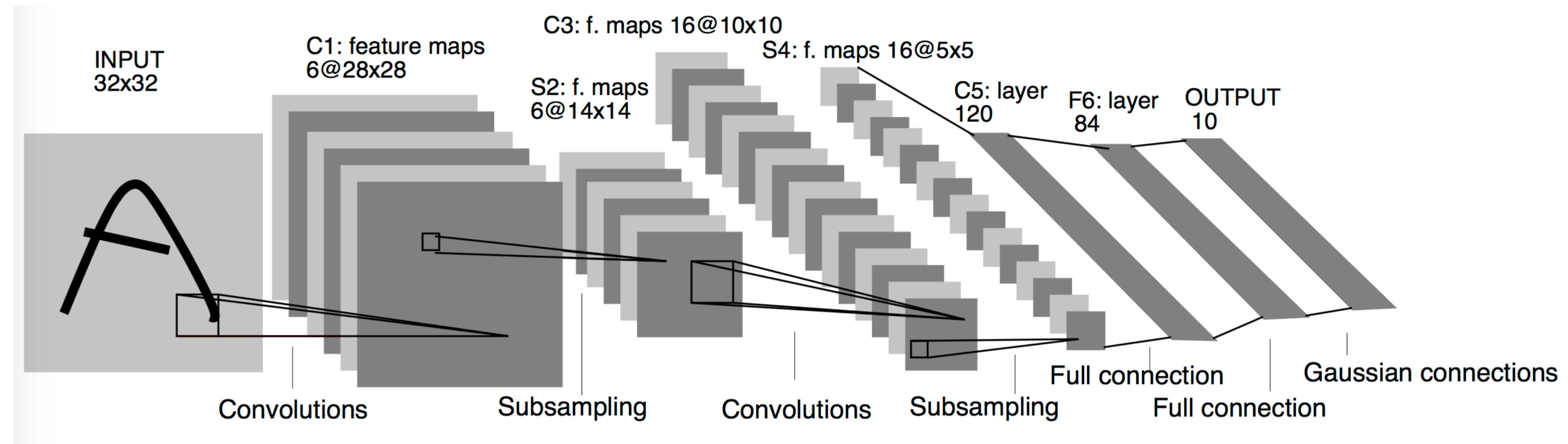

LeCun et al, Gradient based learning applied to document recognition, IEEE, 1998
<http://yann.lecun.com/exdb/publis/pdf/lecun-01a.pdf>

AlexNet on ImageNet 2012 (**over 27k citations !!!**)

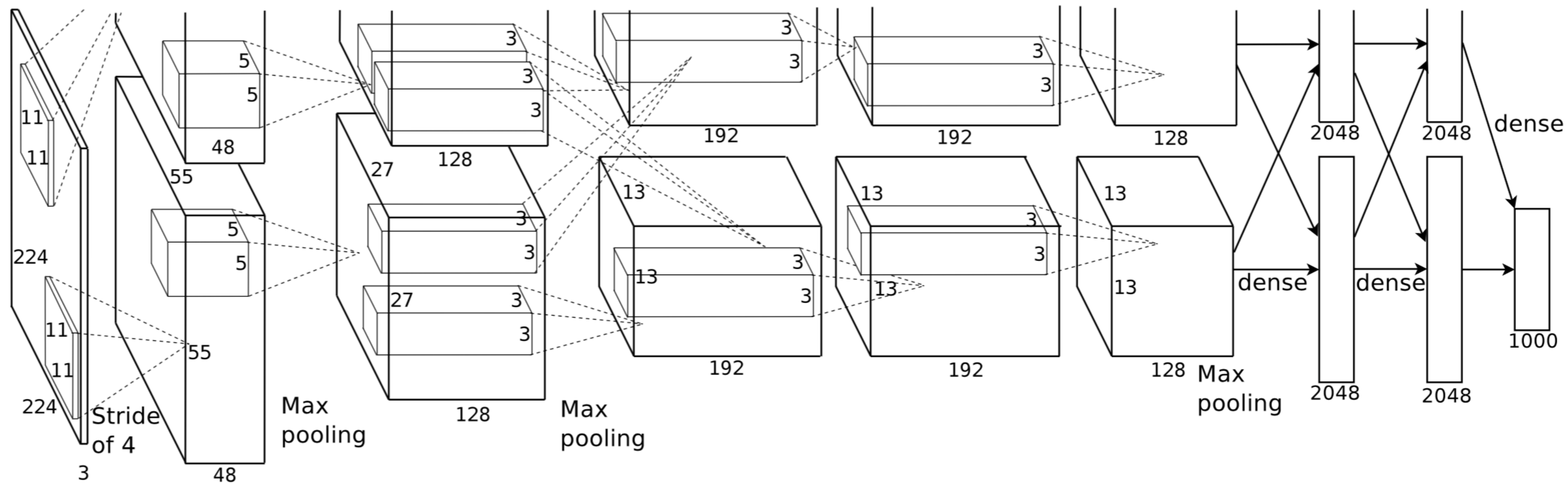

Alex Krizhevsky et al, Imagenet classification with deep convolutional neural networks, NIPS, 2012

<https://papers.nips.cc/paper/4824-imagenet-classification-with-deep-convolutional-neural-networks.pdf>

Classification results

<http://image-net.org/challenges/LSVRC/2017/index>

Steel drum



Output:
Scale
T-shirt
Steel drum
Drumstick
Mud turtle



Output:
Scale
T-shirt
Giant panda
Drumstick
Mud turtle



$$\text{Error} = \frac{1}{100,000} \sum_{100,000 \text{ images}} 1[\text{incorrect on image } i]$$

Classification results

AlexNet

8 layers

VGGnet

19 layers

GoogLeNet

22 layers

ResNet

152 layers

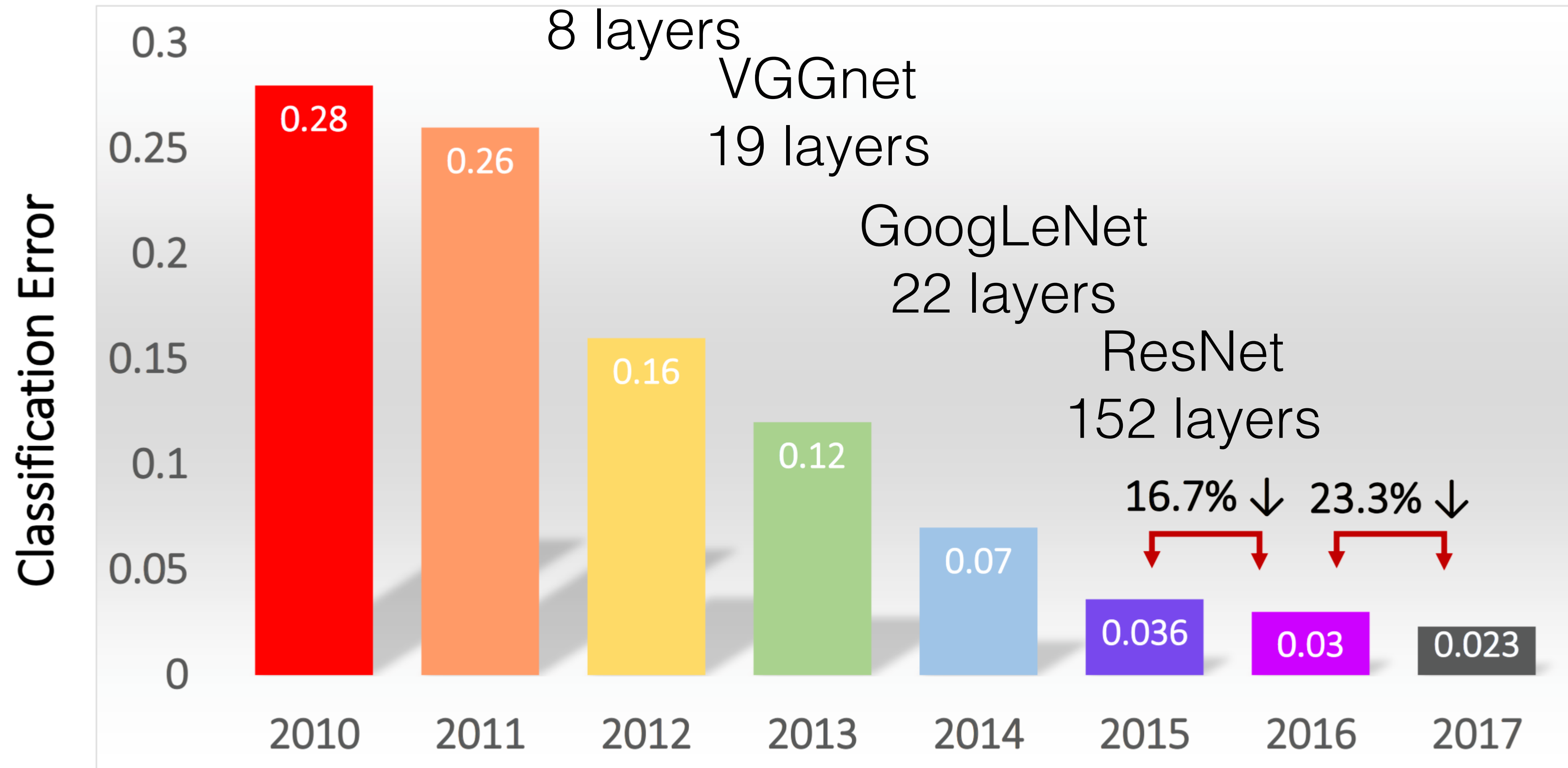

Pascal VOC object detection challenge

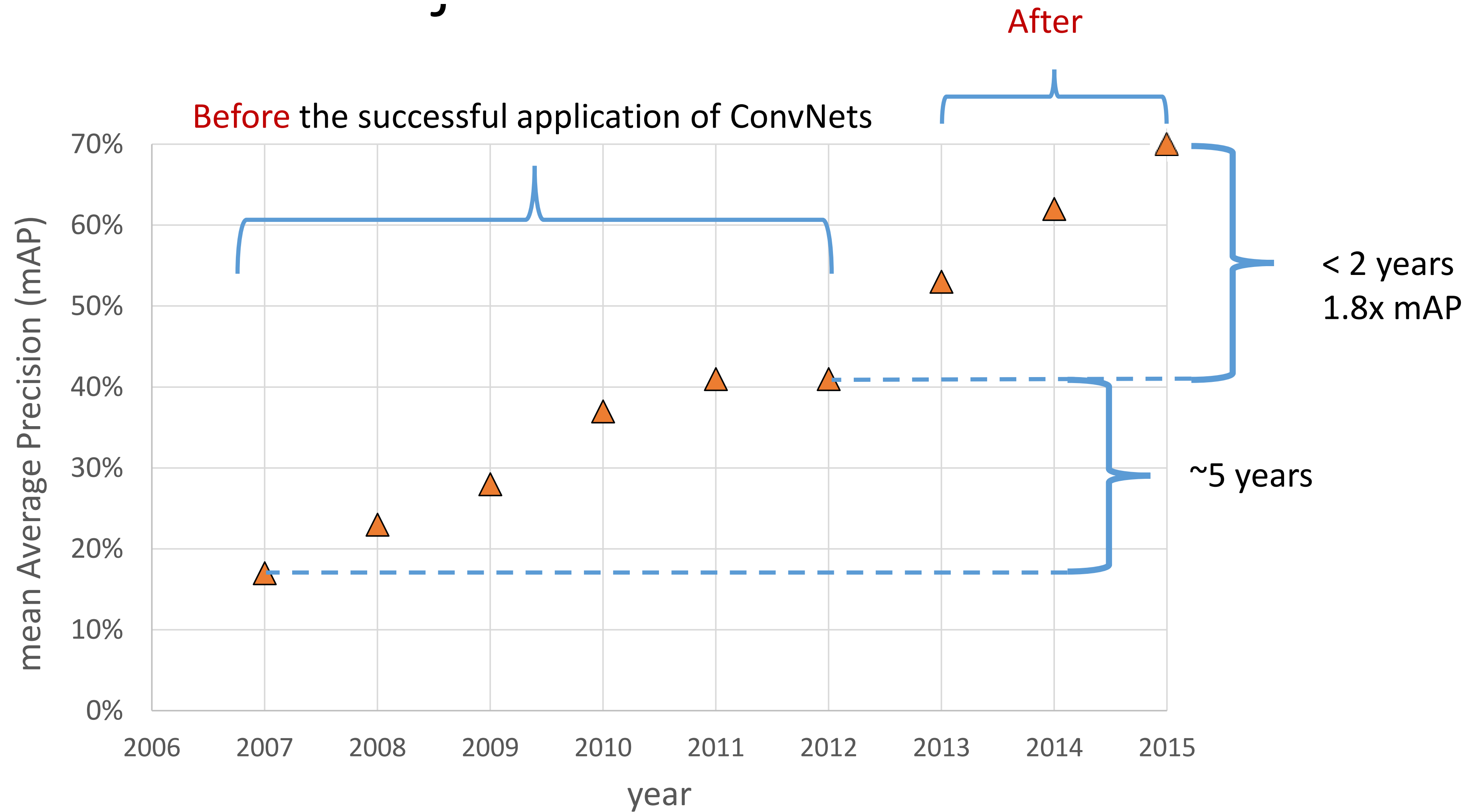

Test competencies

- ConvNet/Layer feed-forward pass
- ConvNet/Layer backpropagation

Next lecture

- gradient learning (what makes it tough)
- other layers:
 - deconvolution layer
 - activation function, maxpool,
 - batch normalization,
 - drop out,
 - loss layers