

# 3D Computer Vision

Radim Šára    Martin Matoušek

Center for Machine Perception  
Department of Cybernetics  
Faculty of Electrical Engineering  
Czech Technical University in Prague

<https://cw.fel.cvut.cz/wiki/courses/tdv/start>

<http://cmp.felk.cvut.cz>

<mailto:sara@cmp.felk.cvut.cz>

phone ext. 7203

rev. December 13, 2022



Open Informatics Master's Course

## Perspective Camera

- 2.1 Basic Entities: Points, Lines
- 2.2 Homography: Mapping Acting on Points and Lines
- 2.3 Canonical Perspective Camera
- 2.4 Changing the Outer and Inner Reference Frames
- 2.5 Projection Matrix Decomposition
- 2.6 Anatomy of Linear Perspective Camera
- 2.7 Vanishing Points and Lines

**covered by**

[H&Z] Secs: 2.1, 2.2, 3.1, 6.1, 6.2, 8.6, 2.5, Example: 2.19

## ► Basic Geometric Entities, their Representation, and Notation

- entities have names and representations
- names and their components:

entity	in 2-space	in 3-space
point	$m = (u, v)$	$X = (x, y, z)$
line	$n$	$O$
plane		$\pi, \varphi$

- associated vector representations

$$\mathbf{m} = \begin{bmatrix} u \\ v \end{bmatrix} = [u, v]^T, \quad \mathbf{X} = \begin{bmatrix} x \\ y \\ z \end{bmatrix}, \quad \mathbf{n}$$

will also be written in an 'in-line' form as  $\mathbf{m} = (u, v)$ ,  $\mathbf{X} = (x, y, z)$ , etc.

- vectors are always meant to be columns  $\mathbf{x} \in \mathbb{R}^{n \times 1}$
- associated homogeneous representations

$$\underline{\mathbf{m}} = [m_1, m_2, m_3]^T, \quad \underline{\mathbf{X}} = [x_1, x_2, x_3, x_4]^T, \quad \underline{\mathbf{n}}$$

'in-line' forms:  $\underline{\mathbf{m}} = (m_1, m_2, m_3)$ ,  $\underline{\mathbf{X}} = (x_1, x_2, x_3, x_4)$ , etc.

- matrices are  $\mathbf{Q} \in \mathbb{R}^{m \times n}$ , linear map of a  $\mathbb{R}^{n \times 1}$  vector is  $\mathbf{y} = \mathbf{Q}\mathbf{x}$
- $j$ -th element of vector  $\mathbf{m}_i$  is  $(\mathbf{m}_i)_j$ ; element  $i, j$  of matrix  $\mathbf{P}$  is  $\mathbf{P}_{ij}$

## ► Image Line (in 2D)

a finite line in the 2D  $(u, v)$  plane

$$(u, v) \in \mathbb{R}^2 \quad \text{s.t.} \quad a u + b v + c = 0$$

has a parameter (homogeneous) vector

$$\underline{\mathbf{n}} \simeq (a, b, c), \quad \|\underline{\mathbf{n}}\| \neq 0$$

and there is an equivalence class for  $\lambda \in \mathbb{R}, \lambda \neq 0$   $(\lambda a, \lambda b, \lambda c) \simeq (a, b, c)$

### 'Finite' lines

- standard representative for finite  $\underline{\mathbf{n}} = (n_1, n_2, n_3)$  is  $\lambda \underline{\mathbf{n}}$ , where  $\lambda = \frac{\mathbf{1}}{\sqrt{n_1^2 + n_2^2}}$   
assuming  $n_1^2 + n_2^2 \neq 0$ ;  $\mathbf{1}$  is the unit, usually  $\mathbf{1} = 1$

### 'Infinite' line

- we augment the set of lines for a special entity called the **line at infinity** (ideal line)

$$\underline{\mathbf{n}}_\infty \simeq (0, 0, \mathbf{1}) \quad (\text{standard representative})$$

- the set of equivalence classes of vectors in  $\mathbb{R}^3 \setminus (0, 0, 0)$  forms the projective space  $\mathbb{P}^2$  a set of rays  $\rightarrow 21$
- line at infinity is a proper member of  $\mathbb{P}^2$
- I may sometimes wrongly use  $=$  instead of  $\simeq$ , if you are in doubt, ask me

## ► Image Point

Finite point  $\mathbf{m} = (u, v)$  is incident on a finite line  $\underline{\mathbf{n}} = (a, b, c)$  iff

iff = works either way!

$$a u + b v + c = 0$$

can be rewritten as (with scalar product):  $(u, v, \mathbf{1}) \cdot (a, b, c) = \underline{\mathbf{m}}^\top \underline{\mathbf{n}} = 0$

### 'Finite' points

- a finite point is also represented by a homogeneous vector  $\underline{\mathbf{m}} \simeq (u, v, \mathbf{1})$ ,  $\|\underline{\mathbf{m}}\| \neq 0$
- the equivalence class for  $\lambda \in \mathbb{R}, \lambda \neq 0$  is  $(m_1, m_2, m_3) = \lambda \underline{\mathbf{m}} \simeq \underline{\mathbf{m}}$
- the standard representative for finite point  $\underline{\mathbf{m}}$  is  $\lambda \underline{\mathbf{m}}$ , where  $\lambda = \frac{1}{m_3}$  assuming  $m_3 \neq 0$
- when  $\mathbf{1} = 1$  then units are pixels and  $\lambda \underline{\mathbf{m}} = (u, v, 1)$
- when  $\mathbf{1} = f$  then all elements have a similar magnitude,  $f \sim$  image diagonal

use  $\mathbf{1} = 1$  unless you know what you are doing;

all entities participating in a formula must be expressed in the same units

### 'Infinite' points

- we augment for **points at infinity** (ideal points)  $\underline{\mathbf{m}}_\infty \simeq (m_1, m_2, 0)$  proper members of  $\mathbb{P}^2$
- all such points lie on the line at infinity (ideal line)  $\underline{\mathbf{n}}_\infty \simeq (0, 0, 1)$ , i.e.  $\underline{\mathbf{m}}_\infty^\top \underline{\mathbf{n}}_\infty = 0$

## ► Line Intersection and Point Join

The point of **intersection**  $m$  of image lines  $n$  and  $n'$ ,  $n \neq n'$  is

$$\underline{m} \simeq \underline{n} \times \underline{n}'$$

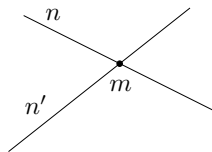

**proof:** If  $\underline{m} = \underline{n} \times \underline{n}'$  is the intersection point, it must be incident on both lines. Indeed, using known equivalences from vector algebra

$$\underline{n}^\top \underbrace{(\underline{n} \times \underline{n}')}_{\underline{m}} \equiv \underline{n}'^\top \underbrace{(\underline{n} \times \underline{n}')}_{\underline{m}} \equiv 0$$

The **join**  $n$  of two image points  $m$  and  $m'$ ,  $m \neq m'$  is

$$\underline{n} \simeq \underline{m} \times \underline{m}'$$

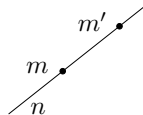

Parallel lines intersect (somewhere) on the line at infinity  $\underline{n}_\infty \simeq (0, 0, 1)$ :

$$a u + b v + c = 0,$$

$$a u + b v + d = 0,$$

$$d \neq c$$

$$(a, b, c) \times (a, b, d) \simeq (b, -a, 0)$$

- all such intersections lie on  $\underline{n}_\infty$
- line at infinity therefore represents the set of (unoriented) directions in the plane
- Matlab: `m = cross(n, n_prime);`

## ► Homography in $\mathbb{P}^2$

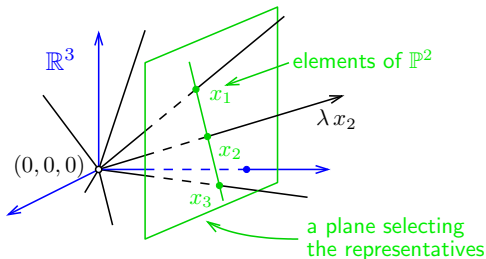

Projective plane  $\mathbb{P}^2$ : Vector space of dimension 3 excluding the zero vector,  $\mathbb{R}^3 \setminus (0,0,0)$ , factorized to linear equivalence classes ('rays'),  $\underline{x} \simeq \lambda \underline{x}$ ,  $\lambda \neq 0$  including 'points at infinity'

we call  $\underline{x} \in \mathbb{P}^2$  'points'

**Homography in  $\mathbb{P}^2$ :** Non-singular linear mapping in  $\mathbb{P}^2$

an analogic definition for  $\mathbb{P}^3$

$$\underline{x}' \simeq \mathbf{H} \underline{x}, \quad \mathbf{H} \in \mathbb{R}^{3,3} \text{ non-singular}$$

### Defining properties

- collinear points are mapped to collinear points
- concurrent lines are mapped to concurrent lines
- and point-line incidence is preserved

lines of points are mapped to lines of points

concurrent = intersecting at a point

e.g. line intersection points mapped to line intersection points

- $\mathbf{H}$  is a  $3 \times 3$  non-singular matrix,  $\lambda \mathbf{H} \simeq \mathbf{H}$  equivalence class, 8 degrees of freedom
- homogeneous matrix representative:  $\det \mathbf{H} = 1$
- what we call homography here is often called 'projective collineation' in mathematics

$$\mathbf{H} \in \text{SL}(3)$$

## ► Mapping 2D Points and Lines by Homography

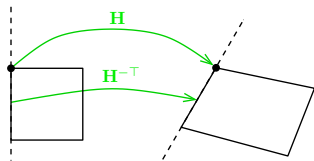

$$\underline{\mathbf{m}}' \simeq \mathbf{H} \underline{\mathbf{m}} \quad (\text{image point})$$

$$\underline{\mathbf{n}}' \simeq \mathbf{H}^{-\top} \underline{\mathbf{n}} \quad (\text{image line})$$

$$\mathbf{H}^{-\top} = (\mathbf{H}^{-1})^{\top} = (\mathbf{H}^{\top})^{-1}$$

- incidence is preserved:  $(\underline{\mathbf{m}}')^{\top} \underline{\mathbf{n}}' \simeq \underline{\mathbf{m}}^{\top} \mathbf{H}^{\top} \mathbf{H}^{-\top} \underline{\mathbf{n}} = \underline{\mathbf{m}}^{\top} \underline{\mathbf{n}} = 0$

Mapping a finite 2D point  $\mathbf{m} = (u, v)$  to  $\underline{\mathbf{m}} = (u', v')$

- extend the Cartesian (pixel) coordinates to homogeneous coordinates,  $\underline{\mathbf{m}} = (u, v, 1)$
- map by homography,  $\underline{\mathbf{m}}' = \mathbf{H} \underline{\mathbf{m}}$
- if  $m'_3 \neq 0$  convert the result  $\underline{\mathbf{m}}' = (m'_1, m'_2, m'_3)$  back to Cartesian coordinates (pixels),

$$u' = \frac{m'_1}{m'_3} \mathbf{1}, \quad v' = \frac{m'_2}{m'_3} \mathbf{1}$$

- note that, typically,  $m'_3 \neq 1$
- an infinite point  $\underline{\mathbf{m}} = (u, v, 0)$  maps the same way

$m'_3 = 1$  when  $\mathbf{H}$  is affine



# Some Homographic Tasters

**Rectification of camera rotation:** →59 (geometry), →129 (homography estimation)



$\mathbf{H} \simeq \mathbf{K} \mathbf{R}^T \mathbf{K}^{-1}$  maps from image plane to facade plane

**Homographic Mouse for Visual Odometry:** [Mallis 2007]



illustrations courtesy of AMSL Racing Team, Meiji University and LIBVISO: Library for VISual Odometry

$\mathbf{H} \simeq \mathbf{K} \left( \mathbf{R} - \frac{\mathbf{t} \mathbf{n}^T}{d} \right) \mathbf{K}^{-1}$  maps from plane to translated plane [H&Z, p. 327]

## ► Homography Subgroups: Euclidean Mapping (aka Rigid Motion)

- Euclidean mapping (EM): rotation, translation and their combination

$$\mathbf{H} = \begin{bmatrix} \cos \phi & -\sin \phi & t_x \\ \sin \phi & \cos \phi & t_y \\ 0 & 0 & 1 \end{bmatrix} = \begin{bmatrix} \mathbf{R} & \mathbf{t} \\ \mathbf{0}^\top & 1 \end{bmatrix} \in \text{SE}(2)$$

- note: action  $H(\mathbf{x}) = \mathbf{R}\mathbf{x} + \mathbf{t}: \mathbb{R}^2 \rightarrow \mathbb{R}^2$ , not commutative

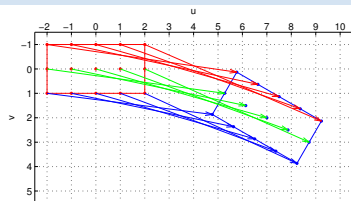

rotation by  $30^\circ$ , then translation by (7, 2)

### EM = The most general homography preserving

1. **lengths**: Let  $\mathbf{x}'_i = H(\mathbf{x}_i)$ . Then

$$\|\mathbf{x}'_2 - \mathbf{x}'_1\| = \|H(\mathbf{x}_2) - H(\mathbf{x}_1)\| = \dots = \|\mathbf{x}_2 - \mathbf{x}_1\|$$

\* P1; 1pt

2. **angles**

check the dot-product of normalized differences from a point  $(\mathbf{x} - \mathbf{z})^\top (\mathbf{y} - \mathbf{z})$  (Cartesian(!))

3. **areas**:  $\det \mathbf{H} = 1 \Rightarrow$  unit Jacobian; follows from 1. and 2.

- eigenvalues  $(1, e^{-i\phi}, e^{i\phi})$
- eigenvectors when  $\phi \neq k\pi, k = 0, 1, \dots$  (columnwise)

$$\mathbf{e}_1 \simeq \begin{bmatrix} t_x + t_y \cot \frac{\phi}{2} \\ t_y - t_x \cot \frac{\phi}{2} \\ 2 \end{bmatrix}, \quad \mathbf{e}_2 \simeq \begin{bmatrix} i \\ 1 \\ 0 \end{bmatrix}, \quad \mathbf{e}_3 \simeq \begin{bmatrix} -i \\ 1 \\ 0 \end{bmatrix}$$

$\mathbf{e}_2, \mathbf{e}_3$  – circular points,  $i$  – imaginary unit

4. **circular points**: complex points at infinity  $(i, 1, 0), (-i, 1, 0)$  (preserved even by similarity)

- **similarity**: scaled Euclidean mapping (does not preserve lengths, areas)

## ► Homography Subgroups: Affine Mapping (Affinity)

$$\mathbf{H} = \begin{bmatrix} a_{11} & a_{12} & t_x \\ a_{21} & a_{22} & t_y \\ 0 & 0 & 1 \end{bmatrix}$$

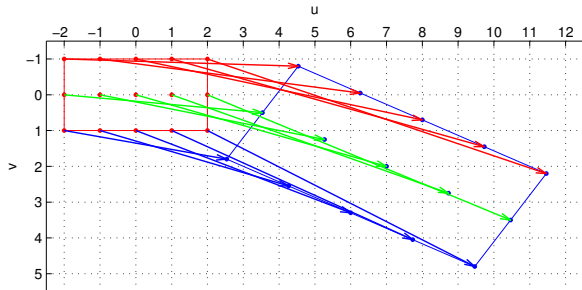

rotation by  $30^\circ$   
then scaling by  $\text{diag}(1, 1.5, 1)$   
then translation by  $(7, 2)$

### Affinity = The most general homography preserving

- parallelism
- ratio of areas
- ratio of lengths on parallel lines
- linear combinations of vectors (e.g. midpoints, centers of gravity)
- convex hull
- line at infinity  $\underline{n}_\infty$  (not pointwise)

$$\text{observe } \mathbf{H}^T \underline{n}_\infty \simeq \begin{bmatrix} a_{11} & a_{21} & 0 \\ a_{12} & a_{22} & 0 \\ t_x & t_y & 1 \end{bmatrix} \begin{bmatrix} 0 \\ 0 \\ 1 \end{bmatrix} = \begin{bmatrix} 0 \\ 0 \\ 1 \end{bmatrix} = \underline{n}_\infty \Rightarrow \underline{n}_\infty \simeq \mathbf{H}^{-T} \underline{n}_\infty$$

### does not preserve

- lengths
- angles
- areas
- circular points

## ► Homography Subgroups: General Homography

$$\mathbf{H} = \begin{bmatrix} h_{11} & h_{12} & h_{13} \\ h_{21} & h_{22} & h_{23} \\ h_{31} & h_{32} & h_{33} \end{bmatrix} \quad \mathbf{H} \in \text{SL}(3)$$

### preserves only

- incidence and concurrency
- collinearity
- cross-ratio (ratio of ratios) on the line  $\rightarrow 46$

### does not preserve

- lengths
- areas
- parallelism
- ratio of areas
- ratio of lengths
- linear combinations of vectors
- convex hull
- line at infinity  $\underline{n}_\infty$

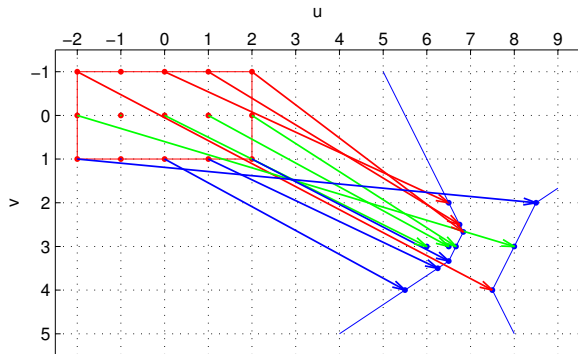

$$\mathbf{H} = \begin{bmatrix} 7 & -0.5 & 6 \\ 3 & 1 & 3 \\ 1 & 0 & 1 \end{bmatrix}$$

line  $\underline{n} = (1, 0, 1)$  is mapped to  $\underline{n}_\infty$ :  $\mathbf{H}^{-T} \underline{n} \simeq \underline{n}_\infty$

(where in the picture is the line  $n$ ?)

## ► Canonical Perspective Camera (Pinhole Camera, Camera Obscura)

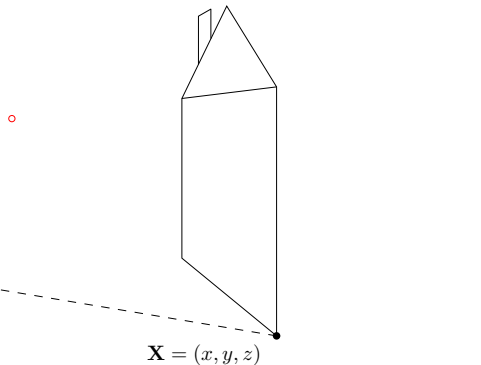
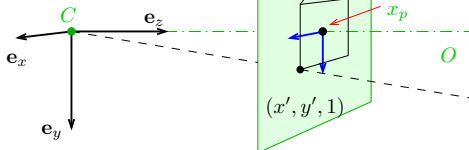
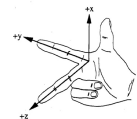

1. in this picture we are looking 'down the street'
2. right-handed canonical coordinate system  $(x, y, z)$  with unit vectors  $e_x, e_y, e_z$
3. origin = center of projection  $C$
4. image plane  $\pi$  at unit distance from  $C$
5. optical axis  $O$  is perpendicular to  $\pi$
6. principal point  $x_p$ : intersection of  $O$  and  $\pi$
7. perspective camera is given by  $C$  and  $\pi$

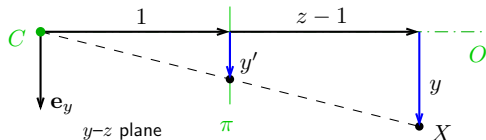

projected point in the natural image coordinate system:

$$\tan \alpha = \frac{y'}{1} = y' = \frac{y}{1 + z - 1} = \frac{y}{z}, \quad x' = \frac{x}{z}$$

## ► Natural and Canonical Image Coordinate Systems

projected point **in canonical camera** ( $z \neq 0$ )

$$(x', y', 1) = \left( \frac{x}{z}, \frac{y}{z}, 1 \right) = \frac{1}{z}(x, y, z) \simeq (x, y, z) \equiv \begin{bmatrix} x \\ y \\ z \end{bmatrix} = \underbrace{\begin{bmatrix} 1 & 0 & 0 & 0 \\ 0 & 1 & 0 & 0 \\ 0 & 0 & 1 & 0 \end{bmatrix}}_{\mathbf{P}_0 = [\mathbf{I} \quad \mathbf{0}]} \cdot \begin{bmatrix} x \\ y \\ z \\ 1 \end{bmatrix} = \mathbf{P}_0 \underline{\mathbf{X}}$$

projected point **in scanned image**

scale by  $f$  and translate origin to image corner

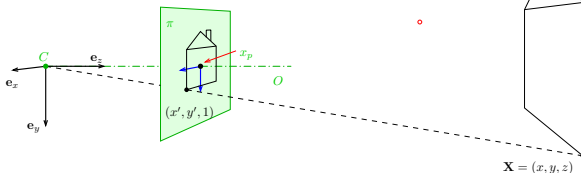
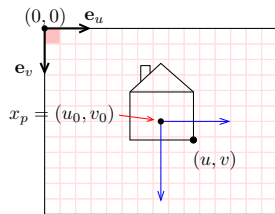

$$u = f \frac{x}{z} + u_0$$

$$v = f \frac{y}{z} + v_0$$

$$\frac{1}{z} \begin{bmatrix} f x + z u_0 \\ f y + z v_0 \\ z \end{bmatrix} \simeq \begin{bmatrix} f & 0 & u_0 \\ 0 & f & v_0 \\ 0 & 0 & 1 \end{bmatrix} \cdot \begin{bmatrix} 1 & 0 & 0 & 0 \\ 0 & 1 & 0 & 0 \\ 0 & 0 & 1 & 0 \end{bmatrix} \cdot \begin{bmatrix} x \\ y \\ z \\ 1 \end{bmatrix} = \mathbf{K} \mathbf{P}_0 \underline{\mathbf{X}} = \mathbf{P} \underline{\mathbf{X}}$$

- 'calibration' matrix  $\mathbf{K}$  transforms canonical  $\mathbf{P}_0$  to standard perspective camera  $\mathbf{P}$

## ► Computing with Perspective Camera Projection Matrix

Projection from world to image in standard camera  $\mathbf{P}$ :

$$\underbrace{\begin{bmatrix} f & 0 & u_0 & 0 \\ 0 & f & v_0 & 0 \\ 0 & 0 & 1 & 0 \end{bmatrix}}_{\mathbf{P}} \begin{bmatrix} x \\ y \\ z \\ 1 \end{bmatrix} = \begin{bmatrix} fx + u_0z \\ fy + v_0z \\ z \end{bmatrix} \simeq \underbrace{\begin{bmatrix} x + \frac{z}{f}u_0 \\ y + \frac{z}{f}v_0 \\ \frac{z}{f} \end{bmatrix}}_{(a)} \simeq \begin{bmatrix} m_1 \\ m_2 \\ m_3 \end{bmatrix} = \underline{\mathbf{m}}$$

cross-check:  $\frac{m_1}{m_3} = \frac{fx}{z} + u_0 = u$ ,  $\frac{m_2}{m_3} = \frac{fy}{z} + v_0 = v$  when  $m_3 \neq 0$

$f$  – ‘focal length’ – converts length ratios to pixels,  $[f] = \text{px}$ ,  $f > 0$

$(u_0, v_0)$  – principal point in pixels

### Perspective Camera:

1. dimension reduction

since  $\mathbf{P} \in \mathbb{R}^{3,4}$

2. nonlinear unit change  $\mathbf{1} \mapsto \mathbf{1} \cdot z/f$ , see (a)

for convenience we use  $P_{11} = P_{22} = f$  rather than  $P_{33} = 1/f$  and the  $u_0, v_0$  in relative units

3.  $m_3 = 0$  represents points at infinity in image plane  $\pi$

i.e. points with  $z = 0$

## ► Changing The Outer (World) Reference Frame

A transformation of a point from the world to camera coordinate system:

$$\mathbf{X}_c = \mathbf{R} \mathbf{X}_w + \mathbf{t}$$

$\mathbf{R}$  – camera rotation matrix

$\mathbf{t}$  – camera translation vector

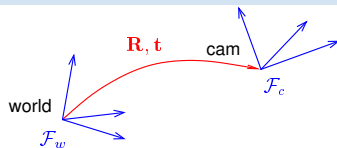

world orientation in the camera coordinate frame  $\mathcal{F}_c$   
world origin in the camera coordinate frame  $\mathcal{F}_c$

$$\mathbf{P} \underline{\mathbf{X}}_c = \mathbf{K} \mathbf{P}_0 \begin{bmatrix} \mathbf{X}_c \\ 1 \end{bmatrix} = \mathbf{K} \mathbf{P}_0 \begin{bmatrix} \mathbf{R} \mathbf{X}_w + \mathbf{t} \\ 1 \end{bmatrix} = \mathbf{K} \underbrace{\begin{bmatrix} \mathbf{I} & \mathbf{0} \end{bmatrix}}_{\mathbf{P}_0} \underbrace{\begin{bmatrix} \mathbf{R} & \mathbf{t} \\ \mathbf{0}^\top & 1 \end{bmatrix}}_{\mathbf{T}} \begin{bmatrix} \mathbf{X}_w \\ 1 \end{bmatrix} = \mathbf{K} \begin{bmatrix} \mathbf{R} & \mathbf{t} \end{bmatrix} \underline{\mathbf{X}}_w$$

$\mathbf{P}_0$  (a  $3 \times 4$  mtx) discards the last row of  $\mathbf{T}$

- $\mathbf{R}$  is rotation,  $\mathbf{R}^\top \mathbf{R} = \mathbf{I}$ ,  $\det \mathbf{R} = +1$
- **6 extrinsic parameters**: 3 rotation angles (Euler theorem), 3 translation components
- alternative, often used, camera representations

$\mathbf{I} \in \mathbb{R}^{3,3}$  identity matrix

$$\mathbf{P} = \mathbf{K} \begin{bmatrix} \mathbf{R} & \mathbf{t} \end{bmatrix} = \mathbf{K} \mathbf{R} \begin{bmatrix} \mathbf{I} & -\mathbf{C} \end{bmatrix}$$

$\mathbf{C}$  – camera position in the world reference frame  $\mathcal{F}_w$

$\mathbf{r}_3^\top$  – optical axis in the world reference frame  $\mathcal{F}_w$

$\mathbf{t} = -\mathbf{R}\mathbf{C}$

third row of  $\mathbf{R}$ :  $\mathbf{r}_3 = \mathbf{R}^{-1}[0, 0, 1]^\top$

- we can save some conversion and computation by noting that  $\mathbf{K} \mathbf{R} \begin{bmatrix} \mathbf{I} & -\mathbf{C} \end{bmatrix} \underline{\mathbf{X}} = \mathbf{K} \mathbf{R} (\underline{\mathbf{X}} - \mathbf{C})$



## ► Changing the Inner (Image) Reference Frame

The general form of calibration matrix  $\mathbf{K}$  includes

- skew angle  $\theta$  of the digitization raster
- pixel aspect ratio  $a$

$$\mathbf{K} = \begin{bmatrix} a f & -a f \cot \theta & u_0 \\ 0 & f / \sin \theta & v_0 \\ 0 & 0 & 1 \end{bmatrix} \quad \text{units: } [f] = \text{px}, [u_0] = \text{px}, [v_0] = \text{px}, [a] = 1$$

⊗ H1; 2pt: Give the parameters  $f, a, \theta, u_0, v_0$  a precise meaning by decomposing  $\mathbf{K}$  to simple maps; deadline LD+2 wk

Hints:

1. image projects to orthogonal system  $F^\perp$ , then it maps by skew to  $F'$ , then by scale  $a f, f$  to  $F''$ , then by translation by  $u_0, v_0$  to  $F'''$
2. Skew: Do not confuse it with the **shear mapping**. Express point  $\mathbf{x}$  as

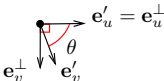
$$\mathbf{x} = u' \mathbf{e}_{u'} + v' \mathbf{e}_{v'} = u^\perp \mathbf{e}_u^\perp + v^\perp \mathbf{e}_v^\perp$$

$\mathbf{e}_i$  are unit-length basis vectors; consider their four pairwise dot-products.

3.  $\mathbf{K}$  maps from  $F^\perp$  to  $F'''$  as

$$w''' [u''', v''', 1]^\top = \mathbf{K} [u^\perp, v^\perp, 1]^\top$$

## ► Summary: Projection Matrix of a General Finite Perspective Camera

$$\underline{\mathbf{m}} \simeq \mathbf{P}\underline{\mathbf{X}}, \quad \mathbf{P} = [\mathbf{Q} \quad \mathbf{q}] \simeq \mathbf{K} [\mathbf{R} \quad \mathbf{t}] = \mathbf{K}\mathbf{R}[\mathbf{I} \quad -\mathbf{C}]$$

a recipe for filling  $\mathbf{P}$

**general finite perspective camera has 11 parameters:**

- 5 intrinsic parameters:  $f, u_0, v_0, a, \theta$
- 6 extrinsic parameters:  $\mathbf{t}, \mathbf{R}(\alpha, \beta, \gamma)$

finite camera:  $\det \mathbf{K} \neq 0$

**Representation Theorem:** The set of projection matrices  $\mathbf{P}$  of finite perspective cameras is isomorphic to the set of homogeneous  $3 \times 4$  matrices with the left  $3 \times 3$  submatrix  $\mathbf{Q}$  non-singular.

random finite camera: `Q = rand(3,3); while det(Q)==0, Q = rand(3,3); end, P = [Q, rand(3,1)];`

## ► Projection Matrix Decomposition

$$\mathbf{P} = [\mathbf{Q} \quad \mathbf{q}] \rightarrow \mathbf{K} [\mathbf{R} \quad \mathbf{t}]$$

$$\mathbf{Q} \in \mathbb{R}^{3,3}$$

$$\mathbf{K} \in \mathbb{R}^{3,3}$$

$$\mathbf{R} \in \mathbb{R}^{3,3}$$

full rank

(if finite perspective camera; see [H&Z, Sec. 6.3] for cameras at infinity)

upper triangular with positive diagonal elements

rotation mtx:  $\mathbf{R}^T \mathbf{R} = \mathbf{I}$  and  $\det \mathbf{R} = +1$

1.  $[\mathbf{Q} \quad \mathbf{q}] = \mathbf{K} [\mathbf{R} \quad \mathbf{t}] = [\mathbf{KR} \quad \mathbf{Kt}]$

also →35

2. RQ decomposition of  $\mathbf{Q} = \mathbf{KR}$  using three Givens rotations

[H&Z, p. 579]

$$\mathbf{K} = \mathbf{Q} \underbrace{\mathbf{R}_{32} \mathbf{R}_{31} \mathbf{R}_{21}}_{\mathbf{R}^{-1}} \quad \mathbf{Q} \mathbf{R}_{32} = \begin{bmatrix} \cdot & \cdot & \cdot \\ \cdot & \cdot & \cdot \\ \cdot & 0 & \cdot \end{bmatrix}, \quad \mathbf{Q} \mathbf{R}_{32} \mathbf{R}_{31} = \begin{bmatrix} \cdot & \cdot & \cdot \\ \cdot & \cdot & \cdot \\ 0 & 0 & \cdot \end{bmatrix}, \quad \mathbf{Q} \mathbf{R}_{32} \mathbf{R}_{31} \mathbf{R}_{21} = \begin{bmatrix} \cdot & \cdot & \cdot \\ 0 & \cdot & \cdot \\ 0 & 0 & \cdot \end{bmatrix}$$

$\mathbf{R}_{ij}$  zeroes element  $ij$  in  $\mathbf{Q}$  affecting only columns  $i$  and  $j$  and the sequence preserves previously zeroed elements, e.g.

(see the next slide for derivation details)

$$\mathbf{R}_{32} = \begin{bmatrix} 1 & 0 & 0 \\ 0 & c & -s \\ 0 & s & c \end{bmatrix} \text{ gives } 0 = k_{32} = c q_{32} + s q_{33} \Rightarrow c = \frac{q_{33}}{\sqrt{q_{32}^2 + q_{33}^2}} \quad s = \frac{-q_{32}}{\sqrt{q_{32}^2 + q_{33}^2}}$$

⊛ P1; 1pt: Multiply known matrices  $\mathbf{K}$ ,  $\mathbf{R}$  and then decompose back; discuss numerical errors

- RQ decomposition nonuniqueness:  $\mathbf{KR} = \mathbf{KT}^{-1}\mathbf{TR}$ , where  $\mathbf{T} = \text{diag}(-1, -1, 1)$  is also a rotation, we must correct the result so that the diagonal elements of  $\mathbf{K}$  are all positive 'thin' RQ decomposition
- care must be taken to avoid overflow, see [Golub & van Loan 2013, sec. 5.2]

## RQ Decomposition Step

```
Q = Array [qm1,m2 &, {3, 3}];  
R32 = {{1, 0, 0}, {0, c, -s}, {0, s, c}}; R32 // MatrixForm
```

$$\begin{pmatrix} 1 & 0 & 0 \\ 0 & c & -s \\ 0 & s & c \end{pmatrix}$$

```
Q1 = Q . R32 ; Q1 // MatrixForm
```

$$\begin{pmatrix} q_{1,1} & c q_{1,2} + s q_{1,3} & -s q_{1,2} + c q_{1,3} \\ q_{2,1} & c q_{2,2} + s q_{2,3} & -s q_{2,2} + c q_{2,3} \\ q_{3,1} & c q_{3,2} + s q_{3,3} & -s q_{3,2} + c q_{3,3} \end{pmatrix}$$

```
s1 = Solve [{Q1[[3]][[2]] == 0, c^2 + s^2 == 1}, {c, s}][[2]]
```

$$\left\{ c \rightarrow \frac{q_{3,3}}{\sqrt{q_{3,2}^2 + q_{3,3}^2}}, s \rightarrow -\frac{q_{3,2}}{\sqrt{q_{3,2}^2 + q_{3,3}^2}} \right\}$$

```
Q1 /. s1 // Simplify // MatrixForm
```

$$\begin{pmatrix} q_{1,1} & \frac{-q_{1,3} q_{3,2} + q_{1,2} q_{3,3}}{\sqrt{q_{3,2}^2 + q_{3,3}^2}} & \frac{q_{1,2} q_{3,2} + q_{1,3} q_{3,3}}{\sqrt{q_{3,2}^2 + q_{3,3}^2}} \\ q_{2,1} & \frac{-q_{2,3} q_{3,2} + q_{2,2} q_{3,3}}{\sqrt{q_{3,2}^2 + q_{3,3}^2}} & \frac{q_{2,2} q_{3,2} + q_{2,3} q_{3,3}}{\sqrt{q_{3,2}^2 + q_{3,3}^2}} \\ q_{3,1} & 0 & \sqrt{q_{3,2}^2 + q_{3,3}^2} \end{pmatrix}$$

## ► Center of Projection (Optical Center)

**Observation:** finite  $\mathbf{P}$  has a non-trivial right null-space

rank 3 but 4 columns

### Theorem

Let  $\mathbf{P}$  be a camera and let there be  $\underline{\mathbf{B}} \neq \mathbf{0}$  s.t.  $\mathbf{P} \underline{\mathbf{B}} = \mathbf{0}$ . Then  $\underline{\mathbf{B}}$  is equivalent to the projection center  $\underline{\mathbf{C}}$  (homogeneous, in world coordinate frame).

### Proof.

1. Let  $AB$  be a spatial line ( $B$  given from  $\mathbf{P} \underline{\mathbf{B}} = \mathbf{0}$ ,  $A \neq B$ ). Then

$$\underline{\mathbf{X}}(\lambda) \simeq \lambda \underline{\mathbf{A}} + (1 - \lambda) \underline{\mathbf{B}}, \quad \lambda \in \mathbb{R} \quad (\text{world frame})$$

2. It projects to

$$\mathbf{P} \underline{\mathbf{X}}(\lambda) \simeq \lambda \mathbf{P} \underline{\mathbf{A}} + (1 - \lambda) \mathbf{P} \underline{\mathbf{B}} \simeq \mathbf{P} \underline{\mathbf{A}}$$

- the entire line projects to a single point  $\Rightarrow$  it must pass through the projection center of  $\mathbf{P}$
- this holds for any choice of  $A \neq B \Rightarrow$  the only common point of the lines is the  $C$ , i.e.  $\underline{\mathbf{B}} \simeq \underline{\mathbf{C}}$

□

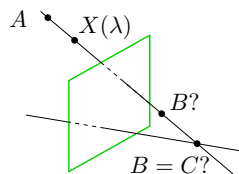

Hence

$$\mathbf{0} = \mathbf{P} \underline{\mathbf{C}} = [\mathbf{Q} \quad \mathbf{q}] \begin{bmatrix} \underline{\mathbf{C}} \\ 1 \end{bmatrix} = \mathbf{Q} \underline{\mathbf{C}} + \mathbf{q} \Rightarrow \underline{\mathbf{C}} = -\mathbf{Q}^{-1} \mathbf{q}$$

$\underline{\mathbf{C}} = (c_j)$ , where  $c_j = (-1)^j \det \mathbf{P}^{(j)}$ , in which  $\mathbf{P}^{(j)}$  is  $\mathbf{P}$  with column  $j$  dropped

Matlab: `C_homo = null(P);` or `C = -Q\q;`

## ► Optical Ray

Optical ray: Spatial line that projects to a single image point.

1. Consider the following spatial line (world frame)

$\mathbf{d} \in \mathbb{R}^3$  line direction vector,  $\|\mathbf{d}\| = 1$ ,  $\lambda \in \mathbb{R}$ , Cartesian representation

$$\mathbf{X}(\lambda) = \mathbf{C} + \lambda \mathbf{d}$$

2. The projection of the (finite) point  $X(\lambda)$  is

$$\begin{aligned} \underline{\mathbf{m}} &\simeq [\mathbf{Q} \quad \mathbf{q}] \begin{bmatrix} \mathbf{X}(\lambda) \\ 1 \end{bmatrix} = \mathbf{Q}(\mathbf{C} + \lambda \mathbf{d}) + \mathbf{q} = \lambda \mathbf{Q} \mathbf{d} = \\ &= \lambda [\mathbf{Q} \quad \mathbf{q}] \begin{bmatrix} \mathbf{d} \\ 0 \end{bmatrix} \end{aligned}$$

... which is also the image of a point at infinity in  $\mathbb{P}^3$

- optical ray line corresponding to image point  $m$  is the set

$$\mathbf{X}(\mu) = \mathbf{C} + \mu \mathbf{Q}^{-1} \underline{\mathbf{m}}, \quad \mu \in \mathbb{R} \quad (\mu = 1/\lambda)$$

- optical ray direction may be represented by a point at infinity  $(\mathbf{d}, 0)$  in  $\mathbb{P}^3$
- optical ray is expressed in world coordinate frame

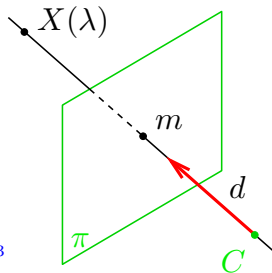

## ► Optical Axis

Optical axis: Optical ray that is perpendicular to image plane  $\pi$

1. points  $X$  on a given line  $N$  parallel to  $\pi$  project to a point at infinity  $(u, v, 0)$  in  $\pi$ :

$$\begin{bmatrix} u \\ v \\ 0 \end{bmatrix} \simeq \mathbf{P}\mathbf{X} = \begin{bmatrix} \mathbf{q}_1^\top & q_{14} \\ \mathbf{q}_2^\top & q_{24} \\ \mathbf{q}_3^\top & q_{34} \end{bmatrix} \begin{bmatrix} \mathbf{X} \\ 1 \end{bmatrix}$$

2. therefore the set of points  $X$  is parallel to  $\pi$  iff

$$\mathbf{q}_3^\top \mathbf{X} + q_{34} = 0$$

3. this is a plane equation with  $\pm \mathbf{q}_3$  as the normal vector
4. optical axis direction: substitution  $\mathbf{P} \mapsto \lambda \mathbf{P}$  must not change the direction
5. we select (assuming  $\det(\mathbf{R}) > 0$ )

$$\mathbf{o} = \det(\mathbf{Q}) \mathbf{q}_3$$

if  $\mathbf{P} \mapsto \lambda \mathbf{P}$  then  $\det(\mathbf{Q}) \mapsto \lambda^3 \det(\mathbf{Q})$  and  $\mathbf{q}_3 \mapsto \lambda \mathbf{q}_3$

[H&Z, p. 161]

- the axis is expressed in world coordinate frame

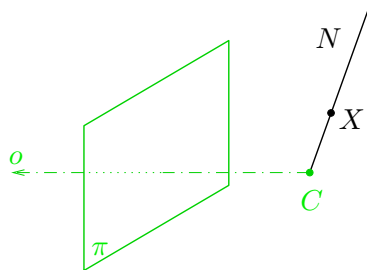

## ► Principal Point

Principal point: The intersection of image plane and the optical axis

1. as we saw,  $\mathbf{q}_3$  is the directional vector of optical axis
2. we take point at infinity on the optical axis that must project to the principal point  $m_0$

3. then

$$\underline{\mathbf{m}}_0 \simeq [\mathbf{Q} \quad \mathbf{q}] \begin{bmatrix} \mathbf{q}_3 \\ 0 \end{bmatrix} = \mathbf{Q} \mathbf{q}_3$$

principal point:  $\underline{\mathbf{m}}_0 \simeq \mathbf{Q} \mathbf{q}_3$

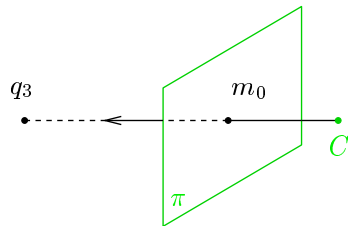

- principal point is also the center of radial distortion



## ► Optical Plane

A spatial plane with normal  $p$  containing the projection center  $C$  and a given image line  $n$ .

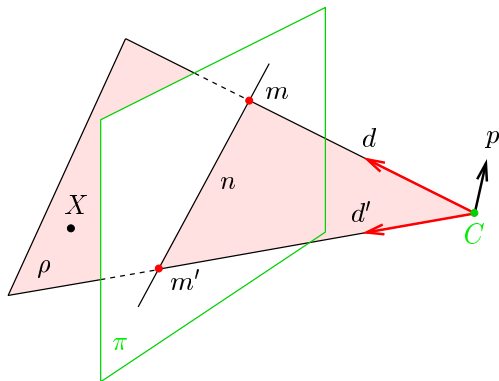

$$\begin{aligned} \text{optical ray given by } m & \quad \underline{d} \simeq \mathbf{Q}^{-1} \underline{m} \\ \text{optical ray given by } m' & \quad \underline{d}' \simeq \mathbf{Q}^{-1} \underline{m}' \end{aligned}$$

$$\underline{p} \simeq \underline{d} \times \underline{d}' = (\mathbf{Q}^{-1} \underline{m}) \times (\mathbf{Q}^{-1} \underline{m}') = \mathbf{Q}^T (\underline{m} \times \underline{m}') = \mathbf{Q}^T \underline{n}$$

• note the way  $\mathbf{Q}$  factors out!

$$\text{hence, } 0 = \underline{p}^T (\underline{X} - \underline{C}) = \underline{n}^T \underbrace{\mathbf{Q}(\underline{X} - \underline{C})}_{\rightarrow 30} = \underline{n}^T \mathbf{P} \underline{X} = (\mathbf{P}^T \underline{n})^T \underline{X} \quad \text{for every } X \text{ in plane } \rho$$

$$\text{optical plane is given by } n: \quad \underline{\rho} \simeq \mathbf{P}^T \underline{n}$$

$$\rho_1 x + \rho_2 y + \rho_3 z + \rho_4 = 0$$

## Cross-Check: Optical Ray as Optical Plane Intersection

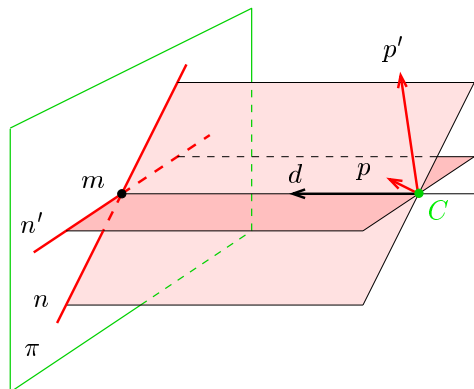

optical plane normal given by  $\underline{n}$

optical plane normal given by  $\underline{n}'$

$$\underline{d} = \underline{p} \times \underline{p}' = (\mathbf{Q}^T \underline{n}) \times (\mathbf{Q}^T \underline{n}') = \mathbf{Q}^{-1}(\underline{n} \times \underline{n}') = \mathbf{Q}^{-1} \underline{m}$$

$$\underline{p} = \mathbf{Q}^T \underline{n}$$

$$\underline{p}' = \mathbf{Q}^T \underline{n}'$$

## ► Summary: Projection Center; Optical Ray, Axis, Plane

General (finite) camera

$$\mathbf{P} = [\mathbf{Q} \quad \mathbf{q}] = \begin{bmatrix} \mathbf{q}_1^\top & q_{14} \\ \mathbf{q}_2^\top & q_{24} \\ \mathbf{q}_3^\top & q_{34} \end{bmatrix} = \mathbf{K} [\mathbf{R} \quad \mathbf{t}] = \mathbf{K} \mathbf{R} [\mathbf{I} \quad -\mathbf{C}]$$

$\underline{\mathbf{C}} \simeq \text{rnull}(\mathbf{P})$ ,  $\mathbf{C} = -\mathbf{Q}^{-1} \mathbf{q}$  projection center (world coords.) →35

$\mathbf{d} = \mathbf{Q}^{-1} \underline{\mathbf{m}}$  optical ray direction (world coords.) →36

$\mathbf{o} = \det(\mathbf{Q}) \mathbf{q}_3$  outward optical axis (world coords.) →37

$\underline{\mathbf{m}}_0 \simeq \mathbf{Q} \mathbf{q}_3$  principal point (in image plane) →38

$\underline{\rho} = \mathbf{P}^\top \underline{\mathbf{n}}$  optical plane (world coords.) →39

$\mathbf{K} = \begin{bmatrix} a f & -a f \cot \theta & u_0 \\ 0 & f / \sin \theta & v_0 \\ 0 & 0 & 1 \end{bmatrix}$  camera (calibration) matrix ( $f, u_0, v_0$  in pixels) →31

$\mathbf{R}$  camera rotation matrix (cam coords.) →30

$\mathbf{t}$  camera translation vector (cam coords.) →30

# What Can We Do with An 'Uncalibrated' Perspective Camera?



How far is the engine from a given point on the tracks?

distance between sleepers (ties) 0.806m but we cannot count them, the image resolution is too low

We will review some life-saving theory...  
... and build a bit of geometric intuition...

## In fact

- 'uncalibrated' = the image contains a 'calibrating object' that suffices for the task at hand

## ► Vanishing Point

**Vanishing point (V.P.):** The limit  $m_\infty$  of the projection of a point  $\mathbf{X}(\lambda)$  that moves along a space line  $\mathbf{X}(\lambda) = \mathbf{X}_0 + \lambda \mathbf{d}$  infinitely in one direction. the image of the point at infinity on the line

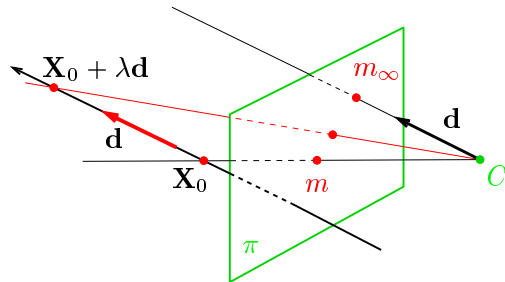

$$\underline{m}_\infty \simeq \lim_{\lambda \rightarrow \pm\infty} \mathbf{P} \begin{bmatrix} \mathbf{X}_0 + \lambda \mathbf{d} \\ 1 \end{bmatrix} = \dots \simeq \mathbf{Q} \mathbf{d} \quad \text{⊗ P1; 1pt: Prove (use Cartesian coordinates and L'Hôpital's rule)}$$

- the V.P. of a spatial line with directional vector  $\mathbf{d}$  is  $\underline{m}_\infty \simeq \mathbf{Q} \mathbf{d}$
- V.P. is independent on line position  $\mathbf{X}_0$ , it depends on its directional vector only
- all parallel (world) lines share the same (image) V.P., including the optical ray defined by  $m_\infty$

# Some Vanishing Point “Applications”



where is the sun?



what is the wind direction?  
(must have video)



fly above the lane,  
at constant altitude!

## ► Vanishing Line

**Vanishing line (V.L.):** The set of vanishing points of all lines in a plane the image of the line at infinity in the plane and in all parallel planes (!)

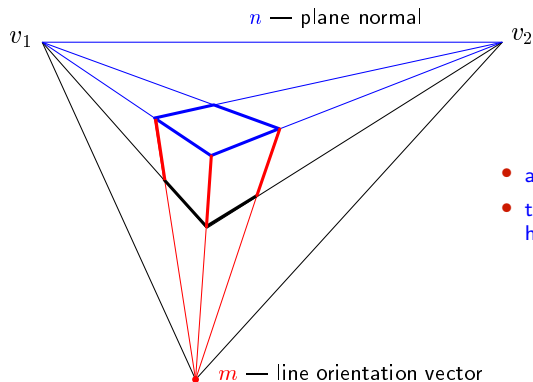

- any box with parallel edges
- top (blue) and bottom (black) box planes are parallel, hence they share V.L.  $n$

- V.L.  $n$  corresponds to spatial plane of normal vector  $\mathbf{p} = \mathbf{Q}^T \underline{\mathbf{n}}$   
because this is the normal vector of a parallel optical plane (!) →39
- a spatial plane of normal vector  $\mathbf{p}$  has a V.L. represented by  $\underline{\mathbf{n}} = \mathbf{Q}^{-T} \mathbf{p}$ .

## ► Cross Ratio

Four distinct collinear spatial points  $R, S, T, U$  define cross-ratio

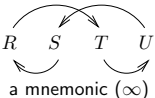
$$[RSTU] = \frac{|\overrightarrow{RT}|}{|\overrightarrow{SR}|} \frac{|\overrightarrow{US}|}{|\overrightarrow{TU}|}$$

a mnemonic ( $\infty$ )

- $|\overrightarrow{RT}|$  – signed distance from  $R$  to  $T$  in the arrow direction
- each point  $X$  is once in numerator and once in denominator
- if  $X$  is 1st in a numerator term, it is 2nd in a denominator term
- there are six cross-ratios from four points:

$$[SRUT] = [RSTU], [RSUT] = \frac{1}{[RSTU]}, [RTSU] = 1 - [RSTU], \dots$$

**Obs:**  $[RSTU] = \frac{|\underline{\mathbf{r}} \ \underline{\mathbf{t}} \ \underline{\mathbf{v}}|}{|\underline{\mathbf{s}} \ \underline{\mathbf{r}} \ \underline{\mathbf{v}}|} \cdot \frac{|\underline{\mathbf{u}} \ \underline{\mathbf{s}} \ \underline{\mathbf{v}}|}{|\underline{\mathbf{t}} \ \underline{\mathbf{u}} \ \underline{\mathbf{v}}|}, \quad |\underline{\mathbf{r}} \ \underline{\mathbf{t}} \ \underline{\mathbf{v}}| = \det [\underline{\mathbf{r}} \ \underline{\mathbf{t}} \ \underline{\mathbf{v}}] = (\underline{\mathbf{r}} \times \underline{\mathbf{t}})^\top \underline{\mathbf{v}} \quad \text{mixed product} \quad (1)$

### Corollaries:

- cross ratio is invariant under homographies  $\underline{\mathbf{x}}' \simeq \mathbf{H}\underline{\mathbf{x}}$
- cross ratio is invariant under perspective projection:  $[RSTU] = [rstu]$
- 4 collinear points: any perspective camera will “see” the same cross-ratio of their images
- we measure the same cross-ratio in image as on the world line
- one of the points  $R, S, T, U$  may be at infinity (we take the limit, in effect  $\frac{\infty}{\infty} = 1$ )

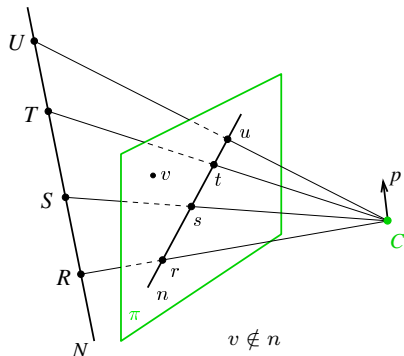

proof: plug  $\mathbf{H}\underline{\mathbf{x}}$  in (1):  $(\mathbf{H}^{-\top}(\underline{\mathbf{r}} \times \underline{\mathbf{t}}))^\top \mathbf{H}\underline{\mathbf{v}}$



## ► 1D Projective Coordinates

The 1-D projective coordinate of a point  $P$  is defined by the following cross-ratio:

$$[P] = [P_0 P_1 P P_\infty] = [p_0 p_1 p p_\infty] = \frac{|\overrightarrow{p_0 p}|}{|\overrightarrow{p_1 p_0}|} \frac{|\overrightarrow{p_\infty p_1}|}{|\overrightarrow{p p_\infty}|} = [p]$$

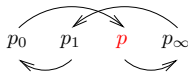

naming convention:

$P_0$  – the origin

$$[P_0] = 0$$

$P_1$  – the unit point

$$[P_1] = 1$$

$P_\infty$  – the supporting point

$$[P_\infty] = \pm\infty$$

$$[P] = [p]$$

$[P]$  is equal to Euclidean coordinate along  $N$

$[p]$  is its measurement in the image plane

if the sign is not of interest, any cross-ratio containing  $|p_0 p|$  does the job

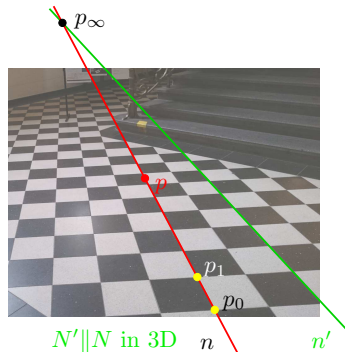

### Applications

- Given the image of a 3D line  $N$ , the origin, the unit point, and the vanishing point, then the Euclidean coordinate of any point  $P \in N$  can be determined →48
- Finding V.P. of a line through a regular object →49

# Application: Counting Steps

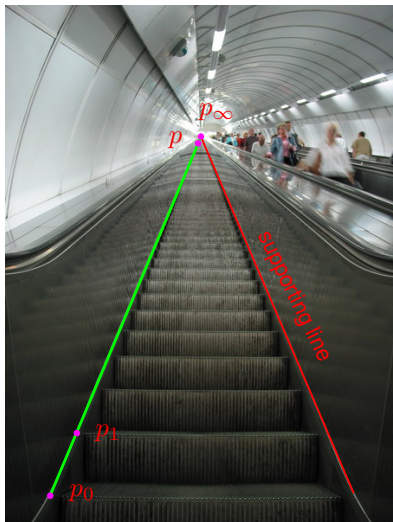

- Namesti Miru underground station in Prague

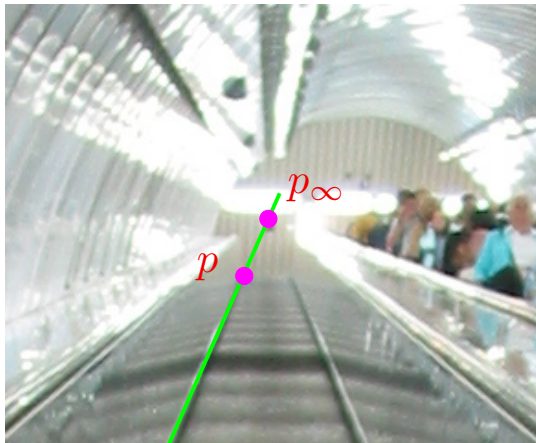

detail around the vanishing point

**Result:**  $[P] = 214$  steps (correct answer is 216 steps)

4Mpx camera

# Application: Finding the Horizon from Repetitions

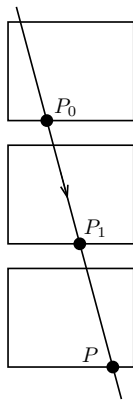
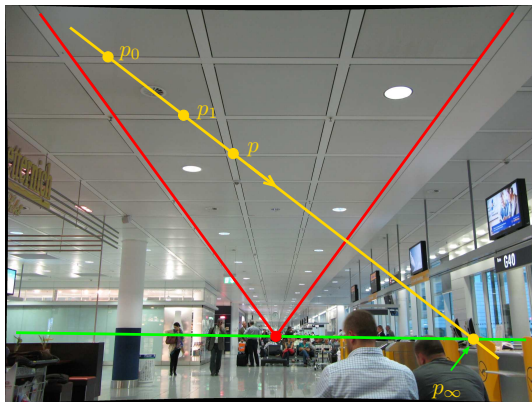

in 3D:  $|P_0P| = 2|P_0P_1|$  then

[H&Z, p. 218]

$$[P_0P_1PP_\infty] = \frac{|P_0P|}{|P_1P_0|} = 2 \quad \Rightarrow \quad x_\infty = \frac{x_0(2x - x_1) - xx_1}{x + x_0 - 2x_1}$$

- $x$  - 1D coordinate along the yellow line, positive in the arrow direction
- could be applied to counting steps ( $\rightarrow 48$ ) if there was no supporting line

⊛ P1; 1pt: How high is the camera above the floor?

# Homework Problem

⊗ H2; 3pt: What is the ratio of heights of Building A to Building B?

- expected: conceptual solution; use notation from this figure
- deadline: LD+2 weeks

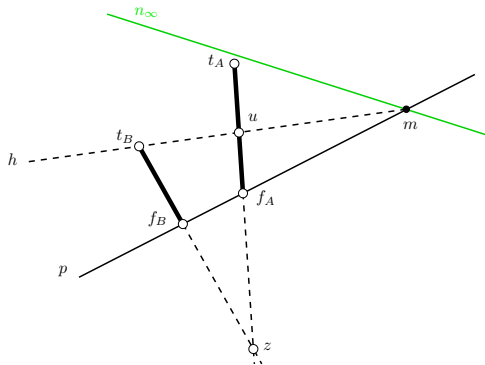
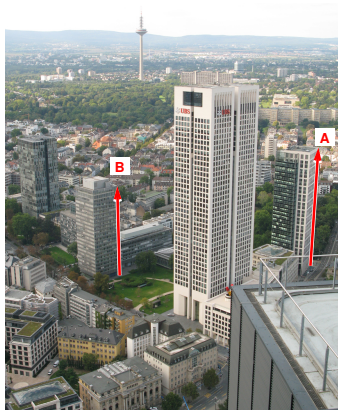

## Hints

1. What are the interesting properties of line  $h$  connecting the top  $t_B$  of Building B with the point  $m$  at which the horizon intersects the line  $p$  joining the feet  $f_A, f_B$  of both buildings? [1 point]
2. How do we actually get the horizon  $n_\infty$ ? (we do not see it directly, there are some hills there...) [1 point]
3. Give a formula for measuring the length ratio. Make sure you distinguish points in 3D from their images. [formula = 1 point]

# 2D Projective Coordinates

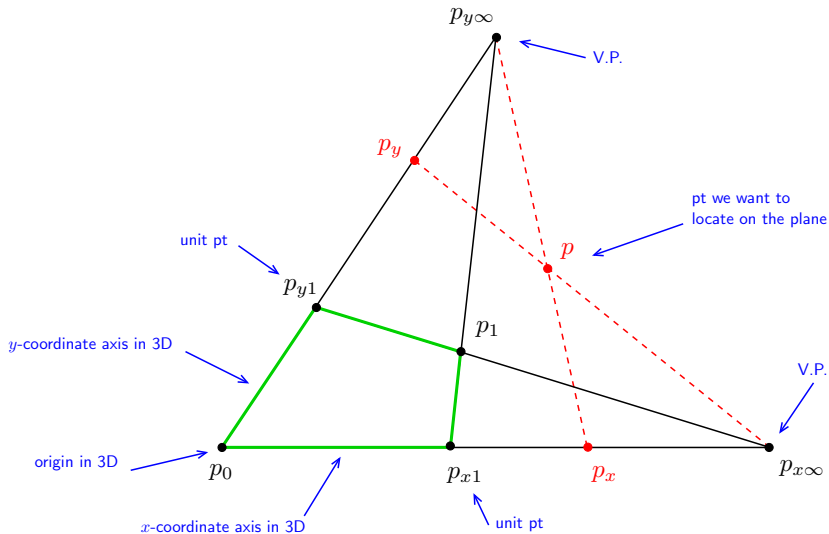

$$[P_x] = [P_0 \ P_{x1} \ P_x \ P_{x\infty}]$$

$$[P_y] = [P_0 \ P_{y1} \ P_y \ P_{y\infty}]$$

## Application: Measuring on the Floor (Wall, etc)



San Giovanni in Laterano, Rome

- measuring distances on the floor in terms of tile units
- what are the dimensions of the seal? Is it circular (assuming square tiles)?
- needs no explicit camera calibration

because we can see the calibrating object (vanishing points)

## Computing with a Single Camera

- 3.1 Calibration: Internal Camera Parameters from Vanishing Points and Lines
- 3.2 Camera Resection: Projection Matrix from 6 Known Points
- 3.3 Exterior Orientation: Camera Rotation and Translation from 3 Known Points
- 3.4 Relative Orientation Problem: Rotation and Translation between Two Point Sets

### covered by

- [1] [H&Z] Secs: 8.6, 7.1, 22.1
- [2] Fischler, M.A. and Bolles, R.C. . Random Sample Consensus: A Paradigm for Model Fitting with Applications to Image Analysis and Automated Cartography. *Communications of the ACM* 24(6):381–395, 1981
- [3] [Golub & van Loan 2013, Sec. 2.5]

# Obtaining Vanishing Points and Lines

- orthogonal direction pairs can be collected from multiple images by camera rotation

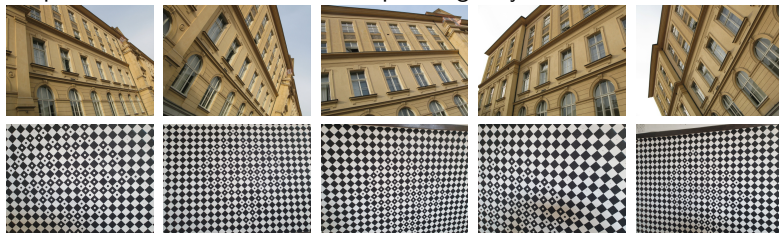

- vanishing line can be obtained from vanishing points and/or regularities (→49)

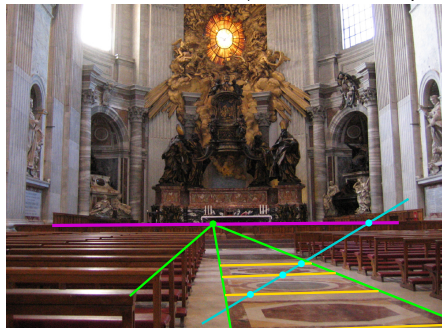



## ► Camera Calibration from Vanishing Points and Lines

**Problem:** Given finite vanishing points and/or vanishing lines, compute  $\mathbf{K}$

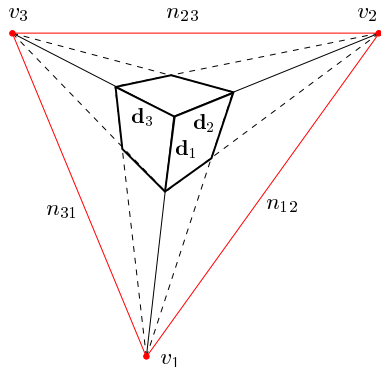

$$\begin{aligned} \mathbf{d}_i &= \lambda_i \mathbf{Q}^{-1} \mathbf{v}_i, & i = 1, 2, 3 & \rightarrow 43 \\ \mathbf{p}_{ij} &= \mu_{ij} \mathbf{Q}^T \mathbf{n}_{ij}, & i, j = 1, 2, 3, i \neq j & \rightarrow 39 \end{aligned} \quad (2)$$

- method: eliminate  $\lambda_i, \mu_{ij}, \mathbf{R}$  from (2) and solve for  $\mathbf{K}$ .

**Configurations allowing elimination of  $\mathbf{R}$**

1. orthogonal rays  $\mathbf{d}_1 \perp \mathbf{d}_2$  in space then

$$0 = \mathbf{d}_1^T \mathbf{d}_2 = \mathbf{v}_1^T \mathbf{Q}^{-T} \mathbf{Q}^{-1} \mathbf{v}_2 = \mathbf{v}_1^T \underbrace{(\mathbf{K}\mathbf{K}^T)^{-1}}_{\omega \text{ (IAC)}} \mathbf{v}_2$$

2. orthogonal planes  $\mathbf{p}_{ij} \perp \mathbf{p}_{ik}$  in space

$$0 = \mathbf{p}_{ij}^T \mathbf{p}_{ik} = \mathbf{n}_{ij}^T \mathbf{Q} \mathbf{Q}^T \mathbf{n}_{ik} = \mathbf{n}_{ij}^T \omega^{-1} \mathbf{n}_{ik}$$

3. orthogonal ray and plane  $\mathbf{d}_k \parallel \mathbf{p}_{ij}, k \neq i, j$

normal parallel to optical ray

$$\mathbf{p}_{ij} \simeq \mathbf{d}_k \Rightarrow \mathbf{Q}^T \mathbf{n}_{ij} = \frac{\lambda_i}{\mu_{ij}} \mathbf{Q}^{-1} \mathbf{v}_k \Rightarrow \mathbf{n}_{ij} = \varkappa \mathbf{Q}^{-T} \mathbf{Q}^{-1} \mathbf{v}_k = \varkappa \omega \mathbf{v}_k, \quad \varkappa \neq 0$$

- $n_{ij}$  may be constructed from non-orthogonal  $v_i$  and  $v_j$ , e.g. using the cross-ratio
- $\omega$  is a symmetric, positive definite  $3 \times 3$  matrix
- equations are quadratic in  $\mathbf{K}$  but linear in  $\omega$

IAC = Image of Absolute Conic

configuration	equation	# constraints
(3) orthogonal vanishing points	$\underline{\mathbf{v}}_i^\top \boldsymbol{\omega} \underline{\mathbf{v}}_j = 0$	1
(4) orthogonal vanishing lines	$\underline{\mathbf{n}}_{ij}^\top \boldsymbol{\omega}^{-1} \underline{\mathbf{n}}_{ik} = 0$	1
(5) vanishing points orthogonal to vanishing lines	$\underline{\mathbf{n}}_{ij} = \varkappa \boldsymbol{\omega} \underline{\mathbf{v}}_k$	2
(6) orthogonal image raster $\theta = \pi/2$	$\omega_{12} = \omega_{21} = 0$	1
(7) unit aspect $a = 1$ when $\theta = \pi/2$	$\omega_{11} - \omega_{22} = 0$	1
(8) known principal point $u_0 = v_0 = 0$	$\omega_{13} = \omega_{31} = \omega_{23} = \omega_{32} = 0$	2

- these are homogeneous linear equations for the 5 parameters in  $\boldsymbol{\omega}$  or  $\boldsymbol{\omega}^{-1}$  in the form  $\mathbf{D}\mathbf{w} = \mathbf{0}$   
 $\varkappa$  can be eliminated from (5)
- we need at least 5 constraints for full  $\boldsymbol{\omega}$  symmetric  $3 \times 3$
- we get  $\mathbf{K}$  from  $\boldsymbol{\omega}^{-1} = \mathbf{K}\mathbf{K}^\top$  by Choleski decomposition  
the decomposition returns a positive definite upper triangular matrix  
one avoids solving an explicit set of quadratic equations for the parameters in  $\mathbf{K}$

## Examples

Assuming orthogonal raster, unit aspect (ORUA):  $\theta = \pi/2$ ,  $a = 1$

$$\boldsymbol{\omega} \simeq \begin{bmatrix} 1 & 0 & -u_0 \\ 0 & 1 & -v_0 \\ -u_0 & -v_0 & f^2 + u_0^2 + v_0^2 \end{bmatrix}$$

### Ex 1:

Assuming ORUA and known  $\mathbf{m}_0 = (u_0, v_0)$ , two finite orthogonal vanishing points give  $f$

$$\underline{\mathbf{v}}_1^\top \boldsymbol{\omega} \underline{\mathbf{v}}_2 = 0 \quad \Rightarrow \quad f^2 = |(\mathbf{v}_1 - \mathbf{m}_0)^\top (\mathbf{v}_2 - \mathbf{m}_0)|$$

in this formula,  $\mathbf{v}_{1,2}$ ,  $\mathbf{m}_0$  are Cartesian (not homogeneous)!

### Ex 2:

Non-orthogonal vanishing points  $\mathbf{v}_i$ ,  $\mathbf{v}_j$ , known angle  $\phi$ :  $\cos \phi = \frac{\underline{\mathbf{v}}_i^\top \boldsymbol{\omega} \underline{\mathbf{v}}_j}{\sqrt{\underline{\mathbf{v}}_i^\top \boldsymbol{\omega} \underline{\mathbf{v}}_i} \sqrt{\underline{\mathbf{v}}_j^\top \boldsymbol{\omega} \underline{\mathbf{v}}_j}}$

- leads to polynomial equations
- e.g. ORUA and  $u_0 = v_0 = 0$  gives

$$(f^2 + \mathbf{v}_i^\top \mathbf{v}_j)^2 = (f^2 + \|\mathbf{v}_i\|^2) \cdot (f^2 + \|\mathbf{v}_j\|^2) \cdot \cos^2 \phi$$

## ► Camera Orientation from Two Finite Vanishing Points

**Problem:** Given  $\mathbf{K}$  and two vanishing points corresponding to two known orthogonal directions  $\mathbf{d}_1, \mathbf{d}_2$ , compute camera orientation  $\mathbf{R}$  with respect to the plane.

- 3D coordinate system choice, e.g.:

$$\mathbf{d}_1 = (1, 0, 0), \quad \mathbf{d}_2 = (0, 1, 0)$$

- we know that

$$\mathbf{d}_i \simeq \mathbf{Q}^{-1} \mathbf{v}_i = (\mathbf{KR})^{-1} \mathbf{v}_i = \mathbf{R}^{-1} \underbrace{\mathbf{K}^{-1} \mathbf{v}_i}_{\mathbf{w}_i}$$

$$\mathbf{R} \mathbf{d}_i \simeq \mathbf{w}_i$$

- knowing  $\mathbf{d}_{1,2}$  we conclude that  $\mathbf{w}_i / \|\mathbf{w}_i\|$  is the  $i$ -th column  $\mathbf{r}_i$  of  $\mathbf{R}$
- the third column is orthogonal:  $\mathbf{r}_3 \simeq \mathbf{r}_1 \times \mathbf{r}_2$

$$\mathbf{R} = \begin{bmatrix} \frac{\mathbf{w}_1}{\|\mathbf{w}_1\|} & \frac{\mathbf{w}_2}{\|\mathbf{w}_2\|} & \frac{\mathbf{w}_1 \times \mathbf{w}_2}{\|\mathbf{w}_1 \times \mathbf{w}_2\|} \end{bmatrix}$$

- we have to care about the signs  $\pm \mathbf{w}_i$  (such that  $\det \mathbf{R} = 1$ )

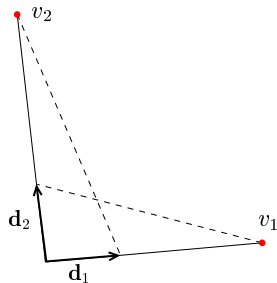

some suitable scenes



# Application: Planar Rectification

**Principle:** Rotate camera (image plane) parallel to the plane of interest.



$$\underline{\mathbf{m}} \simeq \mathbf{KR} [\mathbf{I} \quad -\mathbf{C}] \underline{\mathbf{X}}$$

$$\underline{\mathbf{m}}' \simeq \mathbf{K} [\mathbf{I} \quad -\mathbf{C}] \underline{\mathbf{X}}$$

$$\underline{\mathbf{m}}' \simeq \mathbf{K}(\mathbf{KR})^{-1} \underline{\mathbf{m}} = \mathbf{KR}^{\top} \mathbf{K}^{-1} \underline{\mathbf{m}} = \mathbf{H} \underline{\mathbf{m}}$$

- $\mathbf{H}$  is the rectifying homography
- both  $\mathbf{K}$  and  $\mathbf{R}$  can be calibrated from two finite vanishing points
- not possible when one of them is (or both are) infinite
- without ORUA we would need 4 additional views to calibrate  $\mathbf{K}$  as on  $\rightarrow 54$

assuming ORUA  $\rightarrow 57$

## ► Camera Resection

Camera calibration and orientation from a known set of  $k \geq 6$  reference points and their images  $\{(X_i, m_i)\}_{i=1}^6$ .

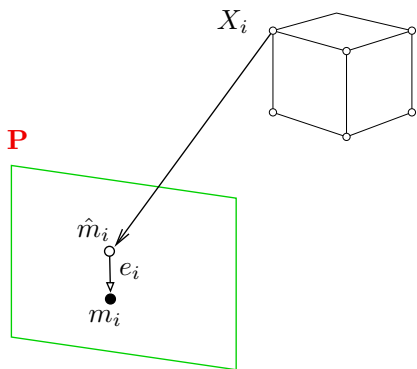

- $X_i$  are considered exact
- $m_i$  is a measurement subject to detection error

$$\mathbf{m}_i = \hat{\mathbf{m}}_i + \mathbf{e}_i \quad \text{Cartesian}$$

- where  $\lambda_i \hat{\mathbf{m}}_i = \mathbf{P} \mathbf{X}_i$

# Resection Targets

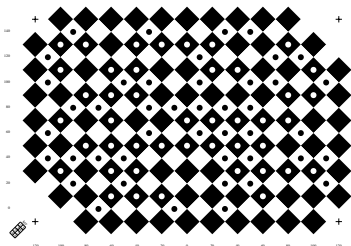

calibration chart

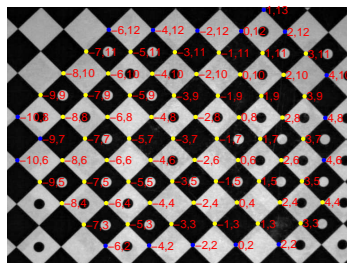

automatic calibration point detection  
based on a distributed bitcode ( $2 \times 4 = 8$  bits)

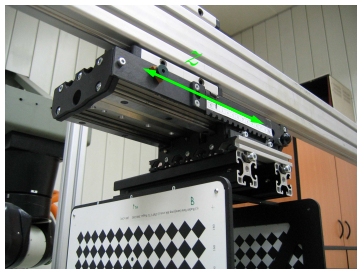

resection target with translation stage

- target translated at least once
- by a calibrated (known) translation
- $X_i$  point locations looked up in a table based on their bitcode

## ► The Minimal Problem for Camera Resection

**Problem:** Given  $k = 6$  corresponding pairs  $\{(X_i, m_i)\}_{i=1}^k$ , find  $\mathbf{P}$

$$\lambda_i \underline{\mathbf{m}}_i = \mathbf{P} \underline{\mathbf{X}}_i, \quad \mathbf{P} = \begin{bmatrix} \mathbf{q}_1^\top & q_{14} \\ \mathbf{q}_2^\top & q_{24} \\ \mathbf{q}_3^\top & q_{34} \end{bmatrix} \quad \begin{aligned} \underline{\mathbf{X}}_i &= (x_i, y_i, z_i, 1), \quad i = 1, 2, \dots, k, \quad k = 6 \\ \underline{\mathbf{m}}_i &= (u_i, v_i, 1), \quad \lambda_i \in \mathbb{R}, \lambda_i \neq 0, |\lambda_i| < \infty \end{aligned}$$

easily modifiable for infinite points  $X_i$  but be aware of  $\rightarrow 64$

expanded:  $\lambda_i u_i = \mathbf{q}_1^\top \mathbf{X}_i + q_{14}, \quad \lambda_i v_i = \mathbf{q}_2^\top \mathbf{X}_i + q_{24}, \quad \lambda_i = \mathbf{q}_3^\top \mathbf{X}_i + q_{34}$

after elimination of  $\lambda_i$ :  $(\mathbf{q}_3^\top \mathbf{X}_i + q_{34})u_i = \mathbf{q}_1^\top \mathbf{X}_i + q_{14}, \quad (\mathbf{q}_3^\top \mathbf{X}_i + q_{34})v_i = \mathbf{q}_2^\top \mathbf{X}_i + q_{24}$

Then

$$\mathbf{A} \mathbf{q} = \begin{bmatrix} \mathbf{X}_1^\top & 1 & \mathbf{0}^\top & 0 & -u_1 \mathbf{X}_1^\top & -u_1 \\ \mathbf{0}^\top & 0 & \mathbf{X}_1^\top & 1 & -v_1 \mathbf{X}_1^\top & -v_1 \\ \vdots & & & & \vdots & \\ \mathbf{X}_k^\top & 1 & \mathbf{0}^\top & 0 & -u_k \mathbf{X}_k^\top & -u_k \\ \mathbf{0}^\top & 0 & \mathbf{X}_k^\top & 1 & -v_k \mathbf{X}_k^\top & -v_k \end{bmatrix} \cdot \begin{bmatrix} \mathbf{q}_1 \\ q_{14} \\ \mathbf{q}_2 \\ q_{24} \\ \mathbf{q}_3 \\ q_{34} \end{bmatrix} = \mathbf{0} \quad (9)$$

- we need 11 independent parameters for  $\mathbf{P}$
- $\mathbf{A} \in \mathbb{R}^{2k, 12}$ ,  $\mathbf{q} \in \mathbb{R}^{12}$
- 6 points in a general position give  $\text{rank } \mathbf{A} = 12$  and there is no (non-trivial) null space
- drop one row to get rank-11 matrix, then the basis vector of the null space of  $\mathbf{A}$  gives  $\mathbf{q}$



## ► The Jack-Knife Solution for $k = 6$

- given the 6 correspondences, we have 12 equations for the 11 parameters
- can we use all the information present in the 6 points?

### Jack-knife estimation

1.  $n := 0$
2. for  $i = 1, 2, \dots, 2k$  do
  - a) delete  $i$ -th row from  $\mathbf{A}$ , this gives  $\mathbf{A}_i$
  - b) if  $\dim \text{null } \mathbf{A}_i > 1$  continue with the next  $i$
  - c)  $n := n + 1$
  - d) compute the right null-space  $\mathbf{q}_i$  of  $\mathbf{A}_i$
  - e)  $\hat{\mathbf{q}}_i := \mathbf{q}_i$  normalized to  $q_{34} = 1$  and dimension-reduced
3. from all  $n$  vectors  $\hat{\mathbf{q}}_i$  collected in Step 2.e compute

$$\mathbf{q} = \frac{1}{n} \sum_{i=1}^n \hat{\mathbf{q}}_i, \quad \text{var}[\mathbf{q}] = \frac{n-1}{n} \text{diag} \sum_{i=1}^n (\hat{\mathbf{q}}_i - \mathbf{q})(\hat{\mathbf{q}}_i - \mathbf{q})^\top$$

regular for  $n \geq 11$   
variance of the sample mean

- have a solution + an error estimate, per individual elements of  $\mathbf{P}$  (except  $P_{34}$ )
- at least 5 points must be in a general position ( $\rightarrow 64$ )
- large error indicates near degeneracy
- computation not efficient with  $k > 6$  points, needs  $\binom{2k}{11}$  draws, e.g.  $k = 7 \Rightarrow 364$  draws
- better error estimation method: decompose  $\mathbf{P}_i$  to  $\mathbf{K}_i, \mathbf{R}_i, \mathbf{t}_i$  ( $\rightarrow 33$ ), represent  $\mathbf{R}_i$  with 3 parameters (e.g. Euler angles, or in exponential map representation  $\rightarrow 144$ ) and compute the errors for the parameters
- even better: use the SE(3) Lie group for  $(\mathbf{R}_i, \mathbf{t}_i)$  and average its Lie-algebraic representations



e.g. by 'economy-size' SVD  
assuming finite cam. with  $P_{3,4} = 1$

## ► Degenerate (Critical) Configurations for Camera Resection

Let  $\mathcal{X} = \{X_i; i = 1, \dots\}$  be a set of points and  $\mathbf{P}_1 \neq \mathbf{P}_j$  be two regular (rank-3) cameras. Then two configurations  $(\mathbf{P}_1, \mathcal{X})$  and  $(\mathbf{P}_j, \mathcal{X})$  are image-equivalent if

$$\mathbf{P}_1 \underline{\mathbf{X}}_i \simeq \mathbf{P}_j \underline{\mathbf{X}}_i \quad \text{for all } X_i \in \mathcal{X}$$

there is a non-trivial set of other cameras that see the same image

### Results

- importantly: If all calibration points  $X_i \in \mathcal{X}$  lie on a plane  $\varkappa$  then camera resection is non-unique and all image-equivalent camera centers lie on a spatial line  $\mathcal{C}$  with the  $C_\infty = \varkappa \cap \mathcal{C}$  excluded
- and more: by adding points  $X_i \in \mathcal{X}$  to  $\mathcal{C}$  we gain nothing
- there are additional image-equivalent configurations, see next

this also means we cannot resect if all  $X_i$  are infinite

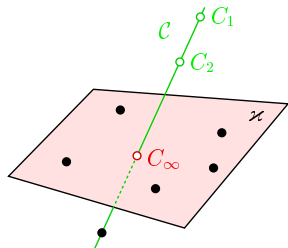

Case 4

Proof sketch: If  $\mathbf{Q}, \mathbf{T}$  are suitable homographies then  $\mathbf{P}_1 \simeq \mathbf{Q}\mathbf{P}_0\mathbf{T}$ , where  $\mathbf{P}_0$  is canonical and the analysis can be made with  $\hat{\mathbf{P}}_j \simeq \mathbf{Q}^{-1}\mathbf{P}_j$

$$\mathbf{P}_0 \underbrace{\underline{\mathbf{T}}\underline{\mathbf{X}}_i}_{\underline{\mathbf{Y}}_i} \simeq \hat{\mathbf{P}}_j \underbrace{\underline{\mathbf{T}}\underline{\mathbf{X}}_i}_{\underline{\mathbf{Y}}_i} \quad \text{for all } Y_i \in \mathcal{Y}$$

see [H&Z, Sec. 22.1.2] for a full proof

## cont'd (all cases)

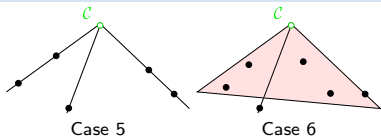

- points lie on three optical rays or one optical ray and one optical plane
- cameras  $C_1, C_2$  co-located at point  $C$
- Case 5: camera sees 3 isolated point images
- Case 6: cam. sees a line of points and an isolated point

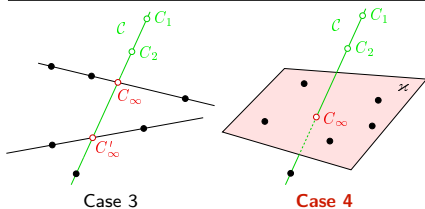

- points lie on a line  $C$  and
  1. on two lines meeting  $C$  at  $C_\infty, C'_\infty$
  2. or on a plane meeting  $C$  at  $C_\infty$
- cameras lie on a line  $C \setminus \{C_\infty, C'_\infty\}$
- Case 3: camera sees 2 lines of points
- Case 4: **dangerous!**

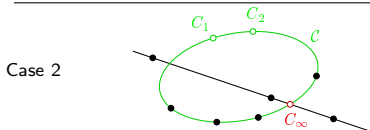

- points lie on a planar conic  $C$  and an additional line meeting  $C$  at  $C_\infty$
- cameras lie on  $C \setminus \{C_\infty\}$  not necessarily an ellipse
- Case 2: camera sees 2 lines of points

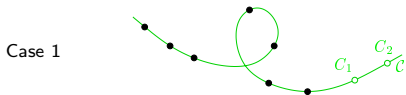

- points and cameras all lie on a twisted cubic  $C$
- Case 1: camera sees points on a conic  
dangerous but unlikely to occur

## ► Three-Point Exterior Orientation Problem (P3P)

Calibrated camera rotation and translation from Perspective images of 3 reference Points.

**Problem:** Given  $\mathbf{K}$  and three corresponding pairs  $\{(m_i, X_i)\}_{i=1}^3$ , find  $\mathbf{R}$ ,  $\mathbf{C}$  by solving

$$\lambda_i \underline{\mathbf{m}}_i = \mathbf{K}\mathbf{R}(\mathbf{X}_i - \mathbf{C}), \quad i = 1, 2, 3 \quad \mathbf{X}_i \text{ Cartesian}$$

1. Transform  $\underline{\mathbf{v}}_i \stackrel{\text{def}}{=} \mathbf{K}^{-1}\underline{\mathbf{m}}_i$ . Then

$$\lambda_i \underline{\mathbf{v}}_i = \mathbf{R}(\mathbf{X}_i - \mathbf{C}). \quad (10)$$

2. If there was no rotation in (10), the situation would look like this

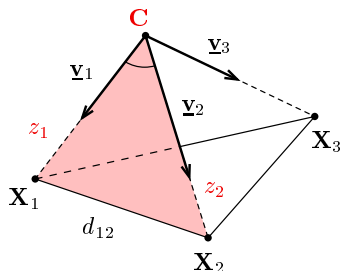

3. and we could shoot 3 lines from the given points  $\mathbf{X}_i$  in given directions  $\underline{\mathbf{v}}_i$  to get  $\mathbf{C}$
4. given  $\mathbf{C}$  we solve (10) for  $\lambda_i$ ,  $\mathbf{R}$

## ► P3P cont'd

### If there is rotation $\mathbf{R}$

1. Eliminate  $\mathbf{R}$  by taking

rotation preserves length:  $\|\mathbf{R}\mathbf{x}\| = \|\mathbf{x}\|$

$$|\lambda_i| \cdot \|\mathbf{v}_i\| = \|\mathbf{X}_i - \mathbf{C}\| \stackrel{\text{def}}{=} z_i \quad (11)$$

2. Consider only angles among  $\mathbf{v}_i$  and apply Cosine Law per triangle  $(\mathbf{C}, \mathbf{X}_i, \mathbf{X}_j)$   $i, j = 1, 2, 3, i \neq j$

$$d_{ij}^2 = z_i^2 + z_j^2 - 2 z_i z_j c_{ij},$$

$$z_i = \|\mathbf{X}_i - \mathbf{C}\|, \quad d_{ij} = \|\mathbf{X}_j - \mathbf{X}_i\|, \quad c_{ij} = \cos(\angle \mathbf{v}_i \mathbf{v}_j)$$

4. Solve the system of 3 quadratic eqs in 3 unknowns  $z_i$

[Fischler & Bolles, 1981]

there may be no real root

there are up to 4 solutions that cannot be ignored (verify on additional points)

5. Compute  $\mathbf{C}$  by trilateration (3-sphere intersection) from  $\mathbf{X}_i$  and  $z_i$ ; then  $\lambda_i$  from (11)

6. Compute  $\mathbf{R}$  from (10)

we will solve this problem next  $\rightarrow 70$

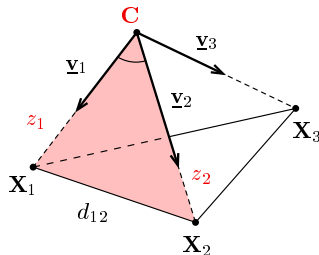

Similar problems (P4P with unknown  $f$ ) at <http://aag.ciirc.cvut.cz/minimal/> (papers, code)

## Degenerate (Critical) Configurations for Exterior Orientation

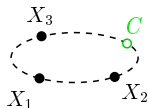

### no solution

1.  $C$  cocyclic with  $(X_1, X_2, X_3)$

camera sees points on a line

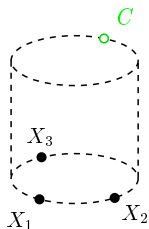

### unstable solution

- center of projection  $C$  located on the orthogonal circular cylinder with base circumscribing the three points  $X_i$

unstable: a small change of  $X_i$  results in a large change of  $C$

can be detected by error propagation

### degenerate

- camera  $C$  is coplanar with points  $(X_1, X_2, X_3)$  but is not on the circumscribed circle of  $(X_1, X_2, X_3)$

camera sees points on a line

- additional critical configurations depend on the quadratic equations solver

[Haralick et al. IJCV 1994]

## ► Populating A Little ZOO of Minimal Geometric Problems in CV

problem	given	unknown	slide
camera resection	6 world–image correspondences $\{(X_i, m_i)\}_{i=1}^6$	<b>P</b>	→62
exterior orientation	<b>K</b> , 3 world–image correspondences $\{(X_i, m_i)\}_{i=1}^3$	<b>R, C</b>	→66
relative orientation	3 world–world correspondences $\{(X_i, Y_i)\}_{i=1}^3$	<b>R, t</b>	→70

- camera resection and exterior orientation are similar problems in a sense:
  - we do resectioning when our camera is uncalibrated
  - we do orientation when our camera is calibrated
- relative orientation involves no camera (see next)
- more problems to come

it is a recurring problem in 3D vision

## ► The Relative Orientation Problem

**Problem:** Given point triples  $(X_1, X_2, X_3)$  and  $(Y_1, Y_2, Y_3)$  in a general position in  $\mathbf{R}^3$  such that the correspondence  $X_i \leftrightarrow Y_i$  is known, determine the relative orientation  $(\mathbf{R}, \mathbf{t})$  that maps  $\mathbf{X}_i$  to  $\mathbf{Y}_i$ , i.e.

$$\mathbf{Y}_i = \mathbf{R}\mathbf{X}_i + \mathbf{t}, \quad i = 1, 2, 3.$$

**Applies to:**

- 3D scanners
- merging partial reconstructions from different viewpoints
- generalization of the last step of P3P

**Obs:** Let the centroid be  $\bar{\mathbf{X}} = \frac{1}{3} \sum_i \mathbf{X}_i$  and analogically for  $\bar{\mathbf{Y}}$ . Then

$$\bar{\mathbf{Y}} = \mathbf{R}\bar{\mathbf{X}} + \mathbf{t}.$$

Therefore

$$\mathbf{Z}_i \stackrel{\text{def}}{=} (\mathbf{Y}_i - \bar{\mathbf{Y}}) = \mathbf{R}(\mathbf{X}_i - \bar{\mathbf{X}}) \stackrel{\text{def}}{=} \mathbf{R}\mathbf{W}_i$$

If all dot products are equal,  $\mathbf{Z}_i^\top \mathbf{Z}_j = \mathbf{W}_i^\top \mathbf{W}_j$  for  $i, j = 1, 2, 3$ , we have

$$\mathbf{R}^* = [\mathbf{W}_1 \quad \mathbf{W}_2 \quad \mathbf{W}_3]^{-1} [\mathbf{Z}_1 \quad \mathbf{Z}_2 \quad \mathbf{Z}_3]$$

**Poor man's solver:**

- normalize  $\mathbf{W}_i, \mathbf{Z}_i$  to unit length, use the above formula, and then find the closest rotation matrix
- but this is equivalent to a non-optimal objective it ignores errors in vector lengths



# An Optimal Algorithm for Relative Orientation

We setup a minimization problem

$$\mathbf{R}^* = \arg \min_{\mathbf{R}} \sum_{i=1}^3 \|\mathbf{Z}_i - \mathbf{R}\mathbf{W}_i\|^2 \quad \text{s.t.} \quad \mathbf{R}^\top \mathbf{R} = \mathbf{I}, \quad \det \mathbf{R} = 1$$

$$\arg \min_{\mathbf{R}} \sum_i \|\mathbf{Z}_i - \mathbf{R}\mathbf{W}_i\|^2 = \arg \min_{\mathbf{R}} \sum_i \left( \|\mathbf{Z}_i\|^2 - 2\mathbf{Z}_i^\top \mathbf{R}\mathbf{W}_i + \|\mathbf{W}_i\|^2 \right) = \dots = \arg \max_{\mathbf{R}} \sum_i \mathbf{Z}_i^\top \mathbf{R}\mathbf{W}_i$$

**Obs 1:** Let  $\mathbf{A} : \mathbf{B} = \sum_{i,j} a_{ij}b_{ij}$  be the dot-product (Frobenius inner product) over real matrices. Then

$$\mathbf{A} : \mathbf{B} = \mathbf{B} : \mathbf{A} = \text{tr}(\mathbf{A}^\top \mathbf{B}) = \text{vec}(\mathbf{A})^\top \text{vec}(\mathbf{B}) = \mathbf{a} \cdot \mathbf{b}$$

**Obs 2:** (cyclic property for matrix trace)

$$\text{tr}(\mathbf{ABC}) = \text{tr}(\mathbf{CAB})$$

**Obs 3:** ( $\mathbf{Z}_i, \mathbf{W}_i$  are vectors)

$$\mathbf{Z}_i^\top \mathbf{R}\mathbf{W}_i = \text{tr}(\mathbf{Z}_i^\top \mathbf{R}\mathbf{W}_i) \stackrel{\text{O2}}{=} \text{tr}(\mathbf{W}_i \mathbf{Z}_i^\top \mathbf{R}) \stackrel{\text{O1}}{=} (\mathbf{Z}_i \mathbf{W}_i^\top) : \mathbf{R} = \mathbf{R} : (\mathbf{Z}_i \mathbf{W}_i^\top)$$

Let there be SVD of

$$\sum_i \mathbf{Z}_i \mathbf{W}_i^\top \stackrel{\text{def}}{=} \mathbf{M} = \mathbf{U}\mathbf{D}\mathbf{V}^\top$$

Then

$$\mathbf{R} : \mathbf{M} = \mathbf{R} : (\mathbf{U}\mathbf{D}\mathbf{V}^\top) \stackrel{\text{O1}}{=} \text{tr}(\mathbf{R}^\top \mathbf{U}\mathbf{D}\mathbf{V}^\top) \stackrel{\text{O2}}{=} \text{tr}(\mathbf{V}^\top \mathbf{R}^\top \mathbf{U}\mathbf{D}) \stackrel{\text{O1}}{=} (\mathbf{U}^\top \mathbf{R}\mathbf{V}) : \mathbf{D}$$

We are solving

$$\mathbf{R}^* = \arg \max_{\mathbf{R}} \sum_i \mathbf{z}_i^\top \mathbf{R} \mathbf{W}_i = \arg \max_{\mathbf{R}} \left( \mathbf{U}^\top \mathbf{R} \mathbf{V} \right) : \mathbf{D}$$

**A particular solution is found as follows:**

- $\mathbf{U}^\top \mathbf{R} \mathbf{V}$  must be (1) orthogonal, and closest to: (2) diagonal and (3) positive definite  $\mathbf{D}$
- Since  $\mathbf{U}$ ,  $\mathbf{V}$  are orthogonal matrices then the solution to the problem is among  $\mathbf{R}^* = \mathbf{U} \mathbf{S} \mathbf{V}^\top$ , where  $\mathbf{S}$  is diagonal and orthogonal, i.e. one of

$$\pm \text{diag}(1, 1, 1), \quad \pm \text{diag}(1, -1, -1), \quad \pm \text{diag}(-1, 1, -1), \quad \pm \text{diag}(-1, -1, 1)$$

- $\mathbf{U}^\top \mathbf{V}$  is not necessarily positive definite
- We choose  $\mathbf{S}$  so that  $(\mathbf{R}^*)^\top \mathbf{R}^* = \mathbf{I}$

**Alg:**

1. Compute matrix  $\mathbf{M} = \sum_i \mathbf{z}_i \mathbf{W}_i^\top$ .
2. Compute SVD  $\mathbf{M} = \mathbf{U} \mathbf{D} \mathbf{V}^\top$ .
3. Compute all  $\mathbf{R}_k = \mathbf{U} \mathbf{S}_k \mathbf{V}^\top$  that give  $\mathbf{R}_k^\top \mathbf{R}_k = \mathbf{I}$ .
4. Compute  $\mathbf{t}_k = \tilde{\mathbf{Y}} - \mathbf{R}_k \tilde{\mathbf{X}}$ .

- The algorithm can be used for more than 3 points
- Triple pairs can be pre-filtered based on motion invariants (lengths, angles)
- Can be used for the last step of the exterior orientation (P3P) problem →66

## Computing with a Camera Pair

- 4.1 Camera Motions Inducing Epipolar Geometry, Fundamental and Essential Matrices
- 4.2 Estimating Fundamental Matrix from 7 Correspondences
- 4.3 Estimating Essential Matrix from 5 Correspondences
- 4.4 Triangulation: 3D Point Position from a Pair of Corresponding Points

### covered by

- [1] [H&Z] Secs: 9.1, 9.2, 9.6, 11.1, 11.2, 11.9, 12.2, 12.3, 12.5.1
- [2] H. Li and R. Hartley. Five-point motion estimation made easy. In *Proc ICPR 2006*, pp. 630–633

### additional references



H. Longuet-Higgins. A computer algorithm for reconstructing a scene from two projections. *Nature*, 293(5828):133–135, 1981.

## ► Geometric Model of a Camera Stereo Pair

$$\mathbf{P}_i = [\mathbf{Q}_i \quad \mathbf{q}_i] = \mathbf{K}_i [\mathbf{R}_i \quad \mathbf{t}_i] = \mathbf{K}_i \mathbf{R}_i [\mathbf{I} \quad -\mathbf{C}_i] \quad i = 1, 2 \quad \rightarrow 31$$

### Epipolar geometry:

- brings constraints necessary for inter-image matching
- its parametric form encapsulates information about the relative pose of two cameras

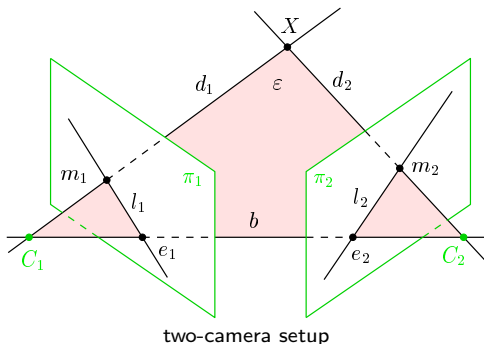

### Description

- baseline  $b$  joins projection centers  $C_1, C_2$

$$\mathbf{b} = \mathbf{C}_2 - \mathbf{C}_1$$

- epipole  $e_i \in \pi_i$  is the image of  $C_j$ :

$$\mathbf{e}_1 \simeq \mathbf{P}_1 \mathbf{C}_2, \quad \mathbf{e}_2 \simeq \mathbf{P}_2 \mathbf{C}_1$$

- $l_i \in \pi_i$  is the image of optical ray  $d_j, j \neq i$  and also the epipolar plane

$$\varepsilon = (C_2, X, C_1)$$

- $l_j$  is the epipolar line ('epipolar') in image  $\pi_i$  induced by  $m_i$  in image  $\pi_i$

Epipolar constraint relates  $\underline{m}_1$  and  $\underline{m}_2$ : corresponding  $d_2, b, d_1$  are coplanar

a necessary condition  $\rightarrow 87$

# Epipolar Geometry Example: Forward Motion

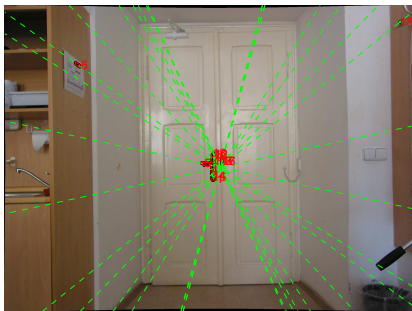

image 1

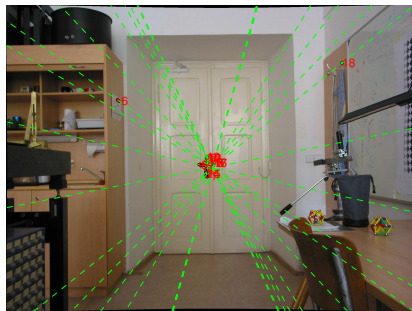
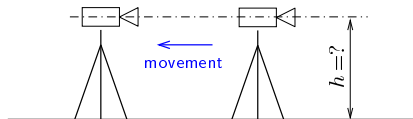

image 2

- red: correspondences
- green: epipolar line pairs per correspondence

[click on the image to see their IDs](#)  
[same ID in both images](#)

Epipole is the image of the other camera's center.  
How high was the camera above the floor?



## ► Cross Products and Maps by Skew-Symmetric $3 \times 3$ Matrices

- There is an equivalence  $\mathbf{b} \times \mathbf{m} = [\mathbf{b}]_{\times} \mathbf{m}$ , where  $[\mathbf{b}]_{\times}$  is a  $3 \times 3$  skew-symmetric matrix

$$[\mathbf{b}]_{\times} = \begin{bmatrix} 0 & -b_3 & b_2 \\ b_3 & 0 & -b_1 \\ -b_2 & b_1 & 0 \end{bmatrix}, \quad \text{assuming } \mathbf{b} = \begin{bmatrix} b_1 \\ b_2 \\ b_3 \end{bmatrix}$$

### Some properties

1.  $[\mathbf{b}]_{\times}^{\top} = -[\mathbf{b}]_{\times}$  the general antisymmetry property
2.  $\mathbf{A}$  is skew-symmetric iff  $\mathbf{x}^{\top} \mathbf{A} \mathbf{x} = 0$  for all  $\mathbf{x}$  skew-sym mtx generalizes cross products
3.  $[\mathbf{b}]_{\times}^3 = -\|\mathbf{b}\|^2 \cdot [\mathbf{b}]_{\times}$
4.  $\|[\mathbf{b}]_{\times}\|_F = \sqrt{2} \|\mathbf{b}\|$  Frobenius norm ( $\|\mathbf{A}\|_F = \sqrt{\text{tr}(\mathbf{A}^{\top} \mathbf{A})} = \sqrt{\sum_{i,j} |a_{ij}|^2}$ )
5.  $\text{rank} [\mathbf{b}]_{\times} = 2$  iff  $\|\mathbf{b}\| > 0$  check minors of  $[\mathbf{b}]_{\times}$
6.  $[\mathbf{b}]_{\times} \mathbf{b} = \mathbf{0}$
7. eigenvalues of  $[\mathbf{b}]_{\times}$  are  $(0, \lambda, -\lambda)$
8. for any  $3 \times 3$  regular  $\mathbf{B}$ :  $\mathbf{B}^{\top} [\mathbf{Bz}]_{\times} \mathbf{B} = \det \mathbf{B} [\mathbf{z}]_{\times}$  follows from the factoring on  $\rightarrow 39$
9. in particular: if  $\mathbf{R} \mathbf{R}^{\top} = \mathbf{I}$  then  $[\mathbf{Rb}]_{\times} = \mathbf{R} [\mathbf{b}]_{\times} \mathbf{R}^{\top}$ 
  - note that if  $\mathbf{R}_b$  is rotation about  $\mathbf{b}$  then  $\mathbf{R}_b \mathbf{b} = \mathbf{b}$
  - note  $[\mathbf{b}]_{\times}$  is not a homography; it is not a rotation matrix it is the logarithm of a rotation mtx

## ► Expressing Epipolar Constraint Algebraically

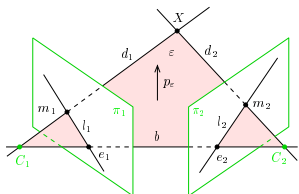

$$\mathbf{P}_i = [\mathbf{Q}_i \quad \mathbf{q}_i] = \mathbf{K}_i [\mathbf{R}_i \quad \mathbf{t}_i], \quad i = 1, 2$$

defs:

$\mathbf{R}_{21}$  – relative camera rotation,  $\mathbf{R}_{21} = \mathbf{R}_2 \mathbf{R}_1^\top$

$\mathbf{t}_{21}$  – relative camera translation,  $\mathbf{t}_{21} = \mathbf{t}_2 - \mathbf{R}_{21} \mathbf{t}_1 = -\mathbf{R}_2 \mathbf{b} \rightarrow 74$

$\mathbf{b}$  – baseline vector (world coordinate system)

remember:  $\mathbf{C} = -\mathbf{Q}^{-1} \mathbf{q} = -\mathbf{R}^\top \mathbf{t}$

→33 and 35

$$0 = \underbrace{\mathbf{d}_2^\top}_{\text{normal of } \varepsilon} \underbrace{\mathbf{p}_\varepsilon}_{\text{optical ray}} \simeq \underbrace{(\mathbf{Q}_2^{-1} \mathbf{m}_2)^\top}_{\text{optical plane}} \underbrace{\mathbf{Q}_1^\top \mathbf{l}_1}_{\text{optical plane}} = \underbrace{\mathbf{m}_2^\top}_{\text{image of } \varepsilon \text{ in } \pi_2} \underbrace{\mathbf{Q}_2^{-\top} \mathbf{Q}_1^\top (\mathbf{e}_1 \times \mathbf{m}_1)}_{\text{fundamental matrix } \mathbf{F}} \mathbf{m}_1$$

**Epipolar constraint**  $\mathbf{m}_2^\top \mathbf{F} \mathbf{m}_1 = 0$  is a point-line incidence constraint

- point  $\mathbf{m}_2$  is incident on epipolar line  $\mathbf{l}_2 \simeq \mathbf{F} \mathbf{m}_1$
- point  $\mathbf{m}_1$  is incident on epipolar line  $\mathbf{l}_1 \simeq \mathbf{F}^\top \mathbf{m}_2$
- $\mathbf{F} \mathbf{e}_1 = \mathbf{F}^\top \mathbf{e}_2 = \mathbf{0}$  (non-trivially)
- all epipolars meet at the epipole

$$\mathbf{e}_1 \simeq \mathbf{Q}_1 \mathbf{C}_2 + \mathbf{q}_1 = \mathbf{Q}_1 \mathbf{C}_2 - \mathbf{Q}_1 \mathbf{C}_1 = \mathbf{K}_1 \mathbf{R}_1 \mathbf{b} = -\mathbf{K}_1 \mathbf{R}_1 \mathbf{R}_2^\top \mathbf{t}_{21} = -\mathbf{K}_1 \mathbf{R}_{21}^\top \mathbf{t}_{21}$$

$$\mathbf{F} = \mathbf{Q}_2^{-\top} \mathbf{Q}_1^\top [\mathbf{e}_1]_\times = \mathbf{Q}_2^{-\top} \mathbf{Q}_1^\top [-\mathbf{K}_1 \mathbf{R}_{21}^\top \mathbf{t}_{21}]_\times = \dots \simeq \mathbf{K}_2^{-\top} [-\mathbf{t}_{21}]_\times \mathbf{R}_{21} \mathbf{K}_1^{-1} \text{ fundamental}$$

$$\mathbf{E} = [-\mathbf{t}_{21}]_\times \mathbf{R}_{21} = \underbrace{[\mathbf{R}_2 \mathbf{b}]_\times}_{\text{baseline in Cam 2}} \mathbf{R}_{21} \stackrel{\rightarrow 76/9}{=} \mathbf{R}_{21} \underbrace{[\mathbf{R}_1 \mathbf{b}]_\times}_{\text{baseline in Cam 1}} = \mathbf{R}_{21} [-\mathbf{R}_{21}^\top \mathbf{t}_{21}]_\times \text{ essential}$$

## ► The Structure and the Key Properties of the Fundamental Matrix

$$\mathbf{F} = \underbrace{(\mathbf{Q}_2 \mathbf{Q}_1^{-1})^{-\top}}_{\text{epipolar homography } \mathbf{H}_e} [\mathbf{e}_1]_{\times} = \underbrace{\mathbf{K}_2^{-\top} \mathbf{R}_{21} \mathbf{K}_1^{\top}}_{\mathbf{H}_e^{-\top}} \overbrace{[\mathbf{e}_1]_{\times}}^{\text{left epipole}} \xrightarrow{76} \overbrace{[\mathbf{H}_e \mathbf{e}_1]_{\times}}^{\text{right epipole}} \mathbf{H}_e = \mathbf{K}_2^{-\top} \underbrace{[-\mathbf{t}_{21}]_{\times} \mathbf{R}_{21} \mathbf{K}_1^{-1}}_{\text{essential matrix } \mathbf{E}}$$

1. the epipole  $\mathbf{e}_1$  falls in the nullspace of  $\mathbf{F}$ :  $\mathbf{F} \mathbf{e}_1 = \mathbf{H}_e^{-\top} [\mathbf{e}_1]_{\times} \mathbf{e}_1 = \mathbf{0}$ , also  $\mathbf{e}_2^{\top} \mathbf{F} = \mathbf{0}$
2.  $\mathbf{E}$  captures relative camera pose only

[Longuet-Higgins 1981]

(the change of the world coordinate system does not change  $\mathbf{E}$ )

$$[\mathbf{R}'_i \quad \mathbf{t}'_i] = [\mathbf{R}_i \quad \mathbf{t}_i] \cdot \begin{bmatrix} \mathbf{R} & \mathbf{t} \\ \mathbf{0}^{\top} & 1 \end{bmatrix} = [\mathbf{R}_i \mathbf{R} \quad \mathbf{R}_i \mathbf{t} + \mathbf{t}_i],$$

then

$$\mathbf{R}'_{21} = \mathbf{R}'_2 \mathbf{R}'_1{}^{\top} = \dots = \mathbf{R}_{21}$$

$$\mathbf{t}'_{21} = \mathbf{t}'_2 - \mathbf{R}'_{21} \mathbf{t}'_1 = \dots = \mathbf{t}_{21}$$

3. the translation length  $\mathbf{t}_{21}$  is lost since  $\mathbf{E}$  is homogeneous
4.  $\mathbf{F}$  maps points to lines and it is not a homography
5.  $\mathbf{H}_e$  maps epipoles to epipoles,  $\mathbf{H}_e^{-\top}$  epipolar lines to epipolar lines:  $\mathbf{l}_2 \simeq \mathbf{H}_e^{-\top} \mathbf{l}_1$

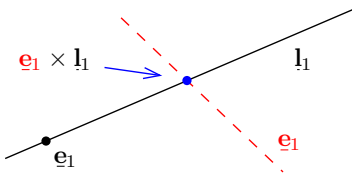

**another epipolar line map:**  $\mathbf{l}_2 \simeq \mathbf{F}[\mathbf{e}_1]_{\times} \mathbf{l}_1 = \mathbf{F}(\mathbf{e}_1 \times \mathbf{l}_1)$

- proof by point/line 'transmutation' (left)
- point  $\mathbf{e}_1$  does not lie on line  $\mathbf{e}_1$  (dashed):  $\mathbf{e}_1^{\top} \mathbf{e}_1 \neq 0$
- $\mathbf{F}[\mathbf{e}_1]_{\times}$  is not a homography, unlike  $\mathbf{H}_e^{-\top}$  but it does the same job for epipolar line mapping
- no need to decompose  $\mathbf{F}$  to obtain  $\mathbf{H}_e$



## ► Summary: Relations and Mappings Involving Fundamental Matrix

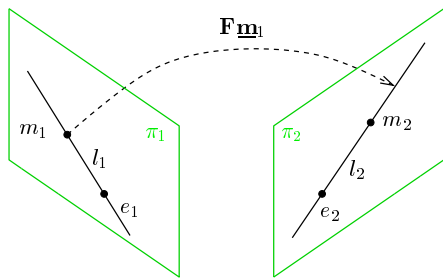

$$0 = \underline{m}_2^T \mathbf{F} \underline{m}_1$$

$$\underline{e}_1 \simeq \text{null}(\mathbf{F}),$$

$$\underline{e}_2 \simeq \text{null}(\mathbf{F}^T)$$

$$\underline{e}_1 \simeq \mathbf{H}_e^{-1} \underline{e}_2$$

$$\underline{e}_2 \simeq \mathbf{H}_e \underline{e}_1$$

$$\underline{l}_1 \simeq \mathbf{F}^T \underline{m}_2$$

$$\underline{l}_2 \simeq \mathbf{F} \underline{m}_1$$

$$\underline{l}_1 \simeq \mathbf{H}_e^T \underline{l}_2$$

$$\underline{l}_2 \simeq \mathbf{H}_e^{-T} \underline{l}_1$$

$$\underline{l}_1 \simeq \mathbf{F}^T [\underline{e}_2]_{\times} \underline{l}_2$$

$$\underline{l}_2 \simeq \mathbf{F} [\underline{e}_1]_{\times} \underline{l}_1$$

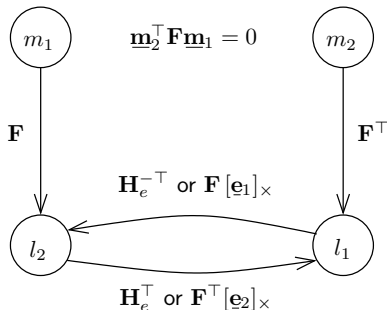

- $\mathbf{F}[\underline{e}_1]_{\times}$  maps epipolar lines to epipolar lines but it is not a homography
- $\mathbf{H}_e = \mathbf{Q}_2 \mathbf{Q}_1^{-1}$  is the epipolar homography → 78  
 $\mathbf{H}_e^{-T}$  maps epipolar lines to epipolar lines, where

$$\mathbf{H}_e = \mathbf{Q}_2 \mathbf{Q}_1^{-1} = \mathbf{K}_2 \mathbf{R}_{21} \mathbf{K}_1^{-1}$$

you have seen this → 59

## ► Representation Theorem for Fundamental Matrices

**Def:**  $\mathbf{F}$  is fundamental when  $\mathbf{F} \simeq \mathbf{H}^{-\top}[\mathbf{e}_1]_{\times}$ , where  $\mathbf{H}$  is regular and  $\mathbf{e}_1 \simeq \text{null } \mathbf{F} \neq \mathbf{0}$ .

**Theorem:** A  $3 \times 3$  matrix  $\mathbf{A}$  is fundamental iff it is of rank 2.

**Proof.**

Direct: By the geometry,  $\mathbf{H}$  is full-rank,  $\mathbf{e}_1 \neq \mathbf{0}$ , hence  $\mathbf{H}^{-\top}[\mathbf{e}_1]_{\times}$  is a  $3 \times 3$  matrix of rank 2.

Converse:

1. let  $\mathbf{A} = \mathbf{U}\mathbf{D}\mathbf{V}^{\top}$  be the SVD of  $\mathbf{A}$  of rank 2; then  $\mathbf{D} = \text{diag}(\lambda_1, \lambda_2, 0)$ ,  $\lambda_1 \geq \lambda_2 > 0$

2. we write  $\mathbf{D} = \mathbf{B}\mathbf{C}$ , where  $\mathbf{B} = \text{diag}(\lambda_1, \lambda_2, \lambda_3)$ ,  $\mathbf{C} = \text{diag}(1, 1, 0)$ ,  $\lambda_3 > 0$

3. then  $\mathbf{A} = \mathbf{U}\mathbf{B}\mathbf{C}\mathbf{V}^{\top} = \mathbf{U}\mathbf{B}\underbrace{\mathbf{W}\mathbf{W}^{\top}}_{\mathbf{I}}\mathbf{V}^{\top}$  with  $\mathbf{W}$  rotation matrix

4. we look for a rotation mtr  $\mathbf{W}$  that maps  $\mathbf{C}$  to a skew-symmetric  $\mathbf{S}$ , i.e.  $\mathbf{S} = \mathbf{C}\mathbf{W}$ , if any

5. then  $\mathbf{W} = \begin{bmatrix} 0 & \alpha & 0 \\ -\alpha & 0 & 0 \\ 0 & 0 & 1 \end{bmatrix}$ ,  $|\alpha| = 1$ , and  $\mathbf{S} = \mathbf{C}\mathbf{W} = \begin{bmatrix} 1 & 0 & 0 \\ 0 & 1 & 0 \\ 0 & 0 & 0 \end{bmatrix} \begin{bmatrix} 0 & \alpha & 0 \\ -\alpha & 0 & 0 \\ 0 & 0 & 1 \end{bmatrix} = \dots = [\mathbf{s}]_{\times}$ , where  $\mathbf{s} = (0, 0, 1)$

6. we write

$\mathbf{v}_3$  – 3rd column of  $\mathbf{V}$ ,  $\mathbf{u}_3$  – 3rd column of  $\mathbf{U}$

$$\mathbf{A} = \mathbf{U}\mathbf{B}[\mathbf{s}]_{\times}\mathbf{W}^{\top}\mathbf{V}^{\top} = \overset{\textcircled{*}}{\dots} \mathbf{1} = \underbrace{\mathbf{U}\mathbf{B}(\mathbf{V}\mathbf{W})^{\top}}_{\simeq \mathbf{H}^{-\top}} [\mathbf{v}_3]_{\times} \stackrel{\rightarrow 76/9}{\simeq} \underbrace{[\mathbf{H}\mathbf{v}_3]_{\times}}_{\simeq [\mathbf{u}_3]_{\times}} \mathbf{H}, \quad (12)$$

7.  $\mathbf{H}$  regular,  $\mathbf{A}\mathbf{v}_3 = \mathbf{0}$ ,  $\mathbf{u}_3\mathbf{A} = \mathbf{0}$  for  $\mathbf{v}_3 \neq \mathbf{0}$ ,  $\mathbf{u}_3 \neq \mathbf{0}$  □

• we also got a (non-unique:  $\alpha, \lambda_3$ ) decomposition formula for fundamental matrices

• it follows there is no constraint on  $\mathbf{F}$  except for the rank

## ► Representation Theorem for Essential Matrices

### Theorem

Let  $\mathbf{E}$  be a  $3 \times 3$  matrix with SVD  $\mathbf{E} = \mathbf{U}\mathbf{D}\mathbf{V}^\top$ . Then  $\mathbf{E}$  is essential iff  $\mathbf{D} \simeq \text{diag}(1, 1, 0)$ .

### Proof.

Direct:

If  $\mathbf{E}$  is an essential matrix, then the epipolar homography matrix is a rotation matrix ( $\rightarrow 78$ ), hence  $\mathbf{H}^{-\top} \simeq \mathbf{U}\mathbf{B}(\mathbf{V}\mathbf{W})^\top$  in (12) must be (1) diagonal, and (2) ( $\lambda$ -scaled) orthogonal.

It follows  $\mathbf{B} = \lambda\mathbf{I}$ .

note this fixed the missing  $\lambda_3$  in (12)

Then

$$\mathbf{R}_{21} = \mathbf{H}^{-\top} \simeq \mathbf{U}\mathbf{W}^\top \mathbf{V}^\top \simeq \mathbf{U}\mathbf{W}\mathbf{V}^\top$$

Converse:

$\mathbf{E}$  is fundamental with

$$\mathbf{D} = \text{diag}(\lambda, \lambda, 0) = \underbrace{\lambda\mathbf{I}}_{\mathbf{B}} \underbrace{\text{diag}(1, 1, 0)}_{\mathbf{D}}$$

then  $\mathbf{B} = \lambda\mathbf{I}$  in (12) and  $\mathbf{U}(\mathbf{V}\mathbf{W})^\top$  is orthogonal, as required.  $\square$

## ► Essential Matrix Decomposition

We are decomposing  $\mathbf{E}$  to  $\mathbf{E} \simeq [\mathbf{u}_3]_{\times} \mathbf{H} \simeq [-\mathbf{t}_{21}]_{\times} \mathbf{R}_{21} = \mathbf{R}_{21} [-\mathbf{R}_{21}^{\top} \mathbf{t}_{21}]_{\times} \simeq \mathbf{H}^{-\top} [\mathbf{v}_3]_{\times}$  [H&Z, sec. 9.6]

1. compute SVD of  $\mathbf{E} = \mathbf{U} \mathbf{D} \mathbf{V}^{\top}$  and verify  $\mathbf{D} = \lambda \text{diag}(1, 1, 0)$
2. ensure  $\mathbf{U}$ ,  $\mathbf{V}$  are rotation matrices by  $\mathbf{U} \mapsto \det(\mathbf{U})\mathbf{U}$ ,  $\mathbf{V} \mapsto \det(\mathbf{V})\mathbf{V}$
3. compute

$$\mathbf{R}_{21} = \underbrace{\mathbf{U} \begin{bmatrix} 0 & \alpha & 0 \\ -\alpha & 0 & 0 \\ 0 & 0 & 1 \end{bmatrix} \mathbf{V}^{\top}}_{\mathbf{W}}, \quad \mathbf{t}_{21} \stackrel{(12)}{=} -\beta \mathbf{u}_3, \quad |\alpha| = 1, \quad \beta \neq 0 \quad (13)$$

### Notes

- $\mathbf{v}_3 \simeq \mathbf{R}_{21}^{\top} \mathbf{t}_{21}$  by (12), hence  $\mathbf{R}_{21} \mathbf{v}_3 \simeq \mathbf{t}_{21} \simeq \mathbf{u}_3$  since it must fall in left null space by  $\mathbf{E} \simeq [\mathbf{u}_3]_{\times} \mathbf{R}_{21}$
- $\mathbf{t}_{21}$  is recoverable up to scale  $\beta$  and direction  $\text{sign} \beta$
- the result for  $\mathbf{R}_{21}$  is unique up to  $\alpha = \pm 1$  despite non-uniqueness of SVD
- the change of sign in  $\alpha$  rotates the solution by  $180^\circ$  about  $\mathbf{t}_{21}$

$\mathbf{R}(\alpha) = \mathbf{U} \mathbf{W} \mathbf{V}^{\top} \Rightarrow \mathbf{R}(-\alpha) = \mathbf{U} \mathbf{W}^{\top} \mathbf{V}^{\top} \Rightarrow \mathbf{T} = \mathbf{R}(-\alpha) \mathbf{R}^{\top}(\alpha) = \dots = \mathbf{U} \text{diag}(-1, -1, 1) \mathbf{U}^{\top}$   
which is a rotation by  $180^\circ$  about  $\mathbf{u}_3 \simeq \mathbf{t}_{21}$ : show that  $\mathbf{u}_3$  is the rotation axis

$$\mathbf{U} \text{diag}(-1, -1, 1) \mathbf{U}^{\top} \mathbf{u}_3 = \mathbf{U} \begin{bmatrix} -1 & 0 & 0 \\ 0 & -1 & 0 \\ 0 & 0 & 1 \end{bmatrix} \begin{bmatrix} 0 \\ 0 \\ 1 \end{bmatrix} = \mathbf{u}_3$$

- 4 solution sets for 4 sign combinations of  $\alpha$ ,  $\beta$  see next for geometric interpretation

## ► Four Solutions to Essential Matrix Decomposition

Transform the world coordinate system so that the origin is in Camera 2. Then  $t_{21} = -\mathbf{b}$  and  $\mathbf{W}$  rotates about the baseline  $\mathbf{b}$ .

→77

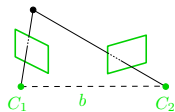

$\alpha, \beta$  front – front

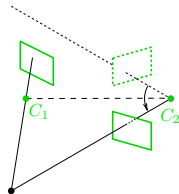

$-\alpha, \beta$  (twisted by  $\mathbf{W}$ ) back – front

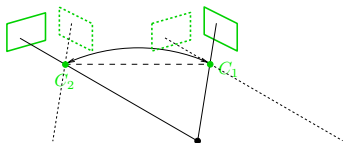

$\alpha, -\beta$  (baseline reversal) back – back

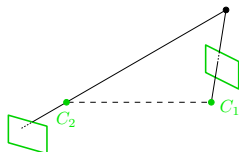

$-\alpha, -\beta$  (combination of both) back – front

### How to disambiguate?

- use the chirality constraint: all 3D points are in front of both cameras
- this singles-out the upper left case: front-front

[H&Z, Sec. 9.6.3]

## ►7-Point Algorithm for Estimating Fundamental Matrix

**Problem:** Given a set  $\{(x_i, y_i)\}_{i=1}^k$  of  $k = 7$  finite correspondences, estimate f. m.  $\mathbf{F}$ .

$$\underline{\mathbf{y}}_i^\top \mathbf{F} \underline{\mathbf{x}}_i = 0, \quad i = 1, \dots, k, \quad \text{known: } \underline{\mathbf{x}}_i = (u_i^1, v_i^1, 1), \quad \underline{\mathbf{y}}_i = (u_i^2, v_i^2, 1)$$

terminology: correspondence = truth, later: match = algorithm's result; hypothesized corresp.

**Solution:**

$$\underline{\mathbf{y}}_i^\top \mathbf{F} \underline{\mathbf{x}}_i = (\underline{\mathbf{y}}_i \underline{\mathbf{x}}_i^\top) : \mathbf{F} = (\text{vec}(\underline{\mathbf{y}}_i \underline{\mathbf{x}}_i^\top))^\top \text{vec}(\mathbf{F}), \quad \text{rotation property of matrix trace} \rightarrow 71$$

$$\text{vec}(\mathbf{F}) = [f_{11} \quad f_{21} \quad f_{31} \quad \dots \quad f_{33}]^\top \in \mathbb{R}^9 \quad \text{column vector from matrix}$$

$$\mathbf{D} = \begin{bmatrix} (\text{vec}(\underline{\mathbf{y}}_1 \underline{\mathbf{x}}_1^\top))^\top \\ (\text{vec}(\underline{\mathbf{y}}_2 \underline{\mathbf{x}}_2^\top))^\top \\ (\text{vec}(\underline{\mathbf{y}}_3 \underline{\mathbf{x}}_3^\top))^\top \\ \vdots \\ (\text{vec}(\underline{\mathbf{y}}_k \underline{\mathbf{x}}_k^\top))^\top \end{bmatrix} = \begin{bmatrix} u_1^1 u_1^2 & u_1^1 v_1^2 & u_1^1 & u_1^2 v_1^1 & v_1^1 v_1^2 & v_1^1 & u_1^2 & v_1^2 & 1 \\ u_2^1 u_2^2 & u_2^1 v_2^2 & u_2^1 & u_2^2 v_2^1 & v_2^1 v_2^2 & v_2^1 & u_2^2 & v_2^2 & 1 \\ u_3^1 u_3^2 & u_3^1 v_3^2 & u_3^1 & u_3^2 v_3^1 & v_3^1 v_3^2 & v_3^1 & u_3^2 & v_3^2 & 1 \\ \vdots & \vdots & \vdots & \vdots & \vdots & \vdots & \vdots & \vdots & \vdots \\ u_k^1 u_k^2 & u_k^1 v_k^2 & u_k^1 & u_k^2 v_k^1 & v_k^1 v_k^2 & v_k^1 & u_k^2 & v_k^2 & 1 \end{bmatrix} \in \mathbb{R}^{k,9}$$

$$\mathbf{D} \text{vec}(\mathbf{F}) = \mathbf{0}$$

## ►7-Point Algorithm Continued

$$\mathbf{D} \operatorname{vec}(\mathbf{F}) = \mathbf{0}, \quad \mathbf{D} \in \mathbb{R}^{k,9}$$

- for  $k = 7$  we have a rank-deficient system, the null-space of  $\mathbf{D}$  is 2-dimensional
- but we know that  $\det \mathbf{F} = 0$ , hence
  1. find a basis of the null space of  $\mathbf{D}$ :  $\mathbf{F}_1, \mathbf{F}_2$
  2. get up to 3 real solutions for  $\alpha$  from

by SVD or QR factorization

$$\det(\alpha \mathbf{F}_1 + (1 - \alpha) \mathbf{F}_2) = 0 \quad \text{cubic equation in } \alpha$$

3. get up to 3 fundamental matrices  $\mathbf{F}_i = \alpha_i \mathbf{F}_1 + (1 - \alpha_i) \mathbf{F}_2$
  4. if  $\operatorname{rank} \mathbf{F}_i < 2$  for all  $i = 1, 2, 3$  then fail
- the result may depend on image (domain) transformations
  - normalization improves conditioning
  - this gives a good starting point for the full algorithm
  - dealing with mismatches need not be a part of the 7-point algorithm

→92

→111

→114

## ► Degenerate Configurations for Fundamental Matrix Estimation

When is  $\mathbf{F}$  not uniquely determined from any number of correspondences?

[H&Z, Sec. 11.9]

### 1. when images are related by homography

- a) camera centers coincide  $\mathbf{t}_{21} = 0$ :  $\mathbf{H} = \mathbf{K}_2 \mathbf{R}_{21} \mathbf{K}_1^{-1}$   $\mathbf{H}$  – as in epipolar homography
- b) camera moves but all 3D points lie in a plane  $(\mathbf{n}, d)$ :  $\mathbf{H} = \mathbf{K}_2 (\mathbf{R}_{21} - \mathbf{t}_{21} \mathbf{n}^\top / d) \mathbf{K}_1^{-1}$

- in either case: epipolar geometry is not defined
- we get an arbitrary solution from the 7-point algorithm, in the form of  $\mathbf{F} = [\underline{\mathbf{s}}]_{\times} \mathbf{H}$

note that  $[\underline{\mathbf{s}}]_{\times} \mathbf{H} \simeq \mathbf{H}' [\underline{\mathbf{s}}']_{\times} \rightarrow 76$

- given (arbitrary, fixed) point  $\underline{\mathbf{s}}$
- and correspondence  $x_i \leftrightarrow y_i$
- $y_i$  is the image of  $x_i$ :  $\underline{\mathbf{y}}_i \simeq \mathbf{H} \underline{\mathbf{x}}_i$
- a necessary condition:  $y_i \in l_i$ ,  $l_i \simeq \underline{\mathbf{s}} \times \mathbf{H} \underline{\mathbf{x}}_i$

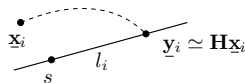

$$0 = \underline{\mathbf{y}}_i^\top (\underline{\mathbf{s}} \times \mathbf{H} \underline{\mathbf{x}}_i) = \underline{\mathbf{y}}_i^\top [\underline{\mathbf{s}}]_{\times} \mathbf{H} \underline{\mathbf{x}}_i \quad \text{for any } \underline{\mathbf{x}}_i, \underline{\mathbf{y}}_i, \underline{\mathbf{s}} (!)$$

### 2. both camera centers and all 3D points lie on a ruled quadric

hyperboloid of one sheet, cones, cylinders, two planes

- there are 3 solutions for  $\mathbf{F}$

### notes

- estimation of  $\mathbf{E}$  can deal with planes:  $[\underline{\mathbf{s}}]_{\times} \mathbf{H}$  is essential, then  $\mathbf{H} = \mathbf{R} - \mathbf{t} \mathbf{n}^\top / d$ , and  $\underline{\mathbf{s}} \simeq \mathbf{t}$  not arbitrary
- a complete treatment with additional degenerate configurations in [H&Z, sec. 22.2]
- a stronger epipolar constraint could reject some configurations (see next)



# A Note on Oriented Epipolar Constraint

- a tighter epipolar constraint that preserves orientations
- requires all points and cameras be on the same side of the plane at infinity

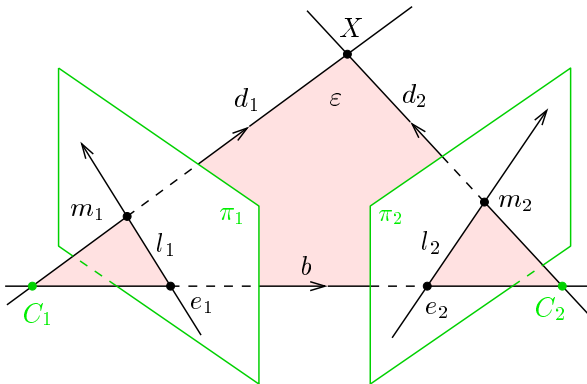

$$(\mathbf{e}_2 \times \underline{\mathbf{m}}_2) \underset{\sim}{\perp} \mathbf{F} \underline{\mathbf{m}}_1$$

notation:  $\underline{\mathbf{m}} \underset{\sim}{\perp} \underline{\mathbf{n}}$  means  $\underline{\mathbf{m}} = \lambda \underline{\mathbf{n}}$ ,  $\lambda > 0$

- we can read the constraint as  $(\mathbf{e}_2 \times \underline{\mathbf{m}}_2) \underset{\sim}{\perp} \mathbf{H}_e^{-T} (\mathbf{e}_1 \times \underline{\mathbf{m}}_1)$
- note that the constraint is not invariant to the change of either sign of  $\underline{\mathbf{m}}_i$
- all 7 correspondences in 7-point alg. must have the same sign
- this may help reject some wrong matches, see →114
- an even more tight constraint: scene points in front of both cameras

see later

[Chum et al. 2004]

expensive

this is called chirality constraint

## ►5-Point Algorithm for Relative Camera Orientation

**Problem:** Given  $\{m_i, m'_i\}_{i=1}^5$  corresponding image points and calibration matrix  $\mathbf{K}$ , recover the camera motion  $\mathbf{R}$ ,  $\mathbf{t}$ .

**Obs:**

1.  $\mathbf{E}$  – homogeneous  $3 \times 3$  matrix; 9 numbers up to scale
2.  $\mathbf{R}$  – 3 DOF,  $\mathbf{t}$  – 2 DOF only, in total 5 DOF  $\rightarrow$  we need  $9 - 1 - 5 = 3$  constraints on  $\mathbf{E}$
3. idea:  $\mathbf{E}$  essential iff it has two equal singular values and the third is zero  $\rightarrow$ 81

**This gives an equation system:**

$$\underline{\mathbf{v}}_i^\top \mathbf{E} \underline{\mathbf{v}}'_i = 0 \quad 5 \text{ linear constraints } (\underline{\mathbf{v}} \simeq \mathbf{K}^{-1} \underline{\mathbf{m}})$$

$$\det \mathbf{E} = 0 \quad 1 \text{ cubic constraint}$$

$$\mathbf{E} \mathbf{E}^\top \mathbf{E} - \frac{1}{2} \text{tr}(\mathbf{E} \mathbf{E}^\top) \mathbf{E} = 0 \quad 9 \text{ cubic constraints, 2 independent}$$

⊗ P1; 1pt: verify the last equation from  $\mathbf{E} = \mathbf{U} \mathbf{D} \mathbf{V}^\top$ ,  $\mathbf{D} = \lambda \text{diag}(1, 1, 0)$

1. estimate  $\mathbf{E}$  by SVD from  $\underline{\mathbf{v}}_i^\top \mathbf{E} \underline{\mathbf{v}}'_i = 0$  by the null-space method 4D null space
2. this gives  $\mathbf{E} \simeq x \mathbf{E}_1 + y \mathbf{E}_2 + z \mathbf{E}_3 + \mathbf{E}_4$
3. at most 10 (complex) solutions for  $x, y, z$  from the cubic constraints

- when all 3D points lie on a plane: at most 2 real solutions (twisted-pair) can be disambiguated in 3 views  
or by chirality constraint ( $\rightarrow$ 83) unless all 3D points are closer to one camera
- 6-point problem for unknown  $f$  [Kukelova et al. BMVC 2008]
- resources at <http://aag.ciirc.cvut.cz/minimal/>

## ► The Triangulation Problem

**Problem:** Given cameras  $\mathbf{P}_1, \mathbf{P}_2$  and a correspondence  $x \leftrightarrow y$  compute a 3D point  $\mathbf{X}$  projecting to  $x$  and  $y$

$$\lambda_1 \underline{\mathbf{x}} = \mathbf{P}_1 \underline{\mathbf{X}}, \quad \lambda_2 \underline{\mathbf{y}} = \mathbf{P}_2 \underline{\mathbf{X}}, \quad \underline{\mathbf{x}} = \begin{bmatrix} u^1 \\ v^1 \\ 1 \end{bmatrix}, \quad \underline{\mathbf{y}} = \begin{bmatrix} u^2 \\ v^2 \\ 1 \end{bmatrix}, \quad \mathbf{P}_i = \begin{bmatrix} (\mathbf{p}_1^i)^\top \\ (\mathbf{p}_2^i)^\top \\ (\mathbf{p}_3^i)^\top \end{bmatrix}$$

**Linear triangulation method** after eliminating  $\lambda_1, \lambda_2$

$$\begin{aligned} u^1 (\mathbf{p}_3^1)^\top \underline{\mathbf{X}} &= (\mathbf{p}_1^1)^\top \underline{\mathbf{X}}, & u^2 (\mathbf{p}_3^2)^\top \underline{\mathbf{X}} &= (\mathbf{p}_1^2)^\top \underline{\mathbf{X}}, \\ v^1 (\mathbf{p}_3^1)^\top \underline{\mathbf{X}} &= (\mathbf{p}_2^1)^\top \underline{\mathbf{X}}, & v^2 (\mathbf{p}_3^2)^\top \underline{\mathbf{X}} &= (\mathbf{p}_2^2)^\top \underline{\mathbf{X}} \end{aligned}$$

Gives

$$\mathbf{D} \underline{\mathbf{X}} = \mathbf{0}, \quad \mathbf{D} = \begin{bmatrix} u^1 (\mathbf{p}_3^1)^\top - (\mathbf{p}_1^1)^\top \\ v^1 (\mathbf{p}_3^1)^\top - (\mathbf{p}_2^1)^\top \\ u^2 (\mathbf{p}_3^2)^\top - (\mathbf{p}_1^2)^\top \\ v^2 (\mathbf{p}_3^2)^\top - (\mathbf{p}_2^2)^\top \end{bmatrix}, \quad \mathbf{D} \in \mathbb{R}^{4,4}, \quad \underline{\mathbf{X}} \in \mathbb{R}^4 \quad (14)$$

- typically,  $\mathbf{D}$  has full rank (!)
- what else: back-projected rays will generally not intersect due to image error, see next
- what else: using Jack-knife ( $\rightarrow 63$ ) not recommended
- idea: we will step back and use SVD ( $\rightarrow 90$ )
- but the result will not be invariant to projective frame

sensitive to small error

replacing  $\mathbf{P}_1 \mapsto \mathbf{P}_1 \mathbf{H}, \mathbf{P}_2 \mapsto \mathbf{P}_2 \mathbf{H}$  does not always result in  $\underline{\mathbf{X}} \mapsto \mathbf{H}^{-1} \underline{\mathbf{X}}$

- note the homogeneous form in (14) can represent points  $\underline{\mathbf{X}}$  at infinity

## ► The Least-Squares Triangulation by SVD

- if  $\mathbf{D}$  is full-rank we may minimize the algebraic least-squares error

$$\epsilon^2(\underline{\mathbf{X}}) = \|\mathbf{D}\underline{\mathbf{X}}\|^2 \quad \text{s.t.} \quad \|\underline{\mathbf{X}}\| = 1, \quad \underline{\mathbf{X}} \in \mathbb{R}^4$$

- let  $\mathbf{d}_i$  be the  $i$ -th row of  $\mathbf{D}$  taken as a column vector, then

$$\|\mathbf{D}\underline{\mathbf{X}}\|^2 = \sum_{i=1}^4 (\mathbf{d}_i^\top \underline{\mathbf{X}})^2 = \sum_{i=1}^4 \underline{\mathbf{X}}^\top \mathbf{d}_i \mathbf{d}_i^\top \underline{\mathbf{X}} = \underline{\mathbf{X}}^\top \mathbf{Q} \underline{\mathbf{X}}, \quad \text{where } \mathbf{Q} = \sum_{i=1}^4 \mathbf{d}_i \mathbf{d}_i^\top = \mathbf{D}^\top \mathbf{D} \in \mathbb{R}^{4,4}$$

- we write the SVD of  $\mathbf{Q}$  as  $\mathbf{Q} = \sum_{j=1}^4 \sigma_j^2 \mathbf{u}_j \mathbf{u}_j^\top$ , in which

[Golub & van Loan 2013, Sec. 2.5]

$$\sigma_1^2 \geq \dots \geq \sigma_4^2 \geq 0 \quad \text{and} \quad \mathbf{u}_l^\top \mathbf{u}_m = \begin{cases} 0 & \text{if } l \neq m \\ 1 & \text{otherwise} \end{cases}$$

- then  $\min_{\mathbf{q}, \|\mathbf{q}\|=1} \mathbf{q}^\top \mathbf{Q} \mathbf{q} = \sigma_4^2$  and  $\underline{\mathbf{X}} = \arg \min_{\mathbf{q}, \|\mathbf{q}\|=1} \mathbf{q}^\top \mathbf{Q} \mathbf{q} = \mathbf{u}_4$   $\mathbf{u}_4$  – the last column of  $\mathbf{U}$  from SVD( $\mathbf{Q}$ )

**Proof (by contradiction).**

Let  $\bar{\mathbf{q}} = \sum_{i=1}^4 a_i \mathbf{u}_i$  s.t.  $\sum_{i=1}^4 a_i^2 = 1$ , then  $\|\bar{\mathbf{q}}\| = 1$ , as desired, and

$$\bar{\mathbf{q}}^\top \mathbf{Q} \bar{\mathbf{q}} = \sum_{j=1}^4 \sigma_j^2 \bar{\mathbf{q}}^\top \mathbf{u}_j \mathbf{u}_j^\top \bar{\mathbf{q}} = \sum_{j=1}^4 \sigma_j^2 (\mathbf{u}_j^\top \bar{\mathbf{q}})^2 = \dots = \sum_{j=1}^4 a_j^2 \sigma_j^2 \geq \sum_{j=1}^4 a_j^2 \sigma_4^2 = \left( \sum_{j=1}^4 a_j^2 \right) \sigma_4^2 = \sigma_4^2$$

since  $\sigma_j \geq \sigma_4$

□

- if  $\sigma_4 \ll \sigma_3$ , there is a unique solution  $\underline{\mathbf{X}} = \mathbf{u}_4$  with residual error  $(\mathbf{D} \underline{\mathbf{X}})^2 = \sigma_4^2$   
the quality (conditioning) of the solution may be expressed as  $q = \sigma_3/\sigma_4$  (greater is better)

Matlab code for the least-squares solver:

```
[U,0,V] = svd(D);  
X = V(:,end);  
q = sqrt(0(end-1,end-1)/0(end,end));
```

⊛ P1; 1pt: Why did we decompose  $\mathbf{D}$  here, and not  $\mathbf{Q} = \mathbf{D}^\top \mathbf{D}$ ?

## ► Numerical Conditioning

- The equation  $\mathbf{D}\underline{\mathbf{X}} = \mathbf{0}$  in (14) may be ill-conditioned for numerical computation, which results in a poor estimate for  $\underline{\mathbf{X}}$ .

**Why:** on a row of  $\mathbf{D}$  there are big entries together with small entries, e.g. of orders projection centers in mm, image points in px

$$\begin{bmatrix} 10^3 & 0 & 10^3 & 10^6 \\ 0 & 10^3 & 10^3 & 10^6 \\ 10^3 & 0 & 10^3 & 10^6 \\ 0 & 10^3 & 10^3 & 10^6 \end{bmatrix}$$

### Quick fix:

1. re-scale the problem by a regular diagonal conditioning matrix  $\mathbf{S} \in \mathbb{R}^{4,4}$

$$\mathbf{0} = \mathbf{D}\underline{\mathbf{X}} = \mathbf{D}\mathbf{S}\mathbf{S}^{-1}\underline{\mathbf{X}} = \bar{\mathbf{D}}\bar{\underline{\mathbf{X}}}$$

choose  $\mathbf{S}$  to make the entries in  $\hat{\mathbf{D}}$  all smaller than unity in absolute value:

$$\mathbf{S} = \text{diag}(10^{-3}, 10^{-3}, 10^{-3}, 10^{-6}) \quad \mathbf{S} = \text{diag}(1./\max(\text{abs}(\mathbf{D}), [], 1))$$

2. solve for  $\bar{\underline{\mathbf{X}}}$  as before
3. get the final solution as  $\underline{\mathbf{X}} = \mathbf{S}\bar{\underline{\mathbf{X}}}$

- when SVD is used in camera resection, conditioning is essential for success

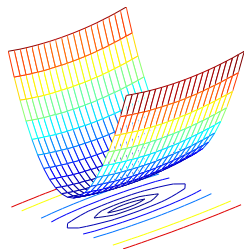

# Algebraic Error vs Reprojection Error

- algebraic error ( $c$  – camera index,  $(u^c, v^c)$  – image coordinates)

from SVD  $\rightarrow 91$

$$\varepsilon^2(\underline{\mathbf{X}}) = \sigma_4^2 = \sum_{c=1}^2 \left[ \left( u^c (\mathbf{p}_3^c)^\top \underline{\mathbf{X}} - (\mathbf{p}_1^c)^\top \underline{\mathbf{X}} \right)^2 + \left( v^c (\mathbf{p}_3^c)^\top \underline{\mathbf{X}} - (\mathbf{p}_2^c)^\top \underline{\mathbf{X}} \right)^2 \right]$$

- reprojection error

$$e^2(\underline{\mathbf{X}}) = \sum_{c=1}^2 \left[ \left( u^c - \frac{(\mathbf{p}_1^c)^\top \underline{\mathbf{X}}}{(\mathbf{p}_3^c)^\top \underline{\mathbf{X}}} \right)^2 + \left( v^c - \frac{(\mathbf{p}_2^c)^\top \underline{\mathbf{X}}}{(\mathbf{p}_3^c)^\top \underline{\mathbf{X}}} \right)^2 \right]$$

- algebraic error zero  $\Leftrightarrow$  reprojection error zero
- epipolar constraint satisfied  $\Rightarrow$  equivalent results
- in general: minimizing algebraic error is cheap but it gives inferior results
- minimizing reprojection error is expensive but it gives good results
- the midpoint of the common perpendicular to both optical rays gives about 50% greater error in 3D
- the golden standard method – deferred to  $\rightarrow 106$

$\sigma_4 = 0 \Rightarrow$  non-trivial null space

Ex:

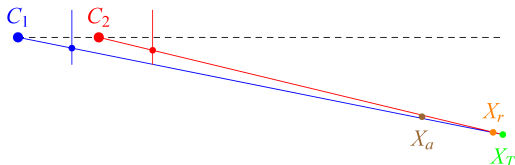

- forward camera motion
- error  $f/50$  in image 2, orthogonal to epipolar plane

$X_T$  – noiseless ground truth position  
 $X_r$  – reprojection error minimizer  
 $X_a$  – algebraic error minimizer  
 $m$  – measurement ( $m_T$  with noise in  $v^2$ )

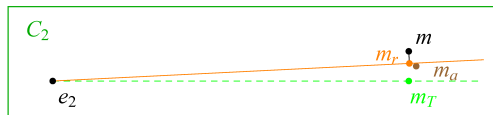
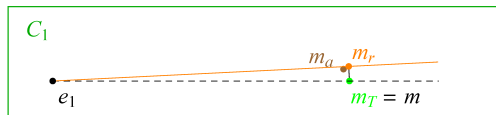

## ► We Have Added to The ZOO (cont'd from →69)

problem	given	unknown	slide
camera resection	6 world–img correspondences $\{(X_i, m_i)\}_{i=1}^6$	<b>P</b>	62
exterior orientation	<b>K</b> , 3 world–img correspondences $\{(X_i, m_i)\}_{i=1}^3$	<b>R, t</b>	66
relative pointcloud orientation	3 world–world correspondences $\{(X_i, Y_i)\}_{i=1}^3$	<b>R, t</b>	70
fundamental matrix	7 img–img correspondences $\{(m_i, m'_i)\}_{i=1}^7$	<b>F</b>	84
relative camera orientation	<b>K</b> , 5 img–img correspondences $\{(m_i, m'_i)\}_{i=1}^5$	<b>R, t</b>	88
triangulation	<b>P</b> <sub>1</sub> , <b>P</b> <sub>2</sub> , 1 img–img correspondence $(m_i, m'_i)$	<b>X</b>	89

A bigger ZOO at <http://aag.ciirc.cvut.cz/minimal/>

### calibrated problems

- have fewer degenerate configurations
- can do with fewer points (good for geometry proposal generators →121)
- algebraic error optimization (SVD) makes sense in camera resection and triangulation only
- but it is not the best method; we will now focus on 'optimizing optimally'





## Optimization for 3D Vision

- 5.1 The Concept of Error for Epipolar Geometry
- 5.2 The Golden Standard for Triangulation
- 5.3 Levenberg-Marquardt's Iterative Optimization
- 5.4 Optimizing Fundamental Matrix
- 5.5 The Correspondence Problem
- 5.6 Optimization by Random Sampling

### covered by

- [1] [H&Z] Secs: 11.4, 11.6, 4.7
- [2] Fischler, M.A. and Bolles, R.C. . Random Sample Consensus: A Paradigm for Model Fitting with Applications to Image Analysis and Automated Cartography. *Communications of the ACM* 24(6):381–395, 1981

### additional references

-  P. D. Sampson. Fitting conic sections to 'very scattered' data: An iterative refinement of the Bookstein algorithm. *Computer Vision, Graphics, and Image Processing*, 18:97–108, 1982.
-  O. Chum, J. Matas, and J. Kittler. Locally optimized RANSAC. In *Proc DAGM, LNCS 2781:236–243*. Springer-Verlag, 2003.
-  O. Chum, T. Werner, and J. Matas. Epipolar geometry estimation via RANSAC benefits from the oriented epipolar constraint. In *Proc ICPR*, vol 1:112–115, 2004.

## ► The Concept of Error for Epipolar Geometry

**Background problems:** (1) Given at least 8 matched points  $x_i \leftrightarrow y_j$  in a general position, estimate the most 'likely' fundamental matrix  $\mathbf{F}$ ; (2) given  $\mathbf{F}$  triangulate 3D point from  $x_i \leftrightarrow y_j$ .

$$\mathbf{x}_i = (u_i^1, v_i^1), \quad \mathbf{y}_i = (u_i^2, v_i^2), \quad i = 1, 2, \dots, k, \quad k \geq 8$$

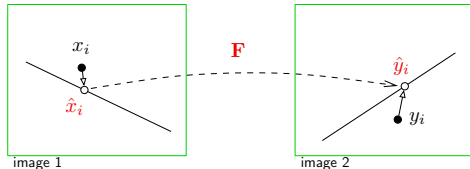

- detected points (measurements)  $x_i, y_i$
- we introduce matches  $\mathbf{Z}_i = (\mathbf{x}_i, \mathbf{y}_i) = (u_i^1, v_i^1, u_i^2, v_i^2) \in \mathbb{R}^4$ ; and the set  $Z = \{\mathbf{Z}_i\}_{i=1}^k$
- corrected points  $\hat{x}_i, \hat{y}_i$ ;  $\hat{\mathbf{Z}}_i = (\hat{x}_i, \hat{y}_i) = (\hat{u}_i^1, \hat{v}_i^1, \hat{u}_i^2, \hat{v}_i^2)$ ;  $\hat{Z} = \{\hat{\mathbf{Z}}_i\}_{i=1}^k$  are correspondences
- correspondences satisfy the epipolar geometry exactly  $\hat{\mathbf{y}}_i^\top \mathbf{F} \hat{\mathbf{x}}_i = 0, i = 1, \dots, k$
- small correction is more probable
- let  $\mathbf{e}_i(\cdot)$  be the 'reprojection error' (vector) per match  $i$ ,

$$\mathbf{e}_i(x_i, y_i \mid \hat{x}_i, \hat{y}_i, \mathbf{F}) = \begin{bmatrix} \mathbf{x}_i - \hat{\mathbf{x}}_i \\ \mathbf{y}_i - \hat{\mathbf{y}}_i \end{bmatrix} = \mathbf{e}_i(\mathbf{Z}_i \mid \hat{\mathbf{Z}}_i, \mathbf{F}) = \mathbf{Z}_i - \hat{\mathbf{Z}}_i(\mathbf{F}) \quad (15)$$

$$\|\mathbf{e}_i(\cdot)\|^2 \stackrel{\text{def}}{=} \mathbf{e}_i^2(\cdot) = \|\mathbf{x}_i - \hat{\mathbf{x}}_i\|^2 + \|\mathbf{y}_i - \hat{\mathbf{y}}_i\|^2 = \|\mathbf{Z}_i - \hat{\mathbf{Z}}_i(\mathbf{F})\|^2$$

- the total reprojection error (of all data) then is

$$L(Z | \hat{\mathbf{Z}}, \mathbf{F}) = \sum_{i=1}^k \mathbf{e}_i^2(x_i, y_i | \hat{\mathbf{x}}_i, \hat{\mathbf{y}}_i, \mathbf{F}) = \sum_{i=1}^k \mathbf{e}_i^2(\mathbf{Z}_i | \hat{\mathbf{Z}}_i, \mathbf{F})$$

- and the optimization problem is

$$(\hat{\mathbf{Z}}^*, \mathbf{F}^*) = \arg \min_{\mathbf{F}, \hat{\mathbf{Z}}} L(Z | \hat{\mathbf{Z}}, \mathbf{F}) \quad \text{s.t.} \quad \text{rank } \mathbf{F} = 2, \hat{\mathbf{y}}_i^\top \mathbf{F} \hat{\mathbf{x}}_i = 0, (\hat{\mathbf{x}}_i, \hat{\mathbf{y}}_i) \in \hat{\mathbf{Z}}_i \quad (16)$$

### Three possible approaches

- they differ in how the correspondences  $\hat{\mathbf{x}}_i, \hat{\mathbf{y}}_i$  are obtained:
  - direct optimization of reprojection error over all variables  $\hat{\mathbf{Z}}, \mathbf{F}$  →98
  - Sampson optimal correction = partial correction of  $\mathbf{Z}_i$  towards  $\hat{\mathbf{Z}}_i$  used in an iterative minimization over  $\mathbf{F}$  →100
  - removing  $\hat{\mathbf{x}}_i, \hat{\mathbf{y}}_i$  altogether = marginalization of  $L(Z, \hat{\mathbf{Z}} | \mathbf{F})$  over  $\hat{\mathbf{Z}}$  followed by minimization over  $\mathbf{F}$   
not covered, the marginalization is difficult

## Method 1: Reprojection Error Optimization: Idea

- we need to encode the constraints  $\hat{\mathbf{y}}_i^T \mathbf{F} \hat{\mathbf{x}}_i = 0$ ,  $\text{rank } \mathbf{F} = 2$
- idea: reconstruct 3D point via equivalent projection matrices and use reprojection error
- the equivalent projection matrices are see [H&Z, Sec. 9.5] for complete characterization

$$\mathbf{P}_1 = [\mathbf{I} \quad \mathbf{0}], \quad \mathbf{P}_2 = [[\mathbf{e}_2]_{\times} \mathbf{F} + \mathbf{e}_2 \mathbf{e}_1^T \quad \mathbf{e}_2] \quad (17)$$

⊗ H3; 2pt: Given rank-2 matrix  $\mathbf{F}$ , let  $\mathbf{e}_1, \mathbf{e}_2$  be the right and left nullspace basis vectors of  $\mathbf{F}$ , respectively. Verify that such  $\mathbf{F}$  is a fundamental matrix of  $\mathbf{P}_1, \mathbf{P}_2$  from (17).

Hints:

- (1) consider  $\hat{\mathbf{x}}_i = \mathbf{P}_1 \mathbf{X}_i$  and  $\hat{\mathbf{y}}_i = \mathbf{P}_2 \mathbf{X}_i$
- (2)  $\mathbf{A}$  is skew symmetric iff  $\mathbf{x}^T \mathbf{A} \mathbf{x} = 0$  for all vectors  $\mathbf{x}$ .

## (cont'd) Reprojection Error Optimization: Algorithm

1. compute  $\mathbf{F}^{(0)}$  by the 7-point algorithm  $\rightarrow 84$ ; construct camera  $\mathbf{P}_2^{(0)}$  from  $\mathbf{F}^{(0)}$  using (17)
2. triangulate 3D points  $\hat{\mathbf{X}}_i^{(0)}$  from matches  $(x_i, y_i)$  for all  $i = 1, \dots, k$   $\rightarrow 89$
3. starting from  $\mathbf{P}_2^{(0)}$ ,  $\hat{\mathbf{X}}_{1:k}^{(0)}$  minimize the reprojection error (15)

$$(\hat{\mathbf{X}}_{1:k}^*, \mathbf{F}^*) = \arg \min_{\mathbf{F}, \hat{\mathbf{X}}_{1:k}} \sum_{i=1}^k e_i^2(\mathbf{Z}_i \mid \hat{\mathbf{Z}}_i(\hat{\mathbf{X}}_i, \mathbf{P}_2(\mathbf{F})))$$

where

$$\hat{\mathbf{Z}}_i = (\hat{\mathbf{x}}_i, \hat{\mathbf{y}}_i) \text{ (Cartesian)}, \quad \hat{\mathbf{x}}_i \simeq \mathbf{P}_1 \hat{\mathbf{X}}_i, \quad \hat{\mathbf{y}}_i \simeq \mathbf{P}_2(\mathbf{F}) \hat{\mathbf{X}}_i \text{ (homogeneous)}$$

- non-linear, non-convex problem
- solves  $\mathbf{F}$  estimation and triangulation of all  $k$  points jointly
- the solver would be quite slow
- $3k + 7$  parameters to be found: latent:  $\hat{\mathbf{X}}_i$ , for all  $i$  (correspondences!), non-latent:  $\mathbf{F}$
- we need minimal representations for  $\hat{\mathbf{X}}_i$  and  $\mathbf{F}$   $\rightarrow 151$  or introduce constraints
- there are other pitfalls; this is essentially bundle adjustment; we will return to this later  $\rightarrow 139$

## ► Method 2: First-Order Error Approximation

An elegant method for solving problems like (16):

- we will get rid of the latent parameters  $\hat{X}$  needed for obtaining the correction

[H&Z, p. 287], [Sampson 1982]

- we will recycle the algebraic error  $\epsilon = \mathbf{y}^\top \mathbf{F} \mathbf{x}$  from  $\rightarrow 84$

- consider matches  $\mathbf{Z}_i$ , correspondences  $\hat{\mathbf{Z}}_i$ , and reprojection error  $\mathbf{e}_i = \|\mathbf{Z}_i - \hat{\mathbf{Z}}_i\|^2$

- correspondences satisfy  $\hat{\mathbf{y}}_i^\top \mathbf{F} \hat{\mathbf{x}}_i = 0$ ,

$$\hat{\mathbf{x}}_i = (\hat{u}^1, \hat{v}^1, 1), \quad \hat{\mathbf{y}}_i = (\hat{u}^2, \hat{v}^2, 1)$$

- this is a manifold  $\mathcal{V}_F \in \mathbb{R}^4$ : a set of points  $\hat{\mathbf{Z}} = (\hat{u}^1, \hat{v}^1, \hat{u}^2, \hat{v}^2)$  consistent with  $\mathbf{F}$

- algebraic error vanishes for  $\hat{\mathbf{Z}}_i$ :  $\mathbf{0} = \epsilon_i(\hat{\mathbf{Z}}_i) = \hat{\mathbf{y}}_i^\top \mathbf{F} \hat{\mathbf{x}}_i$

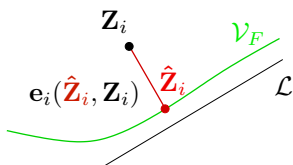

**Sampson's idea:** Linearize the algebraic error  $\epsilon(\mathbf{Z})$  at  $\mathbf{Z}_i$  (where it is non-zero) and evaluate the resulting linear function at  $\hat{\mathbf{Z}}_i$  (where it is zero). The zero-crossing replaces  $\mathcal{V}_F$  by a linear manifold  $\mathcal{L}$ . The point on  $\mathcal{V}_F$  closest to  $\mathbf{Z}_i$  is replaced by the closest point on  $\mathcal{L}$ .

$$0 = \epsilon_i(\hat{\mathbf{Z}}_i) \approx \epsilon_i(\mathbf{Z}_i) + \frac{\partial \epsilon_i(\mathbf{Z}_i)}{\partial \mathbf{Z}_i} (\hat{\mathbf{Z}}_i - \mathbf{Z}_i)$$

## ►Sampson's Approximation of Reprojection Error

- linearize  $\varepsilon(\mathbf{Z})$  at match  $\mathbf{Z}_i$ , evaluate it at correspondence  $\hat{\mathbf{Z}}_i$

$$\varepsilon_i(\mathbf{Z}_i) + \underbrace{\frac{\partial \varepsilon_i(\mathbf{Z}_i)}{\partial \mathbf{Z}_i}}_{\mathbf{J}_i(\mathbf{Z}_i)} \underbrace{(\hat{\mathbf{Z}}_i - \mathbf{Z}_i)}_{\mathbf{e}_i(\hat{\mathbf{Z}}_i, \mathbf{Z}_i)} \stackrel{\text{def}}{=} \underbrace{\varepsilon_i(\mathbf{Z}_i)}_{\text{given}} + \mathbf{J}_i(\mathbf{Z}_i) \underbrace{\mathbf{e}_i(\hat{\mathbf{Z}}_i, \mathbf{Z}_i)}_{\text{wanted}} = \varepsilon_i(\hat{\mathbf{Z}}_i) \stackrel{!}{=} 0$$

- goal: compute function  $\mathbf{e}_i(\cdot)$  from  $\varepsilon_i(\cdot)$ , where  $\mathbf{e}_i(\cdot)$  is the distance of  $\hat{\mathbf{Z}}_i$  from  $\mathbf{Z}_i$
- we have a linear underconstrained equation for  $\mathbf{e}_i(\cdot)$
- we look for a minimal  $\mathbf{e}_i(\cdot)$  per match  $i$

e.g.  $\varepsilon_i \in \mathbb{R}$ ,  $\mathbf{e}_i \in \mathbb{R}^4$

$$\mathbf{e}_i(\cdot)^* = \arg \min_{\mathbf{e}_i(\cdot)} \|\mathbf{e}_i(\cdot)\|^2 \quad \text{subject to} \quad \varepsilon_i(\cdot) + \mathbf{J}_i(\cdot) \mathbf{e}_i(\cdot) = 0$$

- which has a closed-form solution **note that  $\mathbf{J}_i(\cdot)$  is not invertible!**

⊛ P1; 1pt: derive  $\mathbf{e}_i^*(\cdot)$

$$\begin{aligned} \mathbf{e}_i^*(\cdot) &= -\mathbf{J}_i^\top (\mathbf{J}_i \mathbf{J}_i^\top)^{-1} \varepsilon_i(\cdot) && \text{pseudo-inverse} \\ \|\mathbf{e}_i^*(\cdot)\|^2 &= \varepsilon_i^\top(\cdot) (\mathbf{J}_i \mathbf{J}_i^\top)^{-1} \varepsilon_i(\cdot) \end{aligned} \tag{18}$$

- this maps  $\varepsilon_i(\cdot)$  to an estimate of  $\mathbf{e}_i(\cdot)$  per correspondence

- we often do not need  $\mathbf{e}_i$ , just  $\|\mathbf{e}_i\|^2$

exception: triangulation →106

- the unknown parameters  $\mathbf{F}$  are inside:  $\mathbf{e}_i = \mathbf{e}_i(\mathbf{F})$ ,  $\varepsilon_i = \varepsilon_i(\mathbf{F})$ ,  $\mathbf{J}_i = \mathbf{J}_i(\mathbf{F})$

## ► Example: Fitting A Circle To Scattered Points

**Problem:** Fit an origin-centered circle  $\mathcal{C}: \|\mathbf{x}\|^2 - r^2 = 0$  to a set of 2D points  $Z = \{\mathbf{x}_i\}_{i=1}^k$

1. consider radial error as the 'algebraic error'  $\varepsilon(\mathbf{x}) = \|\mathbf{x}\|^2 - r^2$  'arbitrary' choice
2. linearize it at  $\hat{\mathbf{x}}$  we are dropping  $i$  in  $\varepsilon_i, \mathbf{e}_i$  etc for clarity

$$\varepsilon(\hat{\mathbf{x}}) \approx \varepsilon(\mathbf{x}) + \underbrace{\frac{\partial \varepsilon(\mathbf{x})}{\partial \mathbf{x}}}_{\mathbf{J}(\mathbf{x})=2\mathbf{x}^\top} \underbrace{(\hat{\mathbf{x}} - \mathbf{x})}_{\mathbf{e}(\hat{\mathbf{x}}, \mathbf{x})} = \dots = 2\mathbf{x}^\top \hat{\mathbf{x}} - (r^2 + \|\mathbf{x}\|^2) \stackrel{\text{def}}{=} \varepsilon_L(\hat{\mathbf{x}})$$

$\varepsilon_L(\hat{\mathbf{x}}) = 0$  is a line with normal  $\frac{\mathbf{x}}{\|\mathbf{x}\|}$  and intercept  $\frac{r^2 + \|\mathbf{x}\|^2}{2\|\mathbf{x}\|}$  not tangent to  $\mathcal{C}$ , outside!

3. using (18), express error approximation  $\mathbf{e}^*$  as

$$\|\mathbf{e}^*\|^2 = \varepsilon^\top (\mathbf{J}\mathbf{J}^\top)^{-1} \varepsilon = \frac{(\|\mathbf{x}\|^2 - r^2)^2}{4\|\mathbf{x}\|^2}$$

4. fit circle

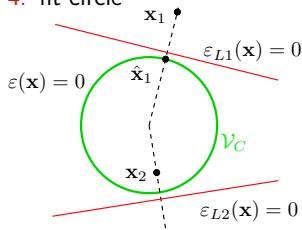

$$r^* = \arg \min_r \sum_{i=1}^k \frac{(\|\mathbf{x}_i\|^2 - r^2)^2}{4\|\mathbf{x}_i\|^2} = \dots = \left( \frac{1}{k} \sum_{i=1}^k \frac{1}{\|\mathbf{x}_i\|^2} \right)^{-\frac{1}{2}}$$

- this example results in a convex quadratic optimization problem
- note that the algebraic error minimizer is different:

$$\arg \min_r \sum_{i=1}^k (\|\mathbf{x}_i\|^2 - r^2)^2 = \left( \frac{1}{k} \sum_{i=1}^k \|\mathbf{x}_i\|^2 \right)^{\frac{1}{2}}$$



# Circle Fitting: Some Results

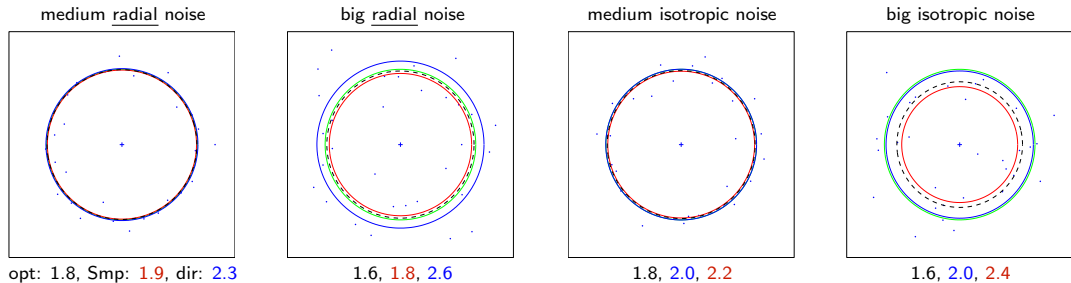

mean ranks over 10 000 random trials with  $k = 32$  samples; smaller is better

- solid green – ground truth
- solid red – Sampson error  $e$  minimizer
- solid blue – direct algebraic radial error  $\epsilon$  minimizer
- dashed black – optimal estimator for isotropic error

optimal estimator for isotropic error (black, dashed):

$$r \approx \frac{3}{4k} \sum_{i=1}^k \|\mathbf{x}_i\| + \sqrt{\left(\frac{3}{4k} \sum_{i=1}^k \|\mathbf{x}_i\|\right)^2 - \frac{1}{2k} \sum_{i=1}^k \|\mathbf{x}_i\|^2}$$

## which method is better?

- error should model noise, radial noise and isotropic noise behave differently
- ground truth: Normally distributed isotropic error, Gamma-distributed radial error
- Sampson: better for the radial distribution model; Direct: better for the isotropic model
- no matter how corrected, the algebraic error minimizer is not an unbiased parameter estimator

Cramér-Rao bound tells us how close one can get with unbiased estimator and given  $k$

# Discussion: On The Art of Probabilistic Model Design...

- a few probabilistic models for fitting zero-centered circle  $C$  of radius  $r$  to points in  $\mathbb{R}^2$

error model

marginalized over  $C$

orthogonal deviation from  $C$

Sampson approximation

radial p.d.f.

random sample

$p(\mathbf{x} | r)$

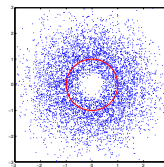
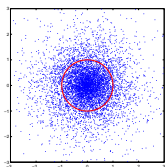
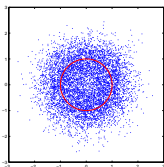
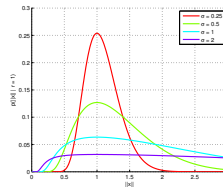
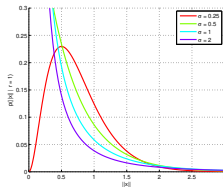
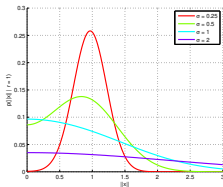
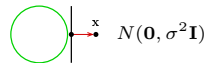
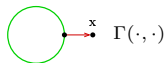
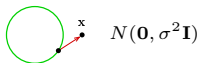

$$\approx \frac{1}{\sigma \sqrt{(2\pi)^3 r \|\mathbf{x}\|}} e^{-\frac{(\|\mathbf{x}\| - r)^2}{2\sigma^2}}$$

- mode inside the circle
- models the inside well
- tends to normal distribution

$$\frac{1}{2\pi \Gamma(\frac{r^2}{\sigma})} \frac{1}{\|\mathbf{x}\|^2} \left(\frac{r \|\mathbf{x}\|}{\sigma}\right)^{\frac{r^2}{\sigma}} e^{-\frac{r \|\mathbf{x}\|}{\sigma}}$$

- peak at the center
- unusable for small radii
- tends to Dirac distribution

$$\frac{1}{r\sigma \sqrt{(2\pi)^3}} e^{-\frac{e^2(\mathbf{x}; r)}{2\sigma^2}}$$

- mode at the circle
- hole at the center
- tends to normal distribution

## ► Sampson Error for Fundamental Matrix Manifold

The epipolar algebraic error is

assuming finite points

$$\varepsilon_i(\mathbf{F}) = \underline{\mathbf{y}}_i^\top \mathbf{F} \underline{\mathbf{x}}_i, \quad \underline{\mathbf{x}}_i = (u_i^1, v_i^1, 1), \quad \underline{\mathbf{y}}_i = (u_i^2, v_i^2, 1), \quad \varepsilon_i \in \mathbb{R}$$

Let  $\mathbf{F} = [\mathbf{F}_1 \quad \mathbf{F}_2 \quad \mathbf{F}_3]$  (per columns) =  $\begin{bmatrix} (\mathbf{F}^1)^\top \\ (\mathbf{F}^2)^\top \\ (\mathbf{F}^3)^\top \end{bmatrix}$  (per rows),  $\mathbf{S} = \begin{bmatrix} 1 & 0 & 0 \\ 0 & 1 & 0 \end{bmatrix}$ , then

### Sampson

$$\mathbf{J}_i(\mathbf{F}) = \left[ \frac{\partial \varepsilon_i(\mathbf{F})}{\partial u_i^1}, \frac{\partial \varepsilon_i(\mathbf{F})}{\partial v_i^1}, \frac{\partial \varepsilon_i(\mathbf{F})}{\partial u_i^2}, \frac{\partial \varepsilon_i(\mathbf{F})}{\partial v_i^2} \right] \quad \mathbf{J}_i \in \mathbb{R}^{1,4} \quad \text{derivatives over point coordinates}$$

$$= \left[ (\mathbf{F}_1)^\top \underline{\mathbf{y}}_i, (\mathbf{F}_2)^\top \underline{\mathbf{y}}_i, (\mathbf{F}^1)^\top \underline{\mathbf{x}}_i, (\mathbf{F}^2)^\top \underline{\mathbf{x}}_i \right] = \begin{bmatrix} \mathbf{S} \mathbf{F}^\top \underline{\mathbf{y}}_i \\ \mathbf{S} \mathbf{F} \underline{\mathbf{x}}_i \end{bmatrix}^\top$$

$$\mathbf{e}_i(\mathbf{F}) = -\frac{\mathbf{J}_i^\top(\mathbf{F}) \varepsilon_i(\mathbf{F})}{\|\mathbf{J}_i(\mathbf{F})\|^2} \quad \mathbf{e}_i(\mathbf{F}) \in \mathbb{R}^4 \quad \text{Sampson error vector}$$

$$e_i(\mathbf{F}) \stackrel{\text{def}}{=} \|\mathbf{e}_i(\mathbf{F})\| = \frac{\varepsilon_i(\mathbf{F})}{\|\mathbf{J}_i(\mathbf{F})\|} = \frac{\underline{\mathbf{y}}_i^\top \mathbf{F} \underline{\mathbf{x}}_i}{\sqrt{\|\mathbf{S} \mathbf{F} \underline{\mathbf{x}}_i\|^2 + \|\mathbf{S} \mathbf{F}^\top \underline{\mathbf{y}}_i\|^2}} \quad e_i(\mathbf{F}) \in \mathbb{R} \quad \text{scalar Sampson error}$$

- generalization for infinite points is easy
- Sampson error 'normalizes' the algebraic error
- automatically copes with multiplicative factors  $\mathbf{F} \mapsto \lambda \mathbf{F}$
- actual optimization not yet covered  $\rightarrow 110$

## ► Back to Triangulation: The Golden Standard Method

Given  $\mathbf{P}_1, \mathbf{P}_2$  and a correspondence  $x \leftrightarrow y$ , look for 3D point  $\mathbf{X}$  projecting to  $x$  and  $y$  →89

**Idea:**

1. if not given, compute  $\mathbf{F}$  from  $\mathbf{P}_1, \mathbf{P}_2$ , e.g.  $\mathbf{F} = (\mathbf{Q}_1 \mathbf{Q}_2^{-1})^\top [\mathbf{q}_1 - (\mathbf{Q}_1 \mathbf{Q}_2^{-1}) \mathbf{q}_2]_\times$  →77
2. correct the measurement by the linear estimate of the correction vector →101

$$\begin{bmatrix} \hat{u}^1 \\ \hat{v}^1 \\ \hat{u}^2 \\ \hat{v}^2 \end{bmatrix} \approx \begin{bmatrix} u^1 \\ v^1 \\ u^2 \\ v^2 \end{bmatrix} - \frac{\varepsilon}{\|\mathbf{J}\|^2} \mathbf{J}^\top = \begin{bmatrix} u^1 \\ v^1 \\ u^2 \\ v^2 \end{bmatrix} - \frac{\mathbf{y}^\top \mathbf{F} \mathbf{x}}{\|\mathbf{S} \mathbf{F} \mathbf{x}\|^2 + \|\mathbf{S} \mathbf{F}^\top \mathbf{y}\|^2} \begin{bmatrix} (\mathbf{F}_1)^\top \mathbf{y} \\ (\mathbf{F}_2)^\top \mathbf{y} \\ (\mathbf{F}^1)^\top \mathbf{x} \\ (\mathbf{F}^2)^\top \mathbf{x} \end{bmatrix}$$

3. use the SVD triangulation algorithm with numerical conditioning →90

**Ex (cont'd from →93):**

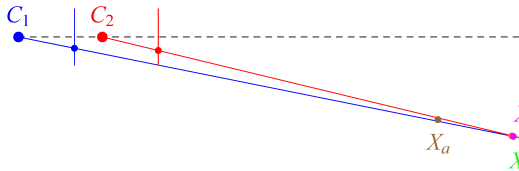

- $X_T$  – noiseless ground truth position
- – reprojection error minimizer
- $X_s$  – Sampson-corrected algebraic error minimizer
- $X_a$  – algebraic error minimizer
- $m$  – measurement ( $m_T$  with noise in  $v^2$ )

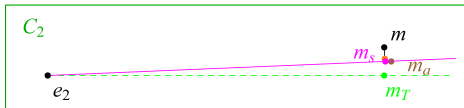
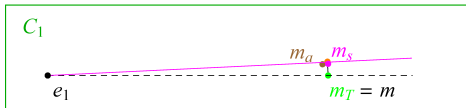

## ► Back to Fundamental Matrix Estimation

**Goal:** Given a set  $X = \{(x_i, y_i)\}_{i=1}^k$  of  $k \gg 7$  inlier correspondences, compute a statistically efficient estimate for fundamental matrix  $\mathbf{F}$ .

### What we have so far

- 7-point algorithm for  $\mathbf{F}$  (5-point algorithm for  $\mathbf{E}$ ) →84
- definition of Sampson error per correspondence  $e_i(\mathbf{F} | x_i, y_i)$  →105
- triangulation requiring an optimal  $\mathbf{F}$

### What we need

- correspondence recognition
- an optimization algorithm for many ( $k \gg 7$ ) correspondences

see later →114

comes next

$$\mathbf{F}^* = \arg \min_{\mathbf{F}} \sum_{i=1}^k e_i^2(\mathbf{F} | X)$$

- the 7-point estimate is a good starting point  $\mathbf{F}_0$

# Levenberg-Marquardt (LM) Iterative Optimization in a Nutshell

Consider error function  $\mathbf{e}_i(\boldsymbol{\theta}) = f(\mathbf{x}_i, \mathbf{y}_i, \boldsymbol{\theta}) \in \mathbb{R}^m$ , with  $\mathbf{x}_i, \mathbf{y}_i$  given,  $\boldsymbol{\theta} \in \mathbb{R}^q$  unknown

$\boldsymbol{\theta} = \mathbf{F}$ ,  $q = 9$ ,  $m = 1$  for f.m. estimation

**Our goal:**  $\boldsymbol{\theta}^* = \arg \min_{\boldsymbol{\theta}} \sum_{i=1}^k \|\mathbf{e}_i(\boldsymbol{\theta})\|^2$

**Idea 1** (Gauss-Newton approximation): proceed iteratively for  $s = 0, 1, 2, \dots$

$$\boldsymbol{\theta}^{s+1} := \boldsymbol{\theta}^s + \mathbf{d}_s, \quad \text{where } \mathbf{d}_s = \arg \min_{\mathbf{d}} \sum_{i=1}^k \|\mathbf{e}_i(\boldsymbol{\theta}^s + \mathbf{d})\|^2 \quad (19)$$

$$\mathbf{e}_i(\boldsymbol{\theta}^s + \mathbf{d}) \approx \mathbf{e}_i(\boldsymbol{\theta}^s) + \mathbf{L}_i \mathbf{d},$$

$$(\mathbf{L}_i)_{jl} = \frac{\partial (\mathbf{e}_i(\boldsymbol{\theta}))_j}{\partial (\boldsymbol{\theta})_l}, \quad \mathbf{L}_i \in \mathbb{R}^{m,q} \quad \text{typically a long matrix, } m \ll q$$

Then the solution to Problem (19) is a set of 'normal eqs'

$$-\underbrace{\sum_{i=1}^k \mathbf{L}_i^\top \mathbf{e}_i(\boldsymbol{\theta}^s)}_{\mathbf{e} \in \mathbb{R}^{q,1}} = \underbrace{\left( \sum_{i=1}^k \mathbf{L}_i^\top \mathbf{L}_i \right)}_{\mathbf{L} \in \mathbb{R}^{q,q}} \mathbf{d}_s, \quad (20)$$

- $\mathbf{d}_s$  can be solved for by Gaussian elimination using Choleski decomposition of  $\mathbf{L}$

$\mathbf{L}$  symmetric PSD  $\Rightarrow$  use Choleski, almost  $2\times$  faster than Gauss-Seidel, see bundle adjustment →142

- beware of rank deficiency in  $\mathbf{L}$  when  $k$  is small
- such updates do not lead to stable convergence  $\rightarrow$  ideas of Levenberg and Marquardt

**Idea 2** (Levenberg): replace  $\sum_i \mathbf{L}_i^\top \mathbf{L}_i$  with  $\sum_i \mathbf{L}_i^\top \mathbf{L}_i + \lambda \mathbf{I}$  for some damping factor  $\lambda \geq 0$

**Idea 3** (Marquardt): replace  $\lambda \mathbf{I}$  with  $\lambda \sum_i \text{diag}(\mathbf{L}_i^\top \mathbf{L}_i)$  to adapt to local curvature:

$$-\sum_{i=1}^k \mathbf{L}_i^\top \mathbf{e}_i(\boldsymbol{\theta}^s) = \left( \sum_{i=1}^k (\mathbf{L}_i^\top \mathbf{L}_i + \lambda \text{diag}(\mathbf{L}_i^\top \mathbf{L}_i)) \right) \mathbf{d}_s$$

**Idea 4** (Marquardt): adaptive  $\lambda$

small  $\lambda \rightarrow$  Gauss-Newton, large  $\lambda \rightarrow$  gradient descend

1. choose  $\lambda \approx 10^{-3}$  and compute  $\mathbf{d}_s$
2. if  $\sum_i \|\mathbf{e}_i(\boldsymbol{\theta}^s + \mathbf{d}_s)\|^2 < \sum_i \|\mathbf{e}_i(\boldsymbol{\theta}^s)\|^2$  then accept  $\mathbf{d}_s$  and set  $\lambda := \lambda/10$ ,  $s := s + 1$  better: Armijo's rule
3. otherwise set  $\lambda := 10\lambda$  and recompute  $\mathbf{d}_s$

- sometimes different constants are needed for the 10 and  $10^{-3}$
- note that  $\mathbf{L}_i \in \mathbb{R}^{m,q}$  (long matrix) but each contribution  $\mathbf{L}_i^\top \mathbf{L}_i$  is a square singular  $q \times q$  matrix (always singular for  $k < q$ )
- $\lambda$  helps avoid the consequences of gauge freedom  $\rightarrow 144$
- the error function can be made robust to outliers  $\rightarrow 115$
- we have approximated the least squares Hessian by ignoring second derivatives of the error function (Gauss-Newton approximation) See [Triggs et al. 1999, Sec. 4.3]
- modern variants of LM are Trust Region methods

**Sampson** (derived by linearization over point coordinates  $u^1, v^1, u^2, v^2$ )

$$e_i(\mathbf{F}) = \frac{\varepsilon_i}{\|\mathbf{J}_i\|} = \frac{\underline{\mathbf{y}}_i^\top \mathbf{F} \underline{\mathbf{x}}_i}{\sqrt{\|\mathbf{S}\mathbf{F}\underline{\mathbf{x}}_i\|^2 + \|\mathbf{S}\mathbf{F}^\top \underline{\mathbf{y}}_i\|^2}} \quad \text{where } \mathbf{S} = \begin{bmatrix} 1 & 0 & 0 \\ 0 & 1 & 0 \end{bmatrix}$$

**LM** (by linearization over parameters  $\mathbf{F}$ )

$$\mathbf{L}_i = \frac{\partial e_i(\mathbf{F})}{\partial \mathbf{F}} = \dots = \frac{1}{2\|\mathbf{J}_i\|} \left[ \left( \underline{\mathbf{y}}_i - \frac{2e_i(\mathbf{F})}{\|\mathbf{J}_i\|} \mathbf{S}\mathbf{F}\underline{\mathbf{x}}_i \right) \underline{\mathbf{x}}_i^\top + \underline{\mathbf{y}}_i \left( \underline{\mathbf{x}}_i - \frac{2e_i(\mathbf{F})}{\|\mathbf{J}_i\|} \mathbf{S}\mathbf{F}^\top \underline{\mathbf{y}}_i \right)^\top \right] \quad (21)$$

- $\mathbf{L}_i$  in (21) is a  $3 \times 3$  matrix, must be reshaped to dimension-9 vector  $\text{vec}(\mathbf{L}_i)$  to be used in LM
- $\underline{\mathbf{x}}_i$  and  $\underline{\mathbf{y}}_i$  in Sampson error are normalized to unit homogeneous coordinate (21) relies on this
- reinforce rank  $\mathbf{F} = 2$  after each LM update to stay on the fundamental matrix manifold and  $\|\mathbf{F}\| = 1$  to avoid gauge freedom by SVD  $\rightarrow$ 111
- LM linearization could be done by numerical differentiation (we can afford it, we have a small dimension here)



## ► Local Optimization for Fundamental Matrix Estimation

### Summary so far

- Given a set  $X = \{(x_i, y_i)\}_{i=1}^k$  of  $k \gg 7$  inlier correspondences, compute a statistically efficient estimate for fundamental matrix  $\mathbf{F}$ .
  1. Find the conditioned ( $\rightarrow 92$ ) 7-point  $\mathbf{F}_0$  ( $\rightarrow 84$ ) from a suitable 7-tuple
  2. Improve the  $\mathbf{F}_0^*$  using the LM optimization ( $\rightarrow 108-109$ ) and the Sampson error ( $\rightarrow 110$ ) on all inliers, reinforce rank-2, unit-norm  $\mathbf{F}_k^*$  after each LM iteration using SVD

### Partial conceptualization

- inlier = a correspondence (a true match)
- outlier = a non-correspondence
- binary inlier/outlier labels are hidden
- we can get their likely estimate only, with respect to a model

### We are not yet done

- if there are no wrong correspondences (mismatches, outliers), this gives a local optimum given the 7-point initial estimate
- the algorithm breaks under contamination of (inlier) correspondences by outliers
- the full problem involves finding the inliers!
- in addition, we need a mechanism for jumping out of local minima (and exploring the space of all fundamental matrices)

# Example Matching Results for the 7-point Algorithm with RANSAC

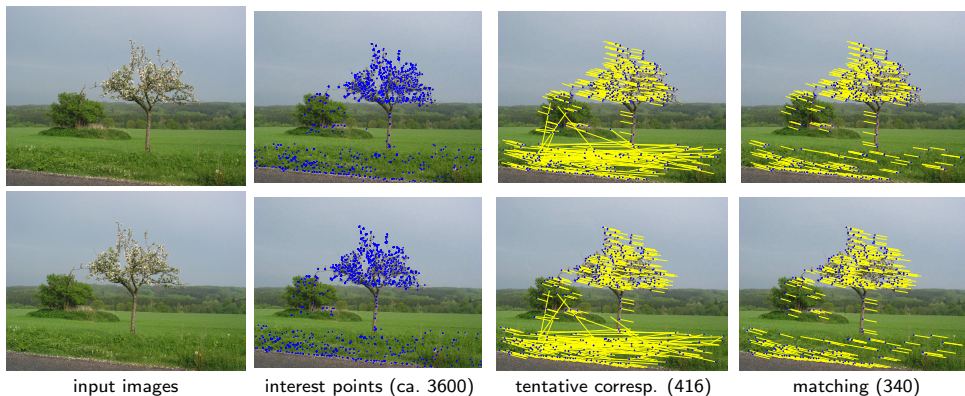

- descriptors used to obtain tentative matches but no descriptors used in the final matching
- without local optimization the minimization is over a discrete set of epipolar geometries proposable from 7-tuples
- notice some wrong matches (they have wrong depth, even negative) remember: hidden labels  $\rightarrow$ 111
- they cannot be rejected without additional constraints or scene knowledge

## ► A Preview: RANSAC with Local Optimization and Early Stopping

1. initialize the best configuration as empty  $C_{\text{best}} := \emptyset$  and proposal index  $k := 0$
2. estimate the total number of needed proposals as  $N := \binom{n}{s}$
3. while  $k \leq N$ :

$n$  – No. of primitives,  $s$  – minimal config size

- a) **propose** a minimal random configuration  $S$  of size  $s$  from  $q(S)$
- b) if  $\pi(S) > \pi(C_{\text{best}})$  then **accept**

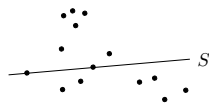

$\pi(S)$  marginalized as in (27);  $\pi(S)$  includes a prior  $\Rightarrow$  MAP

- i) update the best config  $C_{\text{best}} := S$
- ii) threshold-out inliers using  $e_T$  from (28)

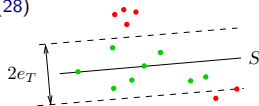

- iii) locally **optimize** from the inliers of  $C_{\text{best}}$

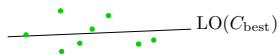

LM optimization with robustified ( $\rightarrow$ 117) Sampson error possibly weighted by posterior  $\pi(m_{ij})$  [Chum et al. 2003]

- iv) update  $C_{\text{best}}$ , update inliers using (28), re-estimate the **stopping criterion**  $N$  from inlier counts

$\rightarrow$ 126 for derivation

$$N = \frac{\log(1 - P)}{\log(1 - \varepsilon^s)}, \quad \varepsilon = \frac{|\text{inliers}(C_{\text{best}})|}{n},$$

- c)  $k := k + 1$
4. output  $C_{\text{best}}$

• see [MPV course for RANSAC details](#)

see also [Fischler & Bolles 1981], [25 years of RANSAC]

## ► Towards $\pi(S)$ : The Full Problem of Matching and Fundamental Matrix Estimation

**Problem:** Given image keypoint sets  $X = \{x_i\}_{i=1}^m$  and  $Y = \{y_j\}_{j=1}^n$  and their descriptors  $D$ , find the most probable

1. inlier keypoints  $S_X \subseteq X$ ,  $S_Y \subseteq Y$
2. one-to-one perfect matching  $M: S_X \rightarrow S_Y$
3. fundamental matrix  $\mathbf{F}$  such that  $\text{rank } \mathbf{F} = 2$
4. such that for each  $x_i \in S_X$  and  $y_j = M(x_i)$  it is probable that
  - a) the image descriptor  $D(x_i)$  is similar to  $D(y_j)$ , and
  - b) the total reprojection error  $E = \sum_{i,j} e_{ij}^2(\mathbf{F})$  is small
5. inlier-outlier and outlier-outlier matches are improbable

perfect matching: 1-factor of the bipartite graph

note a slight change in notation:  $e_{ij}$

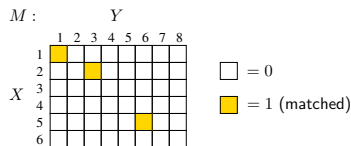
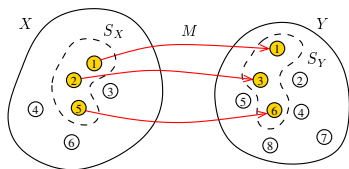

$$(M^*, \mathbf{F}^*) = \arg \max_{M, \mathbf{F}} \pi(E, D, \mathbf{F}, M) = \arg \max_{M, \mathbf{F}} p(E, D, \mathbf{F} | M) P(M) \quad (22)$$

- probabilistic model: an efficient language for problem formulation
- the (22) is a Bayesian probabilistic model
- binary matching table  $M_{ij} \in \{0, 1\}$  of fixed size  $m \times n$ 
  - each row/column contains at most one unity
  - zero rows/columns correspond to unmatched point  $x_i/y_j$

it also unifies 4.a and 4.b

there is a constant number of random variables!

## Deriving A Robust Matching Model by Approximate Marginalization

For algorithmic efficiency, instead of  $(M^*, \mathbf{F}^*) = \arg \max_{M, \mathbf{F}} p(E, D, \mathbf{F} | M) P(M)$  solve

$$\mathbf{F}^* = \arg \max_{\mathbf{F}} p(E, D, \mathbf{F}) \quad (23)$$

by marginalization of  $p(E, D, \mathbf{F} | M) P(M)$  over the set of all matchings  $\mathcal{M}$  s.t.  $M \in \mathcal{M}$  **this changes the problem!**  
drop the assumption that  $M$  is a 1:1 matching, assume correspondence-wise independence:

$$p(E, D, \mathbf{F} | M) P(M) = \prod_{i=1}^m \prod_{j=1}^n p_e(e_{ij}, d_{ij}, \mathbf{F} | m_{ij}) P(m_{ij})$$

- $e_{ij}$  represents (reprojection) error for match  $x_i \leftrightarrow y_j$ : e.g.  $e_{ij}(x_i, y_j, \mathbf{F})$
- $d_{ij}$  represents descriptor similarity for match  $x_i \leftrightarrow y_j$ : e.g.  $d_{ij} = \|\mathbf{d}(x_i) - \mathbf{d}(y_j)\|$

Approximate marginalization:

take all the  $2^{mn}$  terms in place of  $M$

$$\begin{aligned} p(E, D, \mathbf{F}) &\approx \sum_{m_{11} \in \{0,1\}} \sum_{m_{12}} \cdots \sum_{m_{mn}} p(E, D, \mathbf{F} | M) P(M) = \\ &= \sum_{m_{11}} \cdots \sum_{m_{mn}} \prod_{i=1}^m \prod_{j=1}^n p_e(e_{ij}, d_{ij}, \mathbf{F} | m_{ij}) P(m_{ij}) = \overset{\oplus}{\dots} \overset{1}{=} \\ &= \prod_{i=1}^m \prod_{j=1}^n \underbrace{\sum_{m_{ij} \in \{0,1\}} p_e(e_{ij}, d_{ij}, \mathbf{F} | m_{ij}) P(m_{ij})}_{\text{we will continue with this term}} \quad (24) \end{aligned}$$

## Robust Matching Model (cont'd)

$$\begin{aligned}
 \sum_{m_{ij} \in \{0,1\}} p_e(e_{ij}, d_{ij}, \mathbf{F} \mid m_{ij}) P(m_{ij}) &= \\
 &= \underbrace{p_e(e_{ij}, d_{ij}, \mathbf{F} \mid m_{ij} = 1)}_{p_1(e_{ij}, d_{ij}, \mathbf{F})} \underbrace{P(m_{ij} = 1)}_{1 - P_0} + \underbrace{p_e(e_{ij}, d_{ij}, \mathbf{F} \mid m_{ij} = 0)}_{p_0(e_{ij}, d_{ij}, \mathbf{F})} \underbrace{P(m_{ij} = 0)}_{P_0} = \\
 &= (1 - P_0) p_1(e_{ij}, d_{ij}, \mathbf{F}) + P_0 p_0(e_{ij}, d_{ij}, \mathbf{F}) \quad (25)
 \end{aligned}$$

- the  $p_0(e_{ij}, d_{ij}, \mathbf{F})$  is a penalty for 'missing a correspondence' but it should be a p.d.f. (cannot be a constant) →117 for a simplification

$$\text{choose } P_0 \rightarrow 1, \quad p_0(\cdot) \rightarrow 0 \quad \text{so that} \quad \frac{P_0}{1 - P_0} p_0(\cdot) \approx \text{const}$$

- the  $p_1(e_{ij}, d_{ij}, \mathbf{F})$  is typically an easy-to-design term: assuming independence of reprojection error and descriptor similarity:

$$p_1(e_{ij}, d_{ij}, \mathbf{F}) = p_1(e_{ij} \mid \mathbf{F}) p_F(\mathbf{F}) p_1(d_{ij})$$

- we choose, e.g.

$$p_1(e_{ij} \mid \mathbf{F}) = \frac{1}{T_e(\sigma_1)} e^{-\frac{e_{ij}^2(\mathbf{F})}{2\sigma_1^2}}, \quad p_1(d_{ij}) = \frac{1}{T_d(\sigma_d, \dim \mathbf{d})} e^{-\frac{\|\mathbf{d}(x_i) - \mathbf{d}(y_j)\|^2}{2\sigma_d^2}} \quad (26)$$

- $\mathbf{F}$  is a random variable and  $\sigma_1, \sigma_d, P_0$  are parameters
- the form of  $T_e(\sigma_1)$  depends on the error definition, it may depend on  $x_i, y_j$  but not on  $\mathbf{F}$
- we will continue with the result from (25)

## ► Simplified Robust Energy (Error) Function

- assuming the choice of  $p_1$  as in (26), we are simplifying (24) to

$$p(E, D, \mathbf{F}) = p(E, D | \mathbf{F}) p_F(\mathbf{F}) = p_F(\mathbf{F}) \prod_{i=1}^m \prod_{j=1}^n \left[ (1 - P_0) p_1(e_{ij}, d_{ij} | \mathbf{F}) + P_0 p_0(e_{ij}, d_{ij} | \mathbf{F}) \right]$$

- we choose  $\sigma_0 \gg \sigma_1$  and omit  $d_{ij}$  for simplicity; then the square-bracket term is

$$\frac{1 - P_0}{T_e(\sigma_1)} e^{-\frac{e_{ij}^2(\mathbf{F})}{2\sigma_1^2}} + \frac{P_0}{T_e(\sigma_0)} e^{-\frac{e_{ij}^2(\mathbf{F})}{2\sigma_0^2}} = \frac{1 - P_0}{T_e(\sigma_1)} \left( e^{-\frac{e_{ij}^2(\mathbf{F})}{2\sigma_1^2}} + \frac{T_e(\sigma_1)}{1 - P_0} \frac{P_0}{T_e(\sigma_0)} e^{-\frac{e_{ij}^2(\mathbf{F})}{2\sigma_0^2}} \right)$$

- we define the 'potential function' as:  $V(x) = -\log p(x)$ , then we maximize

$$V(E, D | \mathbf{F}) = \sum_{i=1}^m \sum_{j=1}^n \left[ \underbrace{-\log \frac{1 - P_0}{T_e(\sigma_1)}}_{\Delta = \text{const}} - \log \left( e^{-\frac{e_{ij}^2(\mathbf{F})}{2\sigma_1^2}} + \underbrace{\frac{P_0}{1 - P_0} \frac{T_e(\sigma_1)}{T_e(\sigma_0)} e^{-\frac{e_{ij}^2(\mathbf{F})}{2\sigma_0^2}}}_{t \approx \text{const}} \right) \right] =$$
$$= mn \Delta + \sum_{i=1}^m \sum_{j=1}^n \underbrace{-\log \left( e^{-\frac{e_{ij}^2(\mathbf{F})}{2\sigma_1^2}} + t \right)}_{\hat{V}(e_{ij})} \quad (27)$$

- the terms in (27) are: (constant) + (total robust error for all pairs in  $M$ )
- note we are summing over all  $mn$  matches ( $m, n$  are constant!)
- when  $t = 0$  we have quadratic inlier error function  $\hat{V}(e_{ij}) = e_{ij}^2(\mathbf{F}) / (2\sigma_1^2)$

expensive but explicit matching is avoided

## ► The Action of the Robust Matching Model on Data

Example for  $\hat{V}(e_{ij})$  from (27):

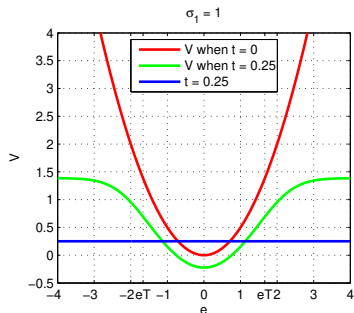

red – the (non-robust) quadratic error

blue – the rejected match penalty  $t$

green – robust  $\hat{V}(e_{ij})$  from (27)

$\hat{V}(e_{ij})$  when  $t = 0$

- if the error of a correspondence exceeds a limit, it is ignored
- then  $\hat{V}(e_{ij}) = \text{const}$  and we just count outliers in (27)
- $t$  controls the ‘turn-off’ point
- the inlier/outlier threshold is  $e_T$  – the error for which  $(1 - P_0) p_1(e_T) = P_0 p_0(e_T)$ :

note that  $t \approx 0$

$$e_T = \sigma_1 \sqrt{-\log t^2}, \quad t = e^{-\frac{1}{2} \left( \frac{e_T}{\sigma_1} \right)^2} \quad \text{e.g. } e_T = 4\sigma_1 \rightarrow t \approx 3.4 \cdot 10^{-4} \quad (28)$$

The full optimization problem (23) uses (27):

$$\mathbf{F}^* = \arg \max_{\mathbf{F}} \frac{\overbrace{p(E, D | \mathbf{F})}^{\text{data model}} \cdot \overbrace{p(\mathbf{F})}^{\text{prior}}}{\underbrace{p(E, D)}_{\text{evidence}}} \approx \arg \min_{\mathbf{F}} \left[ V(\mathbf{F}) + \sum_{i=1}^m \sum_{j=1}^n \log \left( e^{-\frac{e_{ij}^2(\mathbf{F})}{2\sigma_1^2}} + t \right) \right]$$

- typically we take  $V(\mathbf{F}) = -\log p(\mathbf{F}) = 0$  unless we need to stabilize a computation, e.g. when video camera moves smoothly (on a high-mass vehicle) and we have a prediction for  $\mathbf{F}$
- the evidence is not needed unless we want to compare different models (e.g. homography vs. epipolar geometry)



# How To Find the Global Maxima (Modes) of a PDF?

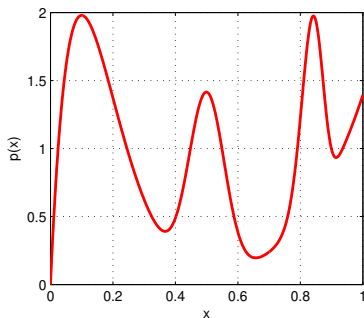

p.d.f. on  $[0, 1]$ , mode at 0.1

- given a toy probability distribution  $p(x)$  at left
- consider several methods:**

## 1. exhaustive search

```
step = 1/(iterations-1);  
for x = 0:step:1  
    if p(x) > bestp  
        bestx = x; bestp = p(x);  
    end  
end
```

- slow algorithm (definite quantization)
- fast to implement

## 2. randomized search with uniform sampling

```
while t < iterations  
    x = rand(1);  
    if p(x) > bestp  
        bestx = x; bestp = p(x);  
    end  
    t = t+1; % time  
end
```

- equally slow algorithm
- fast to implement

## 3. random sampling from $p(x)$ (Gibbs sampler)

- faster algorithm
- fast to implement but often infeasible (e.g. when  $p(x)$  is data dependent (our case in correspondence prob.))

## 4. Metropolis-Hastings sampling

- almost as fast (with care)
- not so fast to implement
- rarely infeasible
- [RANSAC belongs here](#)

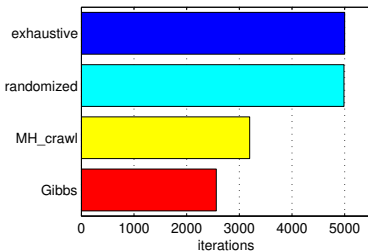

- averaged over  $10^4$  trials

- simpler (unimodal) distributions result in faster convergence

# How To Generate Random Samples from a Complex Distribution?

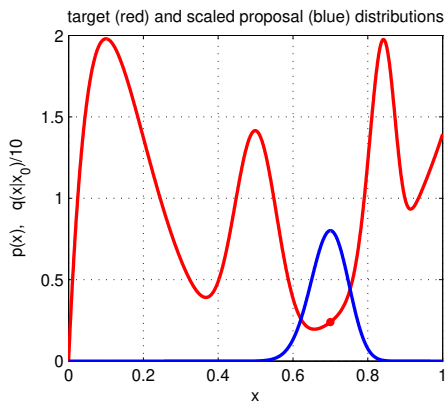

- red: probability density function  $\pi(x)$  of the toy distribution on the unit interval target distribution

$$\pi(x) = \sum_{i=1}^4 \gamma_i \text{Be}(x; \alpha_i, \beta_i), \quad \sum_{i=1}^4 \gamma_i = 1, \quad \gamma_i \geq 0$$

$$\text{Be}(x; \alpha, \beta) = \frac{1}{B(\alpha, \beta)} \cdot x^{\alpha-1} (1-x)^{\beta-1}, \quad \alpha, \beta \geq 0$$

- alg. for generating samples from  $\text{Be}(x; \alpha, \beta)$  is known
- $\Rightarrow$  we can generate samples from  $\pi(x)$  how?

- suppose we cannot sample from  $\pi(x)$  but we can sample from some 'simple' proposal distribution  $q(x | x_0)$ , given the previous sample  $x_0$  (blue)

$$q(x | x_0) = \begin{cases} U_{0,1}(x) & \text{(independent) uniform sampling} = \text{Be}(x, 1, 1) \\ \text{Be}(x; \frac{x_0}{T} + 1, \frac{1-x_0}{T} + 1) & \text{'beta' diffusion (crawler) } T - \text{temperature} \\ \pi(x) & \text{(independent) Gibbs sampler} \end{cases}$$

- note we have unified all the random sampling methods from the previous slide
- how to redistribute proposal samples  $q(x | x_0)$  to target distribution  $\pi(x)$  samples?

## ► Metropolis-Hastings (MH) Sampling

$C, S$  – configurations (of all variable values)

e.g.  $C = x$  and  $\pi(C) = \pi(x)$  from  $\rightarrow 120$

**Goal:** Generate a sequence of random samples  $\{C_t\}$  from target distribution  $\pi(C)$

- setup a Markov chain with a suitable transition probability to generate the sequence

### Sampling procedure

1. given current configuration  $C_t$ , propose (draw a random) configuration sample  $S$  from  $q(S | C_t)$

$q$  may use some information from  $C_t$  (Hastings)

2. compute acceptance probability

the redistribution filter; note the evidence term drops out

$$a = \min \left\{ 1, \frac{\pi(S)}{\pi(C_t)} \cdot \frac{q(C_t | S)}{q(S | C_t)} \right\}$$

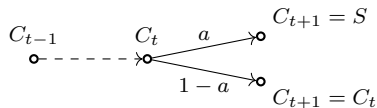

3. accept  $S$  with probability  $a$

- a) draw a random number  $u$  from unit-interval uniform distribution  $U_{0,1}$
- b) if  $u \leq a$  then  $C_{t+1} := S$  else  $C_{t+1} := C_t$

### 'Programming' an MH sampler

1. design a proposal distribution (mixture)  $q$  and a sampler from  $q$
2. express functions  $q(C_t | S)$  and  $q(S | C_t)$  as proper distributions

not always simple

### Finding the mode

- remember the best sample fast implementation but must wait long to hit the mode
- use simulated annealing very slow
- use the sampler as an explorer and do local optimization from the accepted sample a trade-off between speed and accuracy  
an optimal algorithm does not use just the best sample: a Stochastic EM Algorithm (e.g. SAEM)

# MH Sampling Demo

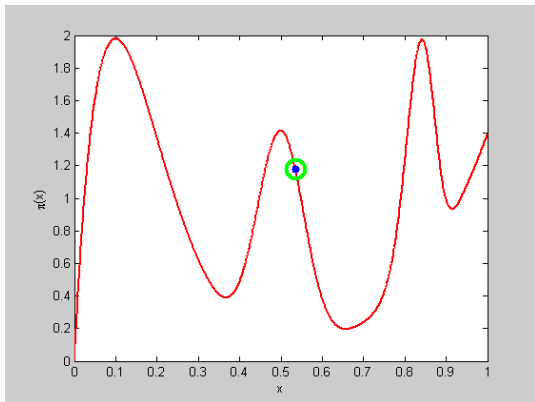

sampling process (100k samples; video, 7:33) [click for video](#)

- blue point: current sample
- green circle: best sample so far
- histogram: current distribution of visited states
- the vicinity of modes are the most often visited states

quality =  $\pi(x)$

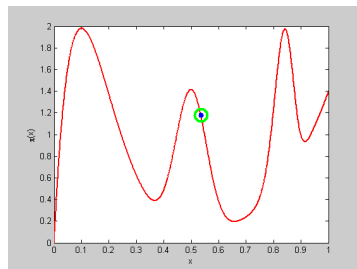

initial sample

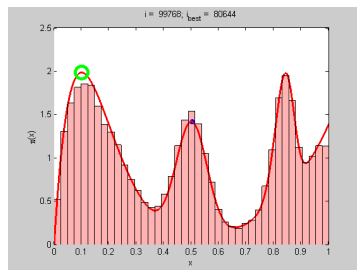

final distribution of visited states

# Demo Source Code (Matlab)

```
function x = proposal_gen(x0)
% proposal generator q(x | x0)

    T = 0.01; % temperature
    x = betarnd(x0/T+1, (1-x0)/T+1);
end

function p = proposal_q(x, x0)
% proposal distribution q(x | x0)

    T = 0.01;
    p = betapdf(x, x0/T+1, (1-x0)/T+1);
end

function p = target_p(x)
% target distribution p(x)

% shape parameters:
a = [2 40 100 6];
b = [10 40 20 1];

% mixing coefficients:
w = [1 0.4 0.253 0.50]; w = w/sum(w);
p = 0;
for i = 1:length(a)
    p = p + w(i)*betapdf(x,a(i),b(i));
end
end
```

```
%% DEMO script

k = 10000; % number of samples
X = NaN(1,k); % list of samples

x0 = proposal_gen(0.5);
for i = 1:k
    x1 = proposal_gen(x0);
    a = target_p(x1)/target_p(x0) * ...
        proposal_q(x0,x1)/proposal_q(x1,x0);
    if rand(1) < a
        X(i) = x1; x0 = x1;
    else
        X(i) = x0;
    end
end

figure(1)
x = 0:0.001:1;
plot(x, target_p(x), 'r', 'linewidth',2);
hold on
binw = 0.025; % histogram bin width
n = histc(X, 0:binw:1);
h = bar(0:binw:1, n/sum(n)/binw, 'histc');
set(h, 'facecolor', 'r', 'facealpha', 0.3)
xlim([0 1]); ylim([0 2.5])
xlabel 'x'
ylabel 'p(x)'
title 'MH demo'
hold off
```

## ► The Nine Elements of a Data-Driven MH Sampler

data-driven = proposals  $q(S | C_t)$  are derived from data

Then

1. **primitives** = elementary measurements

- points in line fitting
- matches in epipolar geometry or homography estimation

2. **configuration** =  $s$ -tuple of primitives

minimal subsets necessary for parameter estimate

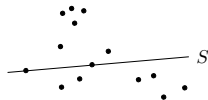

the minimization will then be over a discrete set:

- of point pairs in line fitting (left)
- of match 7-tuples in epipolar geometry estimation

3. a map from configuration  $C$  to parameters  $\theta = \theta(C)$  by solving the **minimal problem**

- line parameters  $\mathbf{n}$  from two points
- fundamental matrix  $\mathbf{F}$  from seven matches
- homography  $\mathbf{H}$  from four matches, etc

$$\begin{aligned} (\mathbf{x}^1, \mathbf{x}^2) &\mapsto \mathbf{n} \\ \{(\mathbf{x}_i^1, \mathbf{x}_i^2)\}_{i=1:7} &\mapsto \mathbf{F} \\ \{(\mathbf{x}_i^1, \mathbf{x}_i^2)\}_{i=1:4} &\mapsto \mathbf{H} \end{aligned}$$

4. **target likelihood**  $p(E, D | \theta(C))$  is represented by  $\pi(C)$

- can use log-likelihood: then it is the sum of robust errors  $\hat{V}(e_{ij})$  given  $\mathbf{F}$  (27)
  - robustified point distance from the line  $\theta = \mathbf{n}$
  - robustified Sampson error for  $\theta = \mathbf{F}$ , etc
- posterior likelihood  $p(E, D | \theta)p(\theta)$  can be used

MAPSAC ( $\pi(S)$  includes the prior)

5. parameter distribution follows the **empirical distribution** of the  $s$ -tuples of primitives. Since the proposal is done via the minimal problem solver, it is 'data-driven',

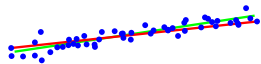

- pairs of points define line distribution  $p(\mathbf{n} | X)$  (left)
- random correspondence 7-tuples define epipolar geometry distribution  $p(\mathbf{F} | M)$

6. **proposal distribution**  $q(\cdot)$  is just a constant(!) distribution of the  $s$ -tuples:

a)  $q$  uniform, independent  $q(S | C_t) = q(S) = \binom{mn}{s}^{-1}$ , then  $a = \min \left\{ 1, \frac{p(S)}{p(C_t)} \right\}$

b)  $q$  dependent on descriptor similarity

PROSAC (similar pairs are proposed more often)

c)  $q$  dependent on the current configuration  $C_t$

e.g. 'not far from  $C_t$ '

7. (optional) hard **inlier/outlier discrimination** by the threshold (28)

$$\hat{V}(e_{ij}) < e_T, \quad e_T = \sigma_1 \sqrt{-\log t^2}$$

8. **local optimization** from promising proposals

- can use the hard inliers or just the robust error (27)
- cannot be used to replace  $C_t$

more expensive but more stable  
it would violate 'detailed balance' required for the MH scheme

9. **stopping** based on the probability of proposing an all-inlier configuration

→126

## ► Data-Driven Sampler Stopping

- The number of proposals  $N$  needed to hit the “true parameters” = an all-inlier configuration:

this will tell us nothing about the accuracy of the result

$P$  ... probability that the last proposal is an all-inlier

$\varepsilon$  ... the fraction of inliers among primitives,  $\varepsilon \leq 1$

$s$  ... No. of primitives in a minimal configuration

$1 - P$  ... all previous  $N$  proposals contained outliers

2 in line fitting, 7 in 7-point algorithm, 4 in homography fitting, ...

$$N \geq \frac{\log(1 - P)}{\log(1 - \varepsilon^s)}$$

- $\varepsilon^s$  ... proposal is all-inlier

- $1 - \varepsilon^s$  ... proposal contains at least one outlier

- $(1 - \varepsilon^s)^N$  ...  $N$  previous proposals contained an outlier =  $1 - P$

$N$  for  $s = 7$

$\varepsilon$	$P$	
	0.8	0.99
0.5	205	590
0.2	$1.3 \cdot 10^5$	$3.5 \cdot 10^5$
0.1	$1.6 \cdot 10^7$	$4.6 \cdot 10^7$

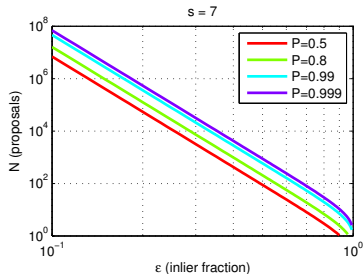

- $N$  can be re-estimated using the current estimate for  $\varepsilon$  (if there is LO, then after LO)

the quasi-posterior estimate for  $\varepsilon$  is the average over all samples generated so far

- this shows we have a good reason to limit all possible matches to tentative matches only

- for  $\varepsilon \rightarrow 0$  we gain nothing over the standard MH-sampler stopping rule

not covered in this course



## ► Stripping MH Down To Get RANSAC [Fischler & Bolles 1981]

- when we are interested in the best config only... and we need fast data exploration...
- ... then Steps 2–4 below make no difference when waiting for the best sample configuration:

### From sampling to RANSACing

1. given  $C_t$ , draw a random sample  $S$  from  $q(S|C_t)$   $q(S)$

independent sampling  
no use of information from  $C_t$

2. compute acceptance probability

$$a = \min \left\{ 1, \frac{\pi(S)}{\pi(C_t)} \cdot \frac{q(C_t | S)}{q(S | C_t)} \right\}$$

3. draw a random number  $u$  from unit interval uniform distribution  $\mathbb{U}_{0,1}$

4. if  $u \leq a$  then  $C_{t+1} := S$  else  $C_{t+1} := C_t$

5. if  $\pi(S) > \pi(C_{\text{best}})$  then remember  $C_{\text{best}} := S$

- this is the 'stupid' Method 2 from →119
- it has a good overall exploration but slow convergence in the vicinity of a mode where  $C_t$  could serve as an attractor
- getting a good accuracy configuration might take very long this way
- (possibly robust) 'local optimization' necessary for reasonable performance
- unlike the full sampler, it cannot use the past generated configurations to estimate any parameters

# The Opposite End: The Power of MH Sampler

By marginalization in (23) we have lost constraints on  $M$  (e.g. uniqueness). One can choose a better model when not marginalizing:

$$\pi(M, \mathbf{F}, E, D) = \underbrace{p(E | M, \mathbf{F})}_{\text{reprojection error}} \cdot \underbrace{p(D | M)}_{\text{similarity}} \cdot \underbrace{p(\mathbf{F})}_{\text{prior}} \cdot \underbrace{P(M)}_{\text{constraints}}$$

this is a global model: decisions on  $m_{ij}$  are no longer independent!

## In the MH scheme

- one can work with full  $p(M, \mathbf{F} | E, D)$ , then configuration  $C = M$   $\mathbf{F}$  computable from  $M$ 
  - explicit labeling  $m_{ij}$  can be done by, e.g. sampling from

$$q(m_{ij} | \mathbf{F}) \sim ((1 - P_0) p_1(e_{ij} | \mathbf{F}), P_0 p_0(e_{ij} | \mathbf{F}))$$

when  $P(M)$  uniform then always accepted,  $a = 1$

⊗ derive

- we can compute the posterior probability of each match  $p(m_{ij})$  by histogramming  $m_{ij}$  from the sequence  $\{C_i\}$
- local optimization can then use explicit inliers and  $p(m_{ij})$
- error can be estimated for the elements of  $\mathbf{F}$  from the sequence  $\{C_i\}$  does not work in RANSAC
- large error indicates problem degeneracy this is not directly available in RANSAC
- good conditioning is not a requirement we work with the entire distribution  $p(\mathbf{F})$
- one can find the most probable number of models (epipolar geometries, homographies, ...) by reversible jump MCMC  
if there are multiple models explaining data, RANSAC will return one of them randomly

# Example: MH Sampling for a More Complex Problem

**Task:** Find two vanishing points from line segments detected in input image. Principal point is known, square pixel.

iter: 10 (acc TOT=0.0%, HMC=NaN%); Eavg = 14.597

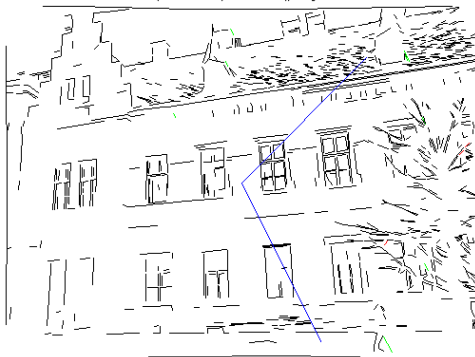

[click for video](#)

## simplifications

- vanishing points restricted to the set of all pairwise segment intersections
- mother lines fixed by segment centroid, then  $\theta_L$  uniquely given by  $\lambda_i$ , and the configuration is

$$C = \{v_1, v_2, \Lambda\}$$

- primitives = line segments
- latent variables
  1. each line has a vanishing point label  $\lambda_i \in \{\emptyset, 1, 2\}$ ,  $\emptyset$  = outlier
  2. 'mother line' parameters  $\theta_L$  (they pass through their vanishing points)
- explicit variables
  1. two unknown vanishing points  $v_1, v_2$
- marginal proposals ( $v_i$  fixed,  $v_j$  proposed)
- minimal configuration  $s = 2$

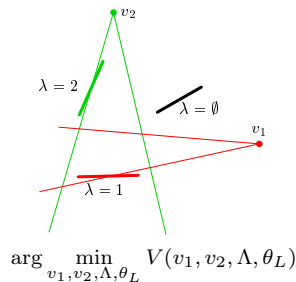

- blue lines point away from the vanishing points
- proposal acceptance: 20%
- ca. 150 iterations to a good solution

## 3D Structure and Camera Motion

6.1 Reconstructing Camera System: From Triples and from Pairs

6.2 Bundle Adjustment

### covered by

- [1] [H&Z] Secs: 9.5.3, 10.1, 10.2, 10.3, 12.1, 12.2, 12.4, 12.5, 18.1
- [2] Triggs, B. et al. Bundle Adjustment—A Modern Synthesis. In *Proc ICCV Workshop on Vision Algorithms*. Springer-Verlag. pp. 298–372, 1999.

### additional references



D. Martinec and T. Pajdla. Robust Rotation and Translation Estimation in Multiview Reconstruction. In *Proc CVPR*, 2007



M. I. A. Lourakis and A. A. Argyros. SBA: A Software Package for Generic Sparse Bundle Adjustment. *ACM Trans Math Software* 36(1):1–30, 2009.

## ► Reconstructing Camera System by Gluing Camera Triples

**Given:** Calibration matrices  $\mathbf{K}_j$  and tentative correspondences per camera triples.

### Initialization

1. initialize camera cluster  $\mathcal{C}$  with a pair  $P_1, P_2$
2. find essential matrix  $\mathbf{E}_{12}$  and matches  $M_{12}$  by the 5-point algorithm →88
3. construct camera pair

$$\mathbf{P}_1 = \mathbf{K}_1 [\mathbf{I} \quad \mathbf{0}], \quad \mathbf{P}_2 = \mathbf{K}_2 [\mathbf{R} \quad \mathbf{t}]$$

4. triangulate  $\{X_i\}$  per match from  $M_{12}$  →106
5. initialize point cloud  $\mathcal{X}$  with  $\{X_i\}$  satisfying chirality constraint  $z_i > 0$  and apical angle constraint  $|\alpha_i| > \alpha_T$

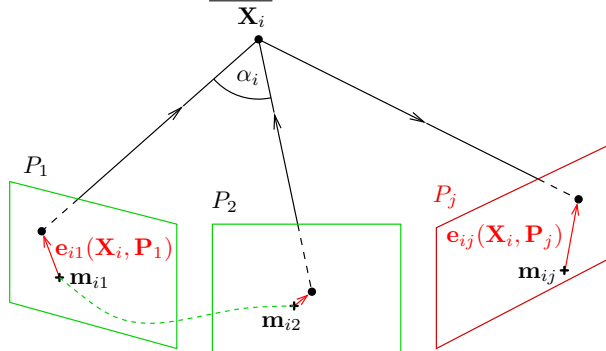

### Attaching camera $P_j \notin \mathcal{C}$

1. select points  $\mathcal{X}_j$  from  $\mathcal{X}$  that have matches to  $P_j$
2. estimate  $\mathbf{P}_j$  using  $\mathcal{X}_j$ , RANSAC with the 3-pt alg. (P3P), projection errors  $e_{ij}$  in  $\mathcal{X}_j$  →66
3. reconstruct 3D points from all tentative matches from  $P_j$  to all  $P_l, l \neq k$  that are not in  $\mathcal{X}$
4. filter them by the chirality and apical angle constraints and add them to  $\mathcal{X}$
5. add  $P_j$  to  $\mathcal{C}$
6. perform bundle adjustment on  $\mathcal{X}$  and  $\mathcal{C}$  coming next →139

## ► The Projective Reconstruction Theorem

- We can run an analogical procedure when the cameras remain uncalibrated. But:

**Observation:** Unless  $\mathbf{P}_j$  are constrained, then for any number of cameras  $j = 1, \dots, k$

$$\underline{\mathbf{m}}_{i,j} \simeq \mathbf{P}_j \underline{\mathbf{X}}_i = \underbrace{\mathbf{P}_j \mathbf{H}^{-1}}_{\mathbf{P}'_j} \underbrace{\mathbf{H} \underline{\mathbf{X}}_i}_{\underline{\mathbf{X}}'_i} = \mathbf{P}'_j \underline{\mathbf{X}}'_i$$

- when  $\mathbf{P}_i$  and  $\underline{\mathbf{X}}$  are both determined from correspondences (including calibrations  $\mathbf{K}_i$ ), they are given up to a common 3D homography  $\mathbf{H}$

(translation, rotation, scale, shear, pure perspective)

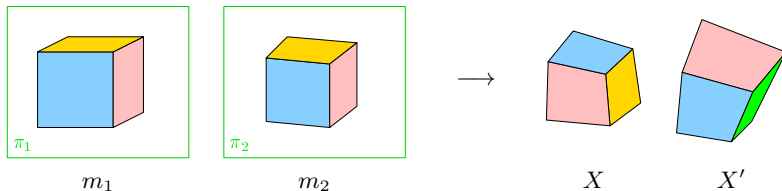

- when cameras are internally calibrated ( $\mathbf{K}_j$  known) then  $\mathbf{H}$  is restricted to a similarity since it must preserve the calibrations  $\mathbf{K}_j$   
(translation, rotation, scale)

[H&Z, Secs. 10.2, 10.3], [Longuet-Higgins 1981]

→134 for an indirect proof

## ► Reconstructing Camera System from Pairs (Correspondence-Free)

**Problem:** Given a set of  $p$  decomposed pairwise essential matrices  $\hat{\mathbf{E}}_{ij} = [\hat{\mathbf{t}}_{ij}]_{\times} \hat{\mathbf{R}}_{ij}$  and calibration matrices  $\mathbf{K}_i$  reconstruct the camera system  $\mathbf{P}_i, i = 1, \dots, k$

→81 and →151 on representing  $\mathbf{E}$

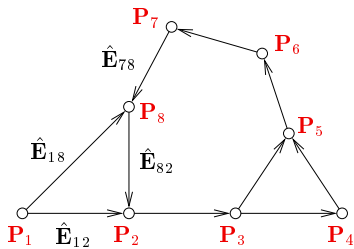

We construct calibrated camera pairs  $\hat{\mathbf{P}}_{ij} \in \mathbb{R}^{6,4}$  see (17)

$$\hat{\mathbf{P}}_{ij} = \begin{bmatrix} \mathbf{K}_i^{-1} \hat{\mathbf{P}}_i \\ \mathbf{K}_j^{-1} \hat{\mathbf{P}}_j \end{bmatrix} = \begin{bmatrix} \mathbf{I} & \mathbf{0} \\ \hat{\mathbf{R}}_{ij} & \hat{\mathbf{t}}_{ij} \end{bmatrix} \in \mathbb{R}^{6,4}$$

- singletons  $i, j$  correspond to graph nodes  $k$  nodes
- pairs  $ij$  correspond to graph edges  $p$  edges

$\hat{\mathbf{P}}_{ij}$  are in different coordinate systems but these are related by similarities  $\hat{\mathbf{P}}_{ij} \mathbf{H}_{ij} = \mathbf{P}_{ij}$   $\mathbf{H}_{ij} \in \text{SIM}(3)$

$$\underbrace{\begin{bmatrix} \mathbf{I} & \mathbf{0} \\ \hat{\mathbf{R}}_{ij} & \hat{\mathbf{t}}_{ij} \end{bmatrix}}_{\in \mathbb{R}^{6,4}} \underbrace{\begin{bmatrix} \mathbf{R}_{ij} & \mathbf{t}_{ij} \\ \mathbf{0}^{\top} & s_{ij} \end{bmatrix}}_{\mathbf{H}_{ij} \in \mathbb{R}^{4,4}} \stackrel{!}{=} \underbrace{\begin{bmatrix} \mathbf{R}_i & \mathbf{t}_i \\ \mathbf{R}_j & \mathbf{t}_j \end{bmatrix}}_{\in \mathbb{R}^{6,4}} \quad (29)$$

- (29) is a system of  $24p$  eqs. in  $7p + 6k$  unknowns  $7p \sim (\mathbf{t}_{ij}, \mathbf{R}_{ij}, s_{ij}), 6k \sim (\mathbf{R}_i, \mathbf{t}_i)$
- each  $\hat{\mathbf{P}}_i = (\mathbf{R}_i, \mathbf{t}_i)$  appears on the RHS as many times as is the degree of node  $\mathbf{P}_i$  eg.  $\mathbf{P}_5$   $3 \times$

Eq. (29) implies 
$$\begin{bmatrix} \mathbf{R}_{ij} \\ \hat{\mathbf{R}}_{ij} \mathbf{R}_{ij} \end{bmatrix} = \begin{bmatrix} \mathbf{R}_i \\ \mathbf{R}_j \end{bmatrix} \quad \text{and} \quad \begin{bmatrix} \mathbf{t}_{ij} \\ \hat{\mathbf{R}}_{ij} \mathbf{t}_{ij} + s_{ij} \hat{\mathbf{t}}_{ij} \end{bmatrix} = \begin{bmatrix} \mathbf{t}_i \\ \mathbf{t}_j \end{bmatrix}$$

- $\mathbf{R}_{ij}$  and  $\mathbf{t}_{ij}$  can be eliminated:

$$\hat{\mathbf{R}}_{ij} \mathbf{R}_i = \mathbf{R}_j, \quad \hat{\mathbf{R}}_{ij} \mathbf{t}_i + s_{ij} \hat{\mathbf{t}}_{ij} = \mathbf{t}_j, \quad s_{ij} > 0 \quad (30)$$

- note transformations that do not change these equations assuming no error in  $\hat{\mathbf{R}}_{ij}$

1.  $\mathbf{R}_i \mapsto \mathbf{R}_i \mathbf{R}$ ,
2.  $\mathbf{t}_i \mapsto \sigma \mathbf{t}_i$  and  $s_{ij} \mapsto \sigma s_{ij}$ ,
3.  $\mathbf{t}_i \mapsto \mathbf{t}_i + \mathbf{R}_i \mathbf{t}$

- the global frame is fixed, e.g. by selecting

$$\mathbf{R}_1 = \mathbf{I}, \quad \sum_{i=1}^k \mathbf{t}_i = \mathbf{0}, \quad \frac{1}{p} \sum_{i,j} s_{ij} = 1 \quad (31)$$

- rotation equations are decoupled from translation equations
- in principle,  $s_{ij}$  could correct the sign of  $\hat{\mathbf{t}}_{ij}$  from essential matrix decomposition →81  
but  $\mathbf{R}_i$  cannot correct the  $\alpha$  sign in  $\hat{\mathbf{R}}_{ij} \Rightarrow$  therefore make sure all points are in front of cameras and constrain  $s_{ij} > 0$ ; →83

+ pairwise correspondences are sufficient

- suitable for well-distributed cameras only (dome-like configurations) otherwise intractable or numerically unstable



## Finding The Rotation Component in Eq. (30)

### 1. Poor Man's Algorithm:

- create a Minimum Spanning Tree of  $\mathcal{G}$  from  $\rightarrow 133$
- propagate rotations from  $\mathbf{R}_1 = \mathbf{I}$  via  $\hat{\mathbf{R}}_{ij}\mathbf{R}_i = \mathbf{R}_j$  from (30)

### 2. Rich Man's Algorithm:

Consider  $\hat{\mathbf{R}}_{ij}\mathbf{R}_i = \mathbf{R}_j$ ,  $(i, j) \in E(\mathcal{G})$ , where  $\mathbf{R}$  are a  $3 \times 3$  rotation matrices  
Errors per columns  $c = 1, 2, 3$  of  $\mathbf{R}_j$ :

$$\mathbf{e}_{ij}^c = \hat{\mathbf{R}}_{ij}\mathbf{r}_i^c - \mathbf{r}_j^c, \quad \text{for all } i, j$$

Solve

$$\arg \min \sum_{(i,j) \in E(\mathcal{G})} \sum_{c=1}^3 (\mathbf{e}_{ij}^c)^\top \mathbf{e}_{ij}^c \quad \text{s.t.} \quad (\mathbf{r}_i^k)^\top (\mathbf{r}_j^l) = \begin{cases} 1 & i = j \wedge k = l \\ 0 & i \neq j \wedge k = l \\ 0 & i = j \wedge k \neq l \end{cases}$$

this is a quadratic programming problem

### 3. SVD-Lover's Algorithm:

Ignore the constraints and project the solution onto rotation matrices

[see next](#)

## SVD Algorithm (cont'd)

Per columns  $c = 1, 2, 3$  of  $\mathbf{R}_j$ :

$$\hat{\mathbf{R}}_{ij} \mathbf{r}_i^c - \mathbf{r}_j^c = \mathbf{0}, \quad \text{for all } i, j \quad (32)$$

- fix  $c$  and denote  $\mathbf{r}^c = [\mathbf{r}_1^c, \mathbf{r}_2^c, \dots, \mathbf{r}_k^c]^\top$   $c$ -th columns of all rotation matrices stacked;  $\mathbf{r}^c \in \mathbb{R}^{3k}$

- then (32) becomes  $\mathbf{D} \mathbf{r}^c = \mathbf{0}$

$$\mathbf{D} \in \mathbb{R}^{3p, 3k}$$

- $3p$  equations for  $3k$  unknowns  $\rightarrow p \geq k$

in a 1-connected graph we have to fix  $\mathbf{r}_1^c = [1, 0, 0]$

**Ex:** ( $k = p = 3$ )

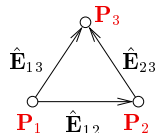

$\rightarrow$

$$\begin{aligned} \hat{\mathbf{R}}_{12} \mathbf{r}_1^c - \mathbf{r}_2^c &= \mathbf{0} \\ \hat{\mathbf{R}}_{23} \mathbf{r}_2^c - \mathbf{r}_3^c &= \mathbf{0} \\ \hat{\mathbf{R}}_{13} \mathbf{r}_1^c - \mathbf{r}_3^c &= \mathbf{0} \end{aligned}$$

$\rightarrow$

$$\mathbf{D} \mathbf{r}^c = \begin{bmatrix} \hat{\mathbf{R}}_{12} & -\mathbf{I} & \mathbf{0} \\ \mathbf{0} & \hat{\mathbf{R}}_{23} & -\mathbf{I} \\ \hat{\mathbf{R}}_{13} & \mathbf{0} & -\mathbf{I} \end{bmatrix} \begin{bmatrix} \mathbf{r}_1^c \\ \mathbf{r}_2^c \\ \mathbf{r}_3^c \end{bmatrix} = \mathbf{0}$$

- must hold for any  $c$

[Martinec & Pajdla CVPR 2007]

$\mathbf{D}$  is sparse, use  $[\mathbf{V}, \mathbf{E}] = \text{eigs}(\mathbf{D}^* \mathbf{D}, 3, 0)$ ; (Matlab)

3 smallest eigenvectors

because  $\|\mathbf{r}^c\| = 1$  is necessary but insufficient

$$\mathbf{R}_i^* = \mathbf{U} \mathbf{V}^\top, \quad \text{where } \mathbf{R}_i = \mathbf{U} \mathbf{D} \mathbf{V}^\top$$

**Idea:**

- find the space of all  $\mathbf{r}^c \in \mathbb{R}^{3k}$  that solve (32)
  - choose 3 unit orthogonal vectors in this space
  - find closest rotation matrices per cam. using SVD
- global world rotation is arbitrary

## Finding The Translation Component in Eq. (30)

From (30) and (31):

$$\hat{\mathbf{R}}_{ij} \mathbf{t}_i + s_{ij} \hat{\mathbf{t}}_{ij} - \mathbf{t}_j = \mathbf{0}, \quad \sum_{i=1}^k \mathbf{t}_i = \mathbf{0}, \quad \sum_{i,j} s_{ij} = p, \quad s_{ij} > 0, \quad \mathbf{t}_i \in \mathbb{R}^d$$

$0 < d \leq 3$  – rank of camera center set,  $p$  – #pairs,  $k$  – #cameras

- in rank  $d$ :  $d \cdot p + d + 1$  indep. eqns for  $d \cdot k + p$  unknowns  $\rightarrow p \geq \frac{d(k-1)-1}{d-1} \stackrel{\text{def}}{=} Q(d, k)$

### Ex: Chains and circuits

construction of  $\mathbf{t}_i$  from sticks of known orientation  $\hat{\mathbf{t}}_{ij}$  and unknown length  $s_{ij}$ ?

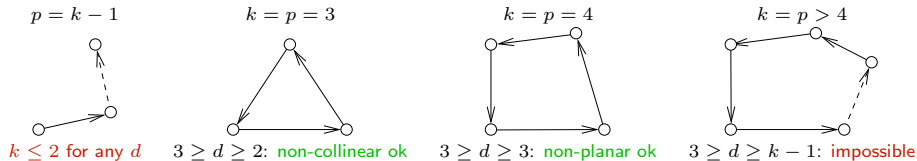

- equations insufficient for chains, trees, or when  $d = 1$

collinear cameras

- 3-connectivity implies sufficient equations for  $d = 3$

cams. in general pos. in 3D

–  $s$ -connected graph has  $p \geq \lceil \frac{sk}{2} \rceil$  edges for  $s \geq 2$ , hence  $p \geq \lceil \frac{3k}{2} \rceil \geq Q(3, k) = \frac{3k}{2} - 2$

- 4-connectivity implies sufficient eqns. for any  $k$  when  $d = 2$

coplanar cams

- since  $p \geq \lceil 2k \rceil \geq Q(2, k) = 2k - 3$
- maximal planar triangulated graphs have  $p = 3k - 6$  and give a solution for  $k \geq 3$

maximal planar triangulated graph example:

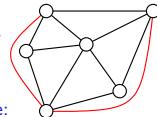

Linear equations in (30) and (31) can be rewritten to

$$\mathbf{D}\mathbf{t} = \mathbf{0}, \quad \mathbf{t} = [\mathbf{t}_1^\top, \mathbf{t}_2^\top, \dots, \mathbf{t}_k^\top, s_{12}, \dots, s_{ij}, \dots]^\top$$

assuming measurement errors  $\mathbf{D}\mathbf{t} = \epsilon$  and  $d = 3$ , we have

$$\mathbf{t} \in \mathbb{R}^{3k+p}, \quad \mathbf{D} \in \mathbb{R}^{3p, 3k+p} \quad \text{sparse}$$

and

$$\mathbf{t}^* = \arg \min_{\mathbf{t}, s_{ij} > 0} \mathbf{t}^\top \mathbf{D}^\top \mathbf{D} \mathbf{t}$$

- this is a quadratic programming problem (mind the constraints!)

```
z = zeros(3*k+p,1);
```

```
t = quadprog(D.'*D, z, diag([zeros(3*k,1); -ones(p,1)]), z);
```

- but check the rank first!

## ► Bundle Adjustment

**Goal:** Use a good (and expensive) error model and improve the initial estimates of all parameters

### Given:

1. set of 3D points  $\{\mathbf{X}_i\}_{i=1}^P$
2. set of cameras  $\{\mathbf{P}_j\}_{j=1}^C$
3. fixed tentative projections  $\mathbf{m}_{ij}$

### Required:

1. corrected 3D points  $\{\mathbf{X}'_i\}_{i=1}^P$
2. corrected cameras  $\{\mathbf{P}'_j\}_{j=1}^C$

### Latent:

1. visibility decision  $v_{ij} \in \{0, 1\}$  per  $\mathbf{m}_{ij}$

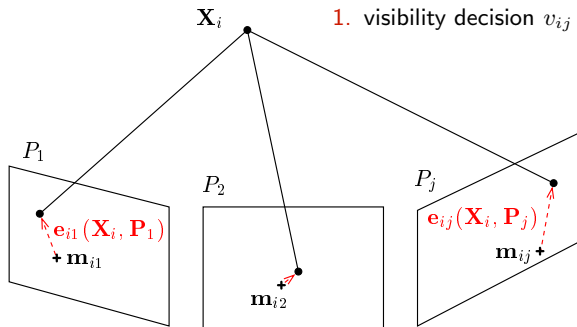

- for simplicity,  $\mathbf{X}$ ,  $\mathbf{m}$  are considered Cartesian (not homogeneous)
- we have projection error  $\mathbf{e}_{ij}(\mathbf{X}_i, \mathbf{P}_j) = \mathbf{x}_i - \mathbf{m}_i$  per image feature, where  $\mathbf{x}_i = \mathbf{P}_j \mathbf{X}_i$
- for simplicity, we will work with scalar error  $e_{ij} = \|\mathbf{e}_{ij}\|$

# Robust Objective Function for Bundle Adjustment

The data model is

constructed by marginalization over  $v_{ij}$ , as in the Robust Matching Model →116

$$p(\{\mathbf{e}\} | \{\mathbf{P}, \mathbf{X}\}) = \prod_{\text{pts: } i=1}^p \prod_{\text{cams: } j=1}^c \left( (1 - P_0) p_1(e_{ij} | \mathbf{X}_i, \mathbf{P}_j) + P_0 p_0(e_{ij} | \mathbf{X}_i, \mathbf{P}_j) \right)$$

marginalized negative log-density is (→117)

$$-\log p(\{\mathbf{e}\} | \{\mathbf{P}, \mathbf{X}\}) = \sum_i \sum_j \underbrace{-\log \left( e^{-\frac{e_{ij}^2(\mathbf{X}_i, \mathbf{P}_j)}{2\sigma_1^2}} + t \right)}_{\rho(e_{ij}^2(\mathbf{X}_i, \mathbf{P}_j)) = \nu_{ij}^2(\mathbf{X}_i, \mathbf{P}_j)} \stackrel{\text{def}}{=} \sum_i \sum_j \nu_{ij}^2(\mathbf{X}_i, \mathbf{P}_j)$$

- we can use LM,  $e_{ij}$  is the exact projection error function (not Sampson error)
- $\nu_{ij}$  is a 'robust' error fcn.; it is non-robust ( $\nu_{ij} = e_{ij}$ ) when  $t = 0$
- $\rho(\cdot)$  is a 'robustification function' often found in M-estimation
- the  $\mathbf{L}_{ij}$  in Levenberg-Marquardt changes to vector

$$(\mathbf{L}_{ij})_l = \frac{\partial \nu_{ij}}{\partial \theta_l} = \frac{1}{\underbrace{1 + t e^{e_{ij}^2(\theta)/(2\sigma_1^2)}}_{\text{small for } e_{ij} \gg \sigma_1}} \cdot \frac{1}{\nu_{ij}(\theta)} \cdot \frac{1}{4\sigma_1^2} \cdot \frac{\partial e_{ij}^2(\theta)}{\partial \theta_l} \quad (33)$$

but the LM method stays the same as before →108–109

- outliers (wrong  $v_{ij}$ ): almost no impact on  $\mathbf{d}_s$  in normal equations because the red term in (33) scales contributions to both sums down for the particular  $ij$

$$-\sum_{i,j} \mathbf{L}_{ij}^\top \nu_{ij}(\theta^s) = \left( \sum_{i,j} \mathbf{L}_{ij}^\top \mathbf{L}_{ij} \right) \mathbf{d}_s$$

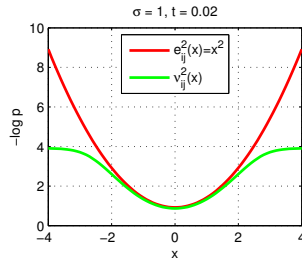

## ► Sparsity in Bundle Adjustment

We have  $q = 3p + 11k$  parameters:  $\theta = (\mathbf{X}_1, \mathbf{X}_2, \dots, \mathbf{X}_p; \mathbf{P}_1, \mathbf{P}_2, \dots, \mathbf{P}_k)$

points, cameras

We will use a multi-index  $r = 1, \dots, z$ ,  $z = p \cdot k$ . Then

$r$  correspond to point-cam pairs  $(i, j)$

$$\theta^* = \arg \min_{\theta} \sum_{r=1}^z \nu_r^2(\theta), \quad \theta^{s+1} := \theta^s + \mathbf{d}_s, \quad - \sum_{r=1}^z \mathbf{L}_r^\top \nu_r(\theta^s) = \left( \sum_{r=1}^z \mathbf{L}_r^\top \mathbf{L}_r + \lambda \operatorname{diag}(\mathbf{L}_r^\top \mathbf{L}_r) \right) \mathbf{d}_s$$

The block-form of  $\mathbf{L}_r$  in Levenberg-Marquardt ( $\rightarrow 108$ ) is zero except in columns  $i$  and  $j$ :

$r$ -th error term is  $\nu_r^2 = \rho(e_{ij}^2(\mathbf{X}_i, \mathbf{P}_j))$

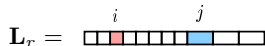

$r = (i, j)$  blocks:

:  $\mathbf{X}_i, 1 \times 3$

:  $\mathbf{P}_j, 1 \times 11$

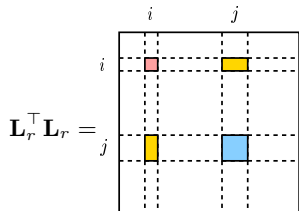

blocks:

:  $\mathbf{X}_i - \mathbf{X}_i, 3 \times 3$

:  $\mathbf{X}_i - \mathbf{P}_j, 3 \times 11$

:  $\mathbf{P}_j - \mathbf{P}_j, 11 \times 11$

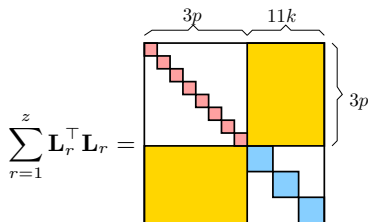

- "points-first-then-cameras" parameterization scheme

## ► Choleski Decomposition for B. A.

The most expensive computation in B. A. is solving the normal eqs:

$$\text{find } \mathbf{x} \text{ such that } \mathbf{b} \stackrel{\text{def}}{=} - \sum_{r=1}^z \mathbf{L}_r^\top \nu_r(\theta^s) = \left( \sum_{r=1}^z \mathbf{L}_r^\top \mathbf{L}_r + \lambda \text{diag}(\mathbf{L}_r^\top \mathbf{L}_r) \right) \mathbf{x} \stackrel{\text{def}}{=} \mathbf{A} \mathbf{x}$$

- $\mathbf{A}$  is very large approx.  $3 \cdot 10^4 \times 3 \cdot 10^4$  for a small problem of 10000 points and 5 cameras
- $\mathbf{A}$  is sparse and symmetric,  $\mathbf{A}^{-1}$  is dense direct matrix inversion is prohibitive

Choleski: symmetric positive definite matrix  $\mathbf{A}$  can be decomposed to  $\mathbf{A} = \mathbf{L}\mathbf{L}^\top$ , where  $\mathbf{L}$  is lower triangular. If  $\mathbf{A}$  is sparse then  $\mathbf{L}$  is sparse, too.

1. decompose  $\mathbf{A} = \mathbf{L}\mathbf{L}^\top$

$\mathbf{L} = \text{chol}(\mathbf{A})$ ; transforms the problem to  $\mathbf{L} \underbrace{\mathbf{L}^\top}_{\mathbf{c}} \mathbf{x} = \mathbf{b}$

2. solve for  $\mathbf{x}$  in two passes:

$$\mathbf{L} \mathbf{c} = \mathbf{b} \quad \mathbf{c}_i := \mathbf{L}_{ii}^{-1} \left( \mathbf{b}_i - \sum_{j < i} \mathbf{L}_{ij} \mathbf{c}_j \right) \quad \text{forward substitution, } i = 1, \dots, q \text{ (params)}$$

$$\mathbf{L}^\top \mathbf{x} = \mathbf{c} \quad \mathbf{x}_i := \mathbf{L}_{ii}^{-1} \left( \mathbf{c}_i - \sum_{j > i} \mathbf{L}_{ji} \mathbf{x}_j \right) \quad \text{back-substitution}$$

- Choleski decomposition is fast (does not touch zero blocks) non-zero elements are  $9p + 121k + 66pk \approx 3.4 \cdot 10^6$ ; ca.  $250\times$  fewer than all elements
- it can be computed on single elements or on entire blocks
- use profile Choleski for sparse  $\mathbf{A}$  and diagonal pivoting for semi-definite  $\mathbf{A}$  see above; [Triggs et al. 1999]
- $\lambda$  controls the definiteness



## Profile Choleski Decomposition is Simple

```
function L = pchol(A)
%
% PCHOL profile Choleski factorization,
%   L = PCHOL(A) returns lower-triangular sparse L such that A = L*L'
%   for sparse square symmetric positive definite matrix A,
%   especially efficient for arrowhead sparse matrices.

% (c) 2010 Radim Sara (sara@cmp.felk.cvut.cz)

[p,q] = size(A);
if p ~= q, error 'Matrix A is not square'; end

L = sparse(q,q);
F = ones(q,1);
for i=1:q
    F(i) = find(A(i,:),1); % 1st non-zero on row i; we are building F gradually
    for j = F(i):i-1
        k = max(F(i),F(j));
        a = A(i,j) - L(i,k:(j-1))*L(j,k:(j-1))';
        L(i,j) = a/L(j,j);
    end
    a = A(i,i) - sum(full(L(i,F(i):(i-1)))^2);
    if a < 0, error 'Matrix A is not positive definite'; end
    L(i,i) = sqrt(a);
end
end
```

1. The external frame is not fixed:

See Projective Reconstruction Theorem →132

$$\underline{\mathbf{m}}_{ij} \simeq \mathbf{P}_j \underline{\mathbf{X}}_i = \mathbf{P}_j \mathbf{H}^{-1} \mathbf{H} \underline{\mathbf{X}}_i = \mathbf{P}'_j \underline{\mathbf{X}}'_i$$

2. Some representations are not minimal, e.g.

- $\mathbf{P}$  is 12 numbers for 11 parameters
- we may represent  $\mathbf{P}$  in decomposed form  $\mathbf{K}, \mathbf{R}, \mathbf{t}$
- but  $\mathbf{R}$  is 9 numbers representing the 3 parameters of rotation

### As a result

- there is no unique solution
- matrix  $\sum_r \mathbf{L}_r^T \mathbf{L}_r$  is singular

### Solutions

1. fixing the external frame (e.g. a selected camera frame) explicitly or by constraints
2. fixing the scale (e.g.  $s_{12} = 1$ )
- 3a. either imposing constraints on projective entities
  - cameras, e.g.  $\mathbf{P}_{3,4} = 1$
  - points, e.g.  $(\underline{\mathbf{X}}_i)_4 = 1$  or  $\|\underline{\mathbf{X}}_i\|^2 = 1$
- 3b. or using minimal representations
  - points in their Euclidean representation  $\mathbf{X}_i$
  - rotation matrices can be represented by skew-symmetric matrices →149

this excludes affine cameras  
the 2nd: can represent points at infinity

but finite points may be an unrealistic model

# Implementing Simple Linear Constraints (by programmatic elimination)

## What for?

1. fixing external frame as in  $\theta_i = \mathbf{t}_i$ ,  $s_{kl} = 1$  for some  $i, k, l$
2. representing additional knowledge as in  $\theta_i = \theta_j$

'trivial gauge'

e.g. cameras share calibration matrix  $\mathbf{K}$

Introduce reduced parameters  $\hat{\theta}$  and replication matrix  $\mathbf{T}$ :

$$\theta = \mathbf{T} \hat{\theta} + \mathbf{t}, \quad \mathbf{T} \in \mathbb{R}^{p, \hat{p}}, \quad \hat{p} \leq p$$

then  $\mathbf{L}_r$  in LM changes to  $\mathbf{L}_r \mathbf{T}$  and everything else stays the same  $\rightarrow 108$

$$\mathbf{T} = \begin{matrix} & \hat{\theta}_1 & \hat{\theta}_2 & \hat{\theta}_3 & \hat{\theta}_4 \\ \theta_1 & 1 & & & \\ \theta_2 & & 1 & & \\ \theta_3 & & & & \\ \theta_4 & & & & 1 \\ \theta_5 & & & & 1 \end{matrix} \quad \mathbf{t} = \begin{matrix} \\ \\ 1 \\ \\ \end{matrix}$$

these  $\mathbf{T}$ ,  $\mathbf{t}$  represent

$\theta_1 = \hat{\theta}_1$	no change
$\theta_2 = \hat{\theta}_2$	no change
$\theta_3 = t_3$	constancy
$\theta_4 = \theta_5 = \hat{\theta}_4$	equality

- $\mathbf{T}$  deletes columns of  $\mathbf{L}_r$  that correspond to fixed parameters
- consistent initialisation:  $\theta^0 = \mathbf{T} \hat{\theta}^0 + \mathbf{t}$
- no need for computing derivatives for  $\theta_j$  corresponding to all-zero rows of  $\mathbf{T}$

it reduces the problem size

or filter the init by pseudoinverse  $\theta^0 \mapsto \mathbf{T}^\dagger \theta^0$

fixed  $\theta$

- constraining projective entities  $\rightarrow 149-151$
- more complex constraints tend to make normal equations dense
- implementing constraints is safer than explicit renaming of the parameters, gives a flexibility to experiment
- other methods are much more involved, see [Triggs et al. 1999]
- **BA resource:** <http://www.ics.forth.gr/~lourakis/sba/> [Lourakis 2009]

# Matrix Exponential: A path to Minimal Parameterizations

- for any square matrix we define

$$\text{expm}(\mathbf{A}) = \sum_{k=0}^{\infty} \frac{1}{k!} \mathbf{A}^k \quad \text{note: } \mathbf{A}^0 = \mathbf{I}$$

- some properties:

$$\text{expm}(x) = e^x, \quad x \in \mathbb{R}, \quad \text{expm } \mathbf{0} = \mathbf{I}, \quad \text{expm}(-\mathbf{A}) = (\text{expm } \mathbf{A})^{-1},$$

$$\text{expm}(a\mathbf{A} + b\mathbf{A}) = \text{expm}(a\mathbf{A}) \text{expm}(b\mathbf{A}), \quad \text{expm}(\mathbf{A} + \mathbf{B}) \neq \text{expm}(\mathbf{A}) \text{expm}(\mathbf{B})$$

$$\text{expm}(\mathbf{A}^\top) = (\text{expm } \mathbf{A})^\top \quad \text{hence if } \mathbf{A} \text{ is skew symmetric then } \text{expm } \mathbf{A} \text{ is orthogonal:}$$

$$(\text{expm}(\mathbf{A}))^\top = \text{expm}(\mathbf{A}^\top) = \text{expm}(-\mathbf{A}) = (\text{expm}(\mathbf{A}))^{-1}$$

$$\det(\text{expm } \mathbf{A}) = e^{\text{tr } \mathbf{A}}$$

## Some consequences

- traceless matrices ( $\text{tr } \mathbf{A} = 0$ ) map to unit-determinant matrices  $\Rightarrow$  we can represent homogeneous matrices
- skew-symmetric matrices map to orthogonal matrices  $\Rightarrow$  we can represent rotations
- matrix exponential provides the exponential map from the powerful Lie group theory

# Lie Groups Useful in 3D Vision

group		matrix	represent
special linear	$SL(3, \mathbb{R})$	real $3 \times 3$ , unit determinant $\mathbf{H}$	2D homography
special linear	$SL(4, \mathbb{R})$	real $4 \times 4$ , unit determinant $\mathbf{H}$	3D homography
special orthogonal	$SO(3)$	real $3 \times 3$ orthogonal $\mathbf{R}$	3D rotation
special Euclidean	$SE(3)$	$4 \times 4$ $\begin{bmatrix} \mathbf{R} & \mathbf{t} \\ \mathbf{0} & 1 \end{bmatrix}$ , $\mathbf{R} \in SO(3)$ , $\mathbf{t} \in \mathbb{R}^3$	3D rigid motion
similarity	$Sim(3)$	$4 \times 4$ $\begin{bmatrix} \mathbf{R} & \mathbf{t} \\ \mathbf{0} & s^{-1} \end{bmatrix}$ , $s \in \mathbb{R} \setminus 0$	rigid motion + scale

- Lie group  $G$  = topological group that is also a smooth manifold with nice properties
- Lie algebra  $\mathfrak{g}$  = vector space associated with a Lie group (tangent space of the manifold)
- group: this is where we need to work
- algebra: this is how to represent group elements with a minimal number of parameters
- Exponential map = map between algebra and its group  $\exp: \mathfrak{g} \rightarrow G$
- for matrices  $\exp = \text{expm}$
- in most of the above groups we have a closed-form formula for the exponential and for its principal inverse
- Jacobians are also readily available for  $SO(3)$ ,  $SE(3)$  [Solà 2020]

$$\mathbf{H} = \text{expm } \mathbf{Z}$$

- $\text{SL}(3, \mathbb{R})$  group element

$$\mathbf{H} = \begin{bmatrix} h_{11} & h_{12} & h_{13} \\ h_{21} & h_{22} & h_{23} \\ h_{31} & h_{32} & h_{33} \end{bmatrix} \quad \text{s.t.} \quad \det \mathbf{H} = 1$$

- $\mathfrak{sl}(3, \mathbb{R})$  algebra element

8 parameters

$$\mathbf{Z} = \begin{bmatrix} z_{11} & z_{12} & z_{13} \\ z_{21} & z_{22} & z_{23} \\ z_{31} & z_{32} & -(z_{11} + z_{22}) \end{bmatrix}$$

- note that  $\text{tr } \mathbf{Z} = 0$

## ► Rotation in 3D

$$\mathbf{R} = \expm[\boldsymbol{\phi}]_{\times}, \quad \boldsymbol{\phi} = (\phi_1, \phi_2, \phi_3) = \varphi \mathbf{e}_{\varphi}, \quad 0 \leq \varphi < \pi, \quad \|\mathbf{e}_{\varphi}\| = 1$$

- $\text{SO}(3)$  group element

$$\mathbf{R} = \begin{bmatrix} r_{11} & r_{12} & r_{13} \\ r_{21} & r_{22} & r_{23} \\ r_{31} & r_{32} & r_{33} \end{bmatrix} \quad \text{s.t.} \quad \mathbf{R}^{-1} = \mathbf{R}^{\top}$$

- $\mathfrak{so}(3)$  algebra element

$$[\boldsymbol{\phi}]_{\times} = \begin{bmatrix} 0 & -\phi_3 & \phi_2 \\ \phi_3 & 0 & -\phi_1 \\ -\phi_2 & \phi_1 & 0 \end{bmatrix}$$

3 parameters

- exponential map in closed form

Rodrigues' formula

$$\mathbf{R} = \expm[\boldsymbol{\phi}]_{\times} = \sum_{n=0}^{\infty} \frac{[\boldsymbol{\phi}]_{\times}^n}{n!} = \overset{*}{\dots} \mathbf{1} = \mathbf{I} + \frac{\sin \varphi}{\varphi} [\boldsymbol{\phi}]_{\times} + \frac{1 - \cos \varphi}{\varphi^2} [\boldsymbol{\phi}]_{\times}^2$$

- (principal) logarithm

log is a periodic function

$$0 \leq \varphi < \pi, \quad \cos \varphi = \frac{1}{2} (\text{tr}(\mathbf{R}) - 1), \quad [\boldsymbol{\phi}]_{\times} = \frac{\varphi}{2 \sin \varphi} (\mathbf{R} - \mathbf{R}^{\top}),$$

- $\boldsymbol{\phi}$  is rotation axis vector  $\mathbf{e}_{\varphi}$  scaled by rotation angle  $\varphi$  in radians
- finite limits for  $\varphi \rightarrow 0$  exist:  $\sin(\varphi)/\varphi \rightarrow 1$ ,  $(1 - \cos \varphi)/\varphi^2 \rightarrow 1/2$

$$\mathbf{M} = \text{expm} [\boldsymbol{\nu}]_{\wedge}$$

- SE(3) group element

4 × 4 matrix

$$\mathbf{M} = \begin{bmatrix} \mathbf{R} & \mathbf{t} \\ \mathbf{0} & 1 \end{bmatrix} \quad \text{s.t.} \quad \mathbf{R} \in \text{SO}(3), \mathbf{t} \in \mathbb{R}^3$$

- $\mathfrak{se}(3)$  algebra element

4 × 4 matrix

$$[\boldsymbol{\nu}]_{\wedge} = \begin{bmatrix} [\boldsymbol{\phi}]_{\times} & \boldsymbol{\rho} \\ \mathbf{0} & 0 \end{bmatrix} \quad \text{s.t.} \quad \boldsymbol{\phi} \in \mathbb{R}^3, \varphi = \|\boldsymbol{\phi}\| < \pi, \boldsymbol{\rho} \in \mathbb{R}^3$$

- exponential map in closed form

$$\mathbf{R} = \text{expm} [\boldsymbol{\phi}]_{\times}, \quad \mathbf{t} = \text{dexpm}([\boldsymbol{\phi}]_{\times}) \boldsymbol{\rho}$$

$$\text{dexpm}([\boldsymbol{\phi}]_{\times}) = \sum_{n=0}^{\infty} \frac{[\boldsymbol{\phi}]_{\times}^n}{(n+1)!} = \mathbf{I} + \frac{1 - \cos \varphi}{\varphi^2} [\boldsymbol{\phi}]_{\times} + \frac{\varphi - \sin \varphi}{\varphi^3} [\boldsymbol{\phi}]_{\times}^2$$

$$\text{dexpm}^{-1}([\boldsymbol{\phi}]_{\times}) = \mathbf{I} - \frac{1}{2} [\boldsymbol{\phi}]_{\times} + \frac{1}{\varphi^2} \left( 1 - \frac{\varphi}{2} \cot \frac{\varphi}{2} \right) [\boldsymbol{\phi}]_{\times}^2$$

- dexpm: differential of the exponential in SO(3)
- (principal) logarithm via a similar trick as in SO(3)
- finite limits exist:  $(\varphi - \sin \varphi)/\varphi^3 \rightarrow 1/6$
- this form is preferred to  $\text{SO}(3) \times \mathbb{R}^3$



## ► Minimal Representations for Other Entities

- fundamental matrix via  $SO(3) \times SO(3) \times \mathbb{R}$

$$\mathbf{F} = \mathbf{U}\mathbf{D}\mathbf{V}^\top, \quad \mathbf{D} = \text{diag}(1, d^2, 0), \quad \mathbf{U}, \mathbf{V} \in SO(3), \quad 3 + 1 + 3 = 7 \text{ DOF}$$

- essential matrix via  $SO(3) \times \mathbb{R}^3$

$$\mathbf{E} = [-\mathbf{t}]_{\times} \mathbf{R}, \quad \mathbf{R} \in SO(3), \quad \mathbf{t} \in \mathbb{R}^3, \quad \|\mathbf{t}\| = 1, \quad 3 + 2 = 5 \text{ DOF}$$

- camera pose via  $SO(3) \times \mathbb{R}^3$  or  $SE(3)$

$$\mathbf{P} = \mathbf{K} [\mathbf{R} \quad \mathbf{t}] = [\mathbf{K} \quad \mathbf{0}] \mathbf{M}, \quad 5 + 3 + 3 = 11 \text{ DOF}$$

- $Sim(3)$  useful for SfM without scale

- closed-form formulae still exist but they are a bit too messy [Eade(2017)]

- a (bit too brief) intro to Lie groups in 3D vision/robotics and SW:



J. Solà, J. Deray, and D. Atchuthan. A micro Lie theory for state estimation in robotics. [arXiv:1812.01537v7](https://arxiv.org/abs/1812.01537v7) [cs.RO], August 2020.



E. Eade. Lie groups for 2D and 3D transformations. On-line at <http://www.ethaneade.org/>, May 2017.

## Stereovision

- 7.1 Introduction
- 7.2 Epipolar Rectification
- 7.3 Binocular Disparity and Matching Table
- 7.4 Image Similarity
- 7.5 Marroquin's Winner Take All Algorithm
- 7.6 Maximum Likelihood Matching
- 7.7 Uniqueness and Ordering as Occlusion Models

### mostly covered by

Šára, R. How To Teach Stereoscopic Vision. Proc. ELMAR 2010

referenced as [SP]

### additional references



C. Geyer and K. Daniilidis. Conformal rectification of omnidirectional stereo pairs. In *Proc Computer Vision and Pattern Recognition Workshop*, p. 73, 2003.



J. Gluckman and S. K. Nayar. Rectifying transformations that minimize resampling effects. In *Proc IEEE CS Conf on Computer Vision and Pattern Recognition*, vol. 1:111–117. 2001.



M. Pollefeys, R. Koch, and L. V. Gool. A simple and efficient rectification method for general motion. In *Proc Int Conf on Computer Vision*, vol. 1:496–501, 1999.

# Stereovision: What Are The Relative Distances?



The success of a model-free stereo matching algorithm is unlikely:

## WTA Matching:

for every left-image pixel find the most similar right-image pixel along the corresponding epipolar line  
[Marroquin 83]

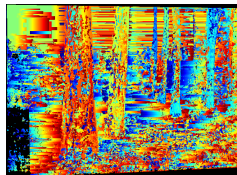

disparity map from WTA

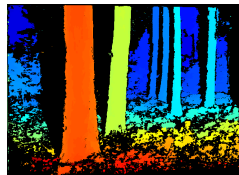

a good disparity map

- monocular vision already gives a rough 3D sketch because we understand the scene
- pixelwise independent matching without any understanding is difficult
- matching can benefit from a geometric simplification of the problem

## ► Linear Epipolar Rectification for Easier Correspondence Search

### Obs:

- if we map epipoles to infinity, epipolar lines become parallel
- we then rotate them to become horizontal
- we then scale the images to make corresponding epipolar lines colinear
- this can be achieved by a pair of (non-unique) homographies applied to the images

**Problem:** Given fundamental matrix  $\mathbf{F}$  or camera matrices  $\mathbf{P}_1, \mathbf{P}_2$ , compute a pair of homographies that maps epipolar lines to horizontal with the same row coordinate.

### Procedure:

1. find a pair of rectification homographies  $\mathbf{H}_1$  and  $\mathbf{H}_2$ .
2. warp images using  $\mathbf{H}_1$  and  $\mathbf{H}_2$  and transform the fundamental matrix  $\mathbf{F} \mapsto \mathbf{H}_2^{-T} \mathbf{F} \mathbf{H}_1^{-1}$  or the cameras  $\mathbf{P}_1 \mapsto \mathbf{H}_1 \mathbf{P}_1, \mathbf{P}_2 \mapsto \mathbf{H}_2 \mathbf{P}_2$ .

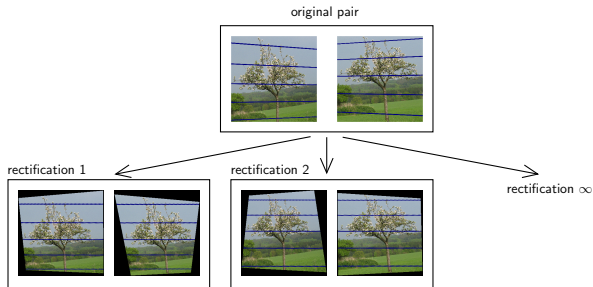

## ► Rectification Homographies

**Assumption:** Cameras  $(\mathbf{P}_1, \mathbf{P}_2)$  are rectified by a homography pair  $(\mathbf{H}_1, \mathbf{H}_2)$ :

$$\mathbf{P}_i^* = \mathbf{H}_i \mathbf{P}_i = \mathbf{H}_i \mathbf{K}_i \mathbf{R}_i [\mathbf{I} \quad -\mathbf{C}_i], \quad i = 1, 2$$

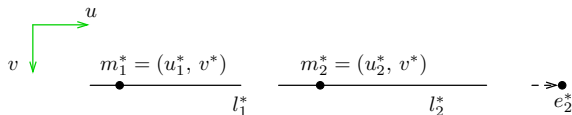

- the rectified location difference  $d = u_1^* - u_2^*$  is called disparity

**corresponding epipolar lines must be:**

1. parallel to image rows  $\Rightarrow$  epipoles become  $e_1^* = e_2^* = (1, 0, 0)$
2. equivalent  $l_2^* = l_1^*$ :  $\mathbf{l}_1^* \simeq \mathbf{e}_1^* \times \mathbf{m}_1 = [\mathbf{e}_1^*]_{\times} \mathbf{m}_1 \simeq \mathbf{l}_2^* \simeq \mathbf{F}^* \mathbf{m}_1 \Rightarrow \mathbf{F}^* = [\mathbf{e}_1^*]_{\times}$

- therefore the canonical fundamental matrix is

$$\mathbf{F}^* \simeq \begin{bmatrix} 0 & 0 & 0 \\ 0 & 0 & -1 \\ 0 & 1 & 0 \end{bmatrix}$$

### A two-step rectification procedure

1. find some pair of primitive rectification homographies  $\hat{\mathbf{H}}_1, \hat{\mathbf{H}}_2$
2. upgrade to a pair of optimal rectification homographies while preserving  $\mathbf{F}^*$

## ► Geometric Interpretation of Linear Rectification

What pair of physical cameras is compatible with  $\mathbf{F}^*$ ?

- we know that  $\mathbf{F} = (\mathbf{Q}_1 \mathbf{Q}_2^{-1})^\top [\mathbf{e}_1]_\times$
- we choose  $\mathbf{Q}_1^* = \mathbf{K}_1^*$ ,  $\mathbf{Q}_2^* = \mathbf{K}_2^* \mathbf{R}^*$ ; then

→79

$$\mathbf{F}^* \simeq (\mathbf{Q}_1^* \mathbf{Q}_2^{*-1})^\top [\mathbf{e}_1]_\times \stackrel{!}{\simeq} (\mathbf{K}_1^* \mathbf{R}^{*\top} \mathbf{K}_2^{*-1})^\top \mathbf{F}^*$$

- we look for  $\mathbf{R}^*$ ,  $\mathbf{K}_1^*$ ,  $\mathbf{K}_2^*$  compatible with

$$(\mathbf{K}_1^* \mathbf{R}^{*\top} \mathbf{K}_2^{*-1})^\top \mathbf{F}^* = \lambda \mathbf{F}^*, \quad \mathbf{R}^* \mathbf{R}^{*\top} = \mathbf{I}, \quad \mathbf{K}_1^*, \mathbf{K}_2^* \text{ upper triangular}$$

- we also want  $\mathbf{b}^*$  from  $\mathbf{e}_1^* \simeq \mathbf{P}_1^* \underline{\mathbf{C}}_2^* = \mathbf{K}_1^* \mathbf{b}^*$

$\mathbf{b}^*$  in camera-1 frame

- result:

$$\mathbf{R}^* = \mathbf{I}, \quad \mathbf{b}^* = \begin{bmatrix} b \\ 0 \\ 0 \end{bmatrix}, \quad \mathbf{K}_1^* = \begin{bmatrix} k_{11} & k_{12} & k_{13} \\ 0 & f & v_0 \\ 0 & 0 & 1 \end{bmatrix}, \quad \mathbf{K}_2^* = \begin{bmatrix} k_{21} & k_{22} & k_{23} \\ 0 & f & v_0 \\ 0 & 0 & 1 \end{bmatrix} \quad (34)$$

- rectified cameras are in canonical relative pose not rotated, canonical baseline
- rectified calibration matrices can differ in the first row only
- when  $\mathbf{K}_1^* = \mathbf{K}_2^*$  then the rectified pair is called the standard stereo pair and the homographies standard rectification homographies
- standard rectification homographies: points at infinity have zero disparity

$$\mathbf{P}_i^* \underline{\mathbf{X}}_\infty = \mathbf{K} [\mathbf{I} \quad -\mathbf{C}_i] \underline{\mathbf{X}}_\infty = \mathbf{K} \underline{\mathbf{X}}_\infty \quad i = 1, 2$$

- this does not mean that the images are not distorted after rectification

## ► Primitive Rectification

**Goal:** Given fundamental matrix  $\mathbf{F}$ , derive some easy-to-obtain rectification homographies  $\mathbf{H}_1, \mathbf{H}_2$

1. Let the SVD of  $\mathbf{F}$  be  $\mathbf{UDV}^\top = \mathbf{F}$ , where  $\mathbf{D} = \text{diag}(1, d^2, 0)$ ,  $1 \geq d^2 > 0$
2. Write  $\mathbf{D}$  as  $\mathbf{D} = \mathbf{A}^\top \mathbf{F}^* \mathbf{B}$  for some regular  $\mathbf{A}, \mathbf{B}$ . For instance

( $\mathbf{F}^*$  is given  $\rightarrow$ 155)

$$\mathbf{A} = \begin{bmatrix} 0 & 0 & 1 \\ 0 & -d & 0 \\ 1 & 0 & 0 \end{bmatrix}, \quad \mathbf{B} = \begin{bmatrix} 0 & 0 & 1 \\ 1 & 0 & 0 \\ 0 & d & 0 \end{bmatrix}$$

3. Then

$$\mathbf{F} = \mathbf{UDV}^\top = \underbrace{\mathbf{UA}^\top}_{\hat{\mathbf{H}}_2^\top} \mathbf{F}^* \underbrace{\mathbf{BV}^\top}_{\hat{\mathbf{H}}_1} = \hat{\mathbf{H}}_2^\top \mathbf{F}^* \hat{\mathbf{H}}_1 \quad \hat{\mathbf{H}}_1, \hat{\mathbf{H}}_2 \text{ orthogonal}$$

and the primitive rectification homographies are

$$\hat{\mathbf{H}}_2 = \mathbf{AU}^\top, \quad \hat{\mathbf{H}}_1 = \mathbf{BV}^\top$$

⊛ P1; 1pt: derive some other admissible  $\mathbf{A}, \mathbf{B}$

- **Hence:** Rectification homographies do exist  $\rightarrow$ 155
- there are other primitive rectification homographies, these suggested are just easy to obtain

## ► The Set of All Rectification Homographies

**Proposition 1** Homographies  $\mathbf{A}_1$  and  $\mathbf{A}_2$  are rectification-preserving if the images stay rectified, i.e. if  $\mathbf{A}_2^{-\top} \mathbf{F}^* \mathbf{A}_1^{-1} \simeq \mathbf{F}^*$ , which gives

$$\mathbf{A}_1 = \begin{bmatrix} l_1 & l_2 & l_3 \\ 0 & s_v & t_v \\ 0 & q & 1 \end{bmatrix}, \quad \mathbf{A}_2 = \begin{bmatrix} r_1 & r_2 & r_3 \\ 0 & s_v & t_v \\ 0 & q & 1 \end{bmatrix}, \quad \begin{array}{c} u \\ \rightarrow \\ \downarrow v \\ \square \end{array} \quad (35)$$

where  $s_v \neq 0$ ,  $t_v$ ,  $l_1 \neq 0$ ,  $l_2$ ,  $l_3$ ,  $r_1 \neq 0$ ,  $r_2$ ,  $r_3$ ,  $q$  are 9 free parameters.

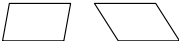
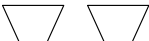
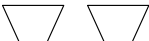
general	transformation		standard
$l_1, r_1$	horizontal scales		$l_1 = r_1$
$l_2, r_2$	horizontal shears		$l_2 = r_2$
$l_3, r_3$	horizontal shifts		$l_3 = r_3$
$q$	common special projective		
$s_v$	common vertical scale		
$t_v$	common vertical shift		
9 DoF			$9 - 3 = 6$ DoF

- $q$  is due to a rotation about the baseline
- $s_v$  changes the focal length

proof: find a rotation  $\mathbf{G}$  that brings  $\mathbf{K}$  to upper triangular form via RQ decomposition:  $\mathbf{A}_1 \mathbf{K}_1^* = \hat{\mathbf{K}}_1 \mathbf{G}$  and  $\mathbf{A}_2 \mathbf{K}_2^* = \hat{\mathbf{K}}_2 \mathbf{G}$



**Corollary for Proposition 1** Let  $\bar{\mathbf{H}}_1$  and  $\bar{\mathbf{H}}_2$  be (primitive or other) rectification homographies. Then  $\mathbf{H}_1 = \mathbf{A}_1 \bar{\mathbf{H}}_1$ ,  $\mathbf{H}_2 = \mathbf{A}_2 \bar{\mathbf{H}}_2$  are also rectification homographies, where  $\mathbf{A}_1, \mathbf{A}_2$  are as in (35).

**Proposition 2** Pairs of rectification-preserving homographies  $(\mathbf{A}_1, \mathbf{A}_2)$  form a group with group operation  $(\mathbf{A}'_1, \mathbf{A}'_2) \circ (\mathbf{A}_1, \mathbf{A}_2) = (\mathbf{A}'_1 \mathbf{A}_1, \mathbf{A}'_2 \mathbf{A}_2)$ .

**Proof:**

- closure by Proposition 1
- associativity by matrix multiplication
- identity belongs to the set
- inverse element belongs to the set by  $\mathbf{A}_2^\top \mathbf{F}^* \mathbf{A}_1 \simeq \mathbf{F}^* \Leftrightarrow \mathbf{F}^* \simeq \mathbf{A}_2^{-\top} \mathbf{F}^* \mathbf{A}_1^{-1}$

## ► Primitive Rectification Suffices for Calibrated Cameras

**Obs:** calibrated cameras:  $d = 1 \Rightarrow \hat{\mathbf{H}}_1, \hat{\mathbf{H}}_2$  ( $\rightarrow$ 157) are orthonormal

1. determine primitive rectification homographies ( $\hat{\mathbf{H}}_1, \hat{\mathbf{H}}_2$ ) from the essential matrix
2. choose a suitable common calibration matrix  $\mathbf{K}$ , e.g. from  $\mathbf{K}_1, \mathbf{K}_2$ :

$$\mathbf{K} = \begin{bmatrix} f & 0 & u_0 \\ 0 & f & v_0 \\ 0 & 0 & 1 \end{bmatrix}, \quad f = \frac{1}{2}(f^1 + f^2), \quad u_0 = \frac{1}{2}(u_0^1 + u_0^2), \quad \text{etc.}$$

3. the final rectification homographies applied as  $\mathbf{P}_i \mapsto \mathbf{H}_i \mathbf{P}_i$  are

$$\mathbf{H}_1 = \mathbf{K} \hat{\mathbf{H}}_1 \mathbf{K}_1^{-1}, \quad \mathbf{H}_2 = \mathbf{K} \hat{\mathbf{H}}_2 \mathbf{K}_2^{-1}$$

- we got a standard stereo pair ( $\rightarrow$ 156) and non-negative disparity:

$$\text{let } \mathbf{K}_i^{-1} \mathbf{P}_i = \mathbf{R}_i [\mathbf{I} \quad -\mathbf{C}_i], \quad i = 1, 2 \quad \text{note we started from } \mathbf{E}, \text{ not } \mathbf{F}$$

$$\mathbf{H}_1 \mathbf{P}_1 = \mathbf{K} \hat{\mathbf{H}}_1 \mathbf{K}_1^{-1} \mathbf{P}_1 = \mathbf{K} \underbrace{\mathbf{B} \mathbf{V}^\top \mathbf{R}_1}_{\mathbf{R}^*} [\mathbf{I} \quad -\mathbf{C}_1] = \mathbf{K} \mathbf{R}^* [\mathbf{I} \quad -\mathbf{C}_1] \quad \mathbf{A}, \mathbf{B} \text{ from } \rightarrow 157$$

$$\mathbf{H}_2 \mathbf{P}_2 = \mathbf{K} \hat{\mathbf{H}}_2 \mathbf{K}_2^{-1} \mathbf{P}_2 = \mathbf{K} \underbrace{\mathbf{A} \mathbf{U}^\top \mathbf{R}_2}_{\mathbf{R}^*} [\mathbf{I} \quad -\mathbf{C}_2] = \mathbf{K} \mathbf{R}^* [\mathbf{I} \quad -\mathbf{C}_2]$$

- one can prove that  $\mathbf{B} \mathbf{V}^\top \mathbf{R}_1 = \mathbf{A} \mathbf{U}^\top \mathbf{R}_2$  with the help of essential matrix decomposition (13)
- Note that points at infinity project by  $\mathbf{K} \mathbf{R}^*$  in both cameras  $\Rightarrow$  they have zero disparity ( $\rightarrow$ 165), hence...

## ► Summary & Remarks: Linear Rectification

... It follows: Standard rectification homographies reproject onto a common image plane parallel to the baseline

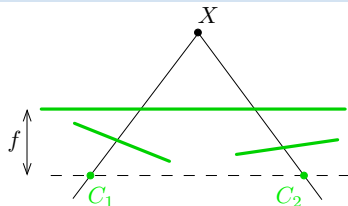

- rectification is done with a pair of homographies (one per image)
  - ⇒ projection centers of rectified cameras are equal to the original ones
    - binocular rectification: a 9-parameter family of rectification homographies
    - trinocular rectification: has 9 or 6 free parameters (depending on additional constrains)
    - in general, linear rectification is not possible for more than three cameras
- rectified cameras are in canonical orientation →156
  - ⇒ rectified image projection planes are coplanar
- equal rectified calibration matrices give standard rectification →156
  - ⇒ rectified image projection planes are equal
- primitive rectification is already standard in calibrated cameras →160
- known  $\mathbf{F}$  used alone does not allow standardization of rectification homographies
- for that we need either of these:
  1. projection matrices, or calibrated cameras, or
  2. a few points at infinity calibrating  $k_{1i}, k_{2i}, i = 1, 2, 3$  in (34)

## Optimal choice for the free parameters

- by minimization of residual image distortion, eg. [Gluckman & Nayar 2001]

$$\mathbf{A}_i^* = \arg \min_{\mathbf{A}_i} \iint_{\Omega} (\det J(\mathbf{A}_i \circ H_i(\mathbf{x})) - 1)^2 d\mathbf{x}, \quad i = 1, 2$$

- by minimization of image information loss [Matoušek, ICIG 2004]
- non-linear rectification suitable for forward motion  
non-parametric: [Pollefeys et al. 1999]  
analytic: [Geyer & Daniilidis 2003]



forward egomotion

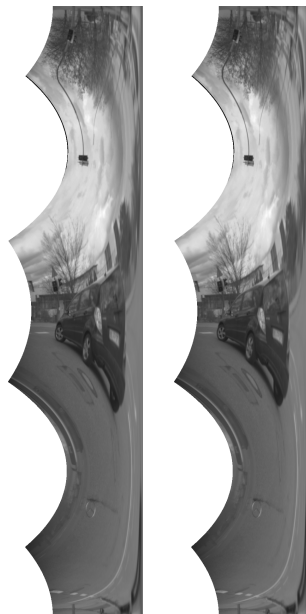

rectified images, Pollefeys' method

# How Difficult Is Stereo?

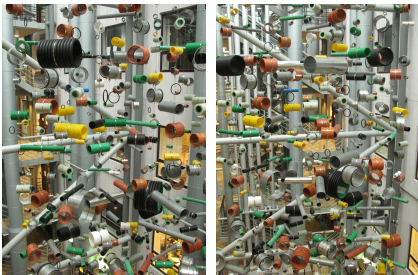

Centrum för teknikstudier at Malmö Högskola, Sweden



The Vyšehrad Fortress, Prague

- top: easy interpretation from even a single image
- bottom left: we have no help from image interpretation
- bottom right: ambiguous interpretation due to a combination of missing texture and occlusion

# A Summary of Our Observations and an Outlook

1. simple matching algorithms do not work
  - the success of a model-free stereo matching is unlikely →153
  - without scene recognition or use high-level constraints the problem seems difficult
2. stereopsis requires image interpretation in sufficiently complex scenes or another-modality measurement

we have a tradeoff: model strength  $\leftrightarrow$  universality

## Outlook:

1. represent the occlusion constraint: correspondences are not independent due to occlusions
  - disparity in rectified images
  - uniqueness as an occlusion constraint
2. represent piecewise continuity the weakest of interpretations; piecewise: object boundaries
  - ordering as a weak continuity model
3. use a consistent framework
  - finding the most probable solution (MAP)

## ► Binocular Disparity in a Standard Stereo Pair

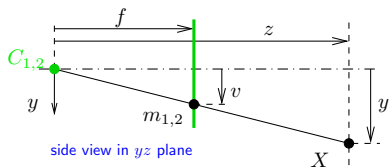
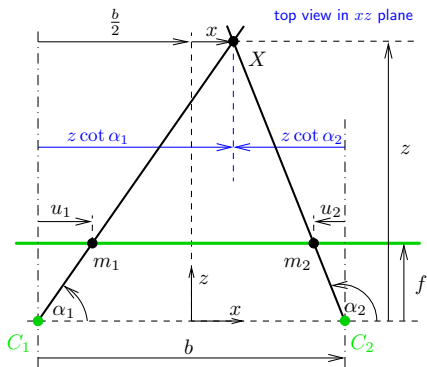

- Assumptions: single image line, standard camera pair

$$b = z \cot \alpha_1 - z \cot \alpha_2 \quad b = \frac{b}{2} + x - z \cot \alpha_2$$

$$u_1 = f \cot \alpha_1 \quad u_2 = f \cot \alpha_2$$

- eliminate  $\alpha_1, \alpha_2$  and obtain:

$X = (x, y, z)$  from **disparity**  $d = u_1 - u_2$ :

$$z = \frac{b f}{d}, \quad x = \frac{b}{d} \frac{u_1 + u_2}{2}, \quad y = \frac{b v}{d}$$

$f, d, u, v$  in pixels,  $b, x, y, z$  in meters

### Observations

- constant disparity surface is a frontoparallel plane
- distant points have small disparity
- relative error in  $z$  is large for small disparity

$$\frac{1}{z} \frac{dz}{dd} = -\frac{1}{d}$$

- increasing the baseline or the focal length increases disparity and reduces the error

# Structural Ambiguity in Stereovision

- suppose we can recognize local matches independently but have no scene model
  - lack of an occlusion model
  - lack of a continuity model
- ⇒
- structural ambiguity in the presence of repetitions (or lack of texture)

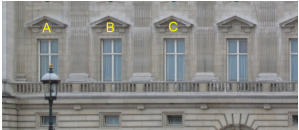

left image



right image

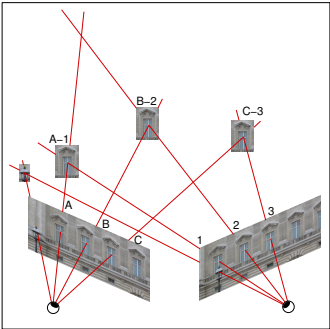

interpretation 1

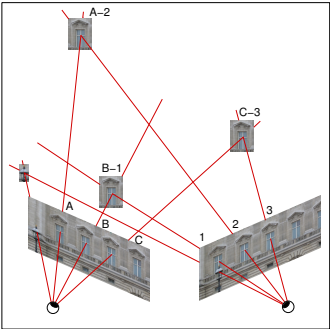

interpretation 2



## ► Understanding Basic Occlusion Types

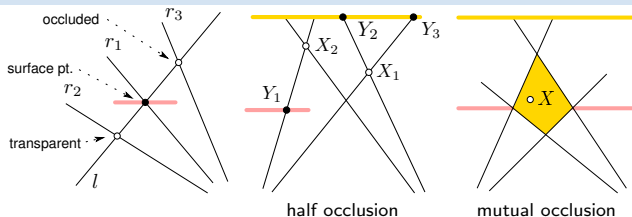

- surface point at the intersection of rays  $l$  and  $r_1$  occludes a world point at the intersection  $(l, r_3)$  and implies the world point  $(l, r_2)$  is transparent, therefore

$(l, r_3)$  and  $(l, r_2)$  are excluded by  $(l, r_1)$

- in half-occlusion, every 3D point such as  $X_1$  or  $X_2$  is excluded by a binocularly visible surface point such as  $Y_1, Y_2, Y_3$   
 $\Rightarrow$  decisions on correspondences are not independent
- in mutual occlusion this is no longer the case: any  $X$  in the yellow zone above is not excluded  
 $\Rightarrow$  decisions inside the zone are independent on the rest

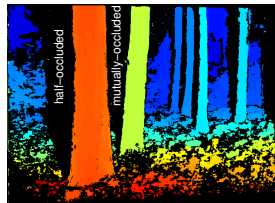

## ► Matching Table

Based on scene opacity and the observation on mutual exclusion we expect each pixel to match at most once.

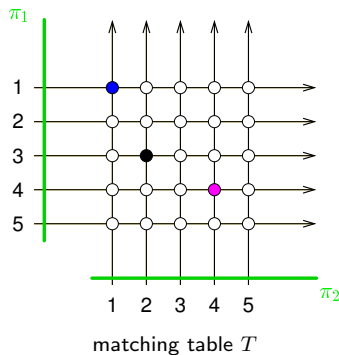
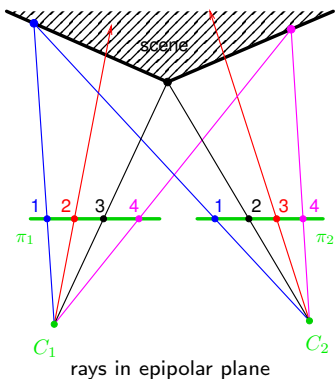

### matching table

- rows and columns represent optical rays
- nodes: possible correspondence pairs
- full nodes: matches
- numerical values associated with nodes: descriptor similarities

[see next](#)

## ► Constructing An Image Similarity Cost

- let  $p_i = (l, r)$  and  $\mathbf{L}(l)$ ,  $\mathbf{R}(r)$  be (left, right) image descriptors (vectors) constructed from local image neighborhood windows

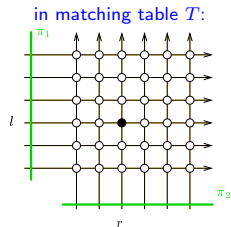

'block' in the left image  $\mapsto$  'a set of random-variable samples':

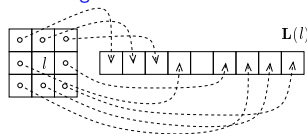

- a simple block (dis-)similarity is  $\text{SAD}(l, r) = \|\mathbf{L}(l) - \mathbf{R}(r)\|_1$   $L_1$  metric (sum of absolute differences; smaller is better)
- a scaled-descriptor (dis-)similarity is  $\text{sim}(l, r) = \frac{\|\mathbf{L}(l) - \mathbf{R}(r)\|^2}{\sigma_I^2(l, r)}$  smaller is better
- $\sigma_I^2$  – the difference scale; a suitable (plug-in) estimate is  $\frac{1}{2} [\text{var}(\mathbf{L}(l)) + \text{var}(\mathbf{R}(r))]$ , giving

$$\text{sim}(l, r) = 1 - \frac{2 \text{cov}(\mathbf{L}(l), \mathbf{R}(r))}{\underbrace{\text{var}(\mathbf{L}(l)) + \text{var}(\mathbf{R}(r))}_{\rho(\mathbf{L}(l), \mathbf{R}(r))}} \quad \text{var}(\cdot), \text{cov}(\cdot) \text{ is sample (co-)variance, not invariant to scale difference} \quad (36)$$

- $\rho$  – MNCC – Moravec's Normalized Cross-Correlation similarity bigger is better [Moravec 1977]

$$\rho^2 \in [0, 1], \quad \text{sign } \rho \sim \text{'phase'}$$

- another successful (dis-)similarity is the Hamming Distance over the Census Transform related to local binary patterns

# How A Scene Looks in The Filled-In Matching Table

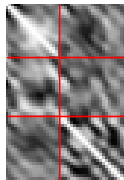
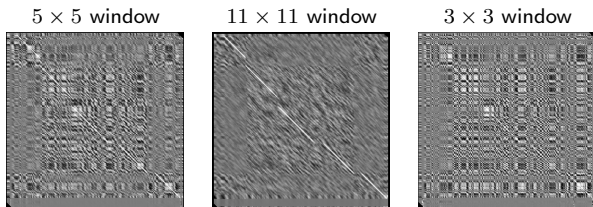
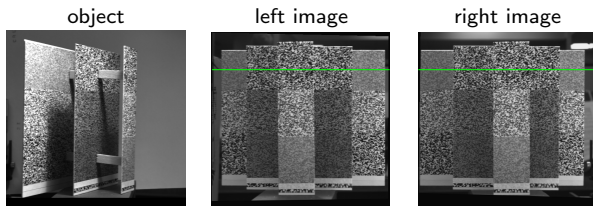

a good tradeoff

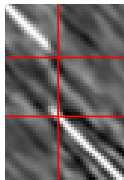

occlusion artefacts

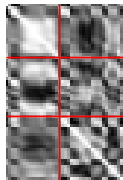

undiscriminable

- MNCC  $\rho$  used  
( $\alpha = 1.5, \beta = 1$ )
- high-similarity structures correspond to scene objects

→176

## Things to notice:

### constant disparity

- a diagonal in matching table
- zero disparity is the main diagonal  
assuming standard stereopair

### depth discontinuity

- horizontal or vertical jump in matching table

### large image window

- similarity values have better discriminability
- worse occlusion localization

### repeated texture

- horizontal and vertical block repetition

# Image Point Descriptors And Their Similarity

**Descriptors:** Image points are tagged by their (viewpoint-invariant) physical properties:

- texture window
  - a descriptor like DAISY
  - learned descriptors
  - reflectance profile under a moving illuminant
  - photometric ratios
  - dual photometric stereo
  - polarization signature
  - ...
- similar points are more likely to match
  - image similarity values for all 'match candidates' give the 3D matching table

[Moravec 77]  
[Tola et al. 2010]

[Wolff & Angelopoulou 93-94]  
[Ikeuchi 87]

also called: 'disparity volume'

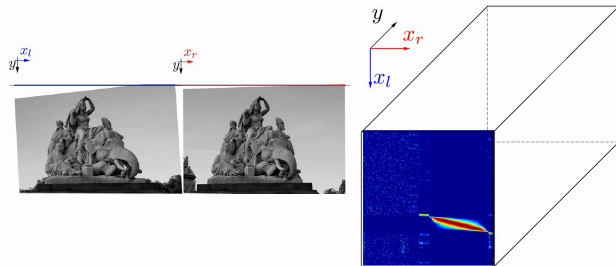

[click for video](#)

## ► Marroquin's Winner Take All (WTA) Matching Algorithm

**Alg:** Per left-image pixel: The most SAD-similar pixel along the right epipolar line

→169

1. select disparity range
2. represent the matching table diagonals in a compact form

this is a critical weak point

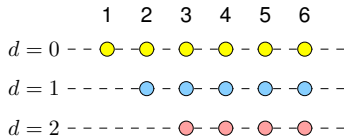
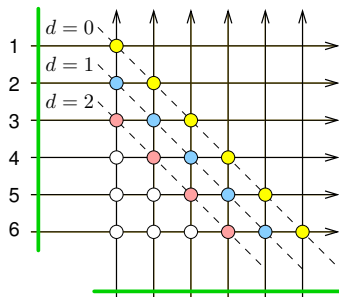

3. use an 'image sliding & cost aggregation algorithm'
4. take the maximum over disparities  $d$
5. threshold results by the maximal allowed SAD dissimilarity

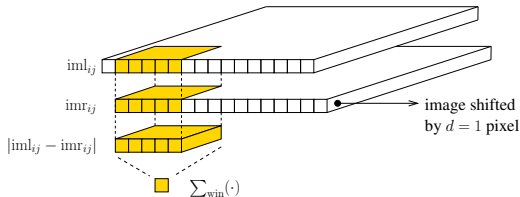

# A Matlab Code for WTA

```
function dmap = marroquin(impl, imr, disparityRange)
%     impl, imr - rectified gray-scale images
% disparityRange - non-negative disparity range

% (c) Radim Sara (sara@cmp.felk.cvut.cz) FEE CTU Prague, 10 Dec 12

thr = 20; % bad match rejection threshold
r = 2;
winsize = 2*r+[1 1]; % 5x5 window (neighborhood) for r=2
N = boxing(ones(size(impl)), winsize); % the size of each local patch is
% N = (2r+1)^2 except for boundary pixels

% --- compute dissimilarity per pixel and disparity --->
for d = 0:disparityRange % cycle over all disparities
    slice = abs(imr(:,1:end-d) - impl(:,d+1:end)); % pixelwise dissimilarity (unscaled SAD)
    V(:,d+1:end,d+1) = boxing(slice, winsize)./N; % window aggregation
end

% --- collect winners, threshold, output disparity map --->

[cmap,dmap] = min(V,[],3); % collect winners and their dissimilarities
dmap(cmap > thr) = NaN; % mask-out high dissimilarity pixels
end % of marroquin

function c = boxing(im, wsz)
% if the mex is not found, run this slow version:
c = conv2(ones(1,wsz(1)), ones(wsz(2),1), im, 'same');
end % of boxing
```

# WTA: Some Results



thr = 20

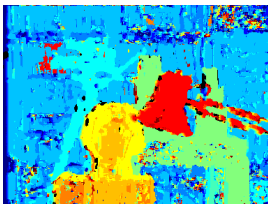

thr = 10

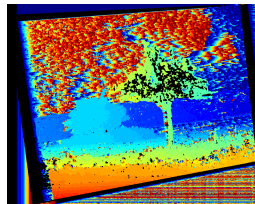
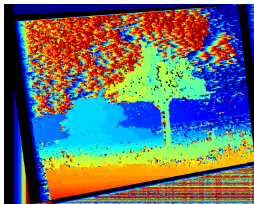
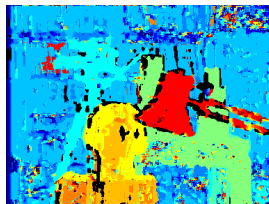

- results are fairly bad
- false matches in textureless image regions and on repetitive structures (book shelf)
- a more restrictive threshold ( $\text{thr} = 10$ ) does not work as expected
- we searched the true disparity range, results get worse if the range is set wider
- chief failure reasons:
  - unnormalized image dissimilarity does not work well
  - no occlusion model (it just ignores the occlusion structure we have discussed →167)



## ► A Principled Approach to Similarity

Empirical Distribution of MNCC  $\rho$  for Matches (green) and Non-Matches (red)

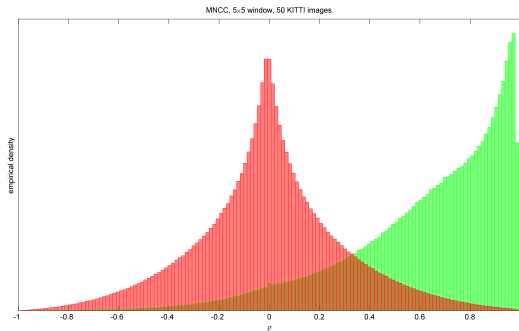

- histograms of  $\rho$  computed from  $5 \times 5$  correlation window
- KITTI dataset
  - $4.2 \cdot 10^6$  ground-truth (LiDAR) matches for  $p_1(\rho)$  (green),
  - $4.2 \cdot 10^6$  random non-matches for  $p_0(\rho)$  (red)

$\rho$ : bigger is better

### Obs:

- non-matches (red) may have arbitrarily large  $\rho$
- matches (green) may have arbitrarily low  $\rho$
- $\rho = 1$  is improbable for matches

# Match Likelihood

- $\rho$  is just a normalized measurement
- we need a probability distribution on  $[0, 1]$ , e.g. Beta distribution

$$p_1(\rho) = \frac{1}{B(\alpha, \beta)} |\rho|^{\alpha-1} (1 - |\rho|)^{\beta-1}$$

- note that uniform distribution is obtained for  $\alpha = \beta = 1$
- when  $\alpha = 2$  and  $\beta = 1$  then  $p_1(\cdot) = 2|\rho|$

- the mode is at  $\sqrt{\frac{\alpha-1}{\alpha+\beta-2}} \approx 0.9733$  for  $\alpha = 10, \beta = 1.5$
- if we chose  $\beta = 1$  then the mode was at  $\rho = 1$
- perfect similarity is 'suspicious' (depends on expected camera noise level)
- from now on we will work with negative log-likelihood cost

$$V_1(\rho(l, r)) = -\log p_1(\rho(l, r)) \quad \text{smaller is better} \quad (37)$$

- we should also define similarity (and negative log-likelihood  $V_0(\rho(l, r))$ ) for non-matches

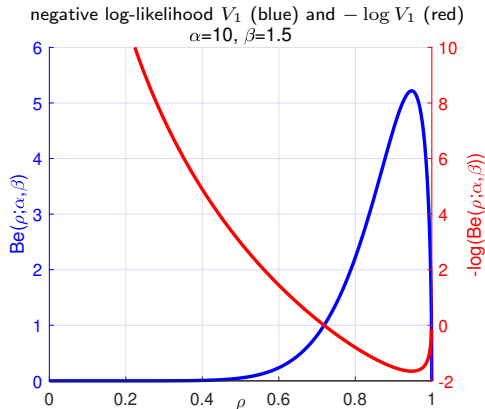

## ► A Principled Approach to Matching: Formulating ‘What We Want’

- given matching  $M$  in table  $T$ , what is the likelihood of observed data  $D$ ?
- data – all cost pairs  $(V_0, V_1)$  in the matching table  $T$
- matches – pairs  $p_i = (l_i, r_i) \in M \subset T, \quad i = 1, \dots, n$
- matching: partitioning matching table  $T$  to matched  $M$  and excluded  $E$  pairs

$$T = M \cup E, \quad M \cap E = \emptyset$$

- matching cost (negative log-likelihood, smaller is better) constant number of variables in  $T$

$$V(D | M, T) = \sum_{p \in M} V_1(D | p) + \sum_{p \in T \setminus M} V_0(D | p)$$

$V_1(D | p)$  – negative log-probability of data  $D$  at matched pixel  $p$  (37)

$V_0(D | p)$  – ditto at unmatched pixel  $p$

→175 and →176

- matching problem

$$M^* = \arg \min_{M \in \mathcal{M}(T)} V(D | M, T)$$

$\mathcal{M}(T)$  – the set of all matchings in table  $T$

- symmetric: formulated over pairs, invariant to left  $\leftrightarrow$  right image swap

unlike in WTA

## ► (cont'd) Log-Likelihood Ratio

- we need to reduce matching to a standard polynomial-complexity problem
- convert the matching cost to an 'easier' sum

$$\begin{aligned} V(D | M, T) &= \sum_{p \in M} V_1(D | p) + \sum_{p \in T \setminus M} V_0(D | p) + \overbrace{\sum_{p \in M} V_0(D | p) - \sum_{p \in M} V_0(D | p)}^0 \\ &= \sum_{p \in M} \underbrace{\left( V_1(D | p) - V_0(D | p) \right)}_{-L(D | p)} + \underbrace{\sum_{p \in T \setminus M} V_0(D | p) + \sum_{p \in M} V_0(D | p)}_{\sum_{p \in T} V_0(D | p) = \text{const}} \end{aligned}$$

- hence

$$\arg \min_{M \in \mathcal{M}(T)} V(D | M) = \arg \max_{M \in \mathcal{M}(T)} \sum_{p \in M} L(D | p) \quad (38)$$

$L(D | p)$  – logarithm of matched-to-unmatched likelihood ratio (bigger is better)

why this way: we want to use maximum-likelihood on the entire  $T$

- (38) is max-cost matching (maximum assignment) for the maximum-likelihood (ML) matching problem
  - use Hungarian (Munkres) algorithm and threshold the result with  $\tau$ :  $L(D | p) > \tau \geq 0$   
or approximate the problem by sacrificing symmetry to speed and use dynamic programming

# Some Results for the Maximum-Likelihood (ML) Matching

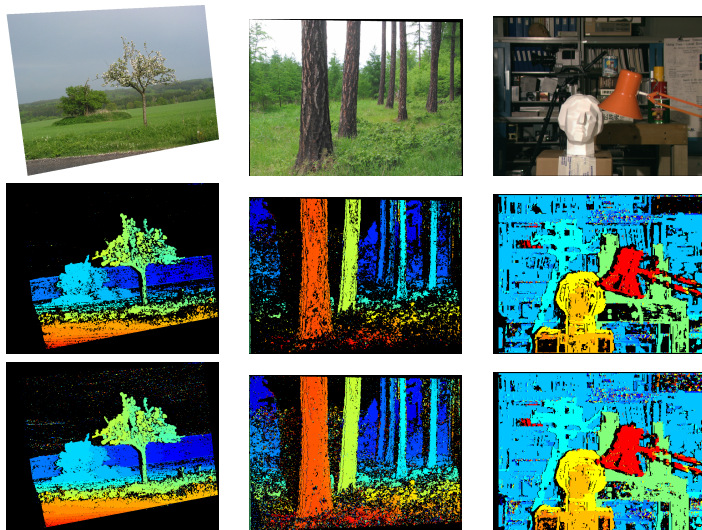

- unlike the WTA we can efficiently control the density/accuracy tradeoff with  $\tau$
- middle row: threshold  $\tau$  for  $L(D | p)$  set to achieve error rate of 3% (and 61% density results)
- bottom row: threshold  $\tau$  set to achieve density of 76% (and 4.3% error rate results)

black = no match

## ► Basic Stereoscopic Matching Models

- notice many small isolated errors in the ML matching
- Q: how to reduce the noisiness? A: a stronger model

### Potential models for $M$ (from weaker to stronger)

#### 1. Uniqueness: Every image point matches at most once

- excludes semi-transparent objects
- used in the ML matching algorithm (but not in the WTA algorithm)

#### 2. Monotonicity: Matched pixel ordering is preserved →181

- for all  $(i, j) \in M, (k, l) \in M, k > i \Rightarrow l > j$

Notation:  $(i, j) \in M$  or  $j = M(i)$  – left-image pixel  $i$  matches right-image pixel  $j$

- excludes thin objects close to the cameras
- used in 3-Label Dynamic Programming (3LDP) [SP]

#### 3. Coherence: Objects occupy well-defined 3D volumes

- concept by [Prazdny 85]
- algorithms are based on image/disparity map segmentation
- a popular model (segment-based, bilateral filtering and their successors)
- used in Stable Segmented 3LDP [Aksoy et al. PRRS 2008]

#### 4. (Piecewise) binocular continuity: The scene images continuously w/o self-occlusions

- disparities do not differ much in neighboring pixels (except at object boundaries)
- full binocular continuity too strong, except in some applications
- piecewise binocular continuity is combined with monotonicity in 3LDP

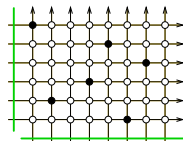

incoherent

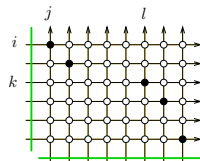

monotonic coherent

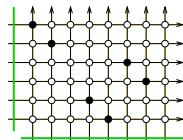

non-monotonic coherent

# Binocular Discontinuities in Matching Table

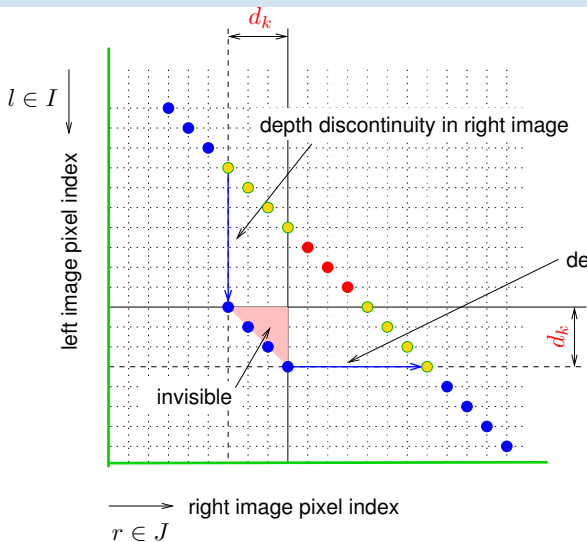

- binocularly visible foreground points
  - binocularly visible background pts violating ordering
  - monocularly visible points
- $d_k$  critical disparity

- this leads to the concept of 'forbidden zone'

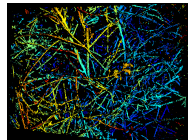
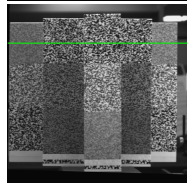
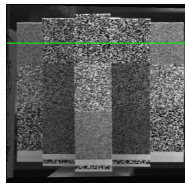
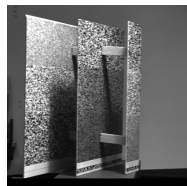
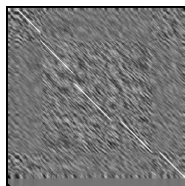

GCS

## ► Formally: Uniqueness and Ordering in Matching Table $T$

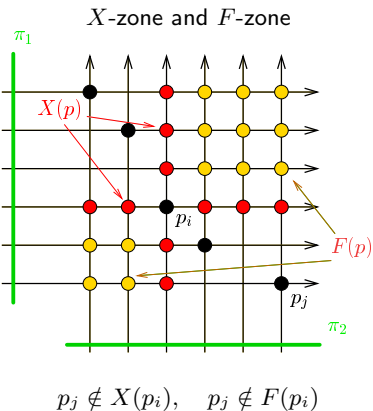

- **Uniqueness Constraint:**

A set of pairs  $M = \{p_i\}_{i=1}^n, p_i \in T$  is a matching iff  
 $\forall p_i, p_j \in M : p_j \notin X(p_i).$

$X$ -zone,  $p_i \notin X(p_i)$

- **Ordering Constraint:**

Matching  $M$  is monotonic iff  
 $\forall p_i, p_j \in M : p_j \notin F(p_i).$

$F$ -zone,  $p_i \notin F(p_i)$

- ordering constraint: matched points form a monotonic set in both images
  - ordering is a powerful constraint: in  $n \times n$  table we have monotonic matchings  $O(4^n) \ll O(n!)$  all matchings
- ⊗ 2: how many are there maximal monotonic matchings? (e.g. 27 for  $n = 4$ ; hard!)

- uniqueness constraint is a basic occlusion model
- ordering constraint is a weak continuity model
- monotonic matching can be found by **dynamic programming**

and partly also an occlusion model



# Some Results: AppleTree



left image



right image

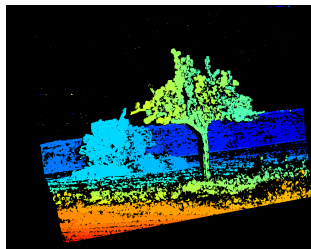

ML  $\rightarrow$ 178

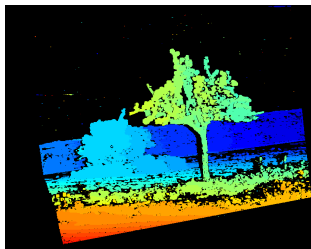

3LDP w/ordering  
[SP]

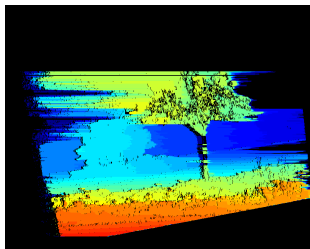

naïve DP  
[Cox et al. 1992]

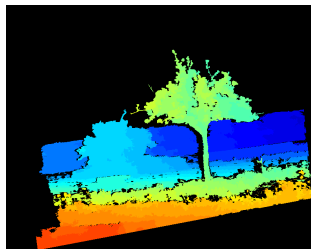

Stable Segmented 3LDP  
[Aksoy et al. PRRS 2008]

- 3LDP parameters  $\alpha_i$ ,  $V_e$  learned on Middlebury stereo data

<http://vision.middlebury.edu/stereo/>

## Some Results: Larch



left image



right image

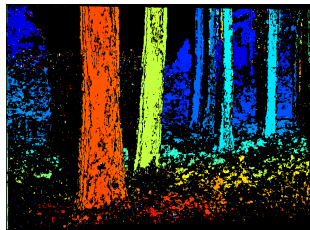

ML →178

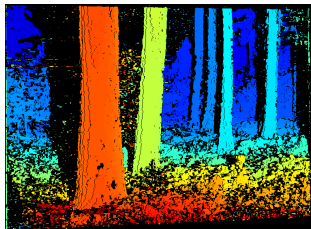

3LDP w/ordering [SP]

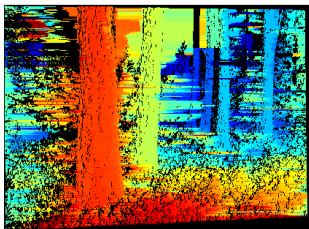

naïve DP

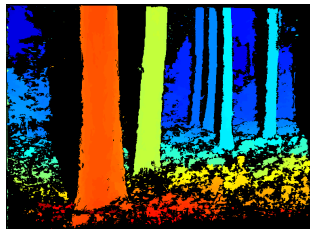

Stable Segmented 3LDP

- naïve DP: no mutual occlusion model, ignores symmetry, has no similarity distribution model, ignores  $T \setminus M$
- but even 3LDP has errors in mutually occluded region
- Stable Segmented 3LDP: few errors in mutually occluded region since it uses a coherence model

# Algorithm Comparison

## Marroquin's Winner-Take-All (WTA →172)

- the ur-algorithm very weak model
- dense disparity map
- $O(N^3)$  algorithm, simple but it rarely works

## Maximum Likelihood Matching (ML →178)

- semi-dense disparity map
- many small isolated errors
- models basic occlusion
- $O(N^3 \log(NV))$  algorithm max-flow by cost scaling

## MAP with Min-Cost Labeled Path (3LDP)

- semi-dense disparity map
- models occlusion in flat, piecewise binocularly continuous scenes
- has 'illusions' if ordering does not hold
- $O(N^3)$  algorithm

## Stable Segmented 3LDP

- better than 3LDP fewer errors at any given density
- $O(N^3 \log N)$  algorithm
- requires image segmentation itself a difficult task

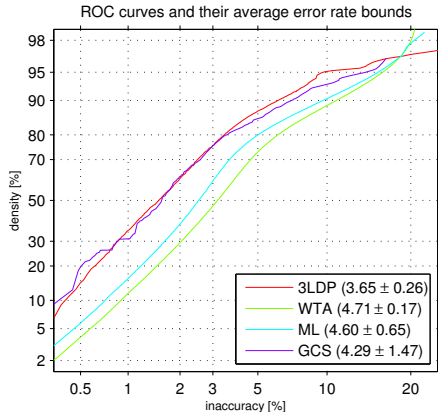

- ROC-like curve captures the density/accuracy tradeoff
- numbers: AUC (smaller is better)
- GCS is the one used in the exercises
- more algorithms at <http://vision.middlebury.edu/stereo/> (good luck!)

# A Summary of This Course Highlights

- homography as a two-image model
- epipolar geometry as a two-image model
- core algorithms for 3D vision:
  - simple intrinsic calibration methods
  - 6-pt alg for camera resection and 3-pt alg for exterior orientation (calibrated resection)
  - 7-pt alg for fundamental matrix, 5-pt alg for essential matrix
  - essential matrix decomposition to rotation and translation
  - efficient accurate triangulation
  - robust matching by RANSAC sampling
  - camera system reconstruction
  - efficient bundle adjustment
  - stereoscopic matching basics
- statistical robustness as a way to work with partially unknown information

## What can we do with these tools?

- perspective image rectification
- 3D scene reconstruction
- motion capture
- visual odometry
- robotic self-localization and mapping (SLAM) for navigation and motion planning

we did not cover 3D aggregation in scene maps

Thank You

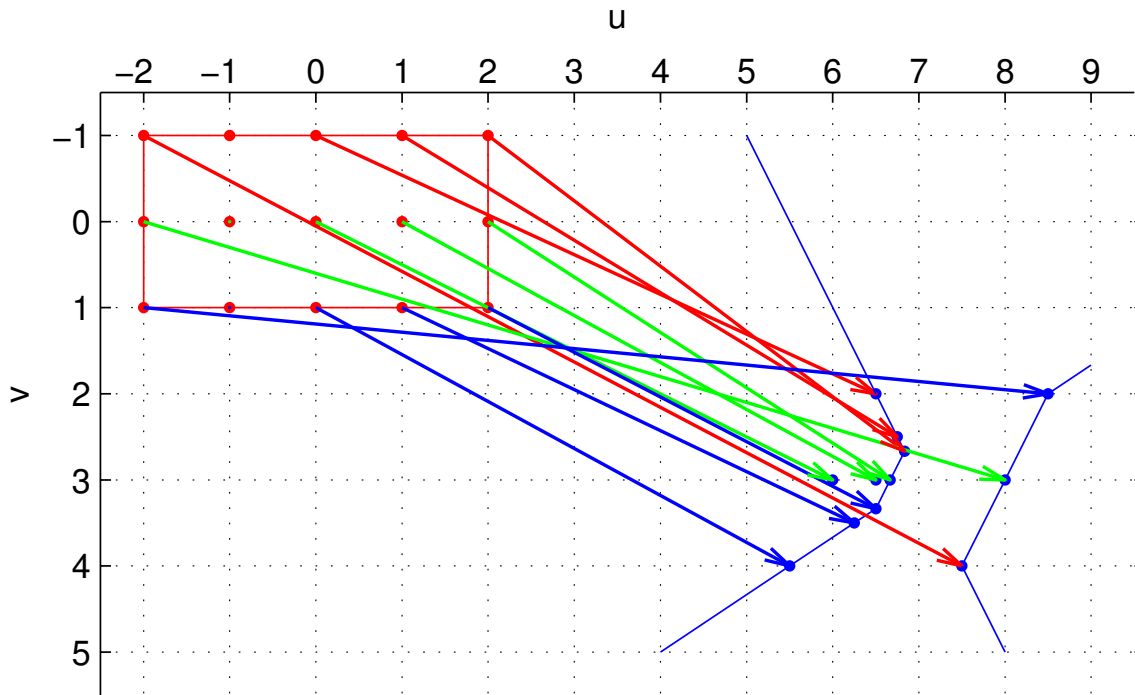

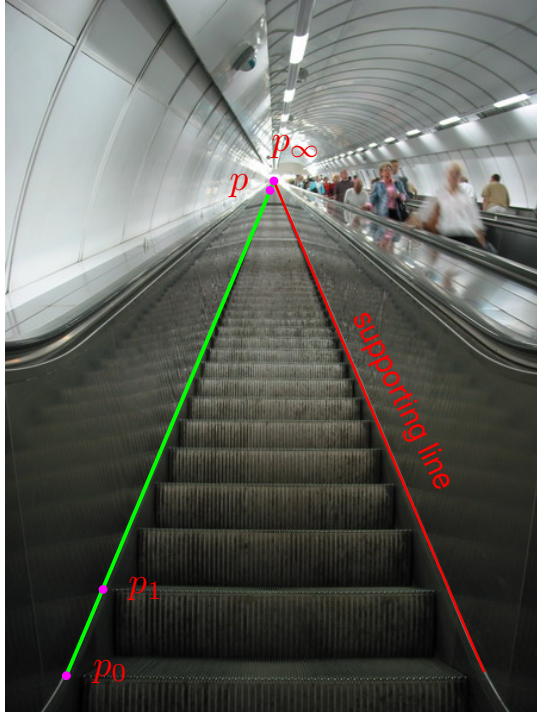

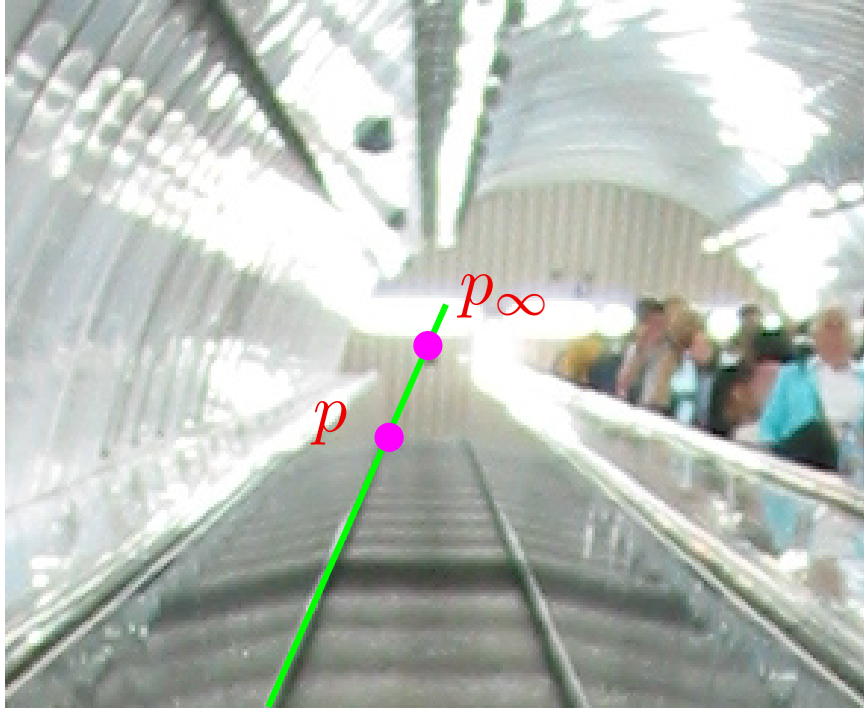





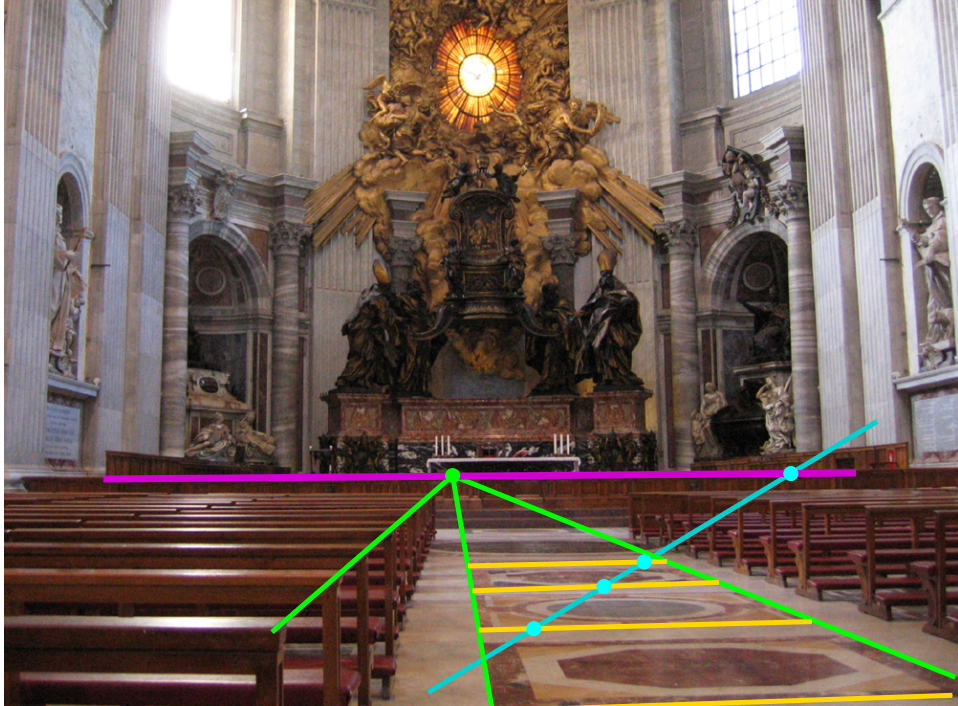





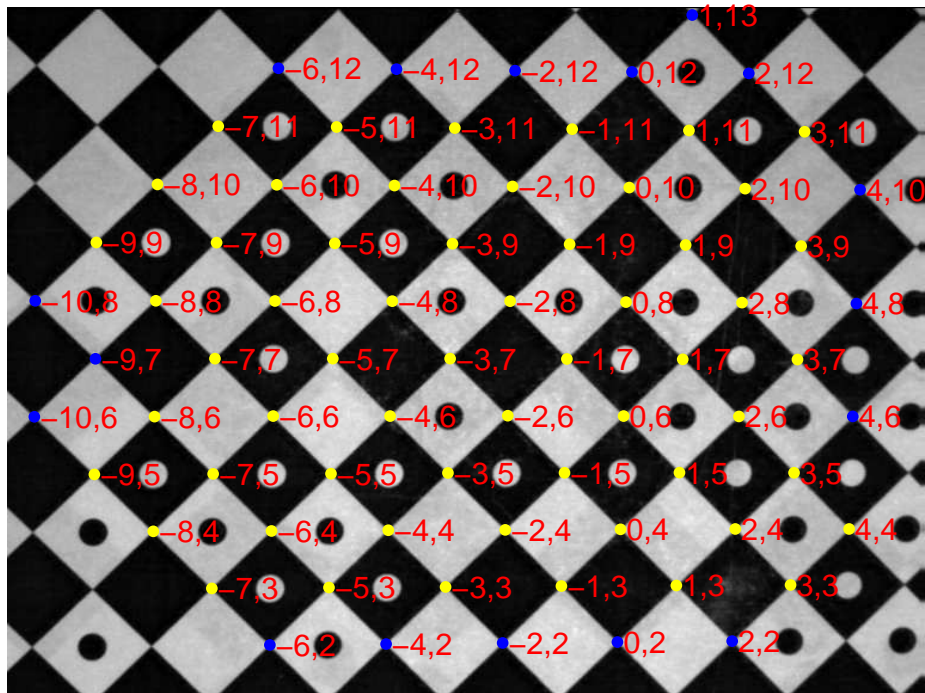

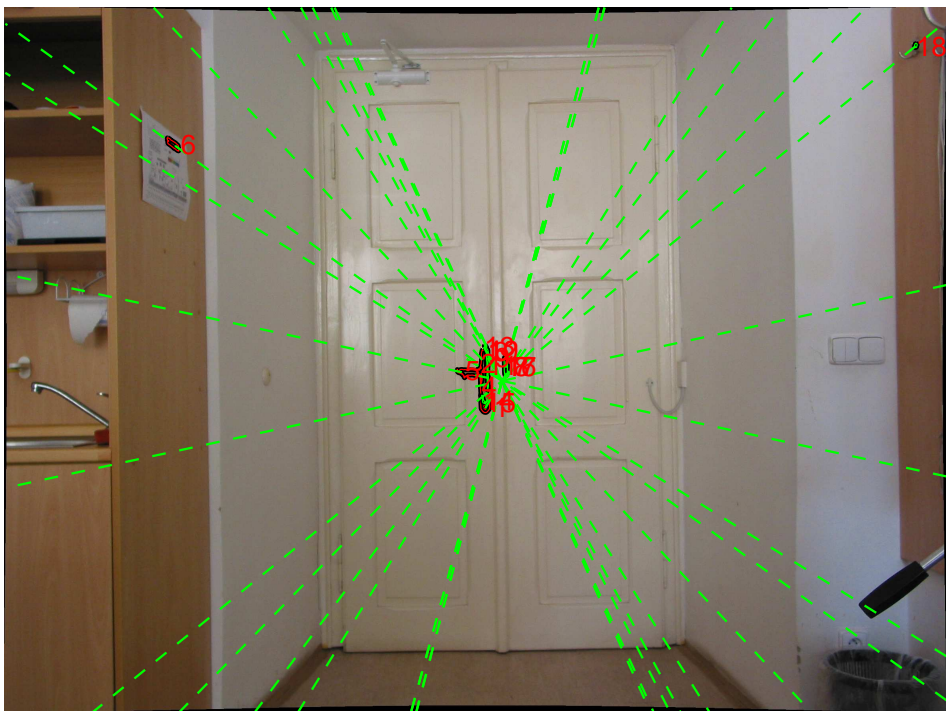

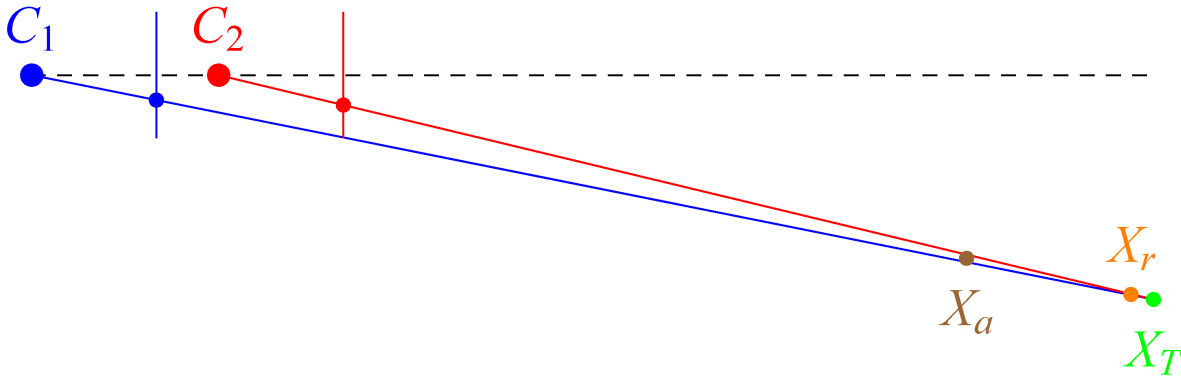

$C_1$

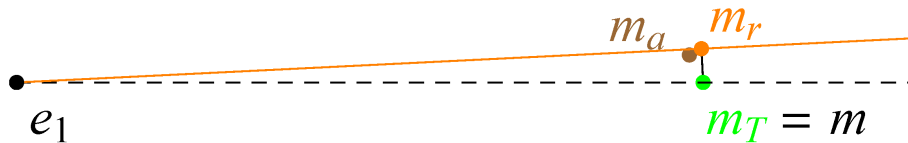



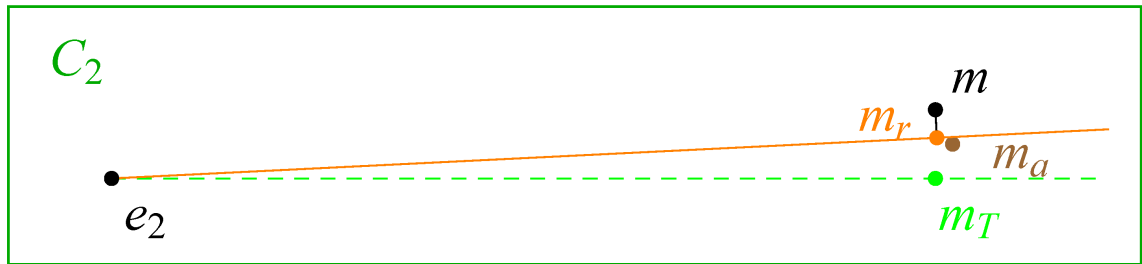

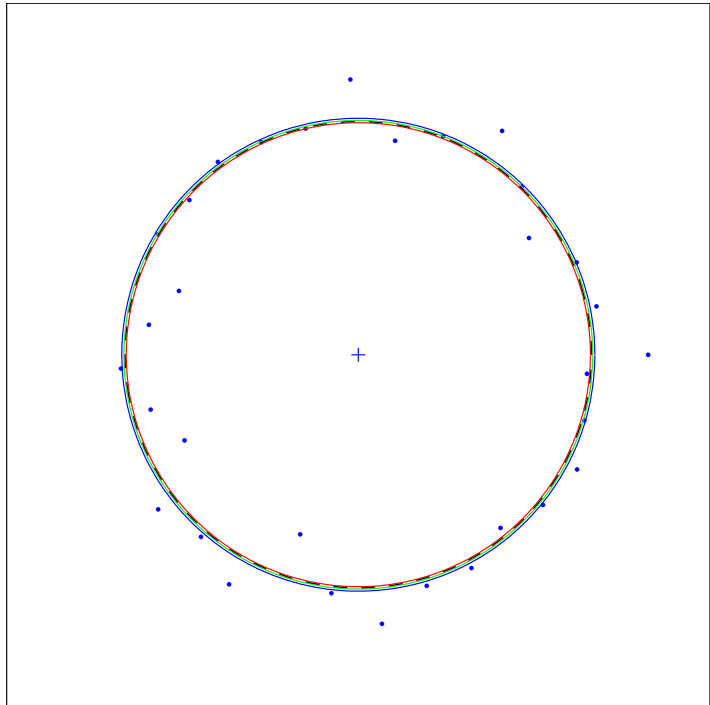

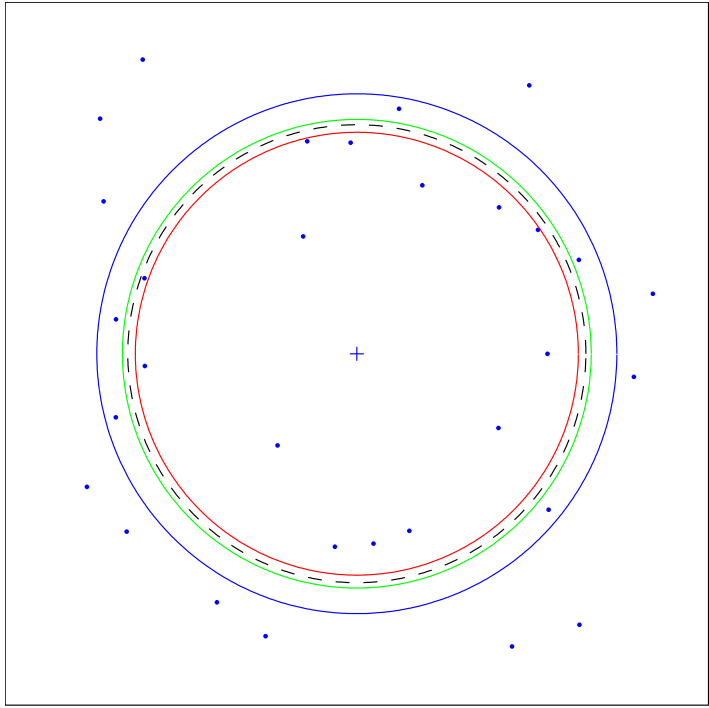

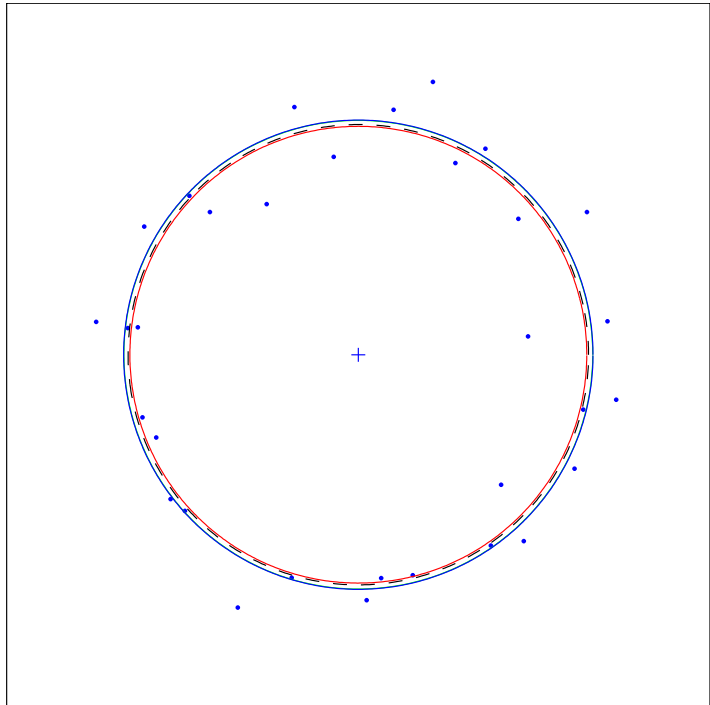

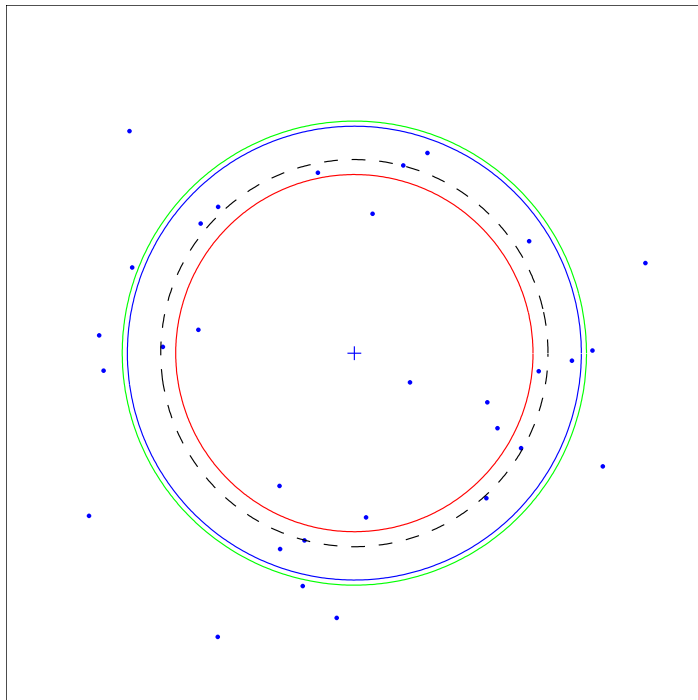

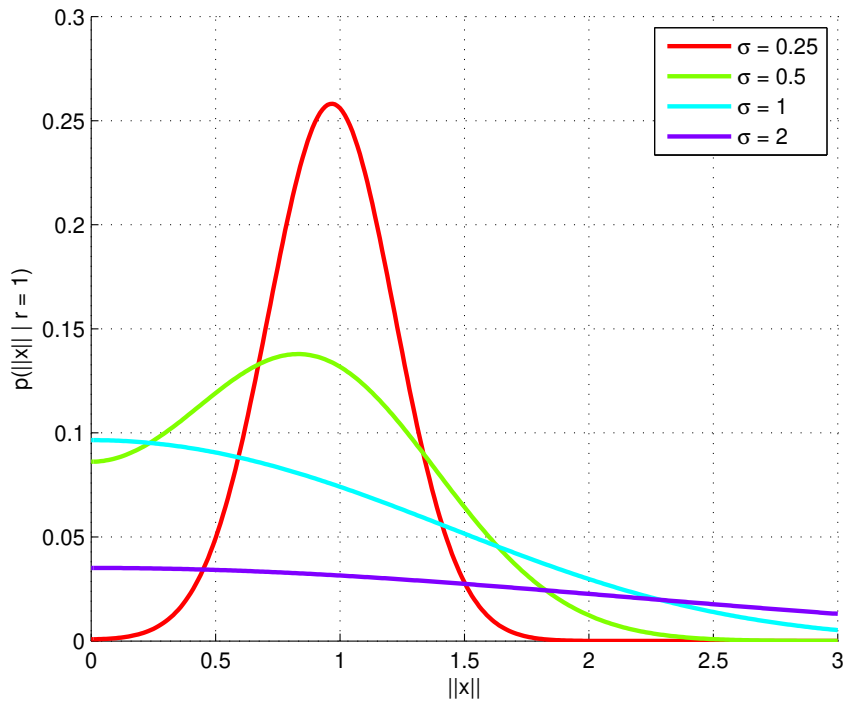

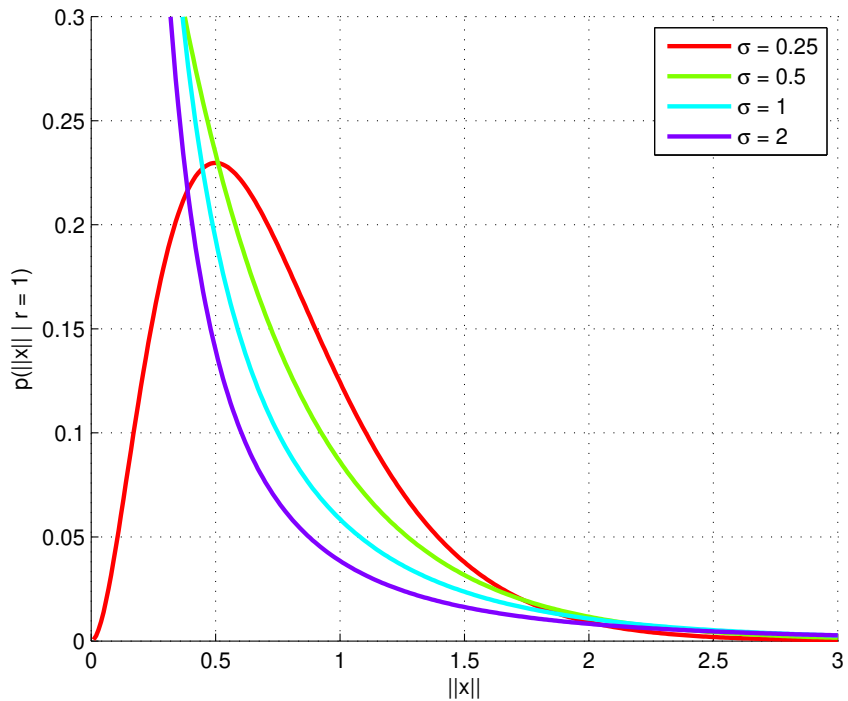

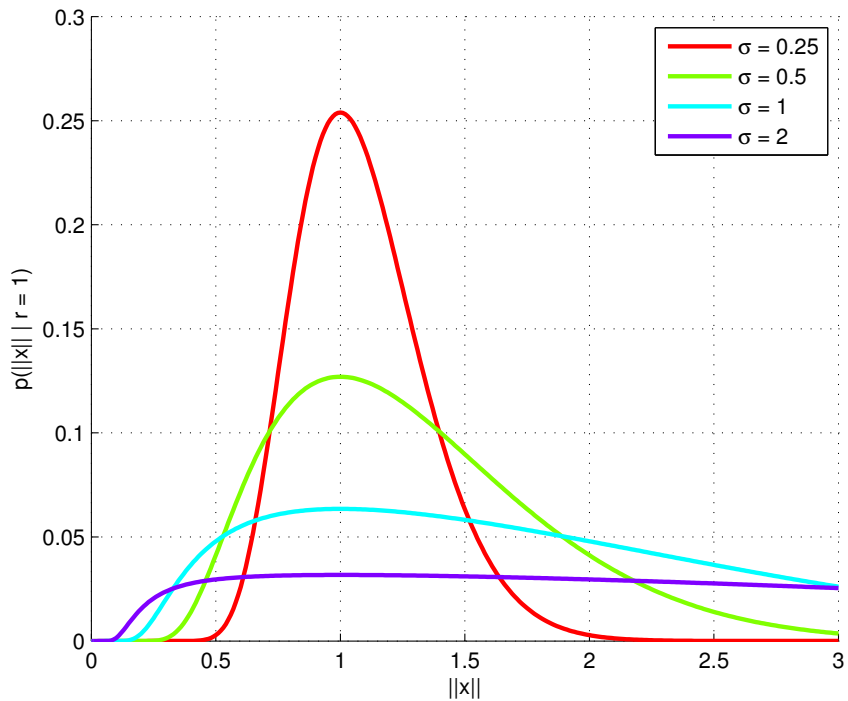



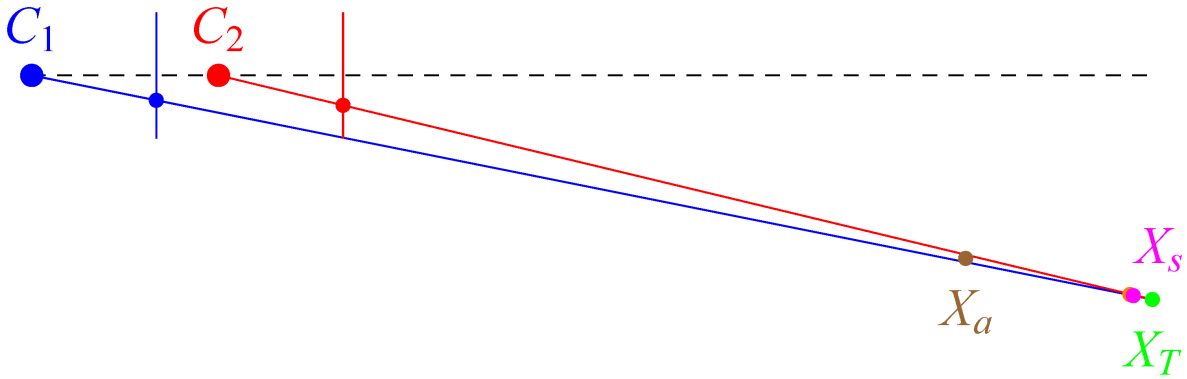

$C_1$

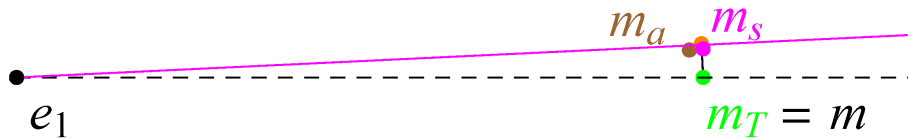

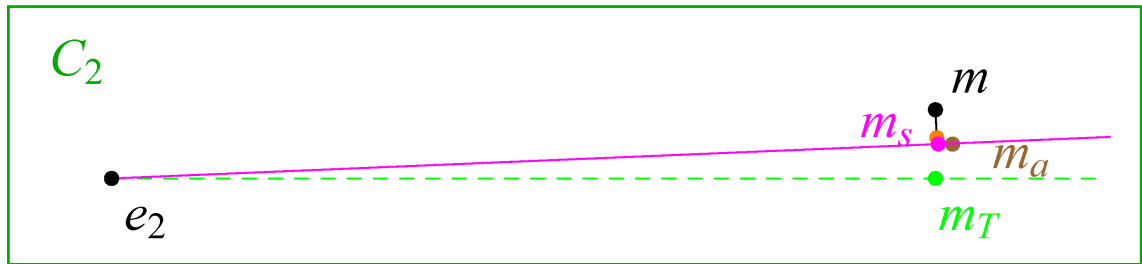







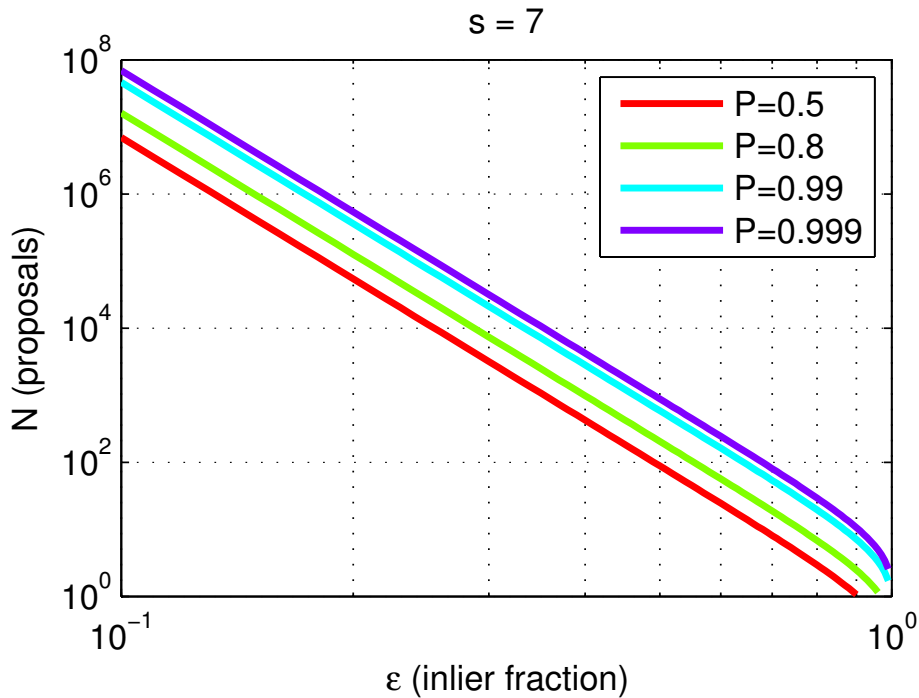

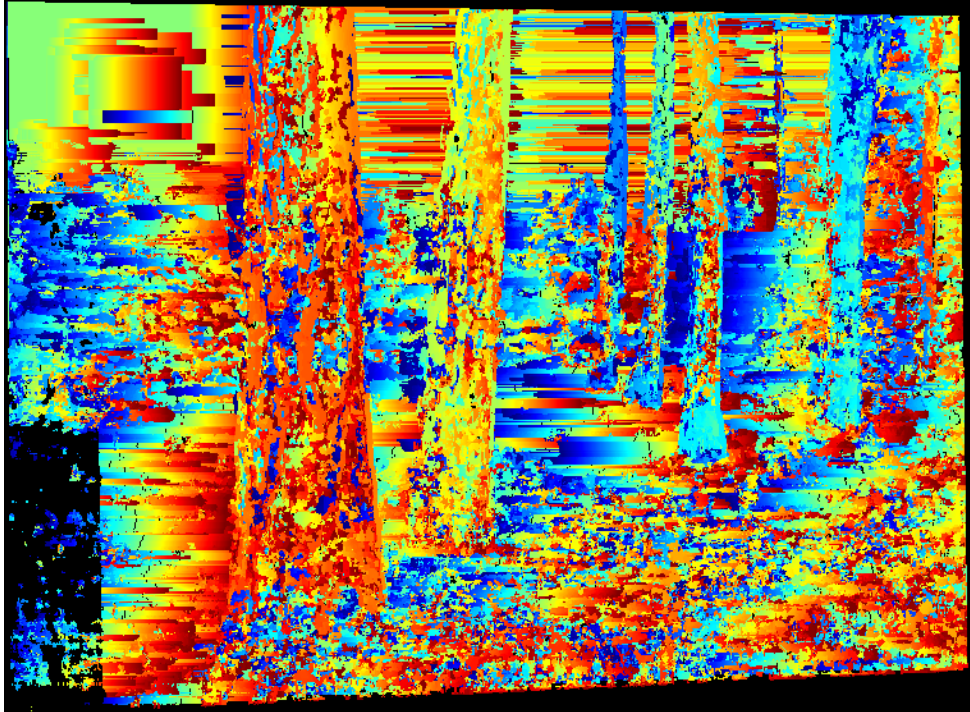



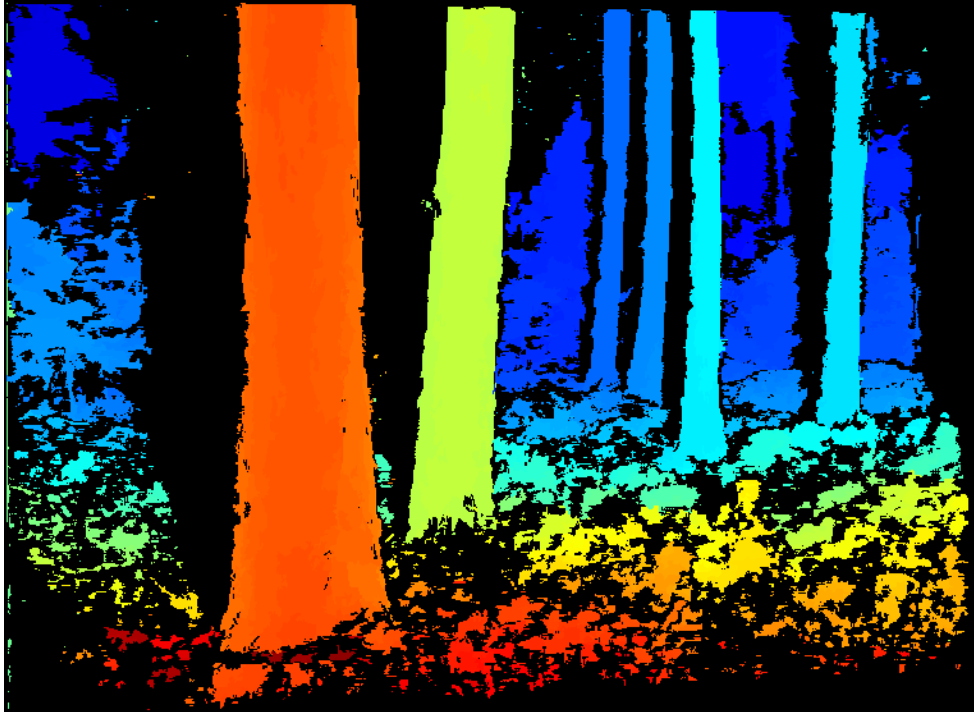

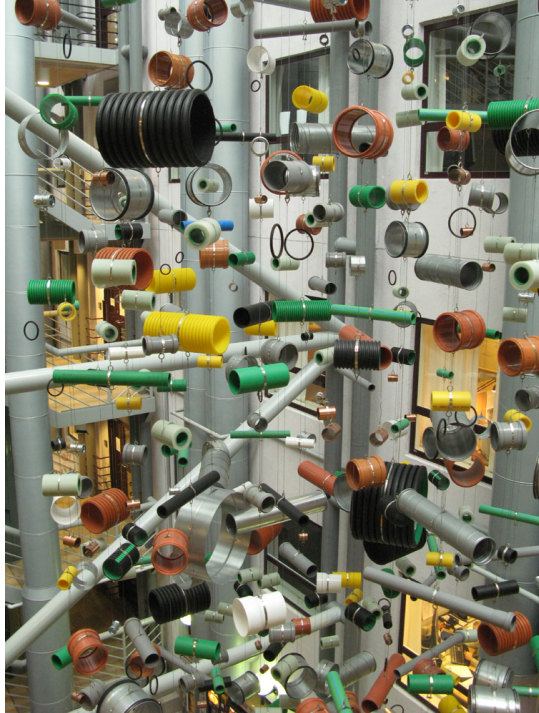



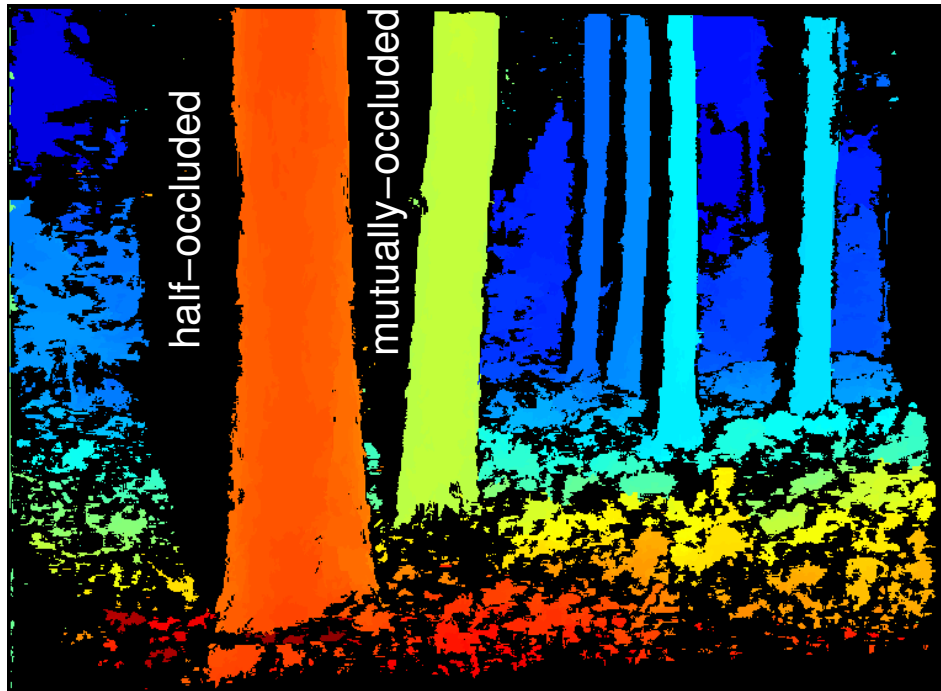

half-occluded

mutually-occluded

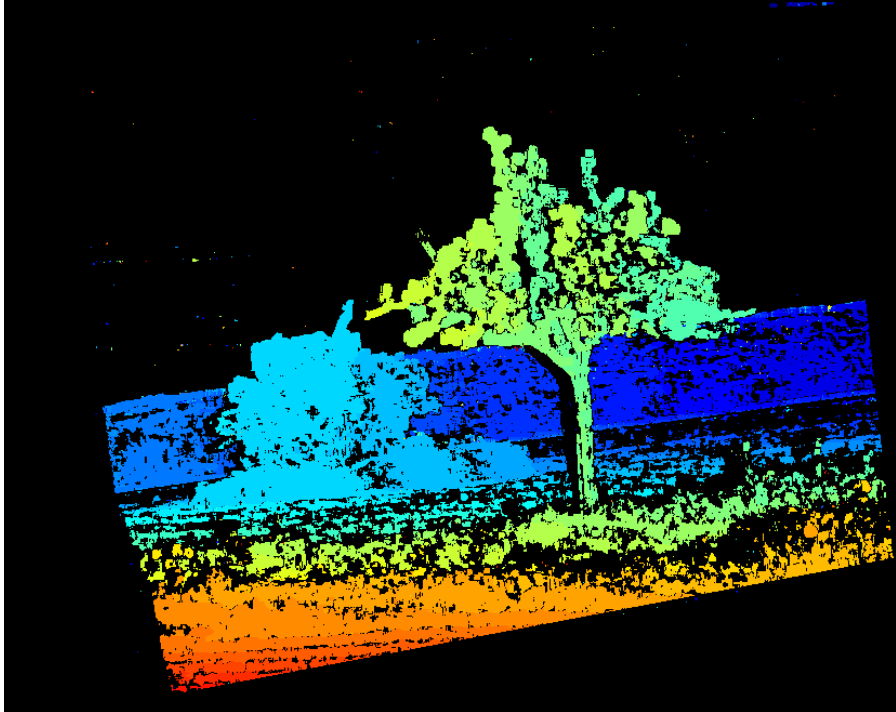

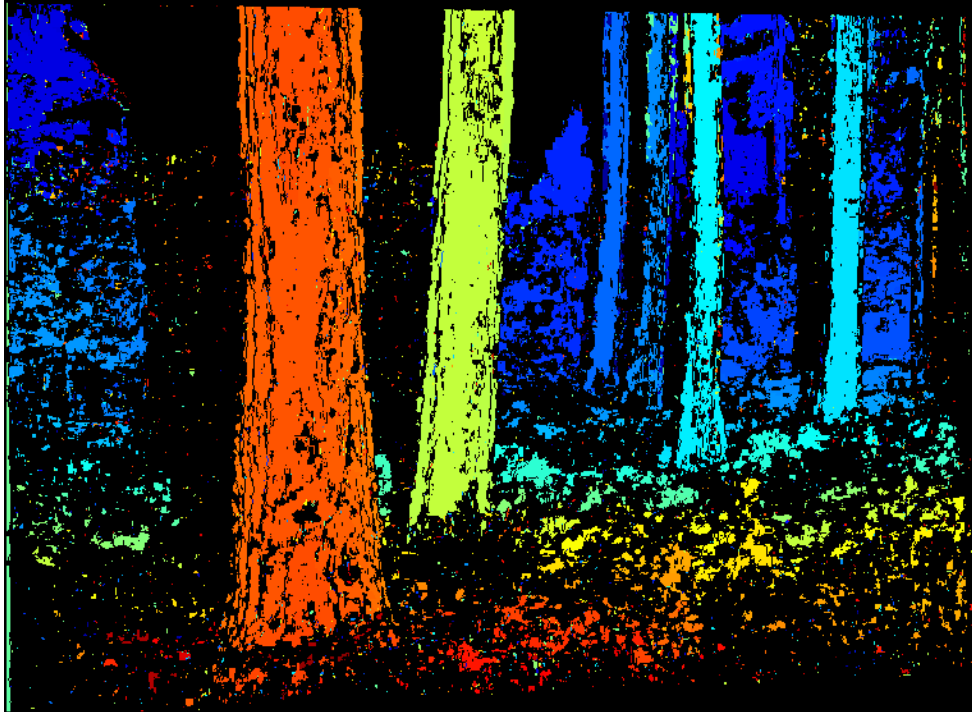



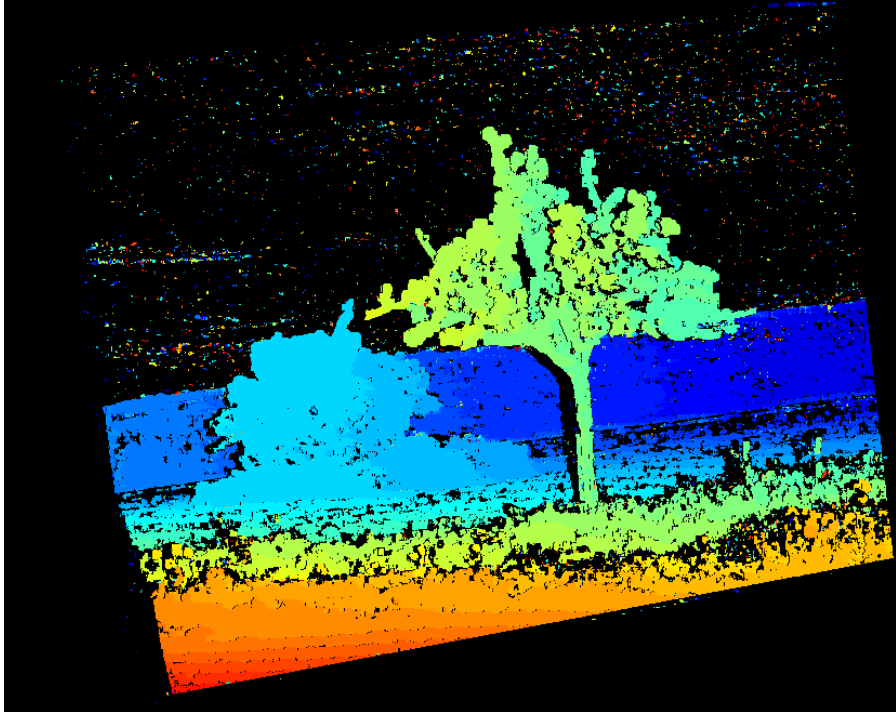



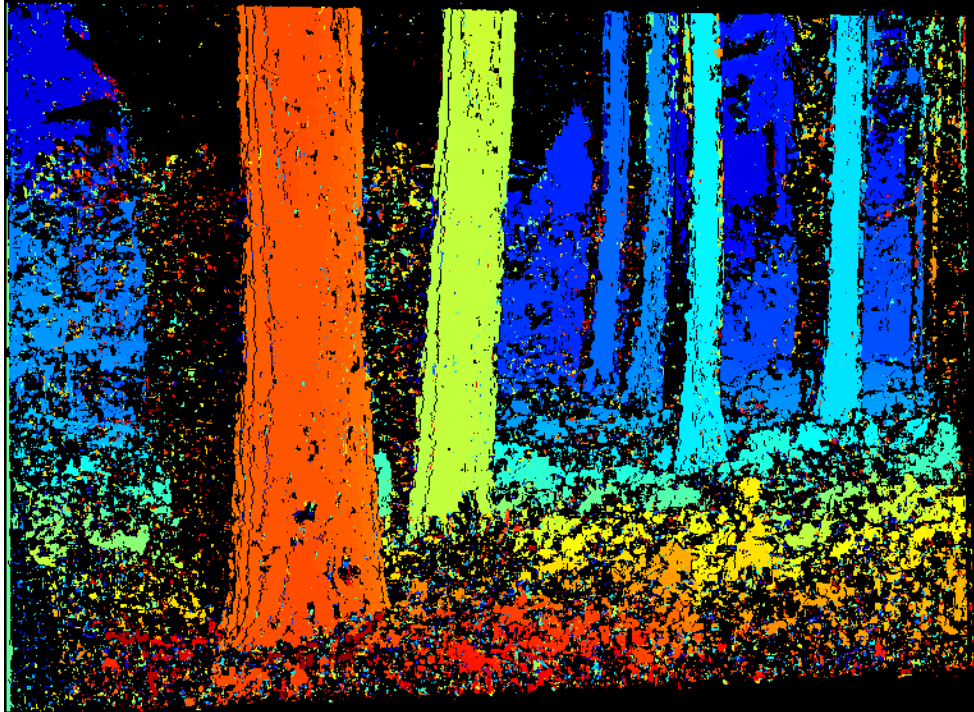





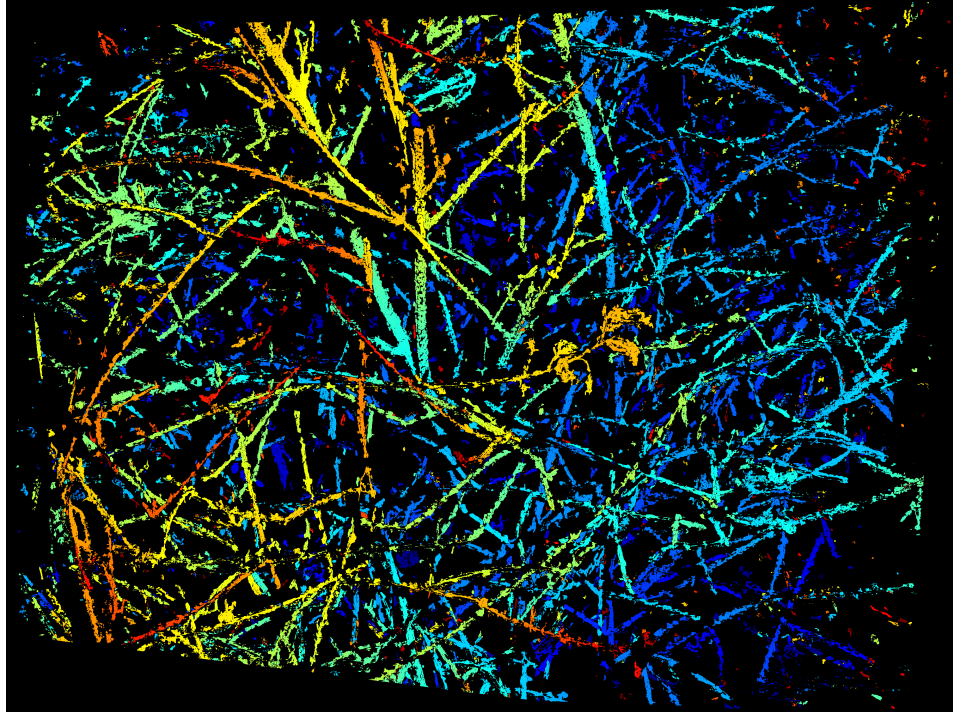





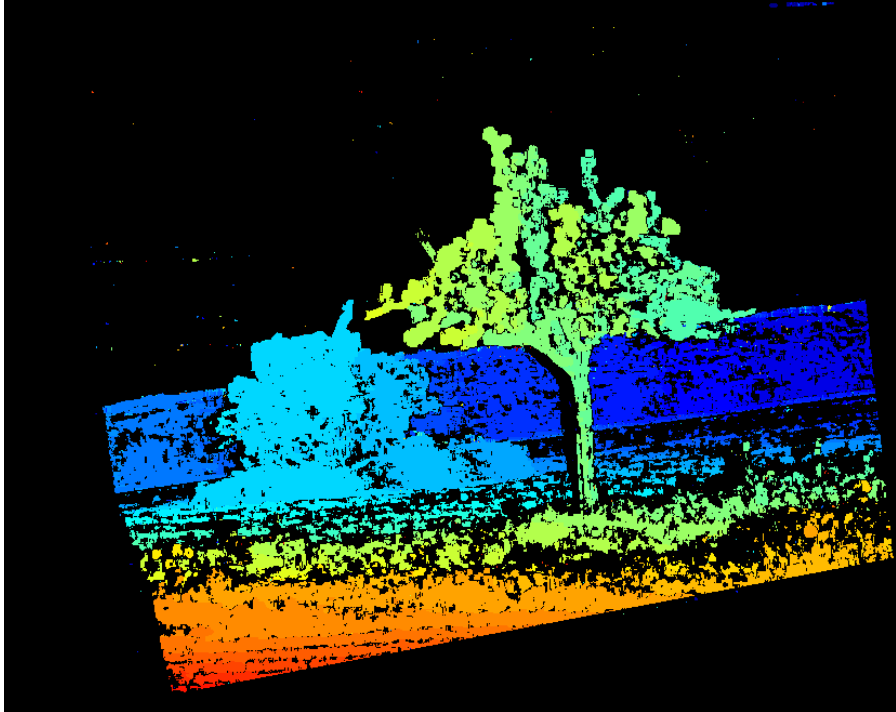

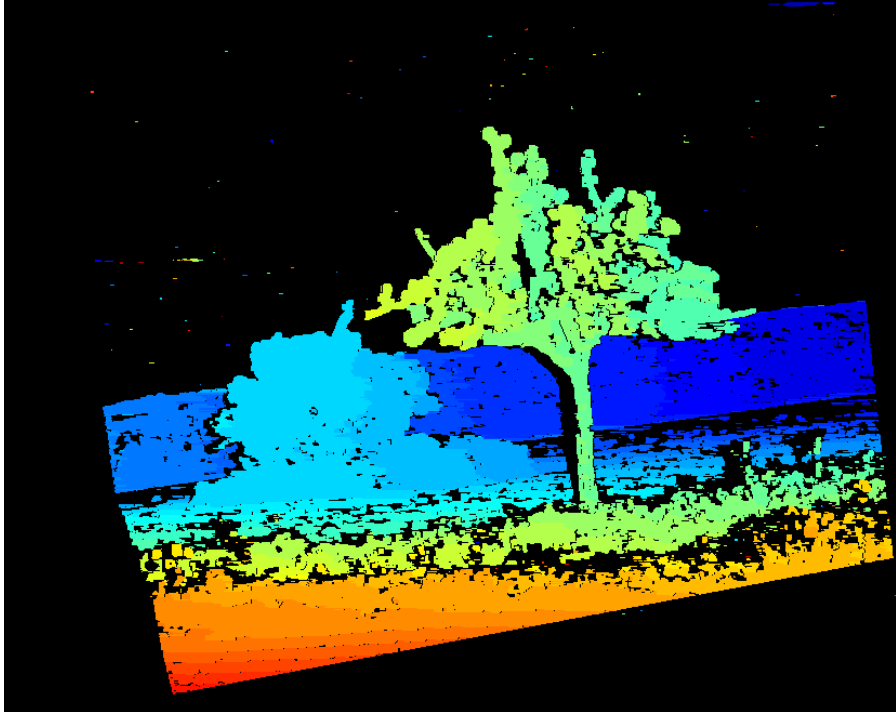



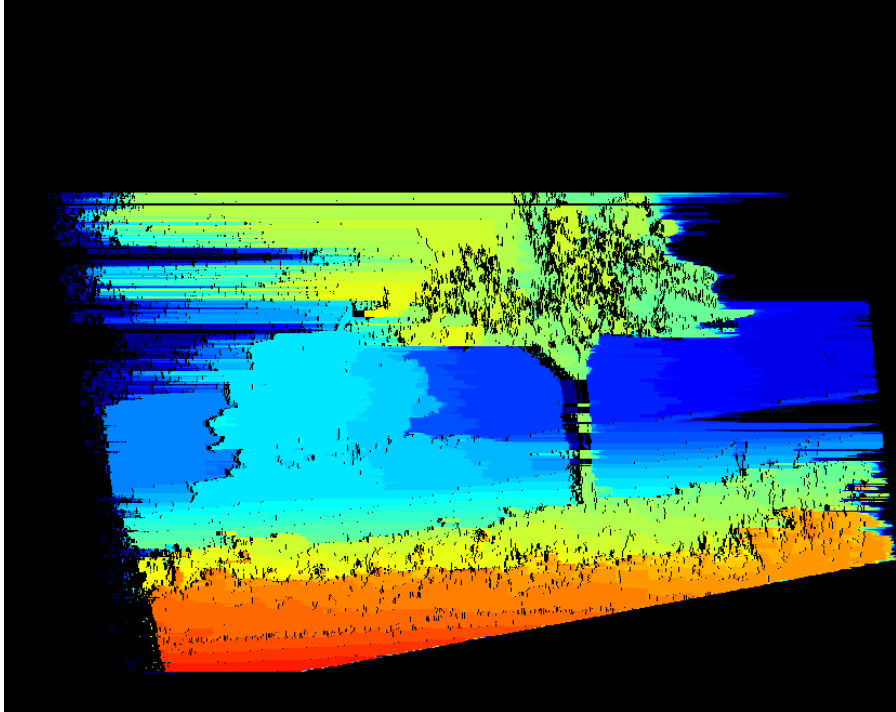

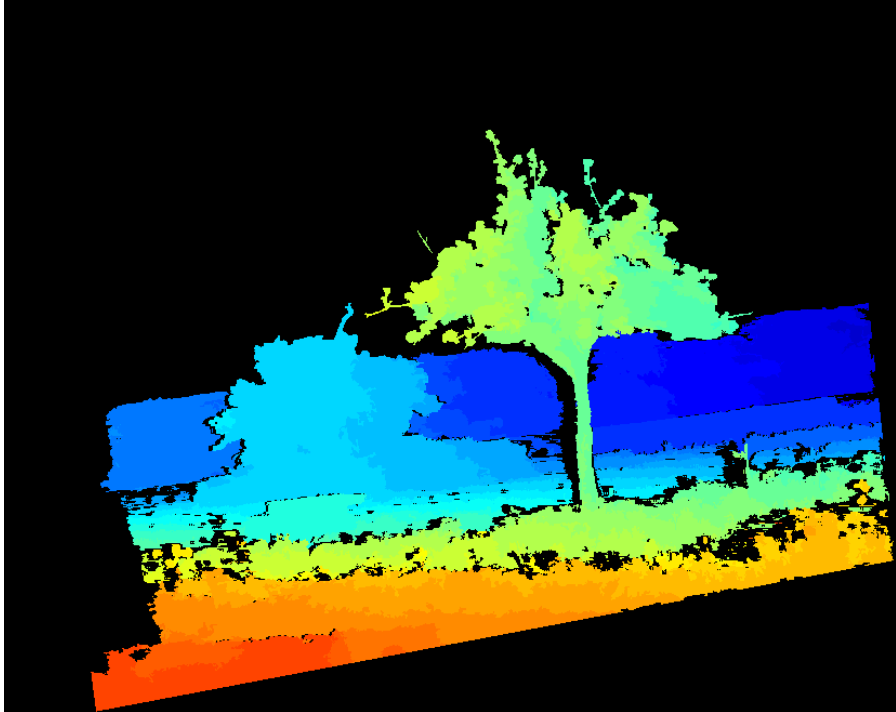





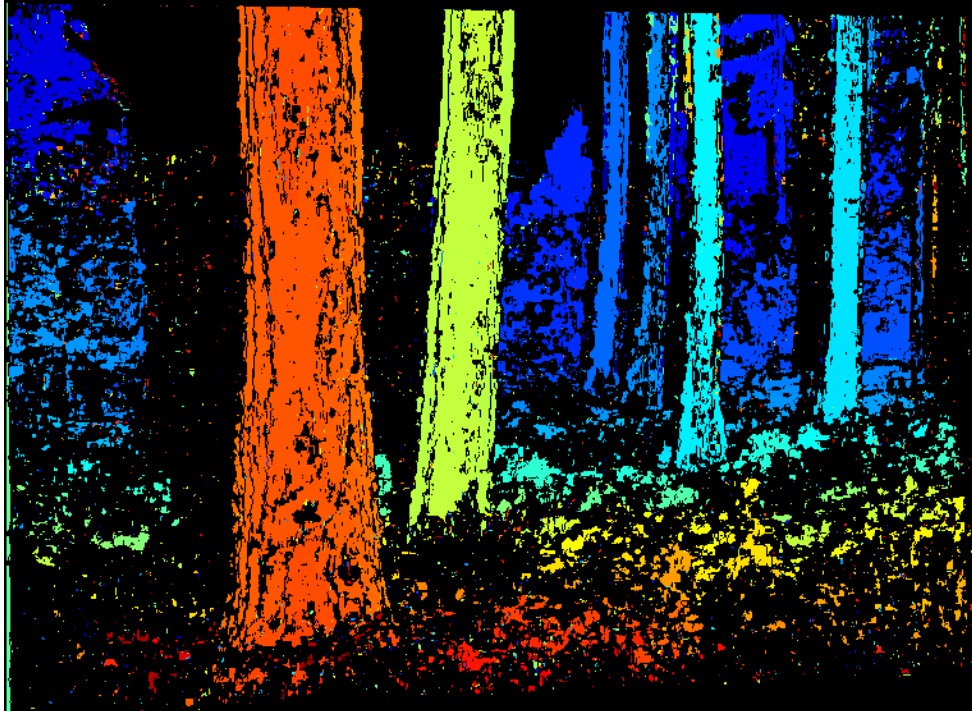

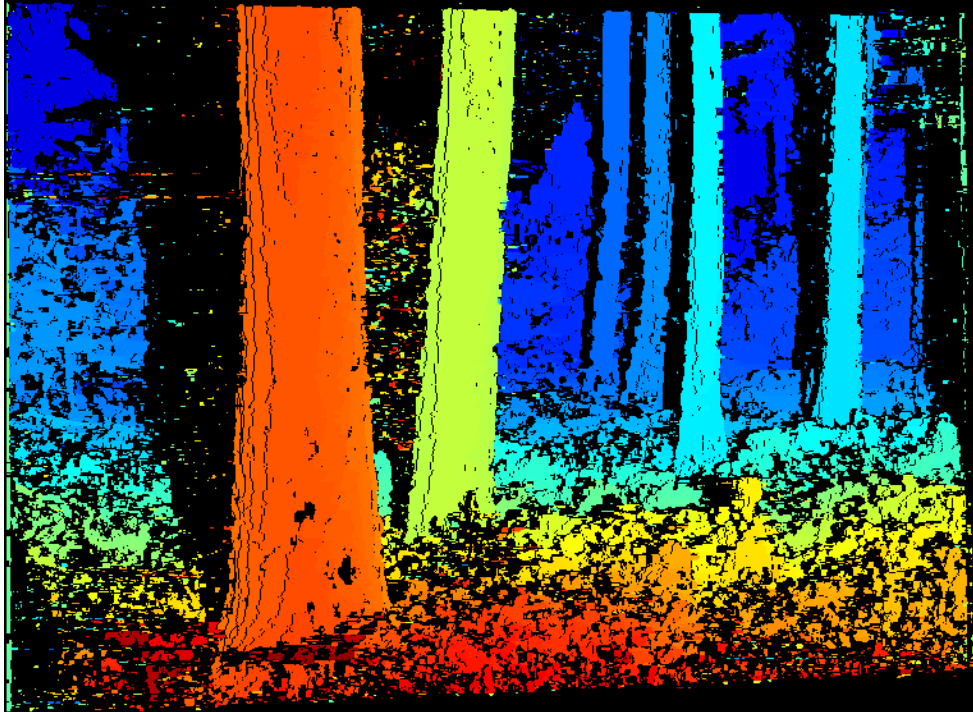

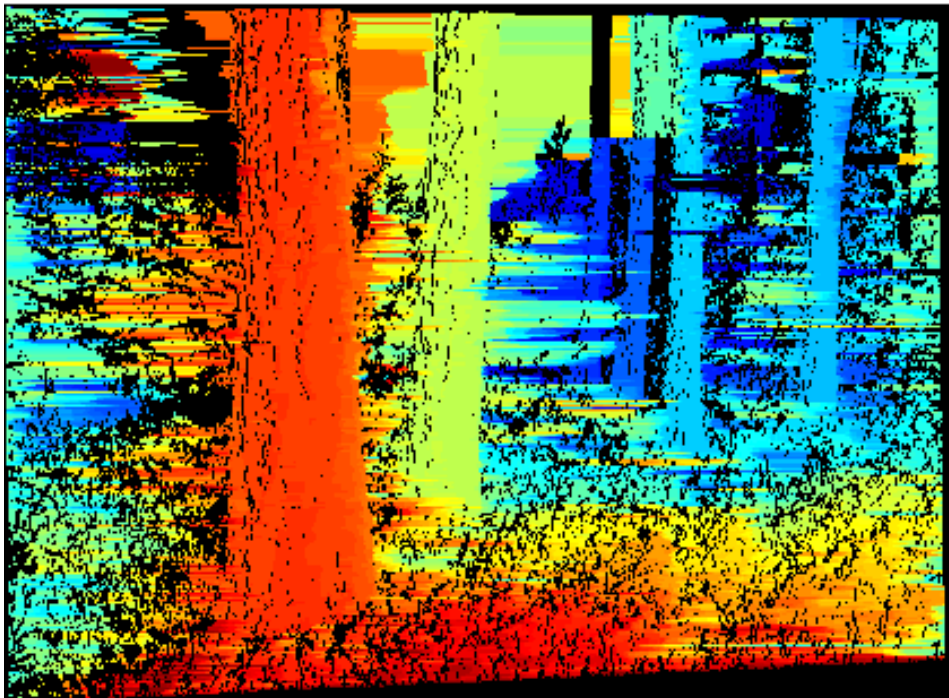

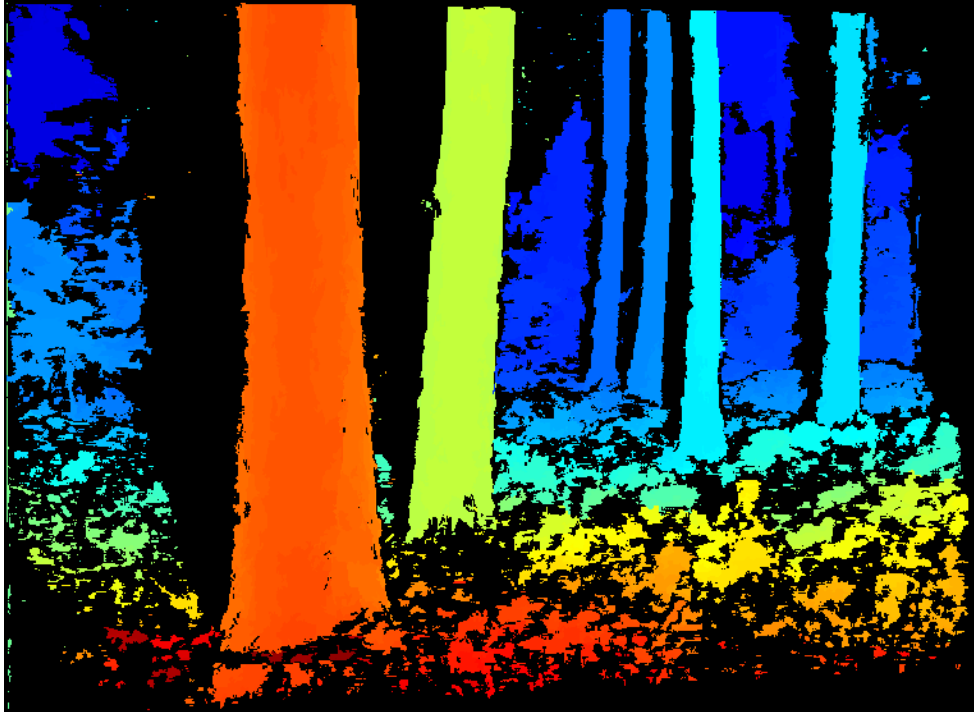



ROC curves and their average error rate bounds

