

# Computed tomography (CT)

Jiří Hozman, Jan Kybic

2005–2019

# Základní uspořádání systému CT

---



## CT history

- 1917** mathematical theory (Radon)
- 1956** tomography reconstruction in radioastronomy (Bracewell)
- 1963** CT reconstruction theory
- 1971** CT principles demonstrated (Hounsfield)
- 1972** first working CT for humans (EMI, London, Hounsfield)
- 1973** PET
- 1974** Ultrasound tomography
- 1982** SPECT
- 1985** Helical CT
- 1998** Multislice CT, 0.5 s/frame

# Johann Radon

(matematik)

---

\* 16.12.1887 Děčín, ČR  
† 25.5.1956 Vídeň, Rakousko

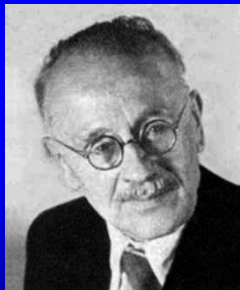

**1917** - "Über die Bestimmung von Funktionen durch ihre Integral-werte langs gewisser Mannigfaltigkeiten", *Berichte Sachsische Akademie der Wissenschaften. Leipzig, Math.-Phis. Kl.*, v.69, pp. 262-267. V této práci pan Radon matematicky vyřešil rekonstrukci prostorového obrazu na základě znalosti jeho projekcí.

# Sir Godfrey Newbold Hounsfield

---

1919-2004

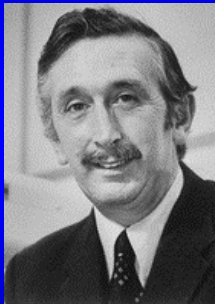

Nottinghamshire, samouk, nenavštěvoval univerzitu  
Nobelova cena 1979

*Sir Godfrey Hounsfield*  
*Nobel Prize in Medicine, 1979*

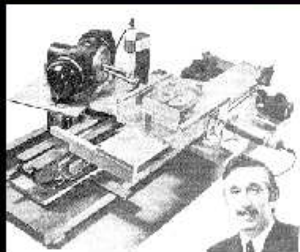

☒

Gamma Ray Source: 28,000  
measurements, 9 day collection,  
2.5 hour recon, 2hour display.

X-ray source reduced collection  
to 9 hours. Clinical model  
took 18 sec



☐

EMI-1, 1971:  
Atkinson Morley Hospital, England

# Allan M. Cormack

---

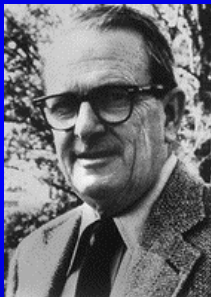

1924-1998, narozen v Johannesburgu

# Tomography modalities

- ▶ x-rays — CT
- ▶ gamma rays — PET, SPECT
- ▶ light — optical tomography
- ▶ RF waves — MRI
- ▶ DC — electric impedance tomography
- ▶ ultrasound — ultrasound tomography



# Základní princip CT

**CT vytváří obraz těla pacienta jako sérii tomografických sekcí (řezů). Každý řez je vytvořen matematickou rekonstrukcí předmětu ze znalosti průmětů (projekcí) předmětu do různých směrů.**

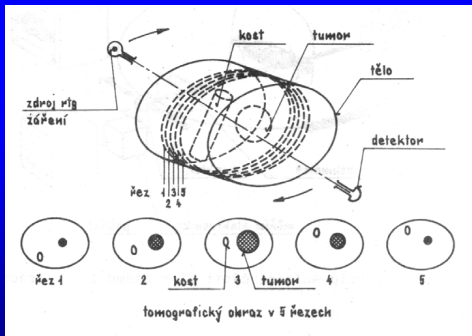

# Základní princip CT

Jednotlivé řezy objektu musí být rozděleny do sítě malých objemových elementů (voxels) se čtvercovou základnou a s konstantní hodnotou útlumu.

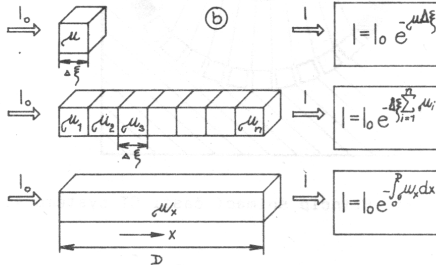
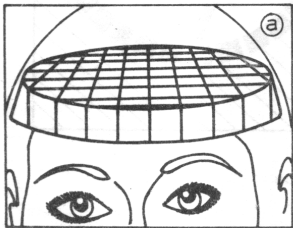

# Základní fyzikální princip CT

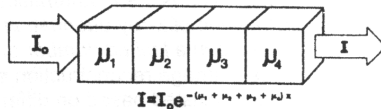
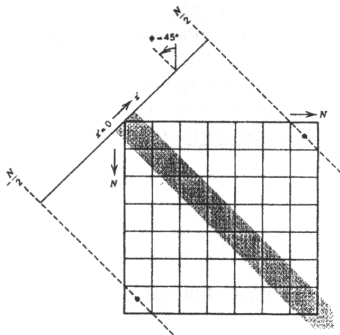

(a)

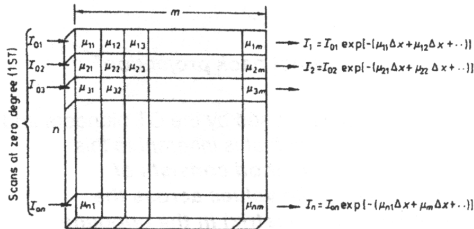

# CT systémy 1. generace

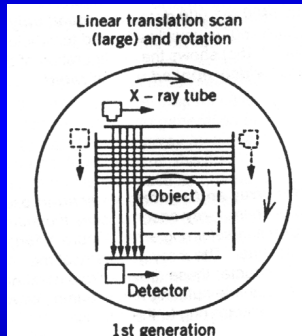
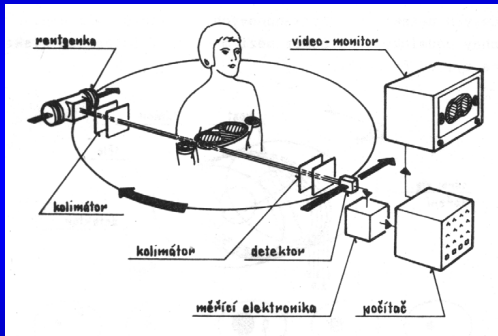

# CT systémy 2. generace

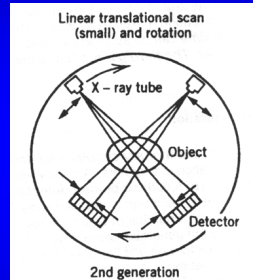
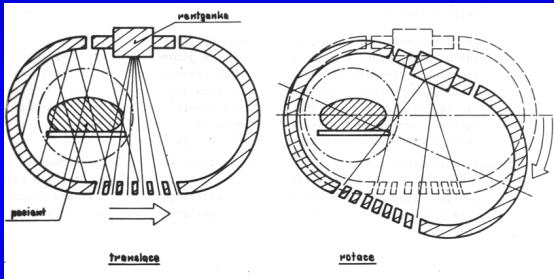

# CT systémy 3. generace

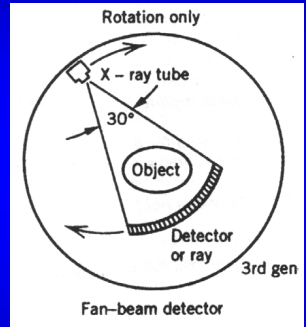
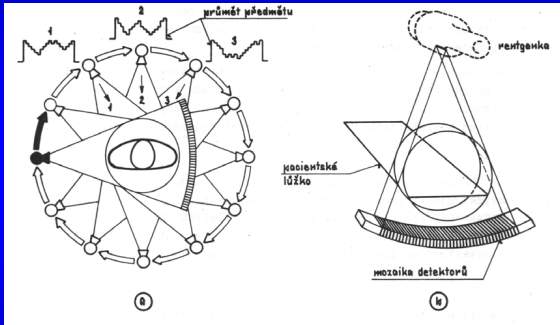

asi nejčastěji používané

# CT systémy 4. generace

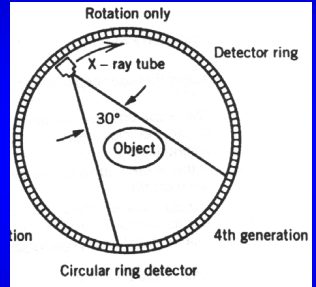
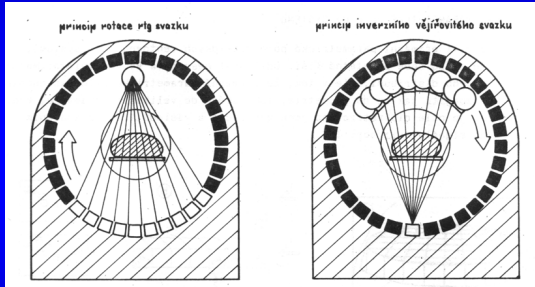

Rotuje jen zdroj, detektory stabilní

# „Utvrzování svazku“ (beam hardening)

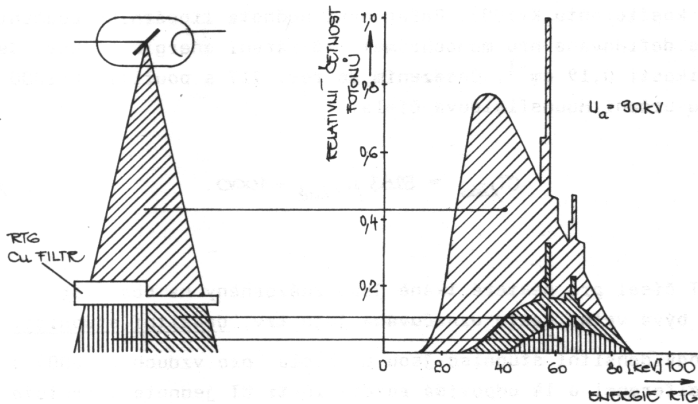



# „Utvrdování svazku“ (beam hardening)

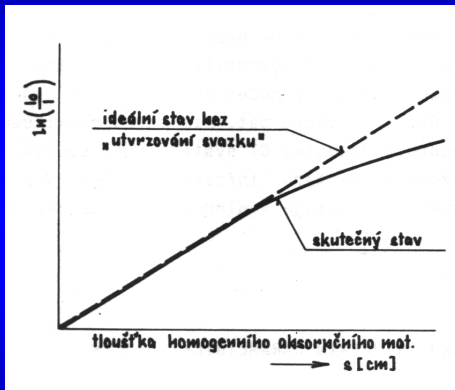

# CT číslo - Haunsfieldovo číslo (HU)

---

Je vyjádřením kvantitativního hodnocení absorpčních vlastností tkáně.

$$CT = K \cdot \frac{\mu_{\text{tkáň}} - \mu_{\text{vody}}}{\mu_{\text{vody}}} \quad K = 1000$$
$$\mu_{\text{vody}} = 0,19 \text{ cm}^{-1}$$

Měřeno monochromatickým zářením 73 keV.

$$CT = 5263 \mu_{\text{tkáň}} - 1000$$

stupnice CT čísel = denzitní stupnice

rozsah od -1000 až zhruba +1000, pro vzduch -1000,  
pro vodu 0

# CT číslo - Haunsfieldovo číslo (HU)

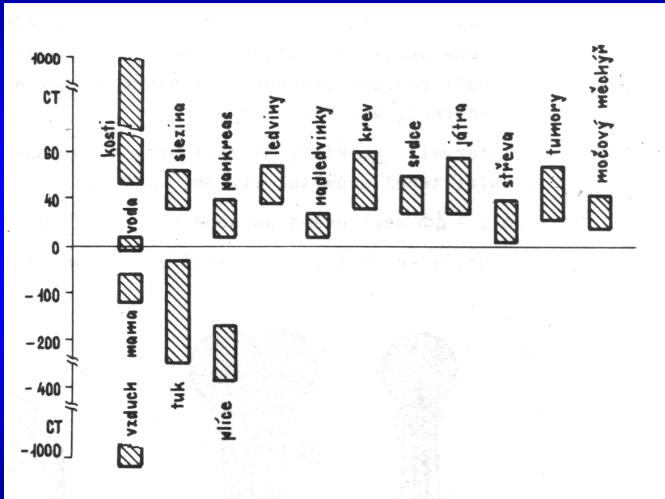

# Generace, zpracování a detekce radičního signálu CT systémů

## CT systémy 2. generace (několik detektorů)

- pomalé a rychlé systémy
- sendvičový a lamelový kolimátor

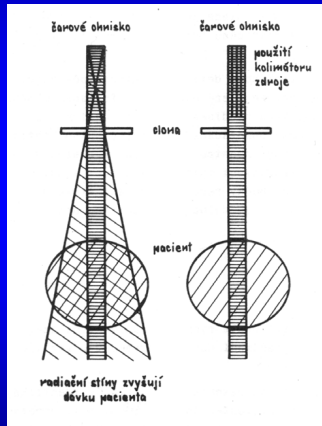

# Generace, zpracování a detekce radiačního signálu CT systémů

## Detektory

scintilační detektor (krystal)  
+ fotonásobič

ionizační komory plněné  
plynem (xenon)

scintilační detektor (krystal)  
+ fotodioda (fototranzistor)

Flat-panel detector (FPD)

Thin-film transistor (TFT) array

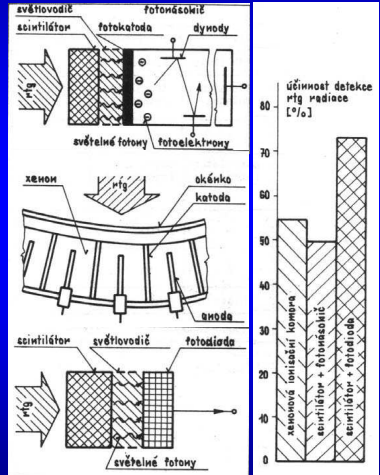

# Základní principy rekonstrukce obrazu

$O(\xi, \eta)$  denzitní funkce =  
předmětová funkce

lin. součinitel  
zeslabení

$(\xi, \eta)$  původní souř.

$\Phi$  snímací úhel

$\xi'$  rotovaná souř.

$\eta'$  rotovaná souř.

$p(\xi', \Phi)$  paprskový součet či průmět

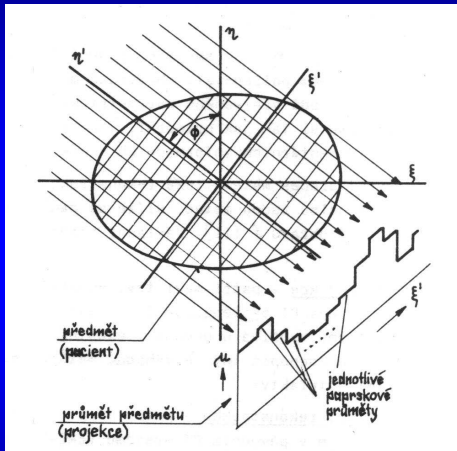

## Základní principy rekonstrukce obrazu

$$p(\xi', \Phi) = \int o(\xi, \eta) d\eta' \quad I = I_0 \exp\left[-\int (\xi, \eta) d\eta\right]$$

$$o(\xi, \eta) \approx (\xi, \eta)$$

$$p(\xi', \Phi) = -\ln \frac{I_0}{I}$$

$$\xi' = \xi \cdot \cos \Phi + \eta \cdot \sin \Phi$$

$$\xi = \xi' \cdot \cos \Phi - \eta \cdot \sin \Phi$$

$$\eta' = -\xi \cdot \sin \Phi + \eta \cdot \cos \Phi$$

$$\eta = \xi' \cdot \sin \Phi + \eta \cdot \cos \Phi$$

# Radon transform

Projection in polar coordinates:

$$P_\varphi(\xi') = \mathcal{R}[o(\xi, \eta)]$$

$$P_\varphi(\xi') = \int_L o(\xi, \eta) dl$$

along the line  $L$  defined by  $\varphi$  a  $\xi'$ :

$$\xi' = \xi \cos \varphi + \eta \sin \varphi$$

Equivalently

$$P_\varphi(\xi') = \int o(\xi' \cos \varphi - \eta' \sin \varphi, \xi' \sin \varphi + \eta' \cos \varphi) d\eta'$$



# Radonova transformace

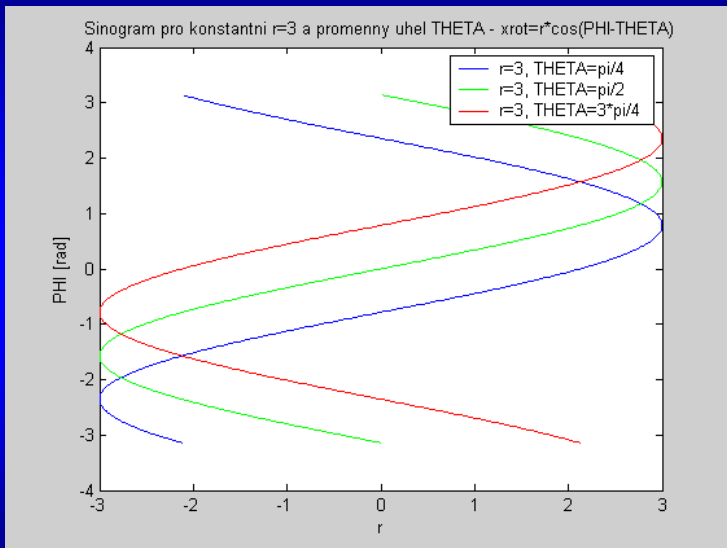

# Radonova transformace

Sinogram pro konstantní uhel  $\text{THETA}=\pi/4$  a proměnný polomer  $r$  -  $x_{\text{rot}}=r*\cos(\text{PHI}-\text{THETA})$

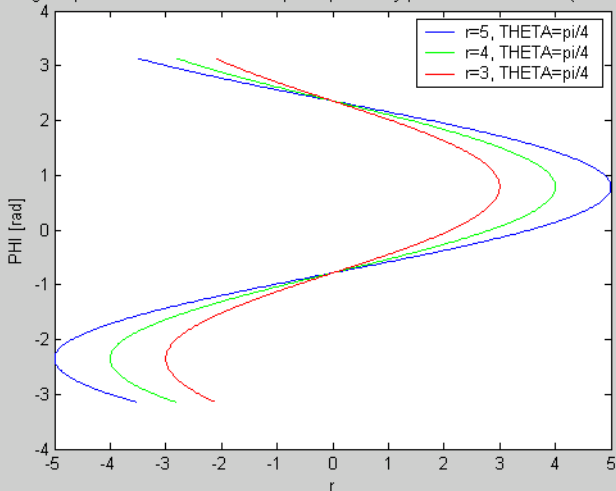

# Radonova transformace

---

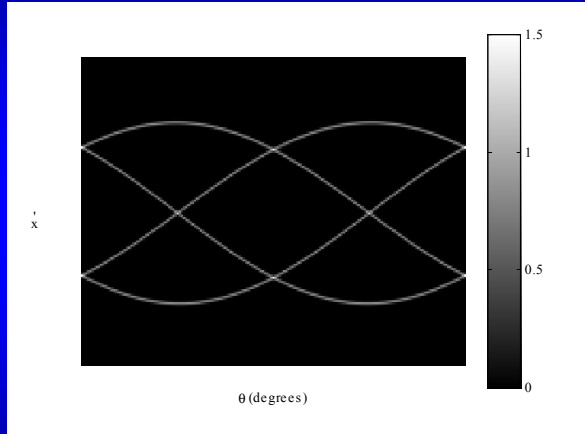
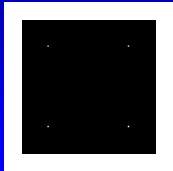

# Radonova transformace

---

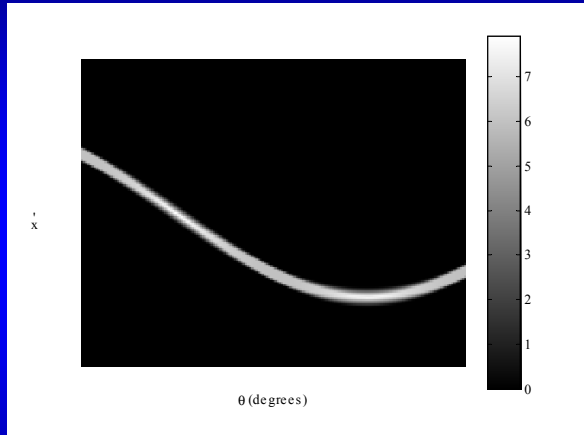
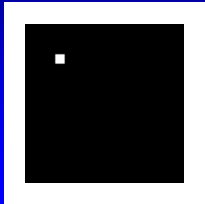

# Radonova transformace

---

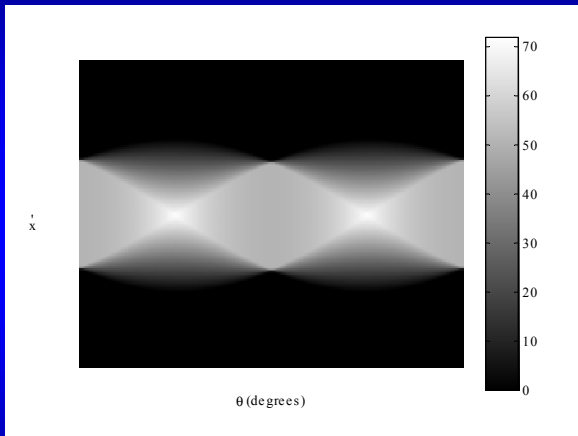
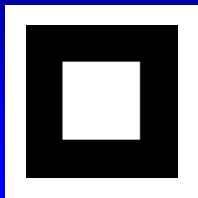

# Radonova transformace

---

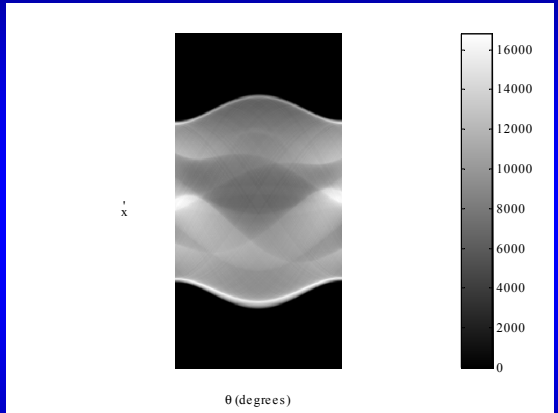

Shepp-Logan fantom

# Radonova transformace

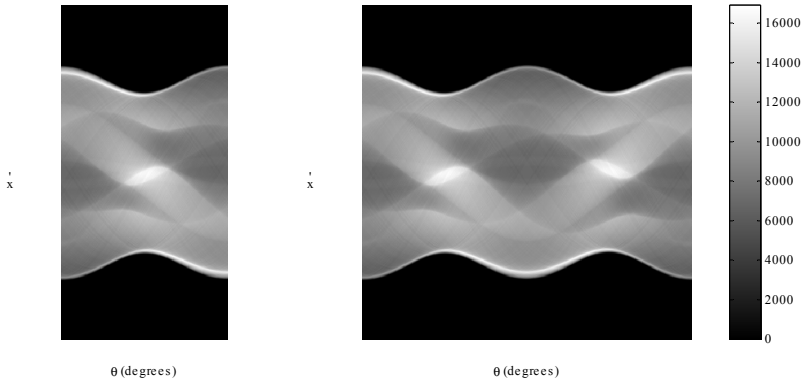

Periodicity RT vůči úhlu

# Reconstruction methods

- ▶ *Backprojection*
- ▶ *Fourier reconstruction*
- ▶ Filtered backprojection
- ▶ Algebraic reconstruction (iterative)



# Přímá zpětná projekce

$$i(x,y) = \sum_{j=1}^m p(\xi', \Phi_j) \Delta\Phi$$

$\Phi_j$  j-tý projekční úhel

$\Delta\Phi$  úhlový přírůstek mezi projekcemi

$m$  počet projekcí

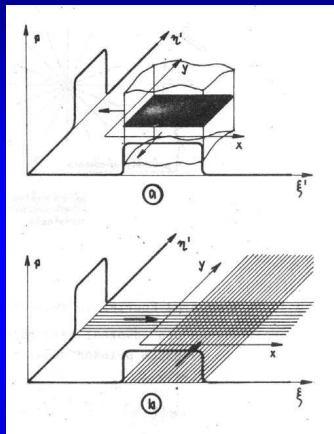

$$i(x,y) = \sum_{j=1}^m p((x \cdot \cos \Phi_j + y \cdot \sin \Phi_j), \Phi_j) \Delta\Phi$$

# Přímá zpětná projekce - hvězdicový artefakt

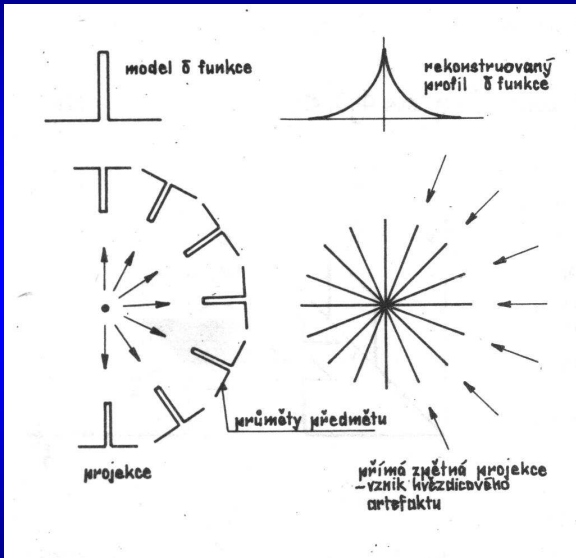

# Central slice theorem

Projection Theorem, Věta o centrálním řezu)

$$P_{\varphi}(\xi') = \int o(\xi' \cos \varphi - \eta' \sin \varphi, \xi' \sin \varphi + \eta' \cos \varphi) d\eta'$$

Fourier transform of the Radon transform by  $\xi'$ :

$$\begin{aligned} \mathcal{F} \{ \mathcal{R} [o(\xi, \eta)] \} &= \mathcal{F} \{ P_{\varphi}(\xi') \} = \hat{P}_{\varphi}(\omega) = \int P_{\varphi}(\xi') e^{-2\pi j \omega \xi'} d\xi' \\ &= \iint o(\xi' \cos \varphi - \eta' \sin \varphi, \xi' \sin \varphi + \eta' \cos \varphi) e^{-2\pi j \omega \xi'} d\xi' d\eta' \end{aligned}$$

Substitution  $(\xi', \eta') \rightarrow (\xi, \eta)$ :

$$\hat{P}_{\varphi}(\omega) = \int o(\xi, \eta) e^{-2\pi j \omega (\xi \cos \varphi + \eta \sin \varphi)} d\xi d\eta$$

## Central slice theorem

$$\hat{P}_\varphi(\omega) = \int o(\xi, \eta) e^{-2\pi j \omega (\xi \cos \varphi + \eta \sin \varphi)} d\xi d\eta$$

Denote  $u = \omega \cos \varphi$     $v = \omega \sin \varphi$

$$\hat{P}(u, v) = \int o(\xi, \eta) e^{-2\pi j (\xi u + \eta v)} d\xi d\eta$$

and therefore

$$\hat{P}(u, v) = \mathcal{F} \{o(\xi, \eta)\}$$

$$\hat{P}_\varphi(\omega) = \mathcal{F} \{o(\xi, \eta)\} (\omega \cos \varphi, \omega \sin \varphi) = \hat{o}(\omega \cos \varphi, \omega \sin \varphi)$$

## Central slice theorem

$$\hat{P}(u, v) = \mathcal{F} \{o(\xi, \eta)\}$$

$$\hat{P}_\varphi(\omega) = \mathcal{F} \{o(\xi, \eta)\} (\omega \cos \varphi, \omega \sin \varphi) = \hat{o}(\omega \cos \varphi, \omega \sin \varphi)$$

Slice of the 2D Fourier transform of the image  $o$  at angle  $\varphi$  is the 1D Fourier transform of the projection  $P_\varphi$  of the same image  $o$ .

# Analytická rekonstrukce - 2D FT

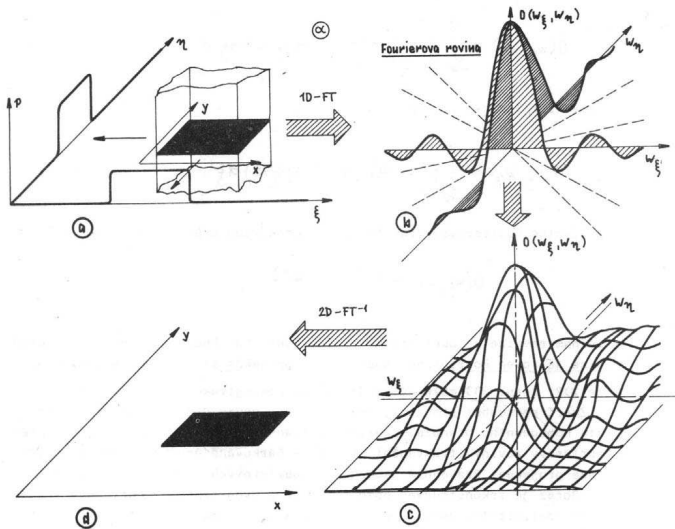

# Analytická rekonstrukce - 2D FT

(3)

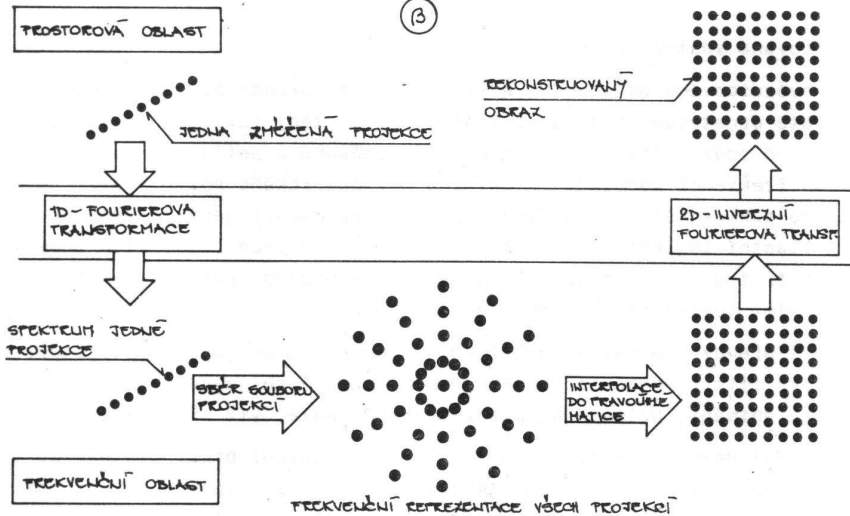

## Inverse Radonova transform

From the Fourier slice theorem:

$$\hat{P}(u, v) = \mathcal{F} \{o(\xi, \eta)\}$$

$$o(\xi, \eta) = \mathcal{F}^{-1} \{ \hat{P}(u, v) \} = \int_{-\infty}^{\infty} \int_{-\infty}^{\infty} \hat{P}(u, v) e^{2\pi j(\xi u + \eta v)} du dv$$

Polar coordinates  $u = \omega \cos \varphi$ ,  $v = \omega \sin \varphi$ :

$$o(\xi, \eta) = \int_0^{\pi} \int_{-\infty}^{\infty} \hat{P}_{\varphi}(\omega) e^{2\pi j\omega(\xi \cos \varphi + \eta \sin \varphi)} |\omega| d\omega d\varphi$$

where  $|\omega|$  is the Jacobian (determinant).



## Inverse Radonova transform

$$o(\xi, \eta) = \int_0^{\pi} \int_{-\infty}^{\infty} \hat{P}_{\varphi}(\omega) e^{2\pi j\omega(\xi \cos \varphi + \eta \sin \varphi)} |\omega| d\omega d\varphi$$

can be written as

$$o(\xi, \eta) = \int_0^{\pi} Q_{\varphi}(\underbrace{\xi \cos \varphi + \eta \sin \varphi}_{\xi'}) d\varphi$$

$$Q_{\varphi}(\xi') = \int_{-\infty}^{\infty} \hat{P}_{\varphi}(\omega) e^{2\pi j\omega\xi'} |\omega| d\omega$$

where  $Q_{\varphi}(\xi')$  is a modified projection

## Inverse Radonova transform

$$o(\xi, \eta) = \int_0^{\pi} Q_{\varphi}(\xi') d\varphi$$

$$Q_{\varphi}(\xi') = \int_{-\infty}^{\infty} \hat{P}_{\varphi}(\omega) e^{2\pi j\omega\xi'} |\omega| d\omega$$

$$Q_{\varphi}(\xi') = \mathcal{F}^{-1} \{ |\omega| \hat{P}_{\varphi}(\omega) \} = \mathcal{F}^{-1} \{ |\omega| \} * P_{\varphi}(\xi')$$

defining the exact inverse Radon transform

$$P_{\varphi}(\xi') = \mathcal{R}[o(\xi, \eta)]$$

$$o(\xi, \eta) = \mathcal{R}^{-1}[P_{\varphi}(\xi')]$$

# Filtered backprojection

Filtrovaná zpětná projekce

- ▶ Filter all projections  $P_\varphi(\xi')$  for all  $\varphi$ , get modified projections  $Q_\varphi(\xi')$
- ▶ Backprojected modified projections and sum

$$o(\xi, \eta) = \int_0^\pi Q_\varphi(\xi') d\varphi$$

$$Q_\varphi(\xi') = h(t) * P_\varphi(\xi') = \mathcal{F}^{-1} \{H(\omega)\} * P_\varphi(\xi')$$

$$H(\omega) = |\omega|$$

## Practical implementation of filtered backprojection

- ▶ **Problem:** Ideal filter  $H(\omega) = |\omega|$  amplifies noise
- ▶ **Solution 1:** Make  $\hat{P}_\varphi(\omega)$  frequency limited.  
Ramakrishnan-Lakshiminyanan  $\rightarrow$  Ram-Lak filter:

$$H(\omega) = \begin{cases} |\omega| & \text{if } |\omega| \leq \Omega \\ 0 & \text{otherwise} \end{cases}$$

## Practical implementation of filtered backprojection

- ▶ **Problem:** Ideal filter  $H(\omega) = |\omega|$  amplifies noise
- ▶ **Solution 1:** Make  $\hat{P}_\varphi(\omega)$  frequency limited.  
Ramakrishnan-Lakshiminyan → Ram-Lak filter:

$$H(\omega) = \begin{cases} |\omega| & \text{if } |\omega| \leq \Omega \\ 0 & \text{otherwise} \end{cases}$$

- ▶ Ram-Lak filter causes artefacts (Gibbs). Many solutions (Hamming filter, Shepp-Logan filter). Typically Hamming has better SNR but lower resolution.

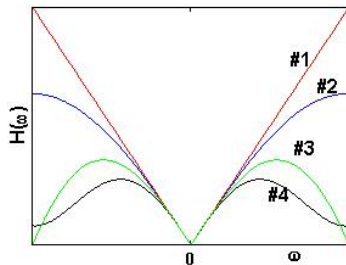

# Analytická rekonstrukce - filtrovaná ZP

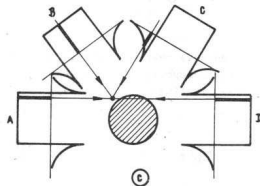
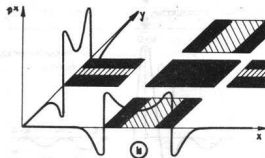
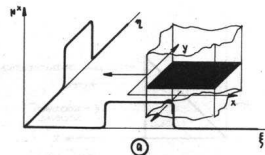
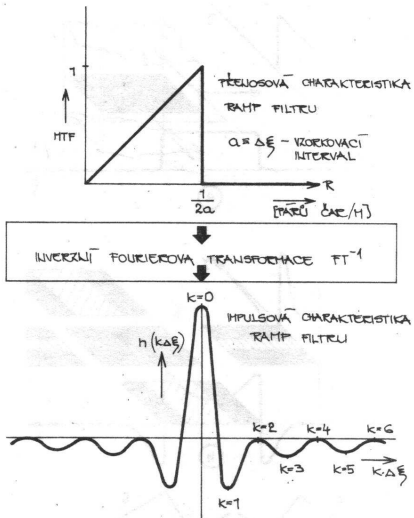

## Filtered backprojection

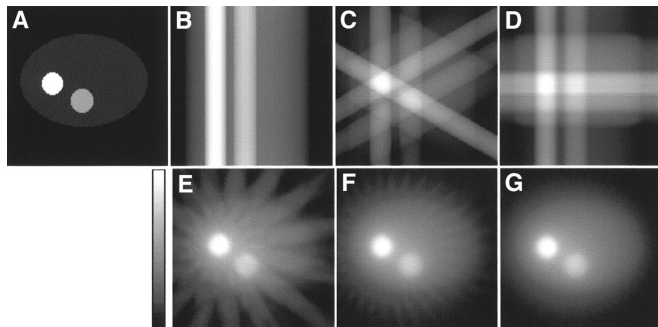

original image, 1,3, 4, 16, 32, a 64 projections

# Algebraic reconstruction

- ▶ setup equations, often linear

$$p_i = \sum_j w_{ij} f_j$$

where  $f_j$  are pixel values,  $p_i$  are projections

- ▶ We know  $p_i$  and  $w_{ij}$ , solve for  $f_j$
- ▶ Many unknowns, iterative method
  - ▶ Compare measured projections and simulations
  - ▶ Correct pixel values to decrease the difference
  - ▶ Iterate until convergence



## Algebraic reconstruction — advantages over FBP

- ▶ Better modeling of the physics — attenuation, resolution, noise
- ▶ Better handling of limited acquisition — restricted region, restricted angles
- ▶ Can use an image model
- ▶ Less apparent artifacts

# Iterativní rekonstrukce - ART

---

**ART – Algebraic Reconstruction Technique** je jedním z mnoha použitých algoritmů, které se používají do současnosti. Existují dva základní typy ART:

- aditivní

$$\hat{f}_{ij}^l = \hat{f}_{ij}^{l-1} + \frac{g_j - \sum_{i=1}^N \hat{f}_{ij}^{l-1}}{N}$$

- multiplikativní

$$\hat{f}_{ij}^l = \frac{g_j}{\sum_{i=1}^N \hat{f}_{ij}^{l-1}} \hat{f}_{ij}^{l-1}$$

# Iterativní rekonstrukce – ART pokračování

- kde:  $\hat{f}_{ij}^l$  - odhad hodnoty  $i$ -tého voxelu podél  $j$ -tého paprsku během  $l$ -té iterace,
- $g_j$  - skutečný paprskový součet (data) podél  $j$ -tého paprsku,
- $N$  - počet objemových elementů (voxelů) podél  $j$ -tého paprsku,

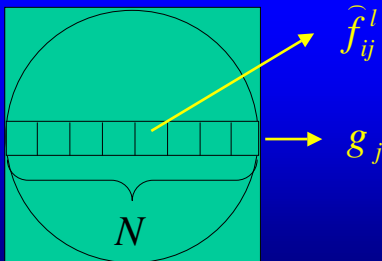

# Iterativní rekonstrukce – ART aditivní - příklad

- skutečná naměřená data (projekce a paprskové součty)

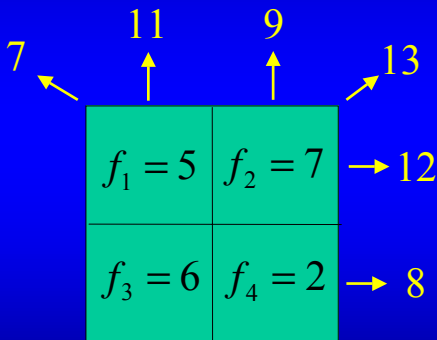

# Iterativní rekonstrukce – ART př. – pokrač.

1/3  
vertikální paprsky

	0		0
	↑		↑
0		0	
0		0	

	11	9	
7	↑	↑	13
	$f_1 = ?$	$f_2 = ?$	→ 12
	$f_3 = ?$	$f_4 = ?$	→ 8

$$\widehat{f}_1^{1/3} = \widehat{f}_3^{1/3} = 0 + \frac{11 - 0}{2} = 5,5$$

$$\widehat{f}_2^{1/3} = \widehat{f}_4^{1/3} = 0 + \frac{9 - 0}{2} = 4,5$$

# Iterativní rekonstrukce – ART př. – pokrač.

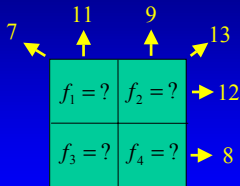

**2/3**

**horizontální paprsky**

5,5	4,5	→ 10
5,5	4,5	→ 10

$$\widehat{f}_1^{2/3} = 5,5 + \frac{12-10}{2} = 6,5$$

$$\widehat{f}_2^{2/3} = 4,5 + \frac{12-10}{2} = 5,5$$

$$\widehat{f}_3^{2/3} = 5,5 + \frac{8-10}{2} = 4,5$$

$$\widehat{f}_4^{2/3} = 4,5 + \frac{8-10}{2} = 3,5$$

# Iterativní rekonstrukce – ART př. – pokrač.

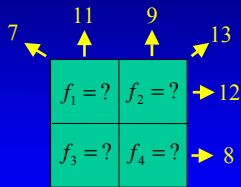

$3/3=1$

diagonální paprsky



6,5	5,5
4,5	3,5

$$\hat{f}_1^1 = 6,5 + \frac{7-10}{2} = 5$$

$$\hat{f}_2^1 = 5,5 + \frac{13-10}{2} = 7$$

$$\hat{f}_3^1 = 4,5 + \frac{13-10}{2} = 6$$

$$\hat{f}_4^1 = 3,5 + \frac{7-10}{2} = 2$$

viz  
orig.  
data

Konvergence

## Electric processing — corrections

- ▶ Offset correction (zero signal at rest)
- ▶ Normalization correction (x-ray source intensity fluctuation)
- ▶ Sensitivity correction (inhomogeneous detectors and amplifiers)
- ▶ Geometric correction
- ▶ Beam hardening correction
- ▶ Cosine correction



# CT systémy 3. generace

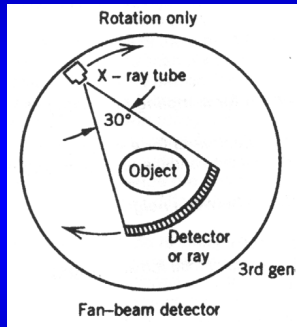
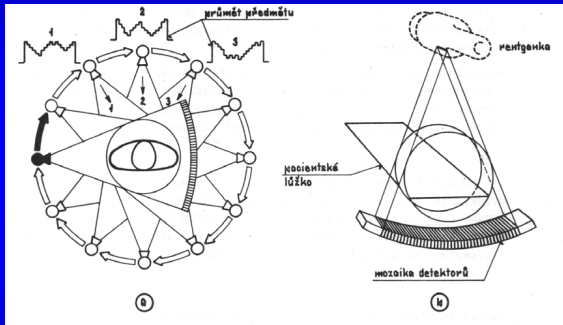

asi nejčastěji používané

# Fan-beam reconstruction

- ▶ Rays not parallel, not a Radon transform.
- ▶ Rebinning

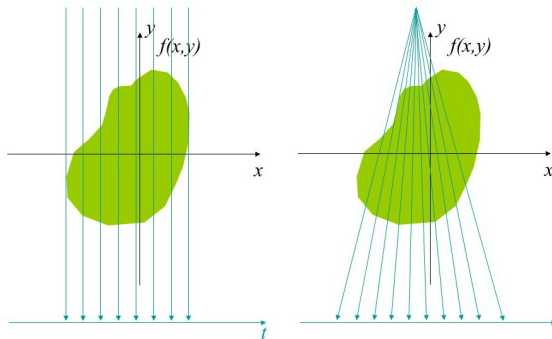

image courtesy of Gillian Henderson

# Fan-beam reconstruction

- ▶ Rays not parallel, not a Radon transform.
- ▶ Rebinning

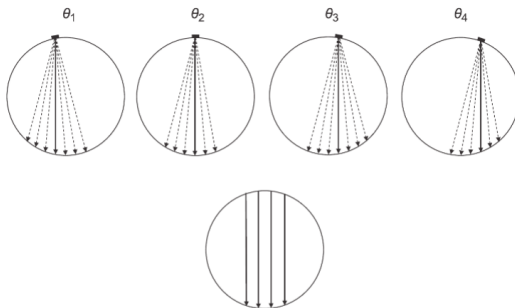

image courtesy of Jonathan Mamou and Yao Wang

## Fan-beam reconstruction (2)

- ▶ Rays not parallel, not a Radon transform.
- ▶ Rebinning
- ▶ Modified filtered backprojection (quadratic cosine correction,  $\cos \theta$ ).

## Fan-beam reconstruction (2)

- ▶ Rays not parallel, not a Radon transform.
- ▶ Rebinning
- ▶ Modified filtered backprojection (quadratic cosine correction,  $\cos \theta$ ).
- ▶ Algebraic reconstruction. Best quality but slow.

## 3D computed tomography

- ▶ Technical challenges: power, cooling
- ▶ Rotation method (slice by slice)
- ▶ Spiral/helix method

# Spiral method

- ▶ Acceleration: 10 min → 1 min

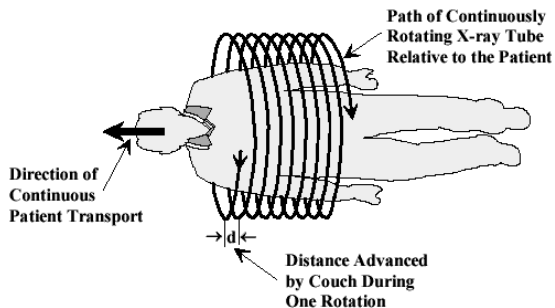

## Spiral method

- ▶ Acceleration: 10 min  $\rightarrow$  1 min
- ▶ *Pitch*:

$$P = \Delta l / d$$

$\Delta l$  bed shift per rotation,  $d$  slice thickness.

Normally  $0 < P < 2$ . Overlap for  $P < 1$ . Typically  $P = 1.5$ .

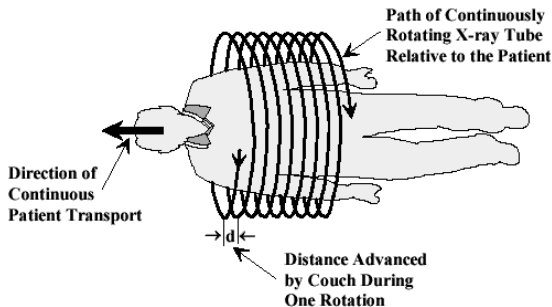



## Spiral method (2)

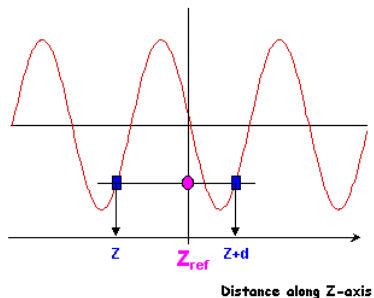

- ▶ Interpolation in  $z$  axis
- ▶ Interpolation *wide* — 1 turn. Less noise, larger effective slice thickness.
- ▶ Interpolation *Slim* — 1/2 turn, symmetry. More noise, smaller effective slice thickness.
- ▶ Multislice acquisition — acceleration.

## Radiation dose

- ▶ Absorbed dose  $D$ . 1 Gy (gray) = 1 J/kg Before 1 Gy = 100 rad
- ▶ Effective dose equivalent (dávkový ekvivalent)  
 $H_E$  [Sv] (sievert)

$$H_E = \sum_i w_i H_i$$

$H = cD$ . Quality factor  $c$  is 1 for X-rays and  $\gamma$  rays, 10 for neutrons, 20 for  $\alpha$  particles.

Coefficient  $w$  is organ dependent: male/female glands 0.2, lungs 0.12, breast 0.1, stomach 0.12, thyroid gland 0.05, skin 0.01.

Before 1 Sv = 100 rem

## Radiation dose

- ▶ Absorbed dose  $D$ . 1 Gy (gray) = 1 J/kg Before 1 Gy = 100 rad
- ▶ Effective dose equivalent (dávkový ekvivalent)  
 $H_E$  [Sv] (sievert)

$$H_E = \sum_i w_i H_i$$

$H = cD$ . Quality factor  $c$  is 1 for X-rays and  $\gamma$  rays, 10 for neutrons, 20 for  $\alpha$  particles.

Coefficient  $w$  is organ dependent: male/female glands 0.2, lungs 0.12, breast 0.1, stomach 0.12, thyroid gland 0.05, skin 0.01.

Before 1 Sv = 100 rem

- ▶ Sum the doses

## Radiation dose

- ▶ Medical limit (USA) is 50 mSv/year (=limit for a person working with radiation in CR), corresponding to 1000 chest X-rays, or 15 head CTs, or 5 whole body CTs (1 CT  $\approx$  10 mSv).
- ▶ low-dose CT  $\approx$  2 ~ 5 mSv, PET  $\approx$  25 mSv
- ▶ In CR radioactive background about 3 mSv/year (mainly radon), similar to USA. In Colorado (altitude 1500 ~ 4000 m) about 4.5 mSv/year. Mean dose from medical imaging 0.3 mSv/year, about 3 long flights.

## Radiation dose

- ▶ Medical limit (USA) is 50 mSv/year (=limit for a person working with radiation in CR), corresponding to 1000 chest X-rays, or 15 head CTs, or 5 whole body CTs (1 CT  $\approx$  10 mSv).
- ▶ low-dose CT  $\approx$  2  $\sim$  5 mSv, PET  $\approx$  25 mSv
- ▶ In CR radioactive background about 3 mSv/year (mainly radon), similar to USA. In Colorado (altitude 1500  $\sim$  4000 m) about 4.5 mSv/year. Mean dose from medical imaging 0.3 mSv/year, about 3 long flights.
- ▶ cancer related death 20%. 1 CT=10 mSv — relative increase by  $10^{-3} \sim 10^{-4}$

# CT image quality

- ▶ Parameters:
  - ▶ Resolution (0.5 mm)
  - ▶ Contrast ( $\delta H$ , about 5 – 10 H.j.)
  - ▶ Detection threshold (about 1 mm at  $\Delta H = 200$ , 5 mm at  $\Delta H = 5$ ).
  - ▶ Noise (SNR)
- ▶ Artifacts
  - ▶ Scanner defects, malfunctions, operator error
  - ▶ Metal parts (shadows)
  - ▶ Motion artifacts
  - ▶ Partial volume

## Artifact examples

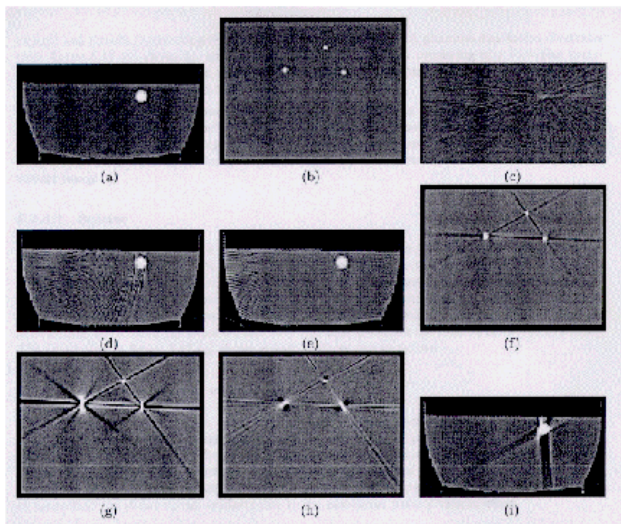

Figure 2.19 Example of image artifacts: (a) test phantom, (b) second phantom, (c) noise, (d) detector under-sampling, (e) view under-sampling, (f) beam hardening, (g) scatter, (h) nonlinear partial volume effect, and (i) object motion. (unpublished results)

## Clinical applications

### ▶ Lungs





## Clinical applications

▶ Lungs

▶ Head

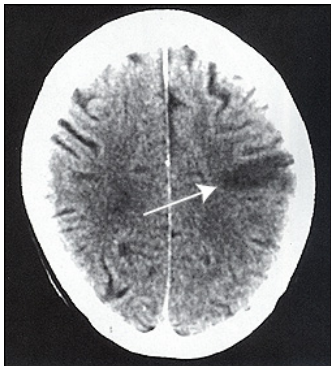

# Clinical applications

- ▶ Lungs
- ▶ Head
- ▶ Abdomen

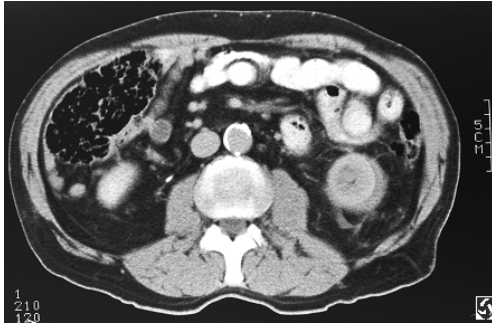

## Computed tomography, conclusions

- ▶ Excellent spatial resolution
- ▶ 3D image
- ▶ Fast acquisition
- ▶ Weak soft tissue contrast
- ▶ Reconstruction algorithm
- ▶ Radiation dose