



**OPPA European Social Fund
Prague & EU: We invest in your future.**



DCGI

DEPARTMENT OF COMPUTER GRAPHICS AND INTERACTION

INTERSECTIONS OF LINE SEGMENTS AND POLYGONS

PETR FELKEL

FEL CTU PRAGUE

felkel@fel.cvut.cz

<https://cw.felk.cvut.cz/doku.php/courses/a4m39vg/start>

Based on [Berg], [Mount], [Kukral], and [Drtina]

Version from 21.11.2012

Talk overview

- Intersections of line segments (Bentley-Ottmann)
 - Motivation
 - Sweep line algorithm recapitulation
 - Sweep line intersections of line segments
- Intersection of polygons or planar subdivisions
 - See assignment [21] or [Berg, Section 2.3]
- Intersection of axis parallel rectangles
 - See assignment [26]



Geometric intersections – what are they for?

One of the most basic problems in computational geometry

- Solid modeling
 - Intersection of object boundaries in CSG
- Overlay of subdivisions, e.g. layers in GIS
 - Bridges on intersections of roads and rivers
 - Maintenance responsibilities (road network X county boundaries)
- Robotics
 - Collision detection and collision avoidance
- Computer graphics
 - Rendering via ray shooting (intersection of the ray with objects)
- ...



Line segment intersection

- Intersection of complex shapes is often reduced to simpler and simpler intersection problems
- **Line segment intersection** is the most basic intersection algorithm
- **Problem statement:**
Given n line segments in the plane, report all points where a pair of line segments intersect.
- **Problem complexity**
 - Worst case – $I = O(n^2)$ intersections
 - Practical case – only some intersections
 - Use an **output sensitive algorithm**
 - $O(n \log n + I)$ optimal randomized algorithm
 - $O(n \log n + I \log n)$ **sweep line algorithm** - %

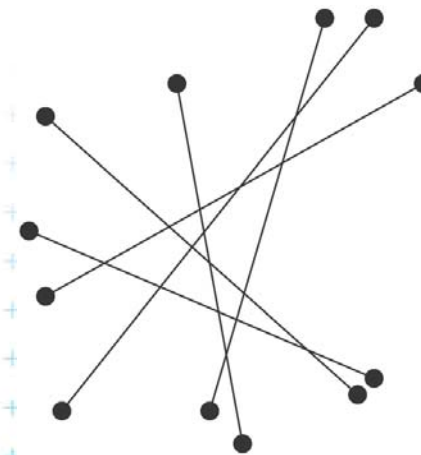

[Berg]



Plane sweep line algorithm recapitulation

- Horizontal line (**sweep line**, *scan line*) ℓ moves top-down (or vertical line: left to right) over the set of objects
- The move is not continuous, but ℓ **jumps from one event point to another**
 - Event points are in **priority queue** or sorted list
 - The left-most event point is removed first
 - **New event points** may be created (usually as interaction of **neighbors** on the sweep line) and **inserted in the queue**
- **Scan-line status**
 - Stores information about the objects intersected by SL
 - It is updated while stopping on event point



Line segment intersection - Sweep line alg.

- Avoid testing of pairs of segments far apart
- Compute **intersections of neighbors** on the sweep line only
- $O(n \log n + I \log n)$ time in $O(n)$ memory
 $2n$ steps for end points, I steps for intersections, $\log n$ search the tree
- Ignore “nasty cases” (most of them will be solved later on)
 - No segment is parallel to a sweep line
 - Segments intersect in one point and do not overlap
 - No three segments meet in a common point

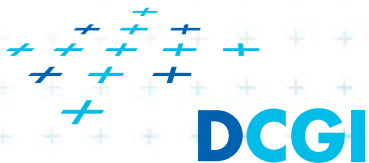

Line segment intersections

- *Status* = ordered sequence of segments intersecting the sweep line ℓ
- *Events* (waiting in the priority queue)
 - = points, where the algorithm actually does something
 - Segment *end-points*
 - known at algorithm start
 - Segment *intersections* between neighboring segments along SL
 - Discovered as the sweep executes



Detecting intersections

- Intersection events must be **detected** and inserted to the event queue **before they occur**
- Given two segments a, b intersecting in a point p , there must be a placement of sweep line ℓ prior to p , such that segments a, b are **adjacent along ℓ** (only adjacent will be tested for intersection)
 - segments a, b are not adjacent when the alg. starts
 - segments a, b are adjacent just before p

=> there must be an event point when a, b become adjacent and therefore are tested for intersection

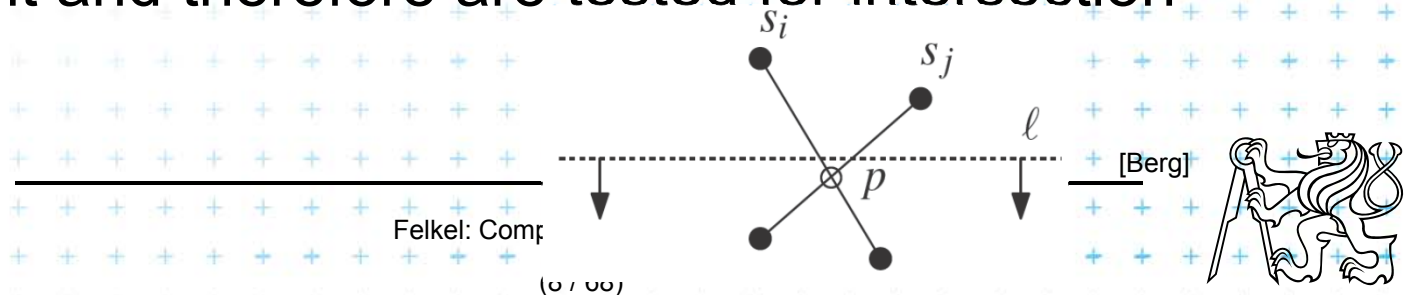

Data structures

Sweep line ℓ **status** = order of segments along ℓ

- Balanced binary search tree of segments
- Coords of intersections with ℓ vary as ℓ moves
=> store pointers to line segments in tree nodes
 - Position of ℓ is plugged in the $y=mx+b$ to get the key

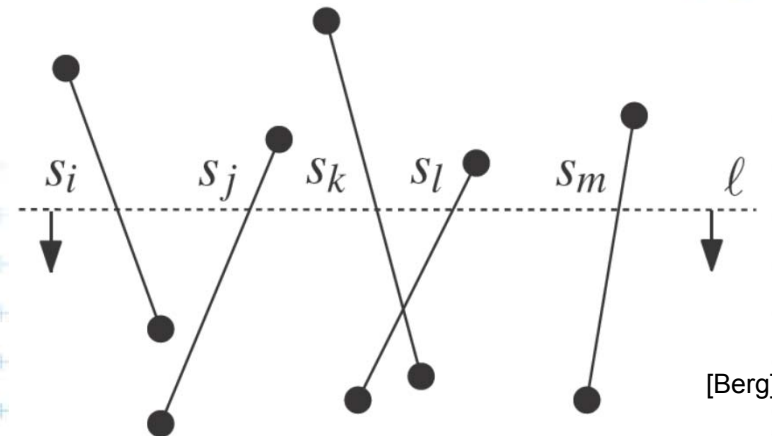
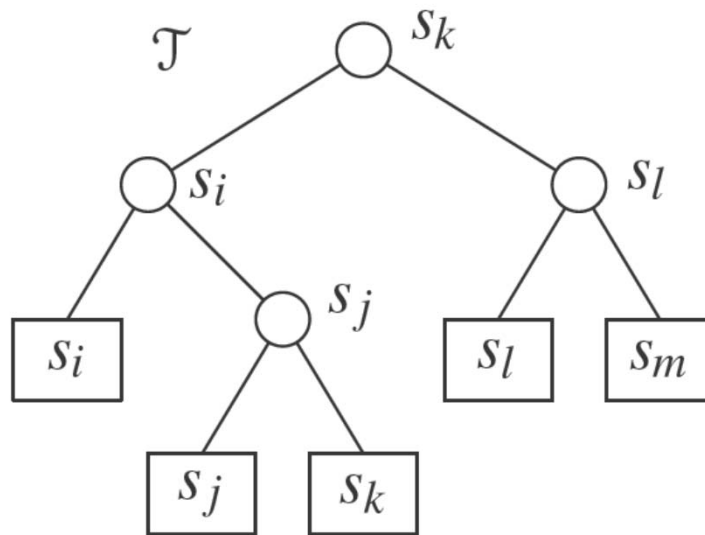

[Berg]



Data structures

Event queue (postupový plán, časový plán)

- Define: **Order** $<$ (top-down, lexicographic)

$p < q$ **iff** $p_y > q_y$ **or** $p_y = q_y$ and $p_x < q_x$

top-down, left-right approach

(points on ℓ treated left to right)

- Operations

- **Insertion** of computed intersection points
- Fetching the **next event** (highest y below ℓ)
- **Test**, if the segment is already **present in the queue**
- (**Delete** intersection event in the queue)

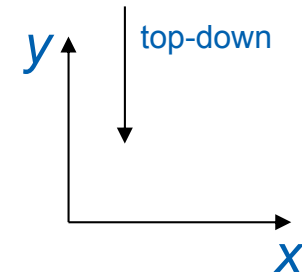

Problem with duplicities of intersections

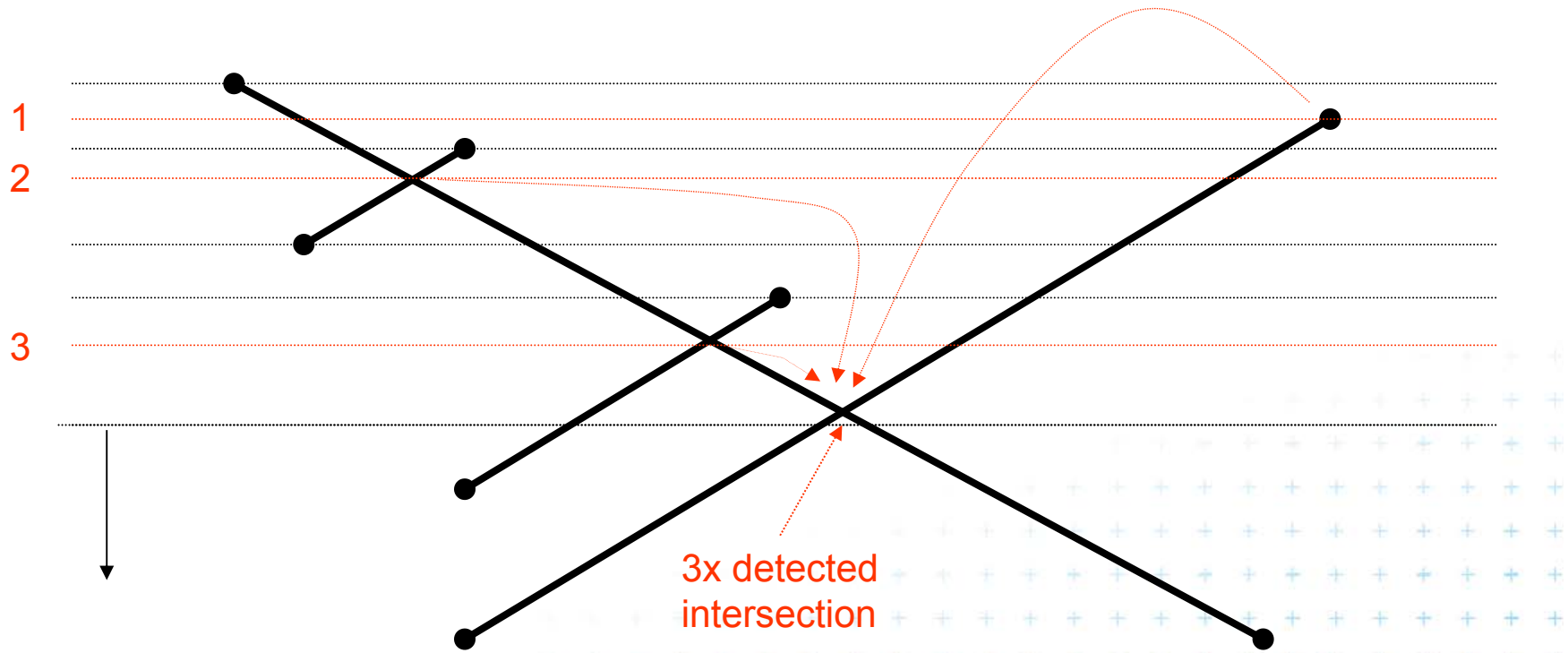

Data structures

Event queue data structure

■ Heap

- Problem: can not check **duplicated intersection events** (reinvented more than once)
- Intersections processed twice or even more
- Memory complexity up to $O(n^2)$

■ Ordered dictionary (balanced binary tree)

- Can check duplicated events (adds just constant factor)
- Nothing inserted twice
- If non-neighbor intersections are deleted i.e., only intersection of neighbors is stored then memory complexity just $O(n)$

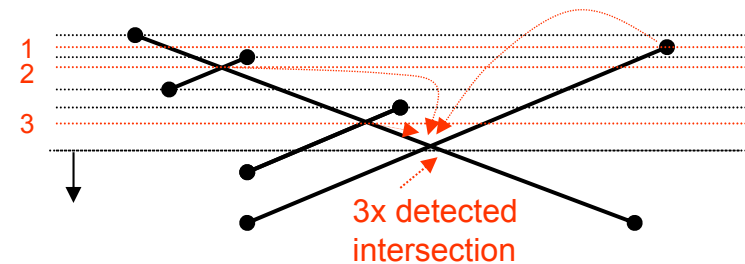

Line segment intersection algorithm

FindIntersections(S)

Input: A set S of line segments in the plane

Output: The set of intersection points + pointers to segments in each

1. init an empty event queue Q and insert the segment endpoints
2. init an empty status structure T
3. **while** Q in not empty
4. remove next event p from Q
5. handleEventPoint(p)

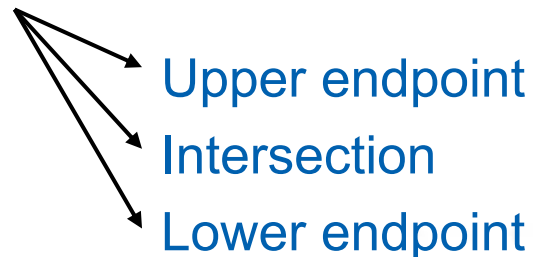

Note: Upper-end-point events store info about the segment



handleEventPoint principle

- Upper endpoint $U(p)$
 - insert p (on s_j) to status T
 - add intersections with left and right neighbors to Q
- Intersection $C(p)$
 - switch order of segments in T
 - add intersections of left and right neighbors to Q
- Lower endpoint $L(p)$
 - remove p (on s_l) from T
 - add intersections of left and right neighbors to Q

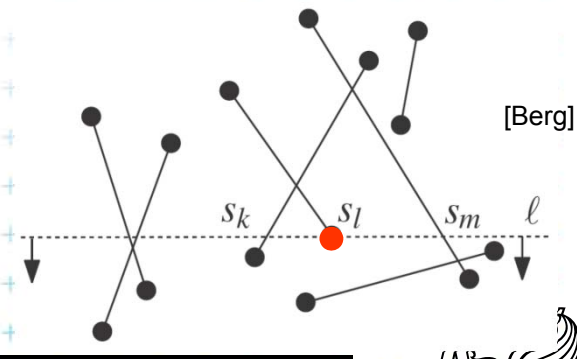
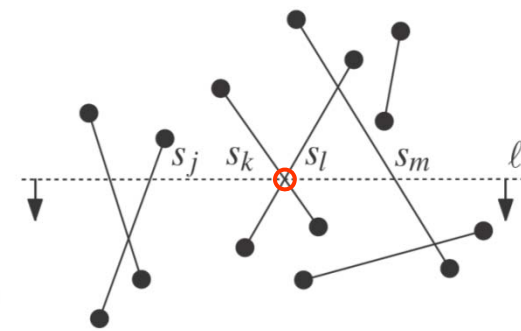
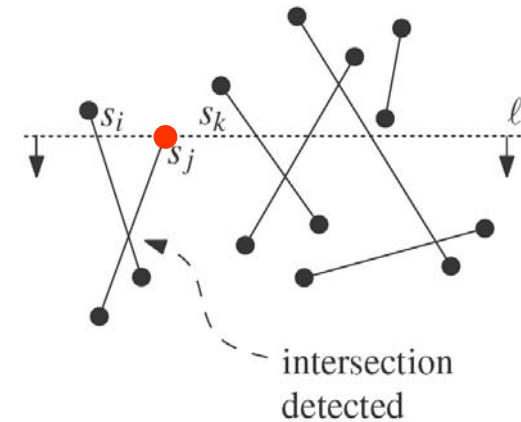

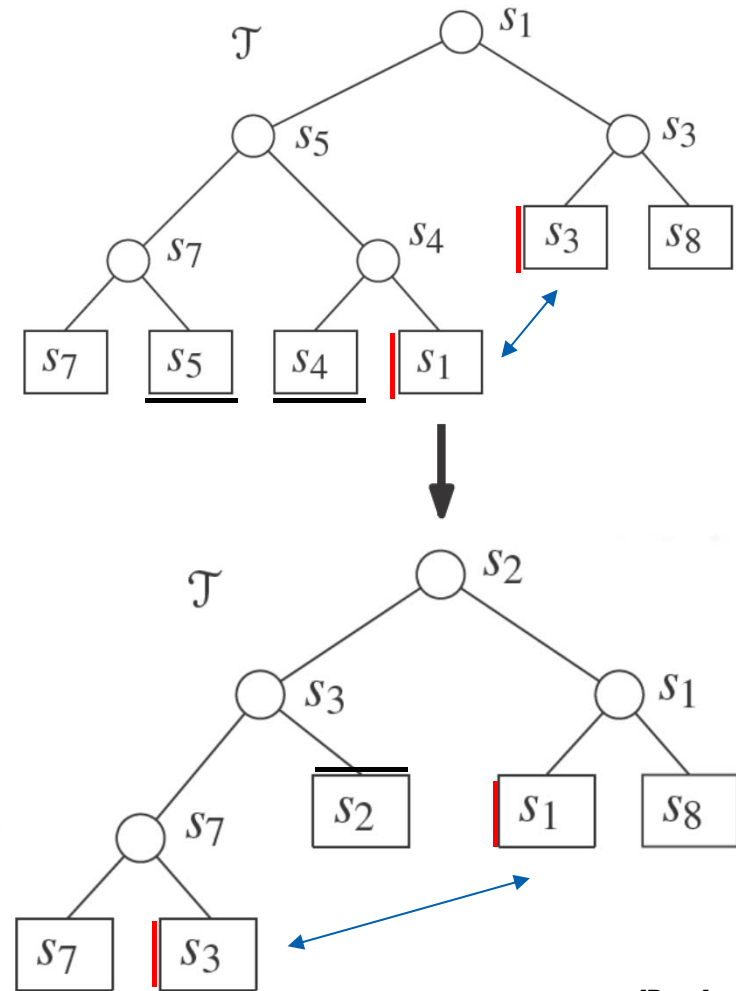
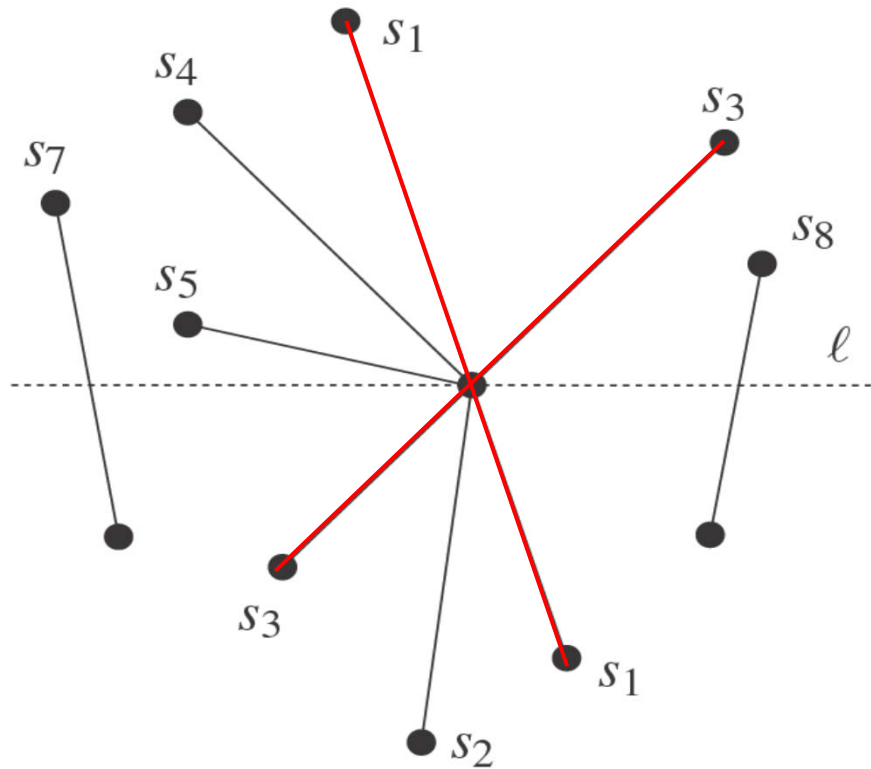

More than two segments incident



$$U(p) = \{s_2\}$$

$$C(p) = \{s_1, s_3\}$$

$$L(p) = \{s_4, s_5\}$$

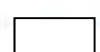
-  start here
-  cross on l
-  end here



Handle Events [Berg, page 25]

handleEventPoint(p)

1. Let $U(p)$ = set of segments whose upper point is p .
These segments are stored with the event point p (will be added to T)
2. Search T for all segments $S(p)$ that contain p (are adjacent in T):
Let $L(p) \subset S(p)$ = segments whose lower endpoint is p
Let $C(p) \subset S(p)$ = segments that contains p in interior
3. if($L(p) \cup U(p) \cup C(p)$ contains more than one segment)
4. report p as intersection together with $L(p), U(p), C(p)$
5. Delete the segments in $L(p) \cup C(p)$ from T
6. Insert the segments in $U(p) \cup C(p)$ into T } Reverse order of $C(p)$ in T
(order as below ℓ , horizontal segment as the last)
7. if($U(p) \cup C(p) = \emptyset$) then findNewEvent(s_l, s_r, p) // left & right neighbors
8. else s' = leftmost segment of $U(p) \cup C(p)$; findNewEvent(s_l, s', p)
 s'' = rightmost segment of $U(p) \cup C(p)$; findNewEvent(s'', s_r, p)

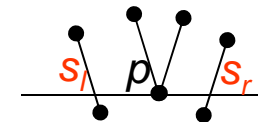
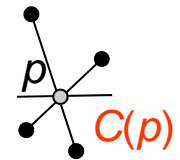
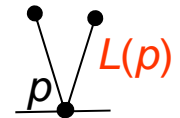
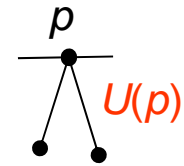

Detection of new intersections

findNewEvent(s_l, s_r, p) // with handling of horizontal segments

Input: two segments (left & right from p in T) and a current event point p

Output: updated event queue Q with new intersection

1. if [(s_l and s_r intersect below the sweep line ℓ) or
 (intersect on ℓ and to the right of p)] and // horizontal segments
 (the intersection is not present in Q)
2. then
 insert p as an event into Q

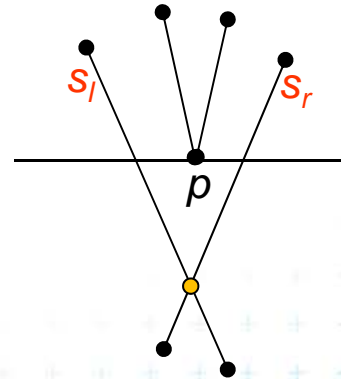

s_l and s_r intersect below

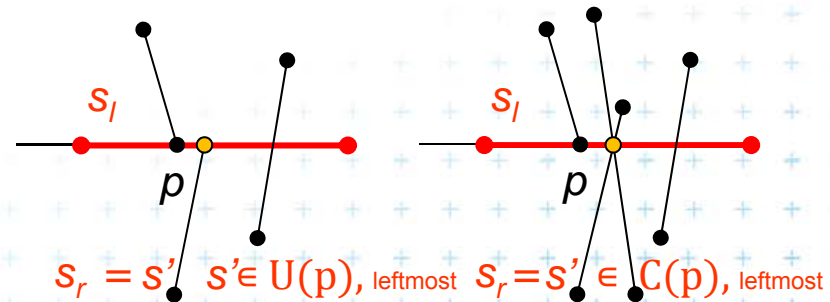

s_l and $s_r = s'$ intersect on ℓ

and to the right of p

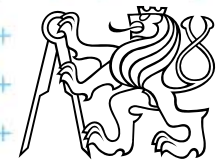

Line segment intersections

- Memory $O(I) = O(n^2)$ with duplicities in Q
or $O(n)$ with duplicities in Q deleted
- Operational complexity
 - $n + I$ stops
 - $\log n$ each
 - $\Rightarrow O(I + n) \log n$ total
- The algorithm is by Bentley-Ottmann

Bentley, J. L.; Ottmann, T. A. (1979), "Algorithms for reporting and counting geometric intersections", *IEEE Transactions on Computers* **C-28** (9): 643-647, doi:10.1109/TC.1979.1675432 .

See also http://wapedia.mobi/en/Bentley%E2%80%93Ottmann_algorithm



Intersection of axis parallel rectangles

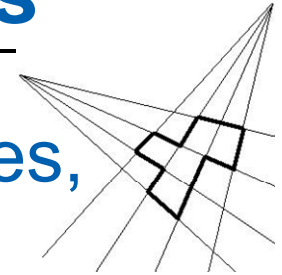

- Given the collection of n *isothetic* rectangles, report all intersecting parts

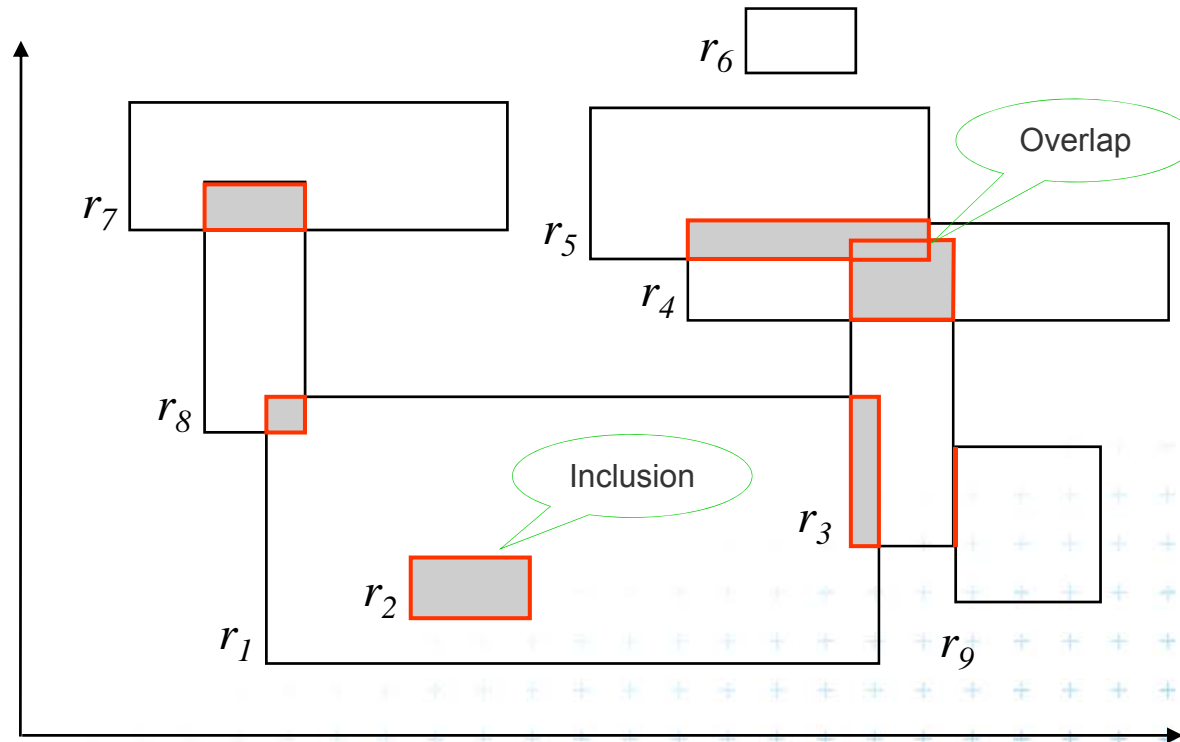

Answer: $(r_1, r_2) (r_1, r_3) (r_1, r_8) (r_3, r_4) (r_3, r_5) (r_4, r_5) (r_7, r_8) (r_3, r_9)$

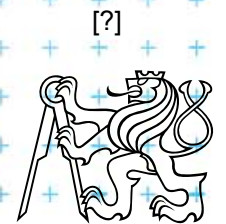

Brute force intersection

Brute force algorithm

Input: set S of axis parallel rectangles

Output: pairs of intersected rectangles

1. For every pair (r_i, r_j) of rectangles $\in S, i \neq j$
2. if $(r_i \cap r_j \neq \emptyset)$ then
3. report (r_i, r_j)

Analysis

Preprocessing: None.

Query: $O(N^2)$; $\binom{N}{2} = (N(N-1))/2 \in O(N^2)$.

Storage: $O(N)$.

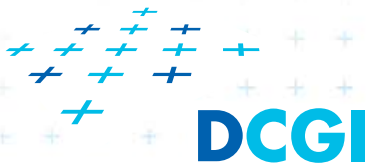

Plane sweep intersection algorithm

- Vertical sweep line moves from left to right
- Stops at every x-coordinate of a rectangle (either its left side or its right side).
- **active rectangles** – a set
 - = rectangles currently intersecting the sweep line
 - **left side** event of a rectangle
 - => the rectangle is **added** to the active set.
 - **right side**
 - => the rectangle is **deleted** from the active set.
- The active set used to detect rectangle intersection



Example rectangles and sweep line

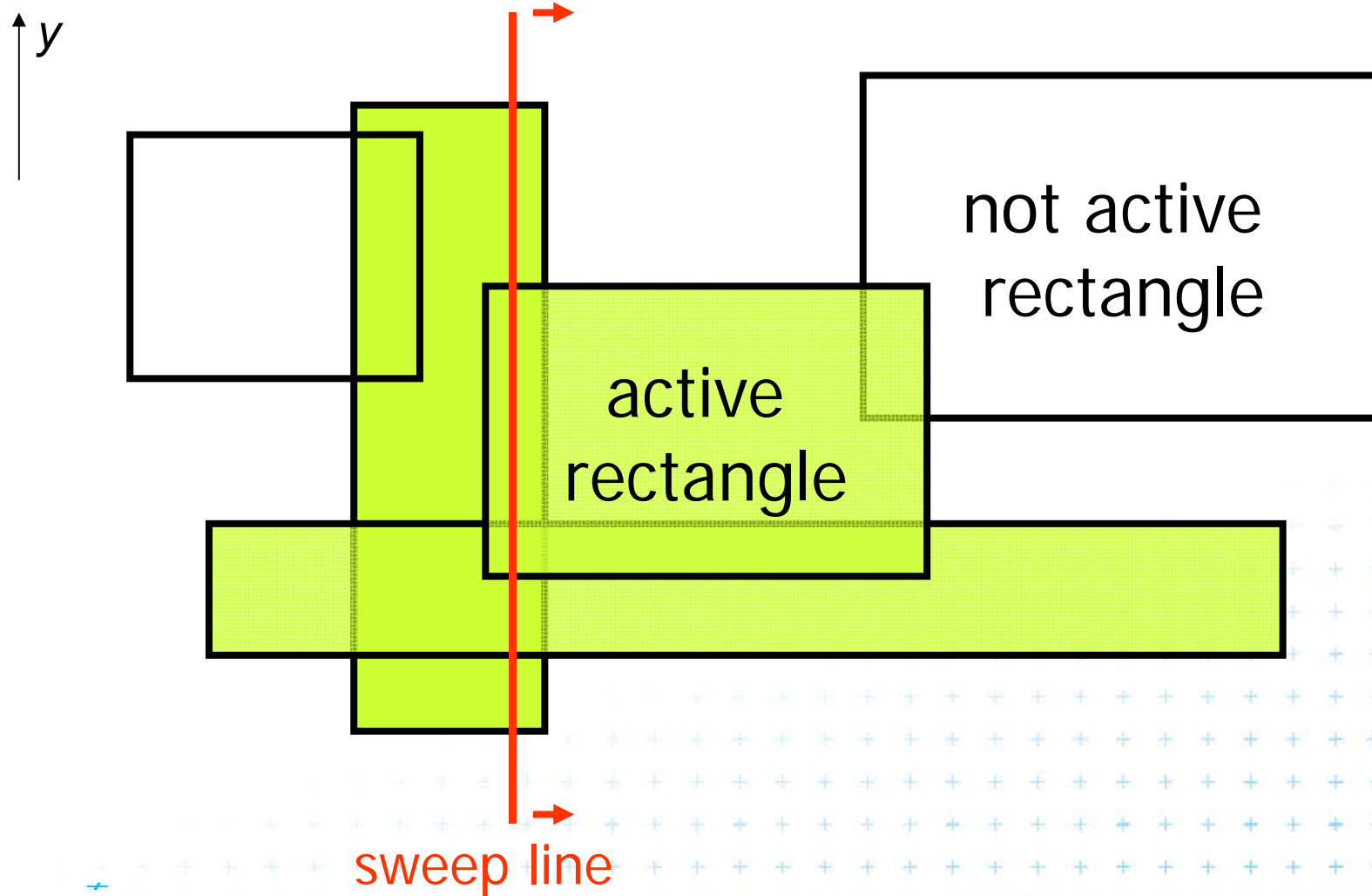

Interval tree as sweep line status structure

- Vertical sweep-line => Only y -coordinates along it
- Turn our view in slides 90° right
- Sweep line (y -axis) will be drawn as horizontal

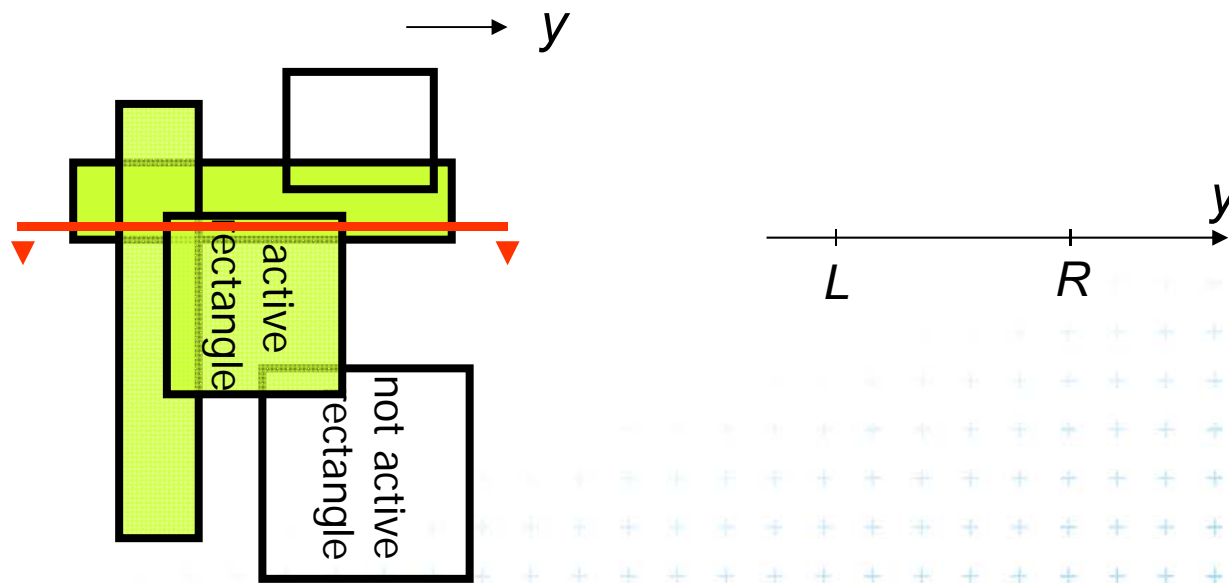

sweep line [Drtina]



Intersection test – between pair of intervals

- Given two intervals $R = [y_1, y_2]$ and $R' = [y'_1, y'_2]$ the condition $R \cap R'$ is equivalent to one of these mutually exclusive conditions:

a) $y_1 \leq y'_1 \leq y_2$

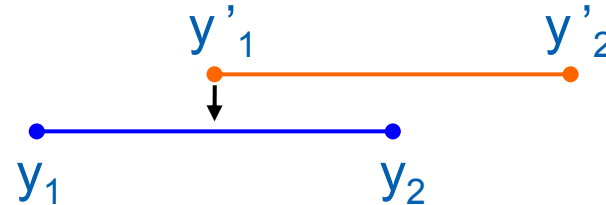

b) $y'_1 \leq y_1 \leq y'_2$

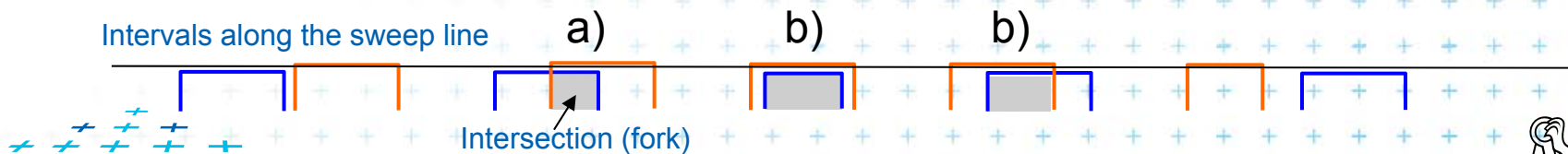
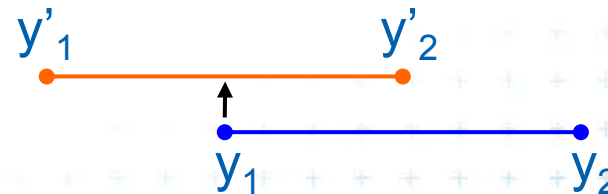

Static interval tree – stores all end points

- Let $v = y_{med}$ be the **median of end-points** of segments
- S_l : segments of S that are completely to the left of y_{med}
- S_{med} : segments of S that contain y_{med}
- S_r : segments of S that are completely to the right of y_{med}

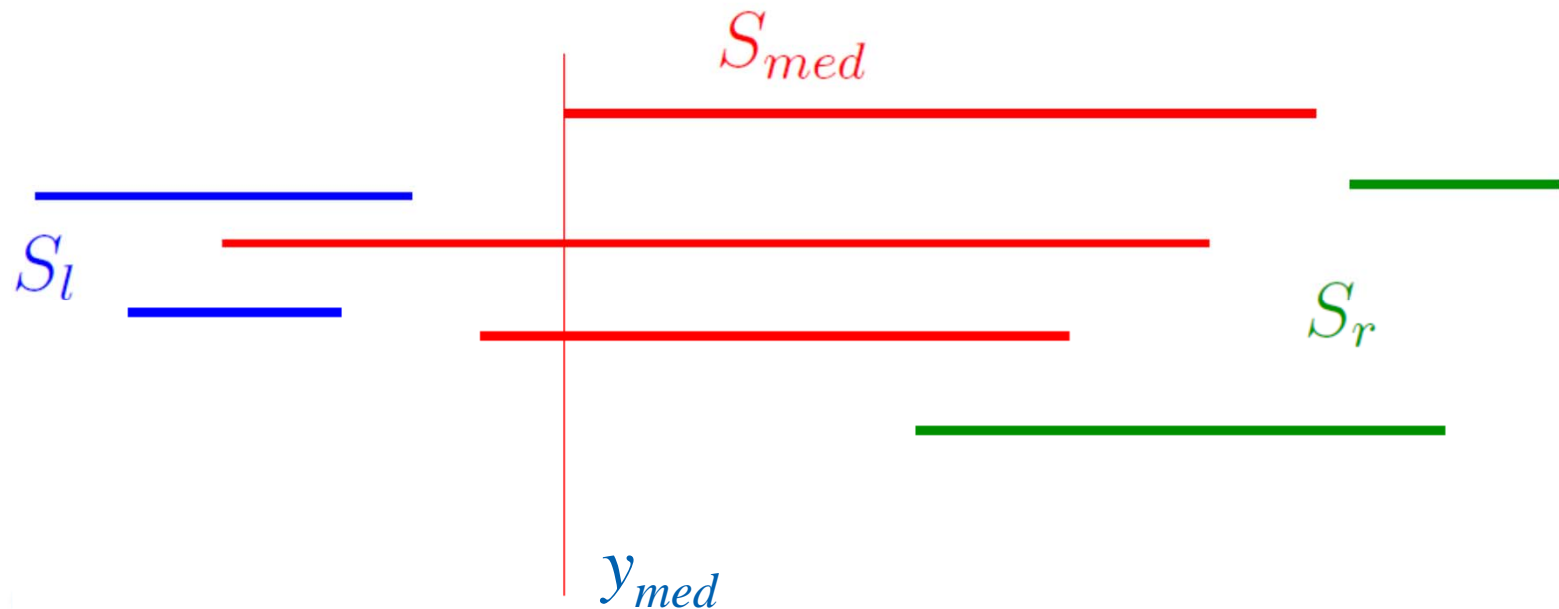

Static interval tree – Example

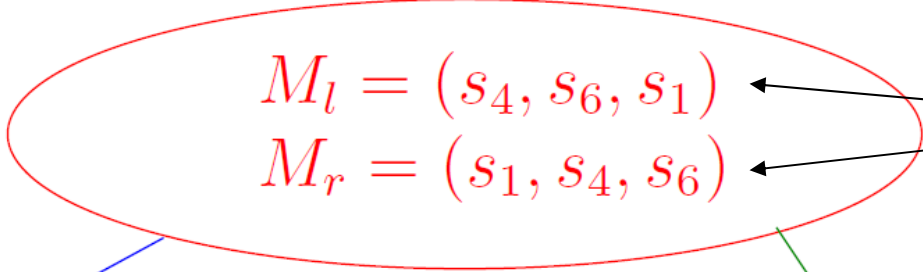

Left ends – ascending →
 Right ends – descending ←

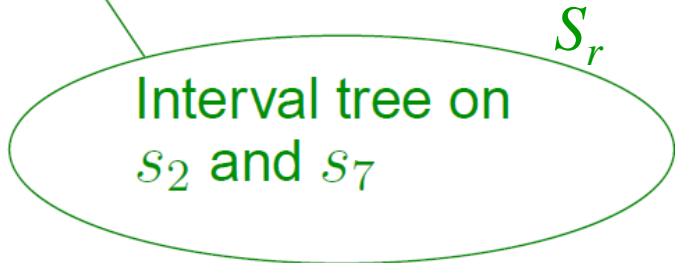
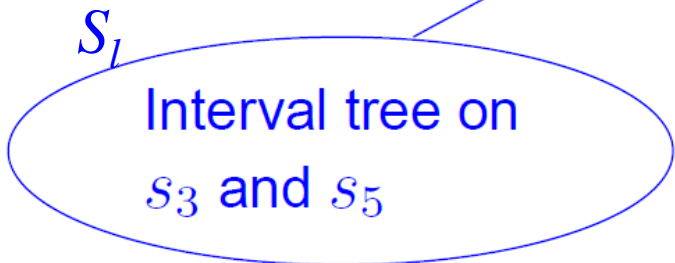

Static interval tree [Edelsbrunner80]

- Stores intervals along y sweep line
- 3 kinds of information
 - end points
 - incident intervals
 - active nodes

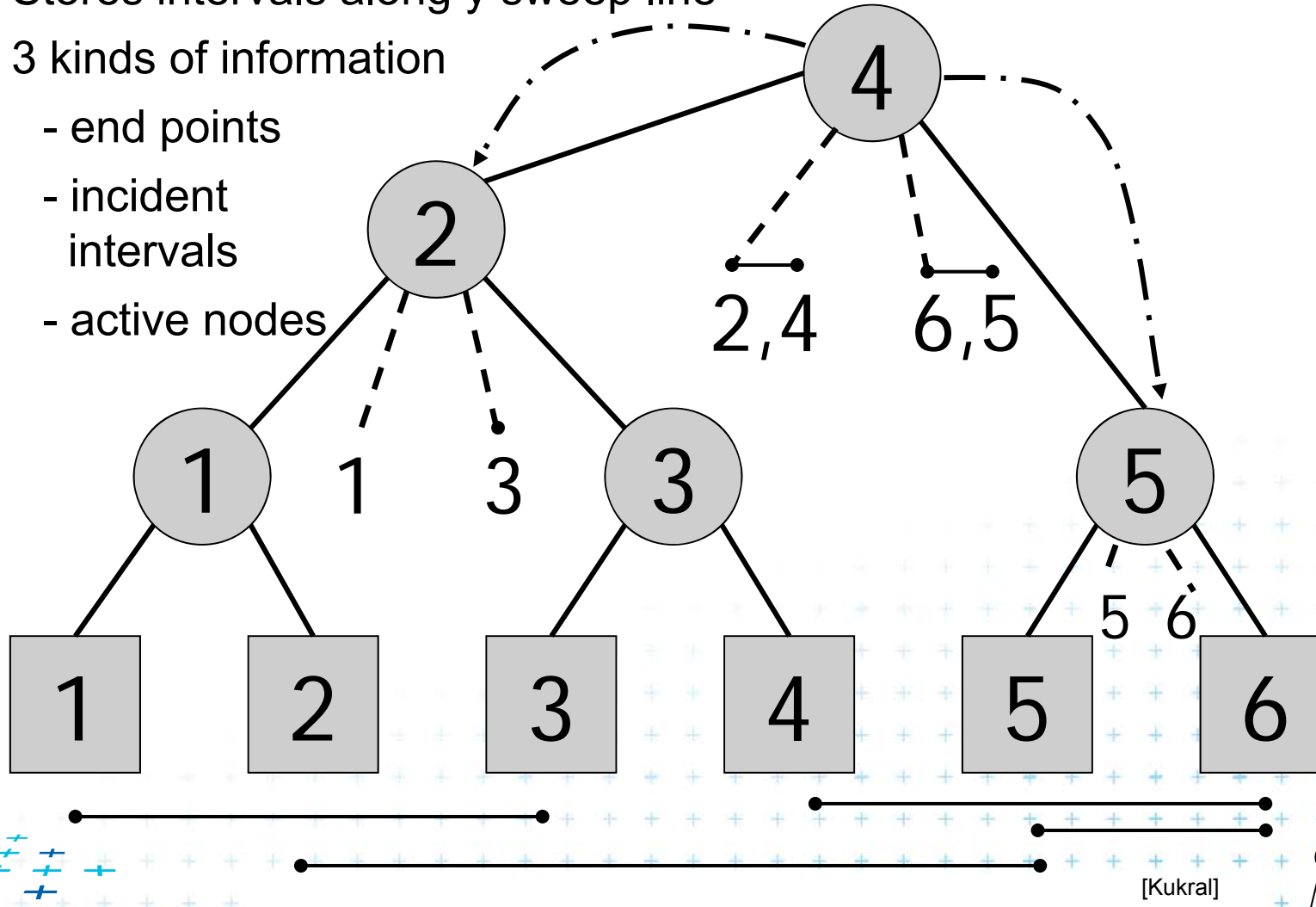

Primary structure – static tree for endpoints

v = midpoint of all
segment endpoints

$H(v)$ = value (y-coord) of v

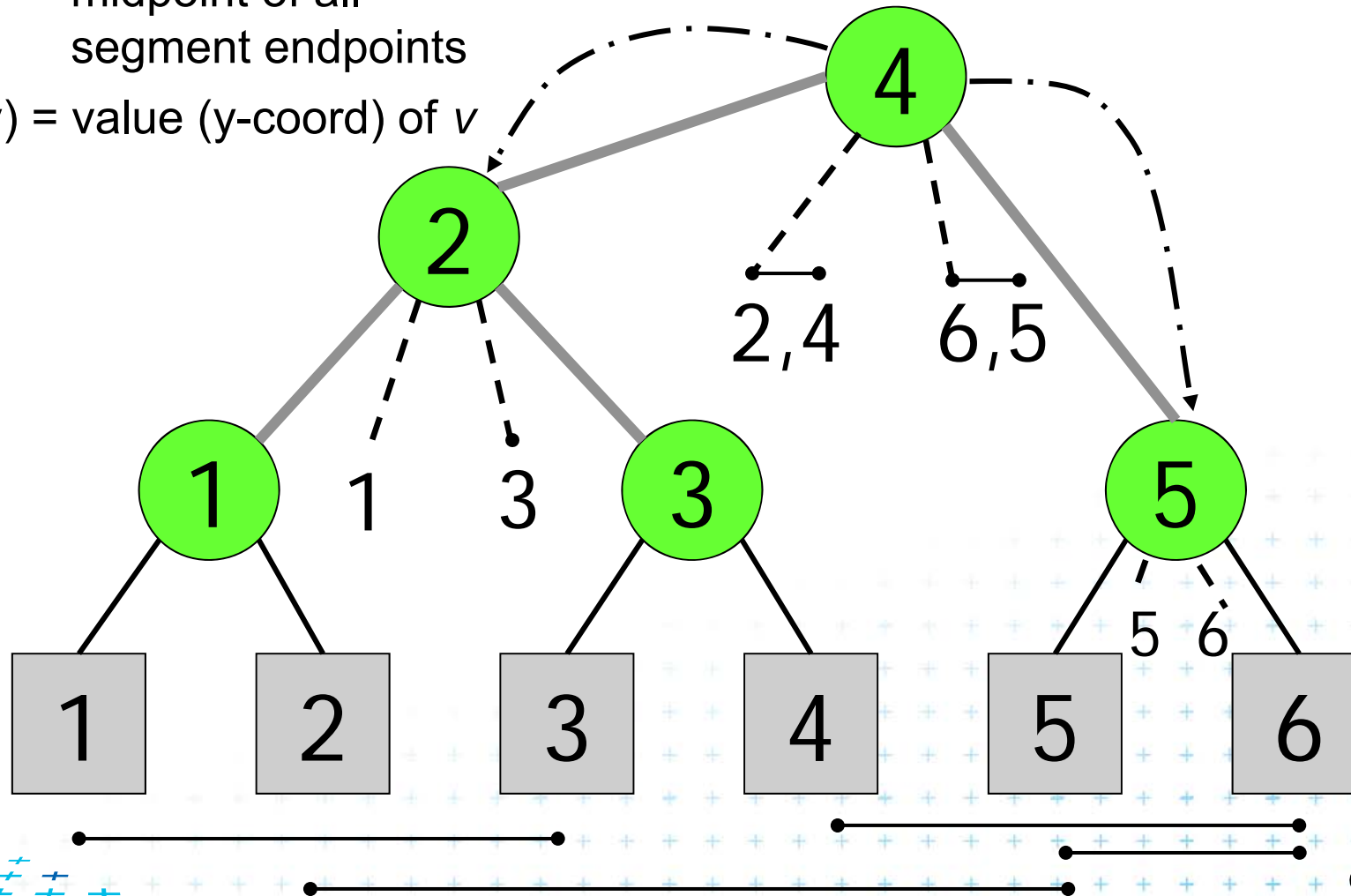

Secondary lists of incident interval end-pts.

ML(v) – left endpoints of interval containing v
(sorted ascending)

MR(v) – right endpoints
(descending)

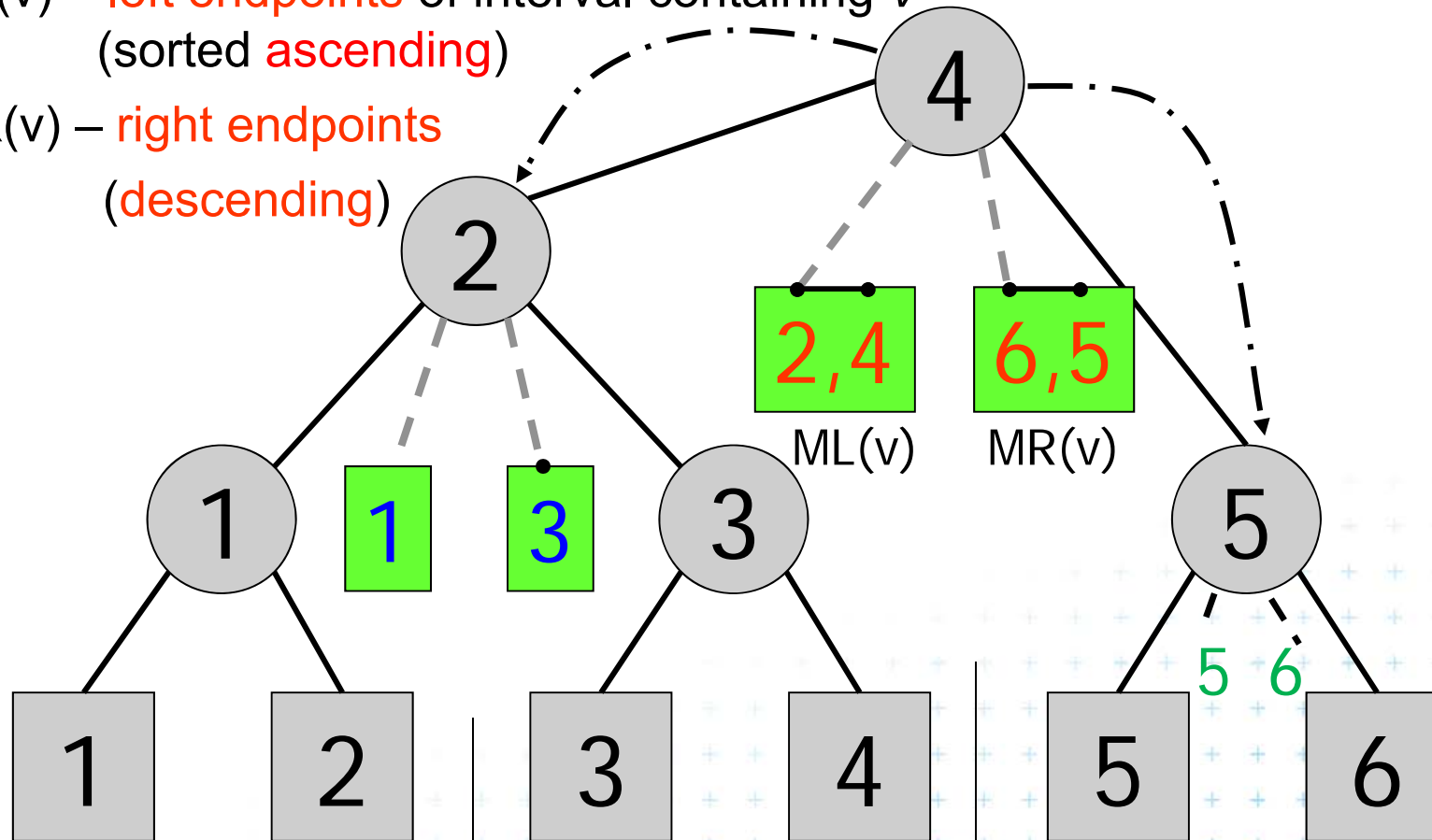

Active nodes – intersected by the sweep line

Subset of all nodes at present intersected by sweep line (nodes with intervals)

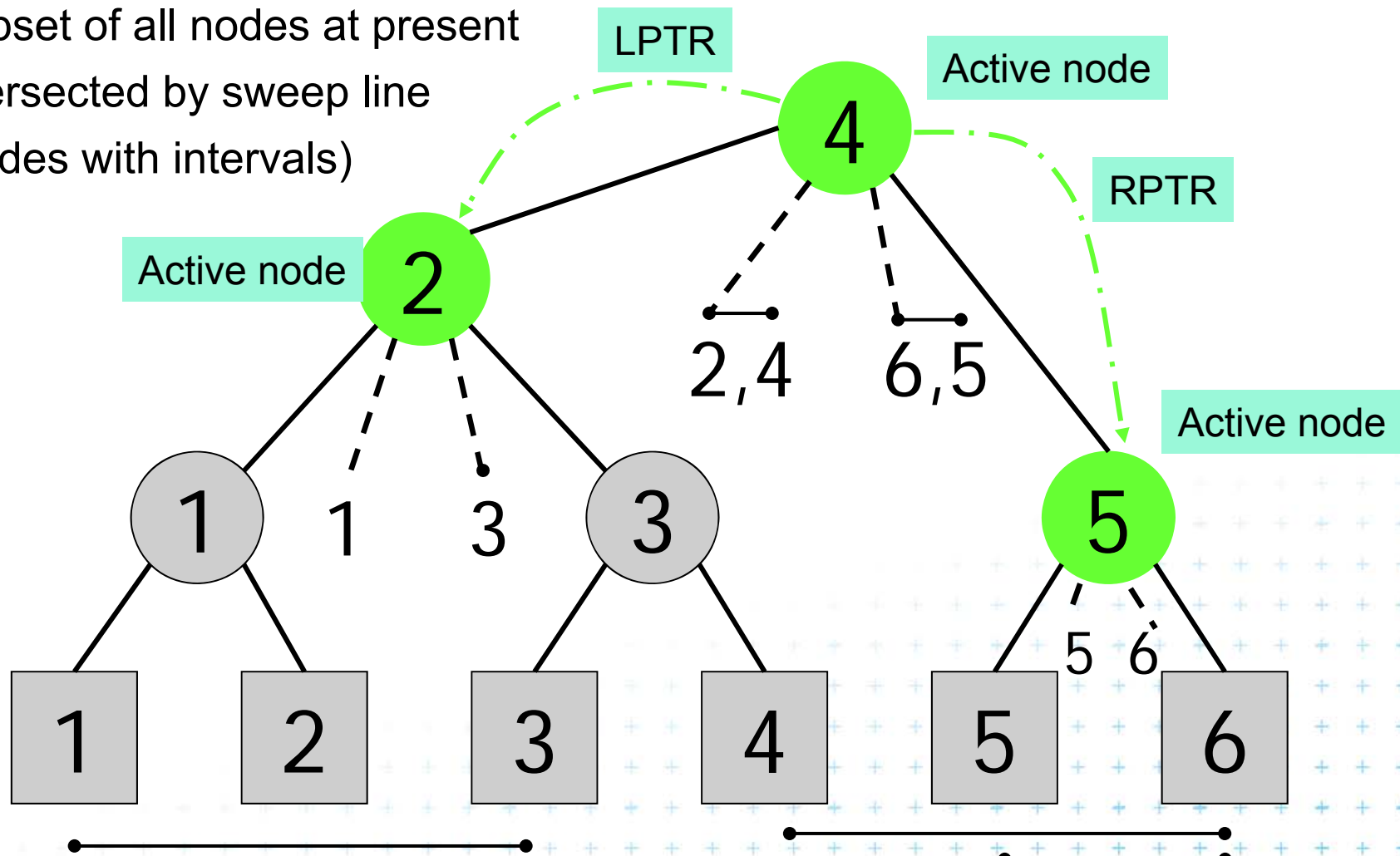



Query = sweep and report intersections

RectangleIntersections(S)

Input: Set S of rectangles

Output: Intersected rectangle pairs

1. Preprocess(S) // create the interval tree T (for y-coords)
// and event queue Q (for x-coords)
2. **while** ($Q \neq \emptyset$) do
3. Get next entry (x_i, y_{il}, y_{ir}, t) from Q // $t = \{ \text{left} \mid \text{right} \}$
4. **if** ($t = \text{left}$) // left edge 
5. a) **QueryInterval** ($y_{il}, y_{ir}, \text{root}(T)$) // report intersections
6. b) **InsertInterval** ($y_{il}, y_{ir}, \text{root}(T)$) // insert new interval
7. **else** // right edge 
8. c) **DeleteInterval** ($y_{il}, y_{ir}, \text{root}(T)$)

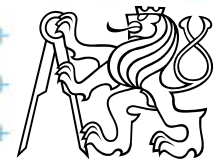

Preprocessing

Preprocess(S)

Input: Set S of rectangles

Output: Primary structure of the interval tree T and the event queue Q

1. $T = \text{PrimaryTree}(S)$ // Construct the static primary structure
// of the interval tree -> sweep line STATUS T
2. // Init event queue Q with vertical rectangle edges in ascending order.
// Put the left edges with the same x ahead of right ones.
3. for i = 1 to n
4. insert((x_{il} , y_{il} , y_{ir} , left), Q) // left edges of i-th rectangle
5. insert((x_{ir} , y_{il} , y_{ir} , right), Q) // right edges



Interval tree – primary structure construction

PrimaryTree(S)

Input: Set S of rectangles

Output: Primary structure of an interval tree T

1. $S_y = \text{Sort endpoints of all segments in } S \text{ according to } y\text{-coordinate}$
2. $T = \text{BST}(S_y)$
3. **return** T

BST(S_y)

1. **if**($|S_y| = 0$) **return** null
2. $yMed = \text{median of } S_y$
3. $L = \text{endpoints } p_y \leq yMed$
4. $R = \text{endpoints } p_y > yMed$
5. $t = \text{new IntervalTreeNode}(yMed)$
6. $t.\text{left} = \text{BST}(L)$
7. $t.\text{right} = \text{BST}(R)$
8. **return** t



Interval tree – search the intersections

QueryInterval (b, e, T)

Input: Interval of the edge and current tree T

Output: Report the rectangles that intersect $[b, e]$

1. **if** ($T = \text{null}$) **return**
2. $i=0$; **if** ($b < H(v) < e$) // forks at node b
3. **while** ($MR(v).[i] \geq b$) && ($i < \text{Count}(v)$) .. Report all intervals in M
4. ReportIntersection; $i++$
5. QueryInterval($b, e, T.LPTR$)
6. QueryInterval($b, e, T.RPTR$)
7. **else if** ($H(v) \leq b < e$) // search RIGHT
8. **while** ($MR(v).[i] \geq b$) && ($i < \text{Count}(v)$)
9. ReportIntersection; $i++$
10. QueryInterval($b, e, T.RPTR$)
11. **else** // $b < e \leq H(v)$ //search LEFT
12. **while** ($ML(v).[i] \leq e$)
13. ReportIntersection; $i++$
14. QueryInterval($b, e, T.LPTR$)

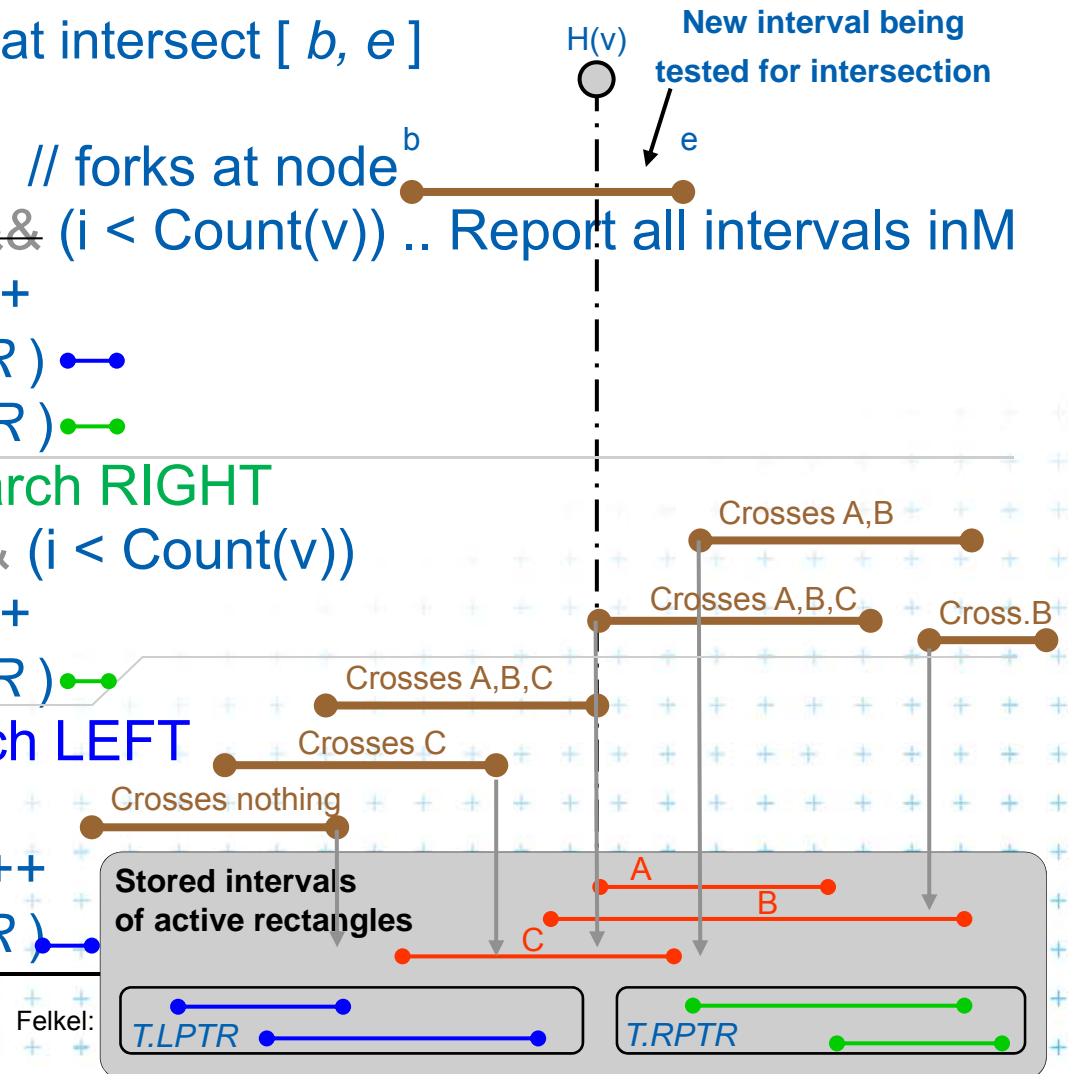

Interval tree - interval insertion

InsertInterval (b, e, T)

Input: Interval $[b,e]$ and interval tree T

Output: T after insertion of the interval

1. $v = \text{root}(T)$
2. **while**($v \neq \text{null}$) // find the fork node
3. **if** ($H(v) < b < e$)
4. $v = v.\text{right}$ // continue right
5. **else if** ($b < e < H(v)$)
6. $v = v.\text{left}$ // continue left
7. **else** // $b \leq H(v) \leq e$ // insert interval
8. set v node to *active*
9. connect LPTR resp. RPTR to its parent
10. insert $[b,e]$ into list $ML(v)$ – sorted in ascending order of b 's
11. insert $[b,e]$ into list $MR(v)$ – sorted in descending order of e 's
12. break
13. **endwhile**
14. **return** T

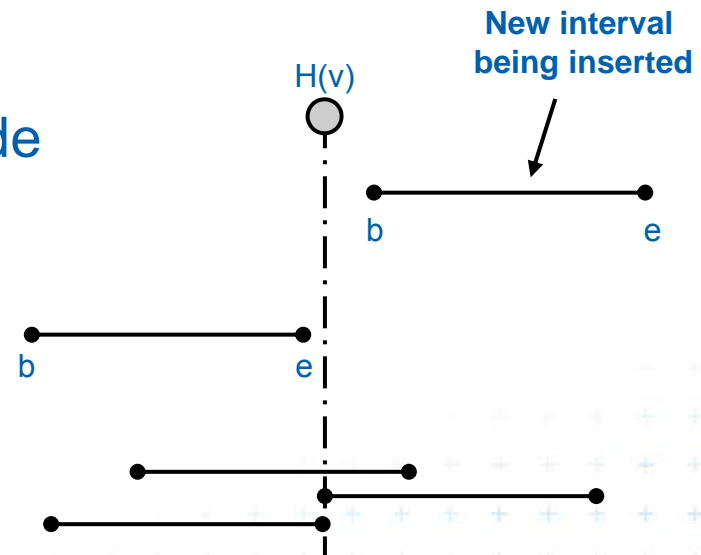

+

DCGI



Example 1



Example 1 – static tree on endpoints

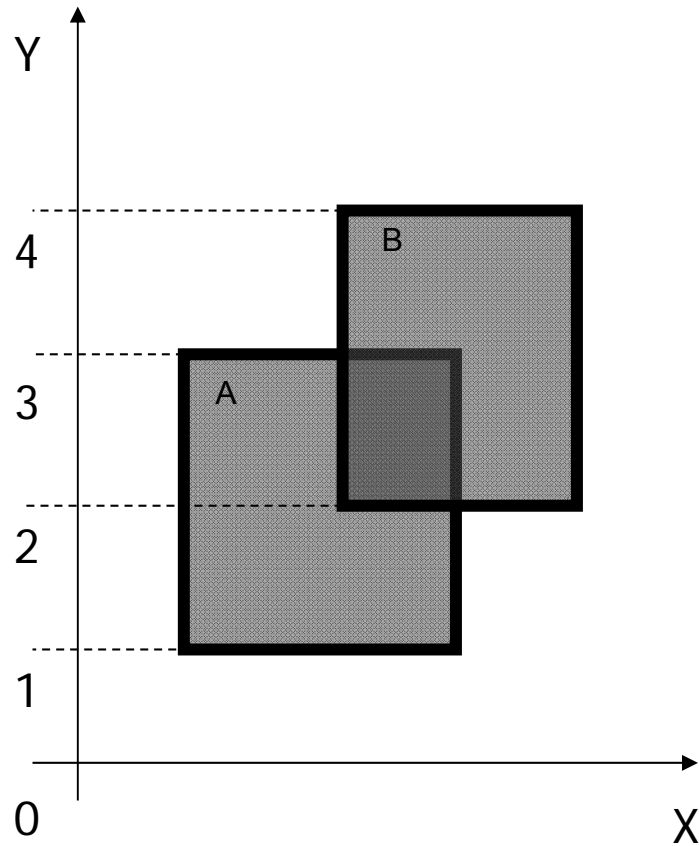

$H(v)$ – value of node v

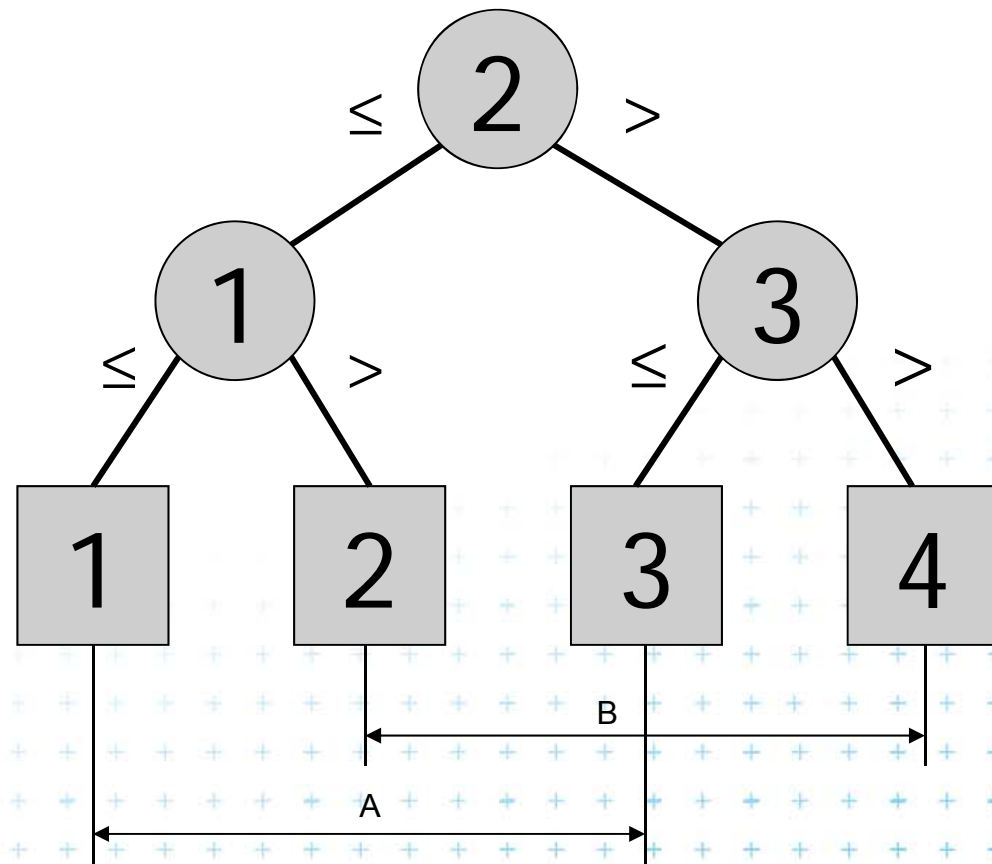



[Drtina]

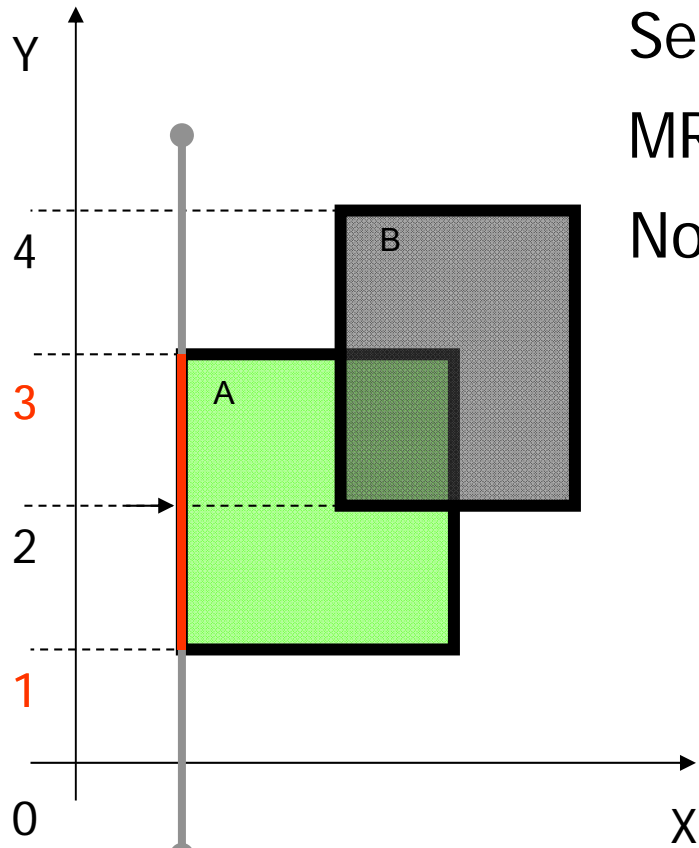

Interval insertion [1,3] a) Query Interval



-  Active rectangle
-  Current node
-  Active node

Search $MR(v)$ or $ML(v)$: $\leftarrow b < H(v) < e$
 $MR(v)$ is empty
 No active sons, stop

1 < 2 < 3

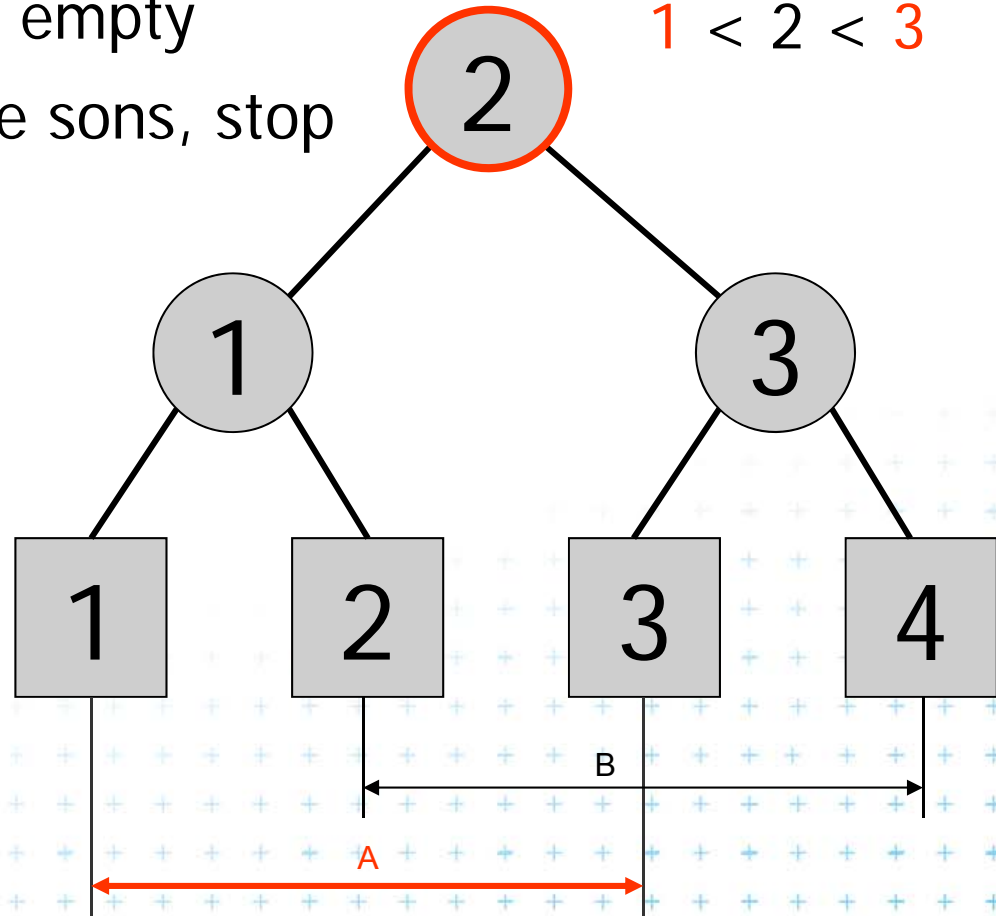



[Drtina]

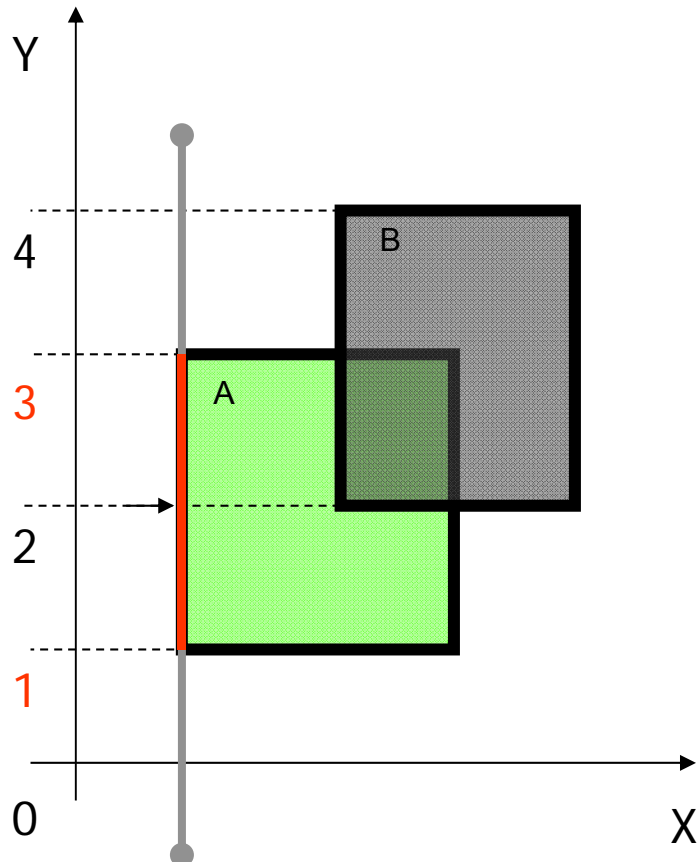

Interval insertion [1,3] b) Insert Interval



-  Active rectangle
-  Current node
-  Active node

$$b \leq H(v) \leq e$$

$$? \ 1 \leq 2 \leq 3 \ ?$$

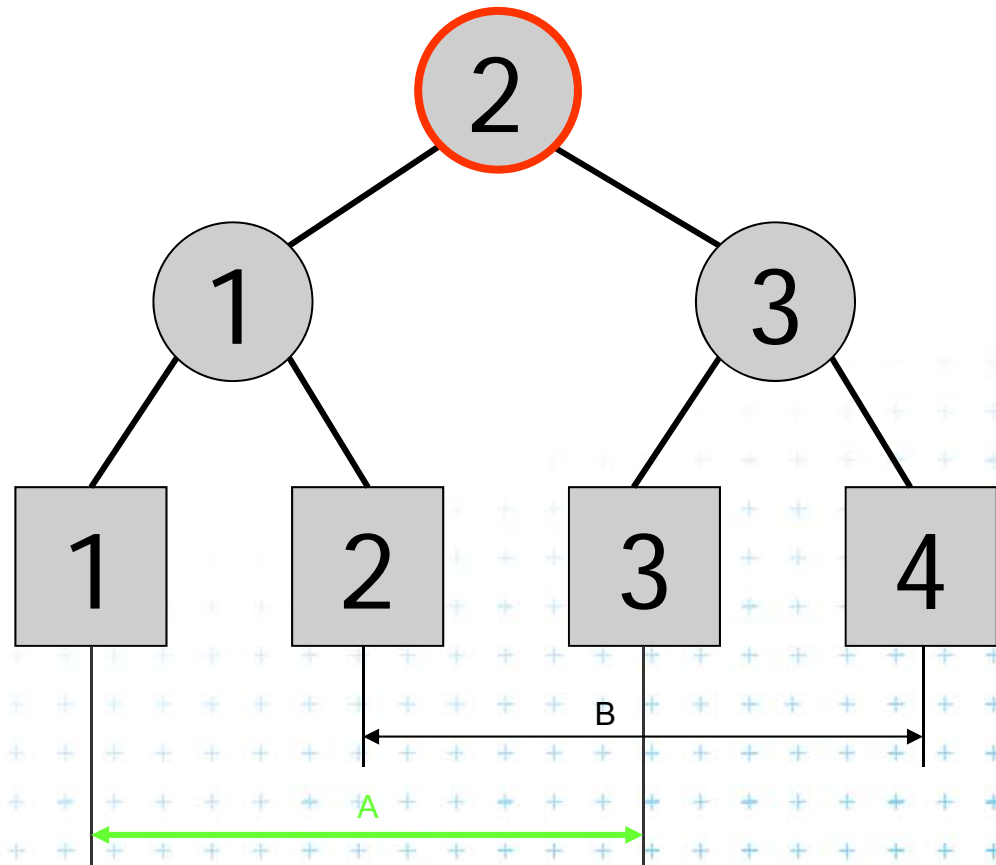



[Drtina]

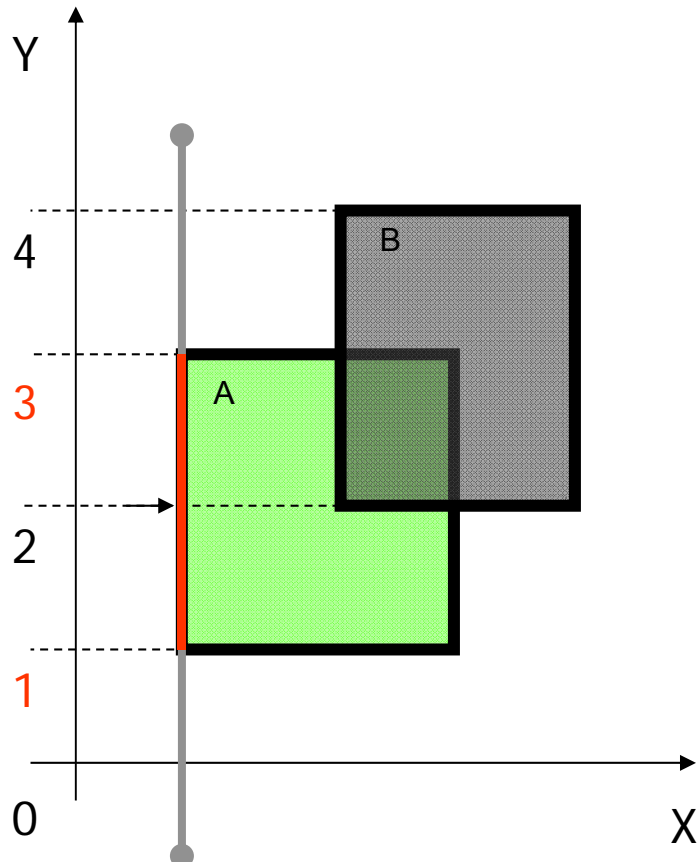

Interval insertion [1,3] b) Insert Interval



-  Active rectangle
-  Current node
-  Active node

$$b \leq H(v) \leq e$$

$$1 \leq 2 \leq 3$$

fork
=> to lists

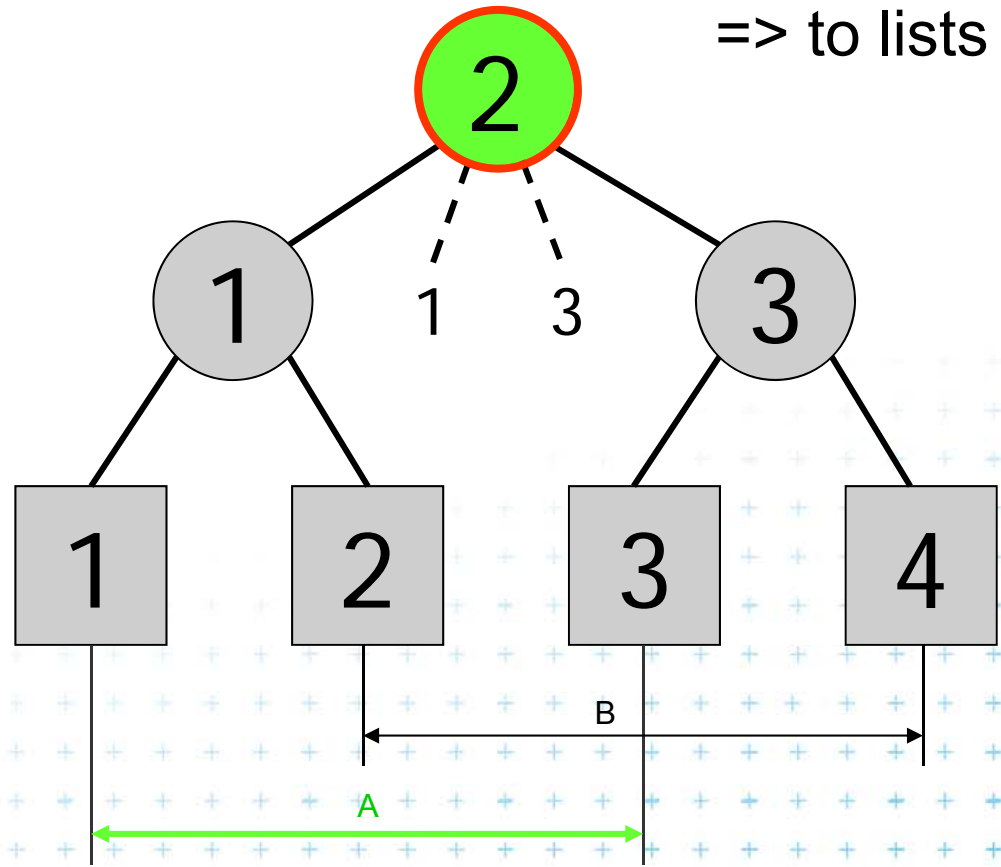



[Drtina]

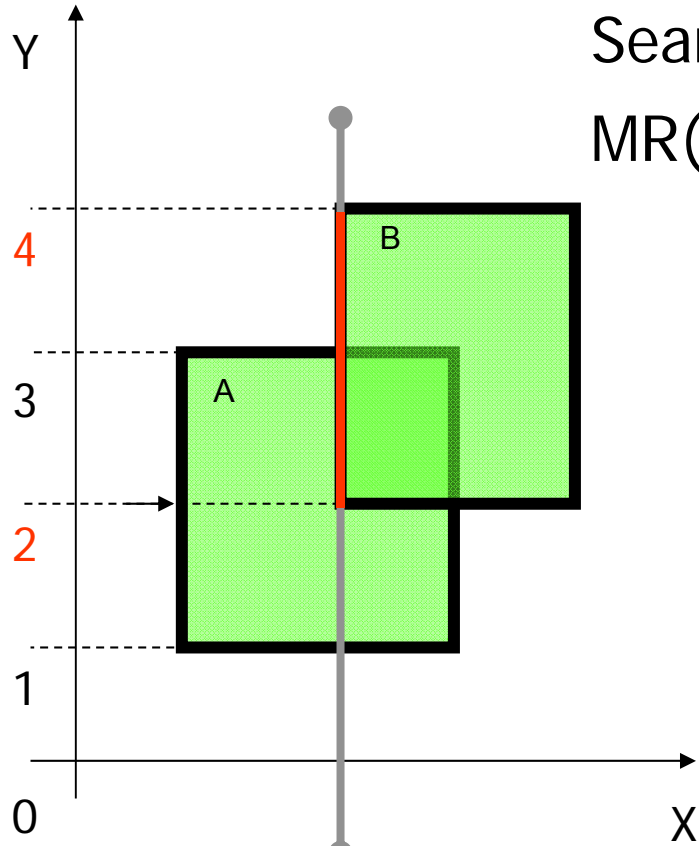

Interval insertion [2,4] a) Query Interval



-  Active rectangle
-  Current node
-  Active node

Search MR(v) only: $\leftarrow H(v) \leq b < e$

MR(v)[1] = 3 \geq 2?

2 \leq 2 < 4

=> intersection

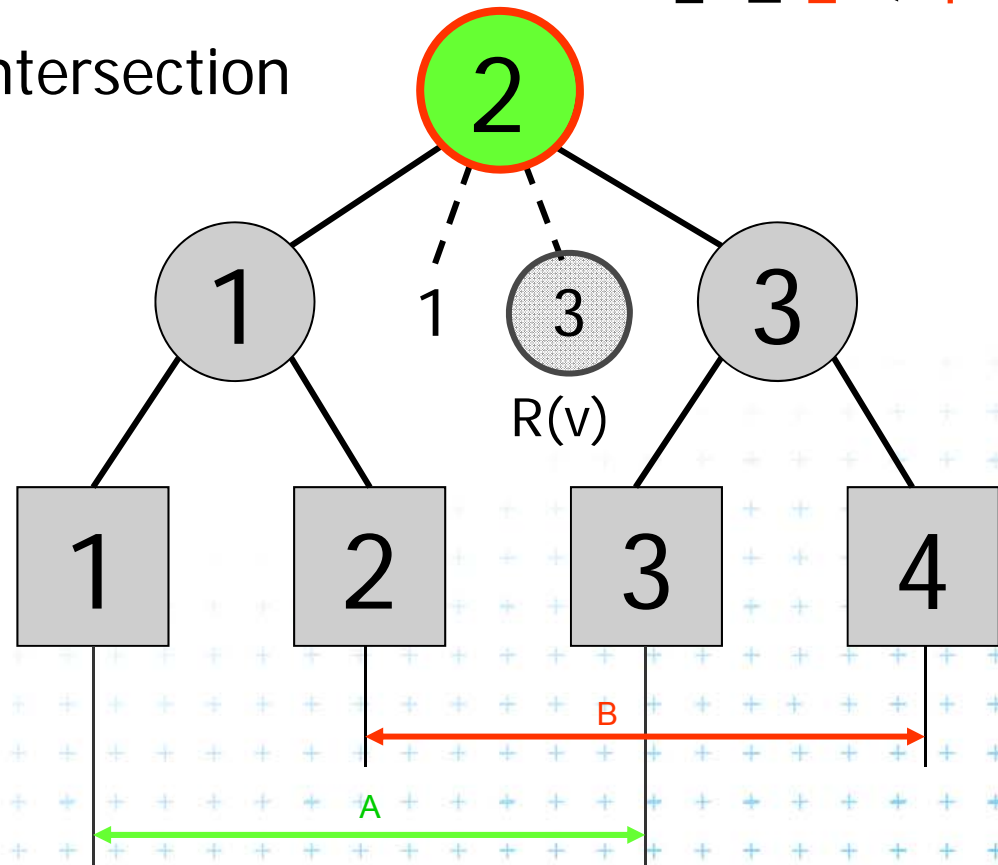



[Drtina]

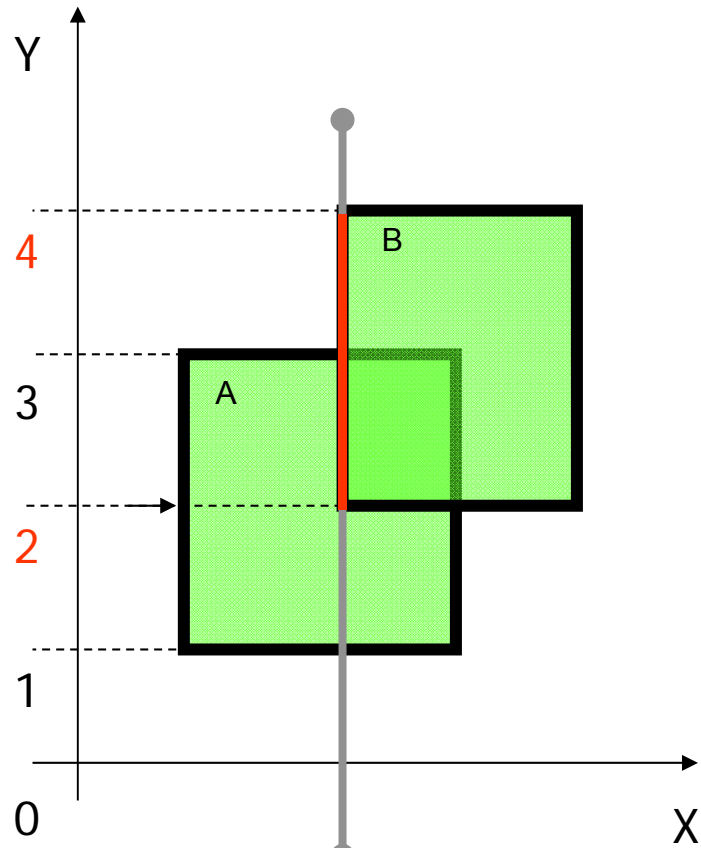

Interval insertion [2,4] b) Insert Interval



-  Active rectangle
-  Current node
-  Active node

$$b \leq H(v) \leq e$$

$$2 \leq 2 \leq 4$$

fork
=> to lists

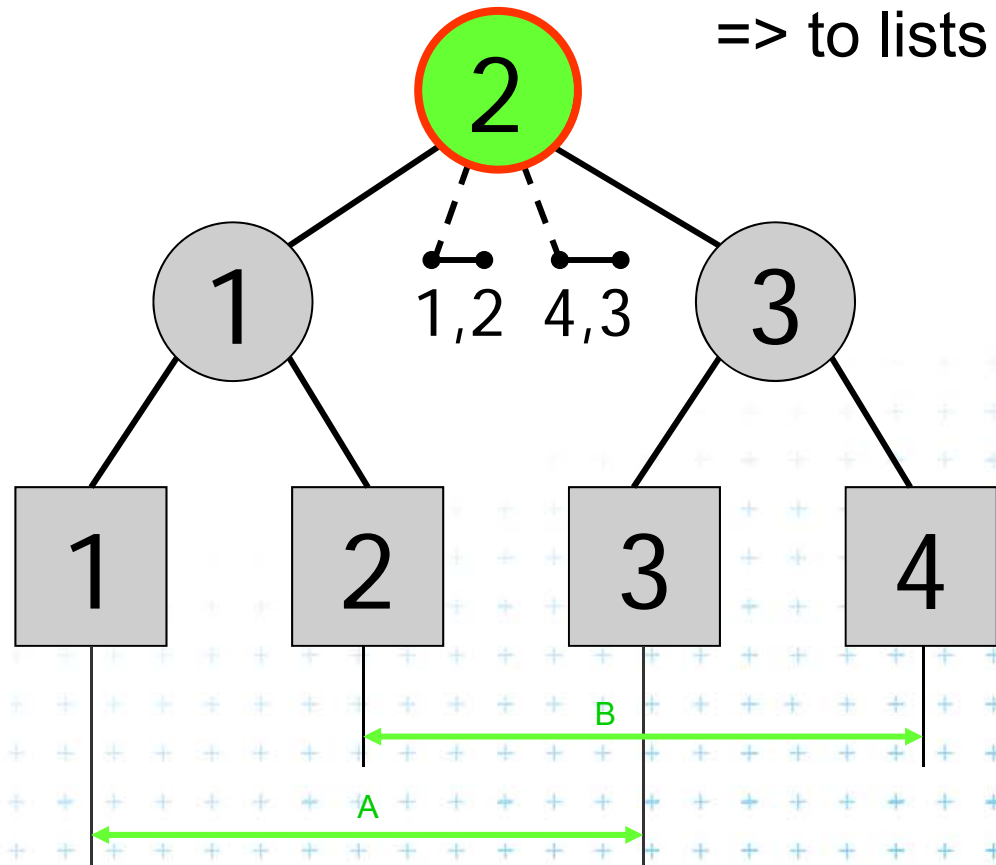



[Drtina]

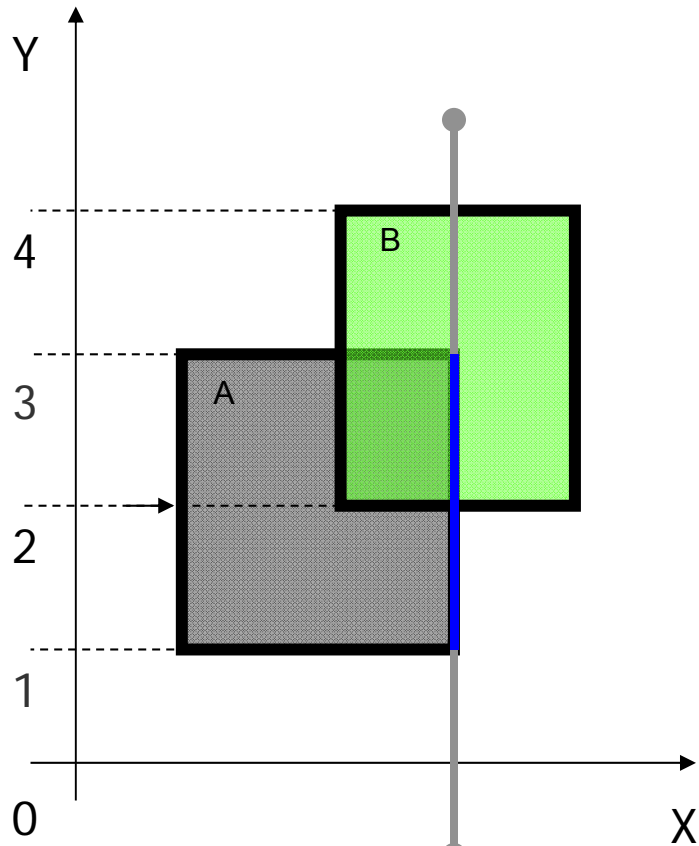

Interval delete [1,3]



-  Active rectangle
-  Current node
-  Active node

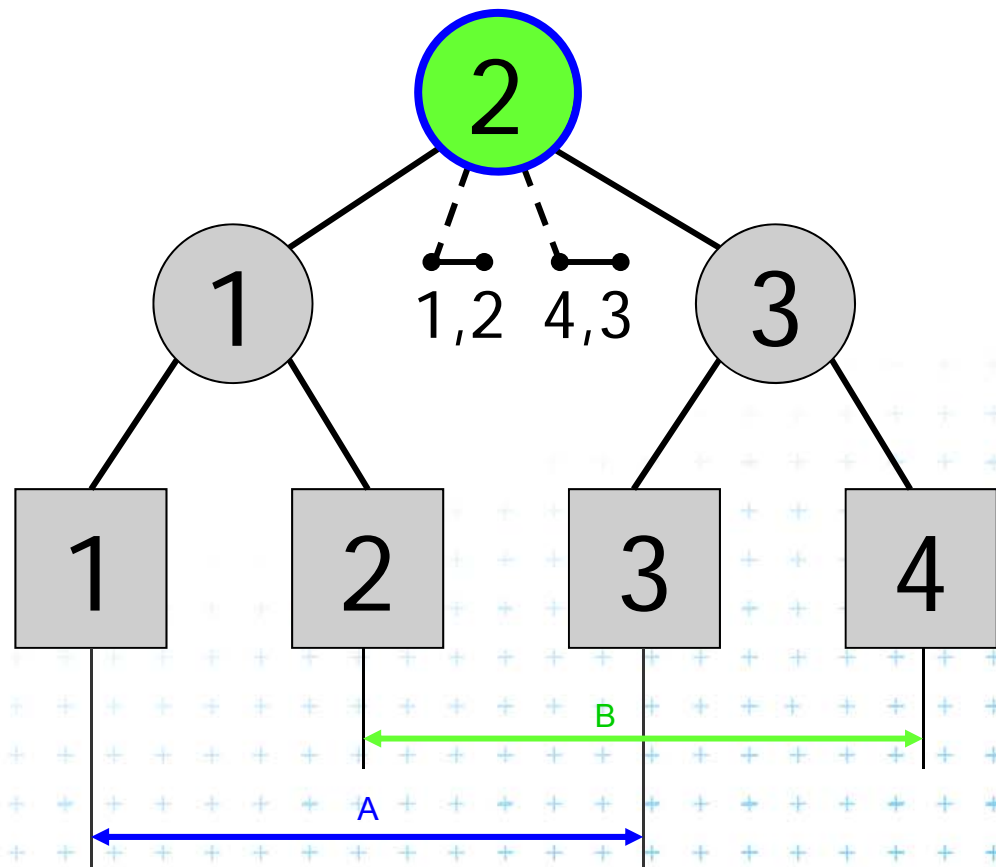



[Drtina]

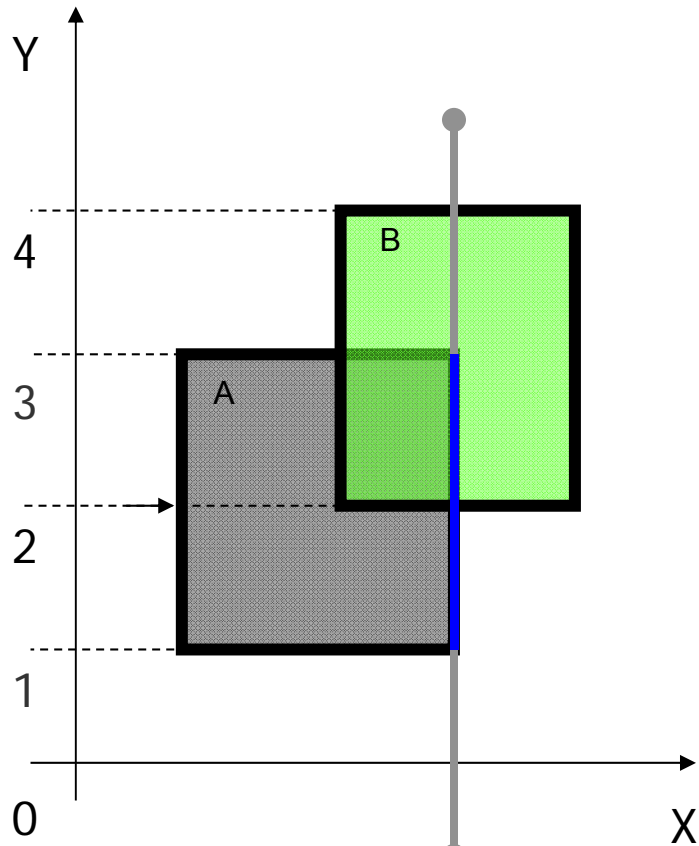

Interval delete [1,3]



-  Active rectangle
-  Current node
-  Active node

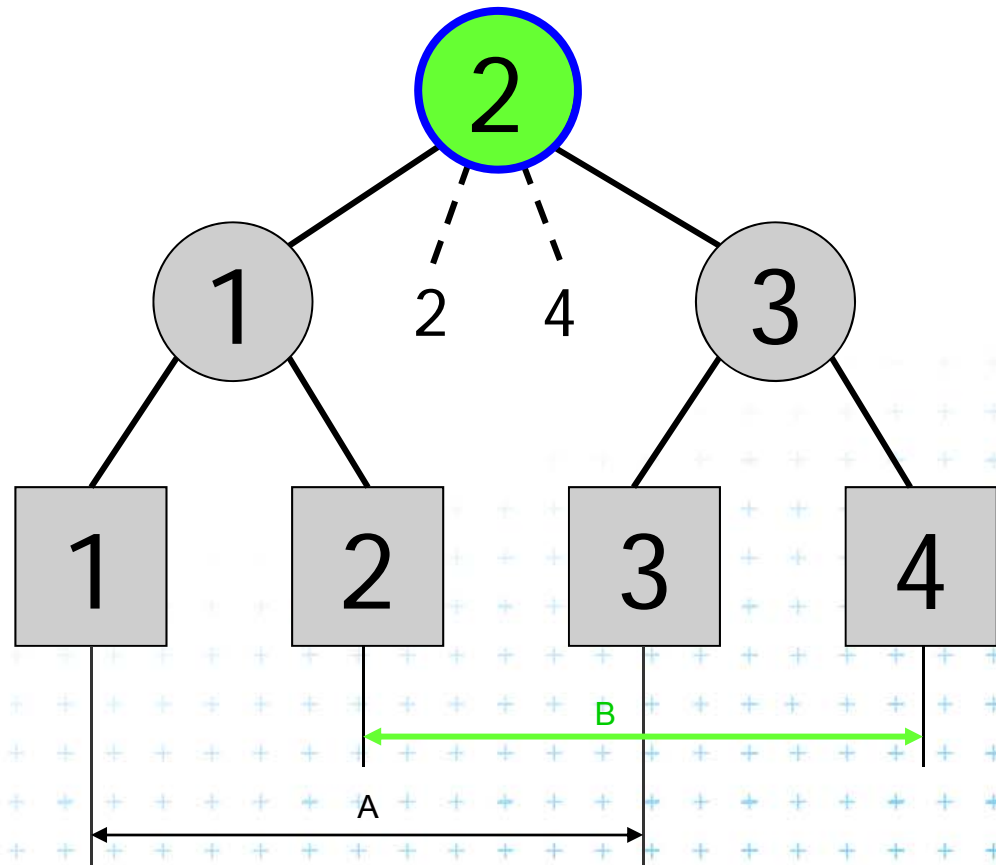



[Drtina]

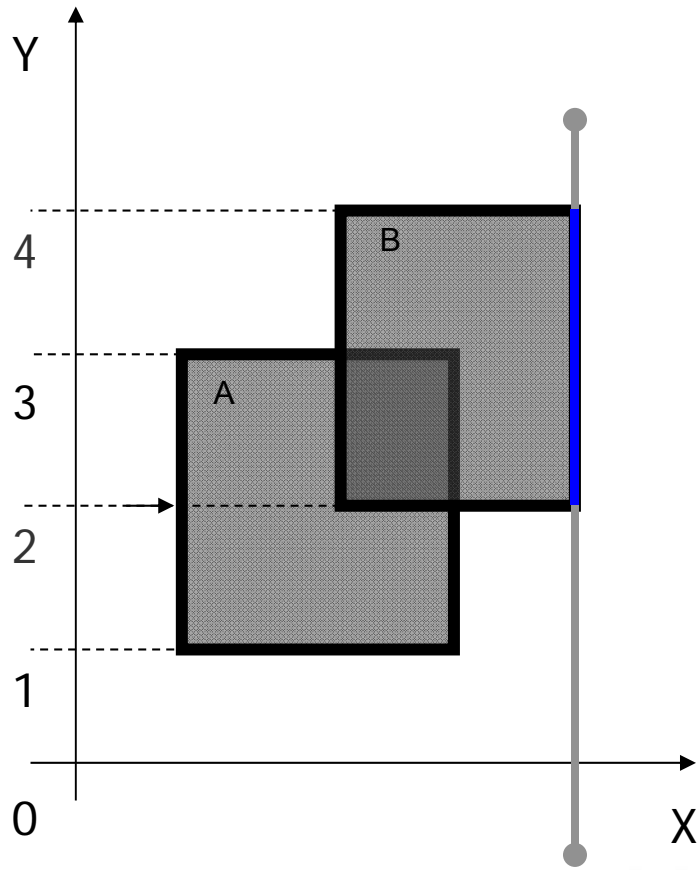

Interval delete [2,4]



-  Active rectangle
-  Current node
-  Active node

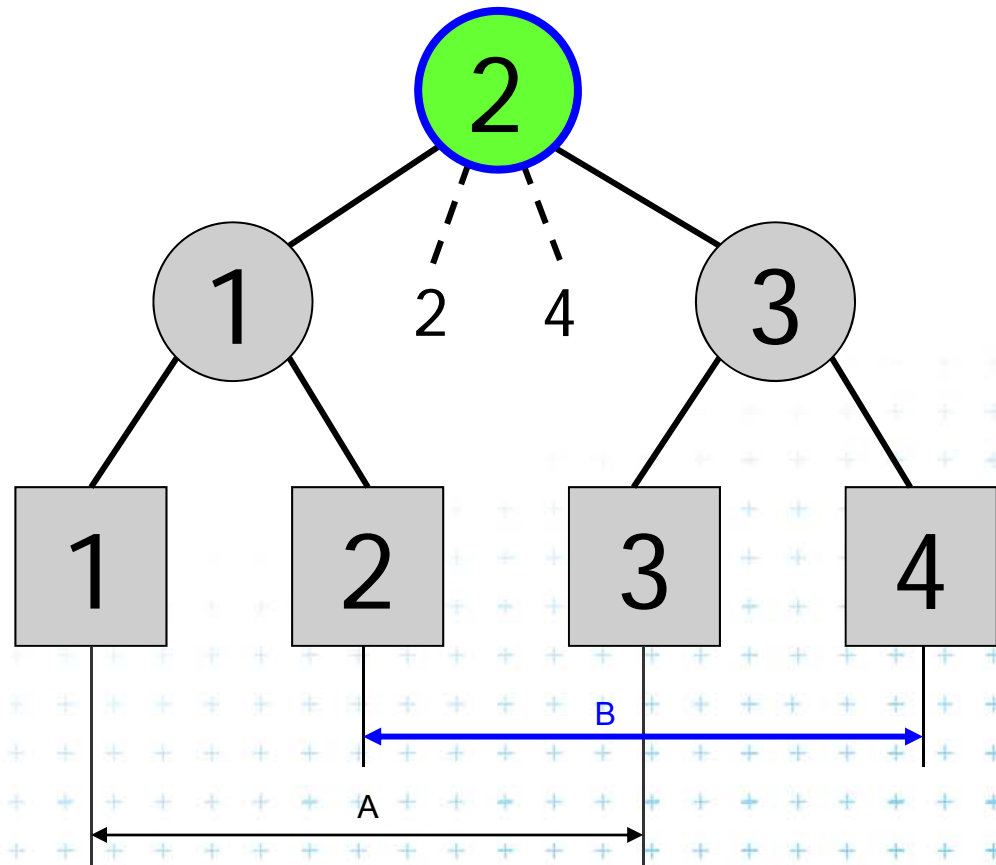

[Drtina]



Interval delete [2,4]

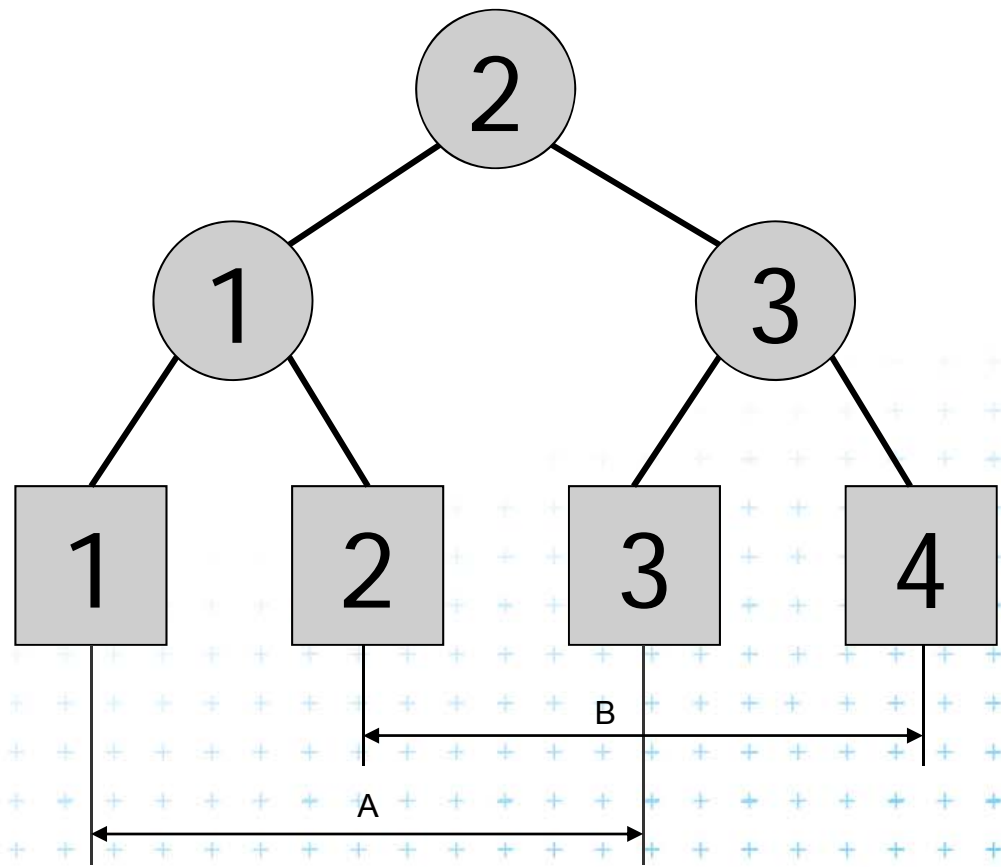
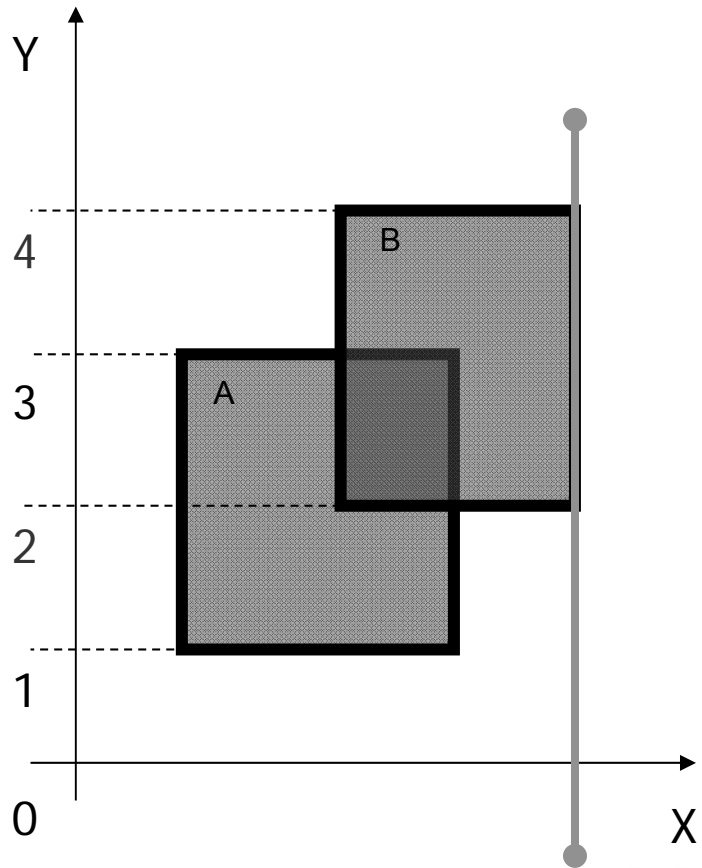

[Drtina]

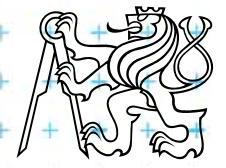

Example 2

RectangleIntersections(S) // this is copy of the slide before
Input: Set S of rectangles // just to remember the algorithm
Output: Intersected rectangle pairs

1. Preprocess(S) // create the interval tree T and event queue Q
2. **while** (Q $\neq \emptyset$) do
3. Get next entry $(x_{il}, y_{il}, y_{ir}, t)$ from Q // $t = \{ \text{left} \mid \text{right} \}$
4. **if** ($t = \text{left}$) // left edge
5. a) **QueryInterval** ($y_{il}, y_{ir}, \text{root}(T)$) // report intersections
6. b) **InsertInterval** ($y_{il}, y_{ir}, \text{root}(T)$) // insert new interval
7. **else** // right edge
8. c) **DeleteInterval** ($y_{il}, y_{ir}, \text{root}(T)$)



Example 2

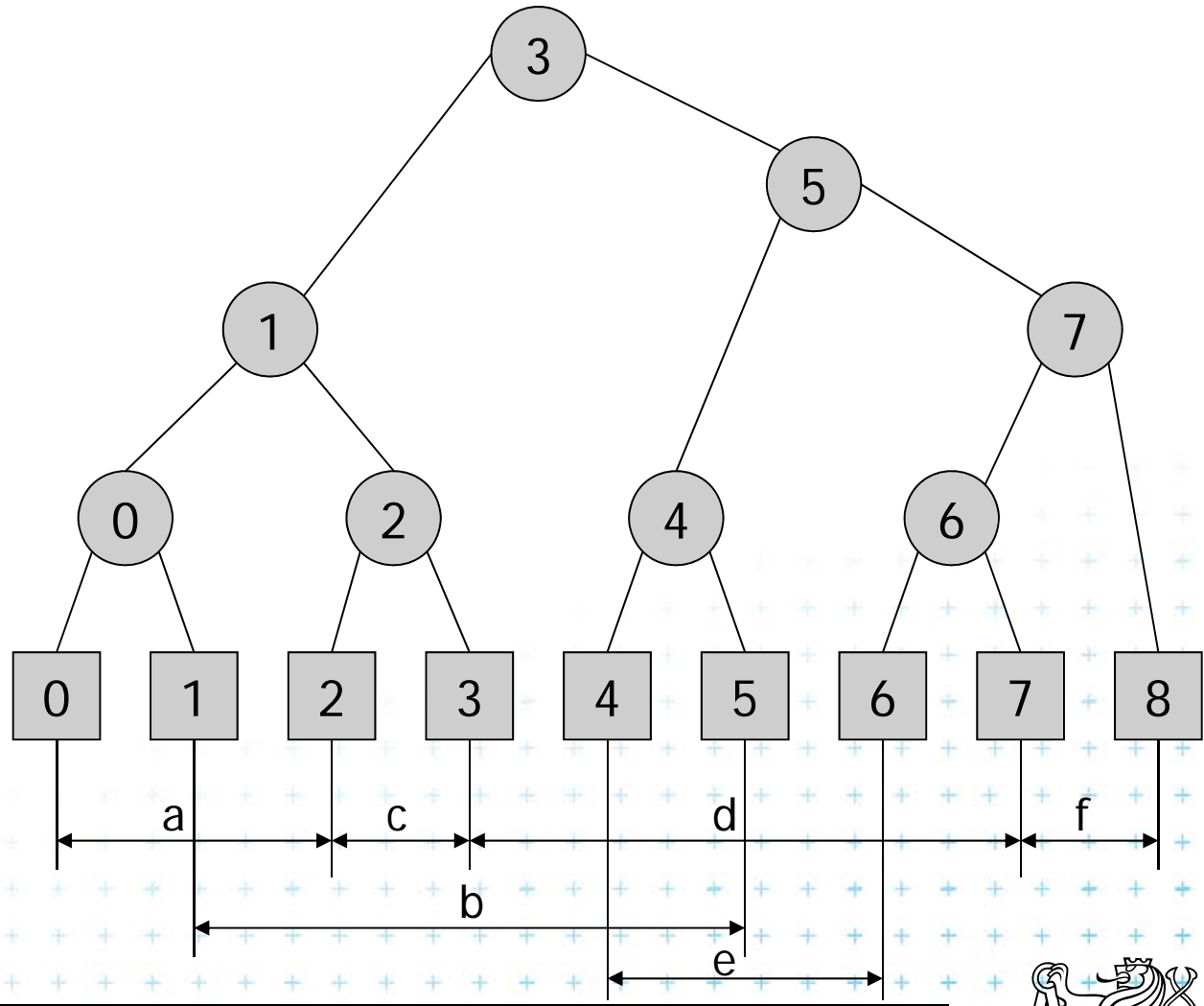
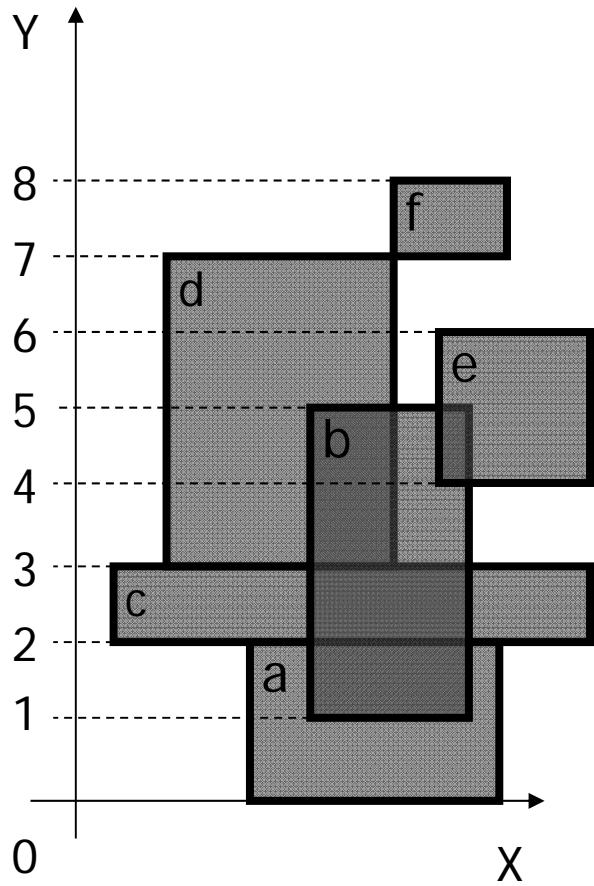

Insert [2,3] – empty => b) Insert Interval

$$b \leq H(v) \leq e$$

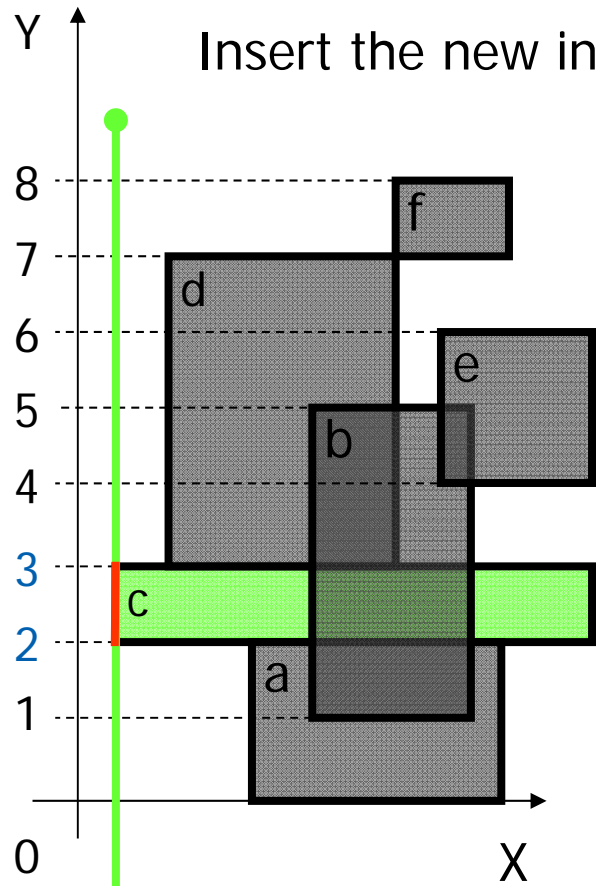

Insert the new interval to secondary lists

? $2 \leq 3 \leq 3$?

fork node => active
=> to lists

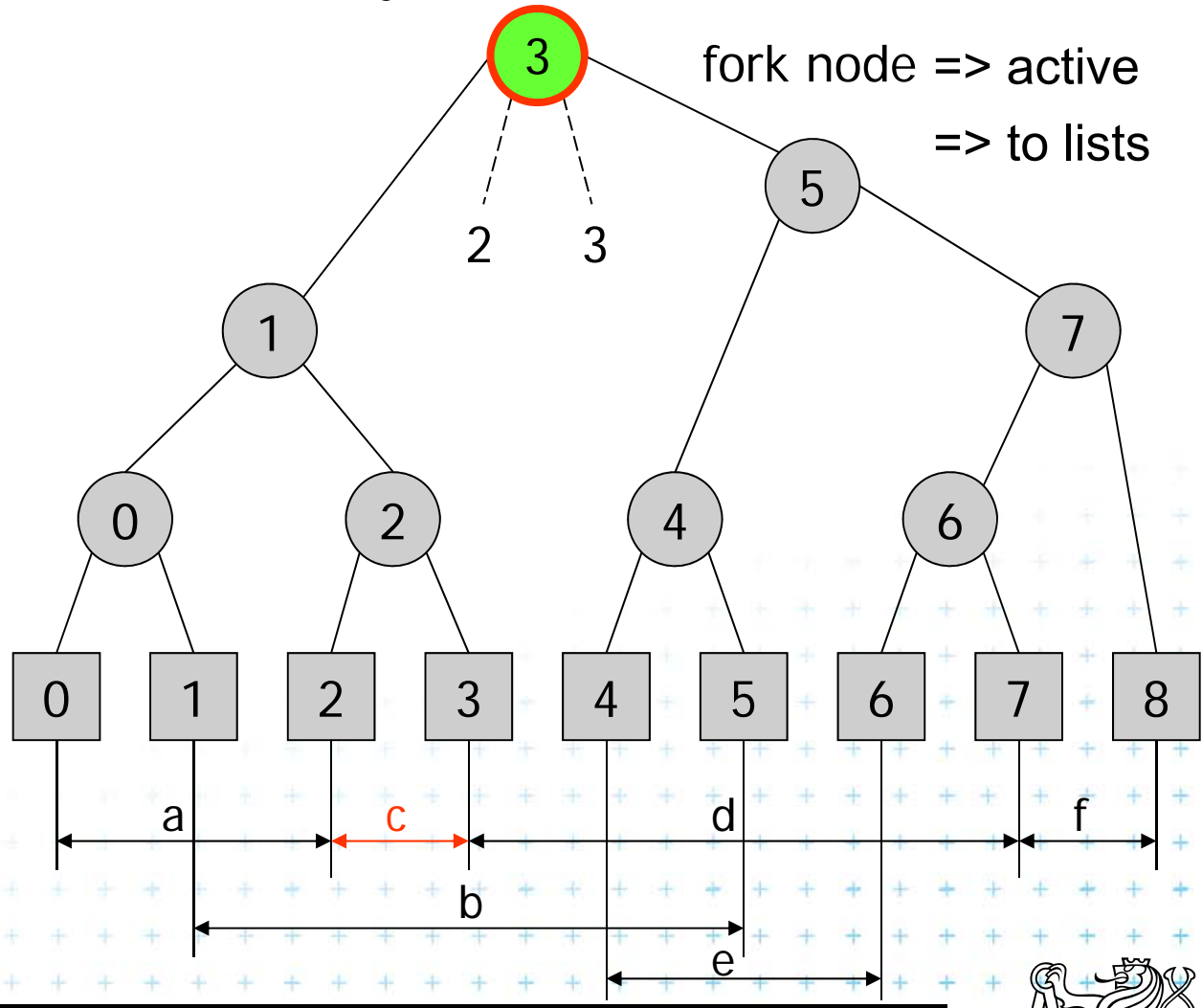

- Active rectangle
- Current node
- Active node



Insert [3,7] a) Query Interval

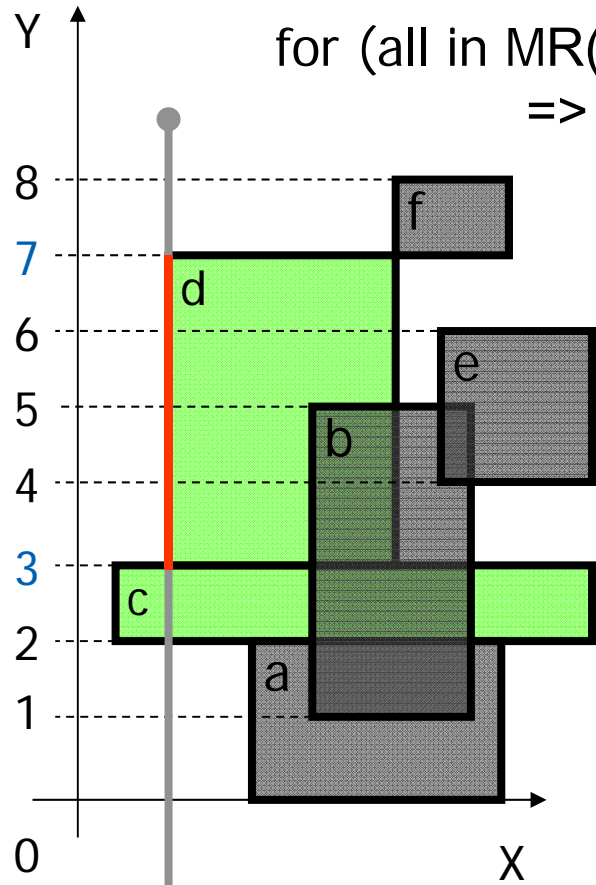

$$H(v) \leq b < e$$

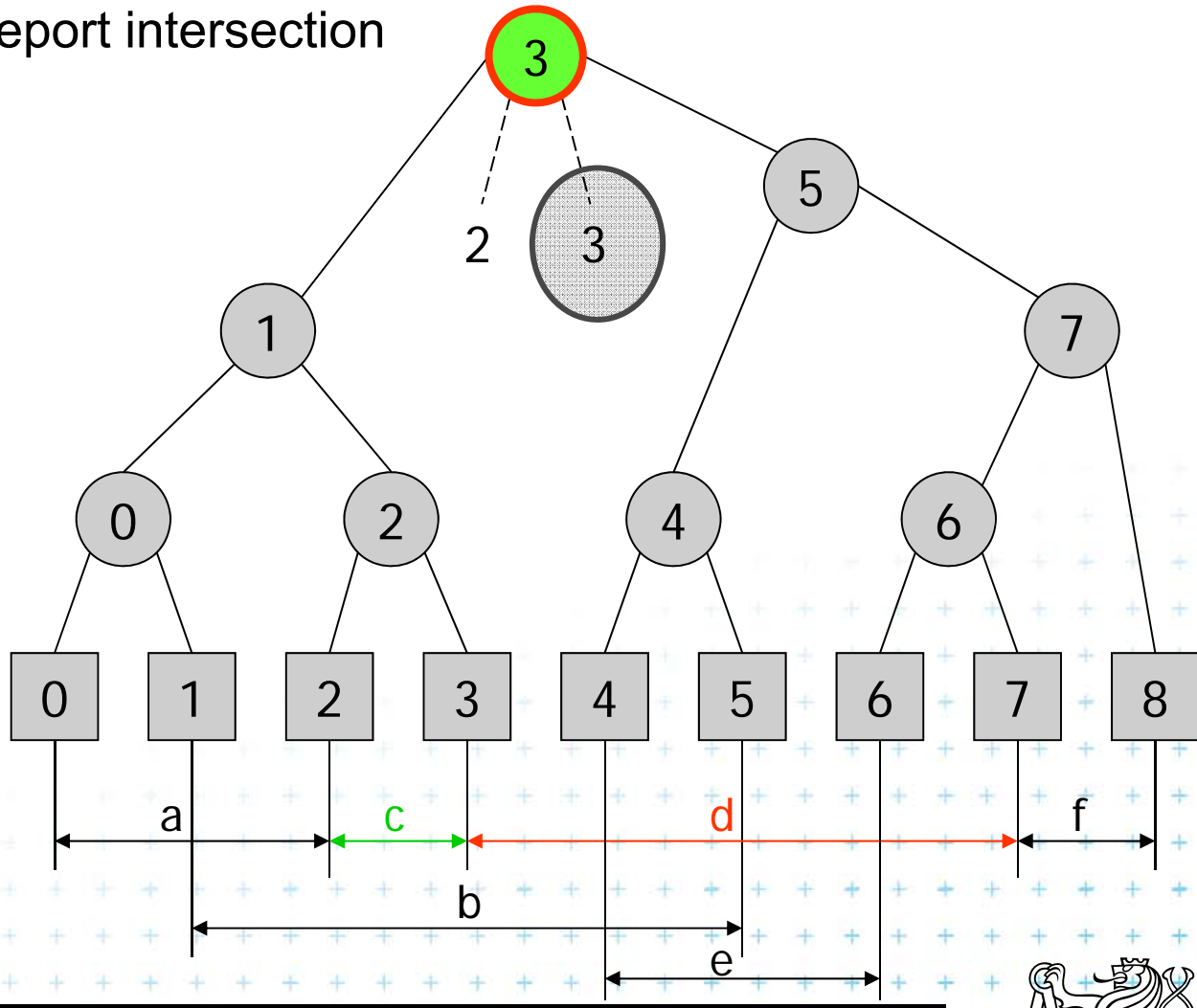

for (all in MR(v)) test $MR(v)[i] \geq 3$
 \Rightarrow report intersection

? $3 \leq 3 < 7$?



-  Active rectangle
-  Current node
-  Active node



Insert [3,7] b) Insert Interval

$$b \leq H(v) \leq e$$

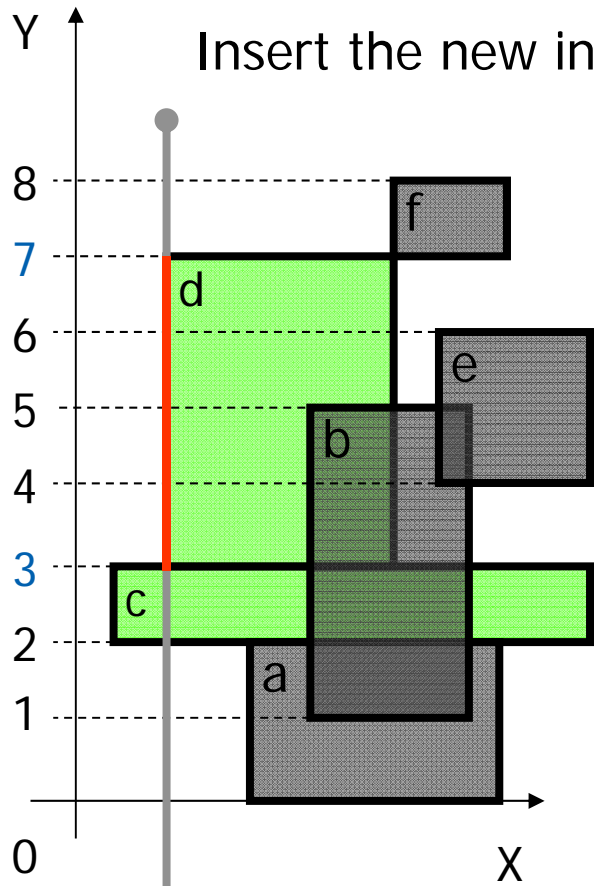

Insert the new interval to secondary lists

$$3 \leq 3 \leq 7$$

fork node => active
=> to lists

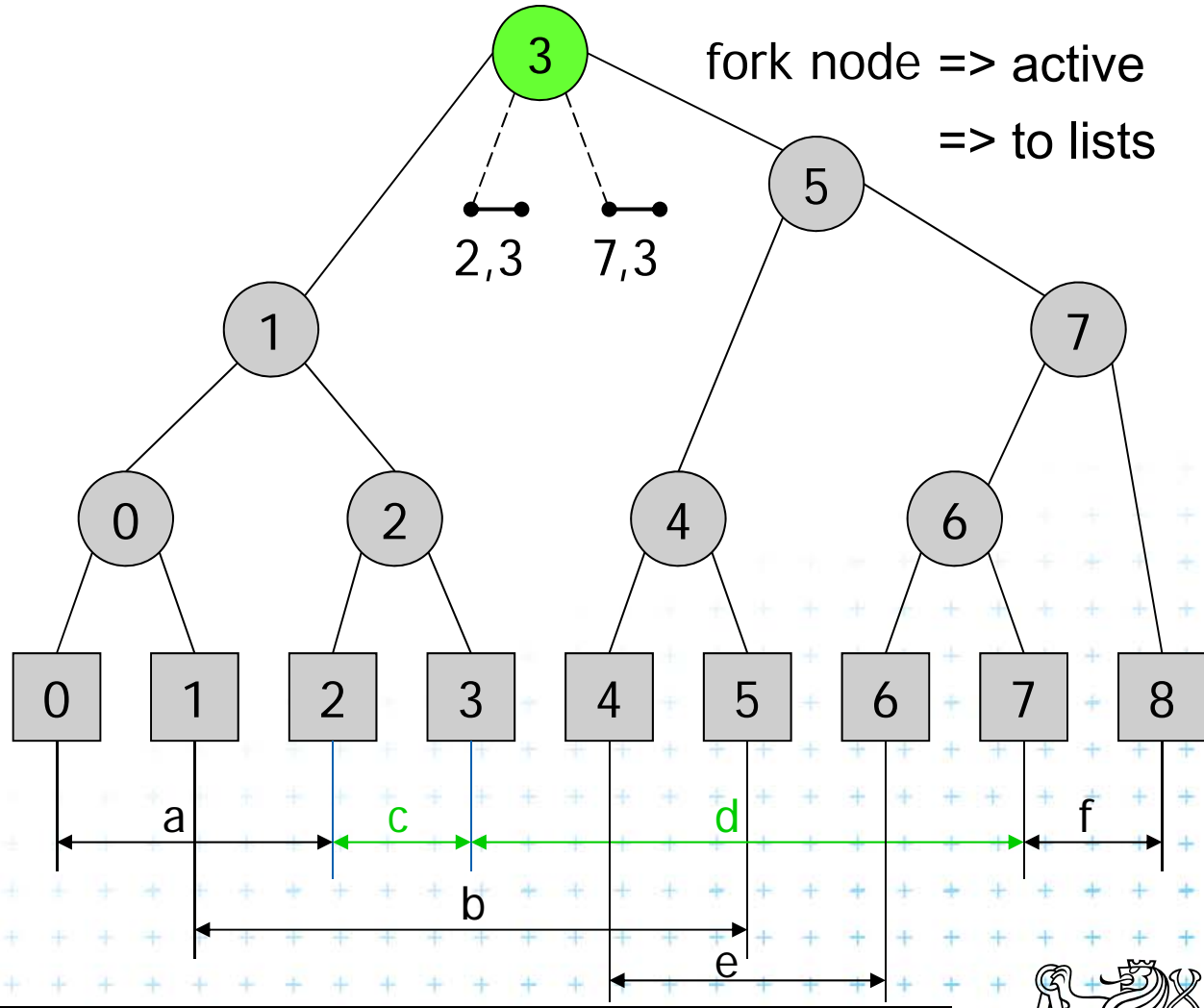

- Active rectangle
- Current node
- Active node



Insert [0,2] a) Query Interval

$$b < e \leq H(v)$$

$$? 0 < 2 \leq 3 ?$$

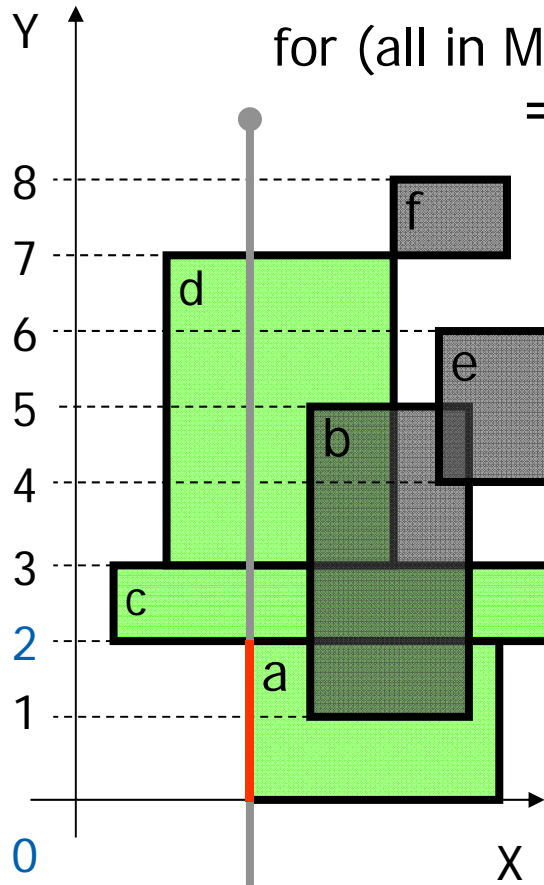

for (all in ML(v)) test $ML(v).[i] \leq 2$
 \Rightarrow report intersection c
 go left, nil, stop

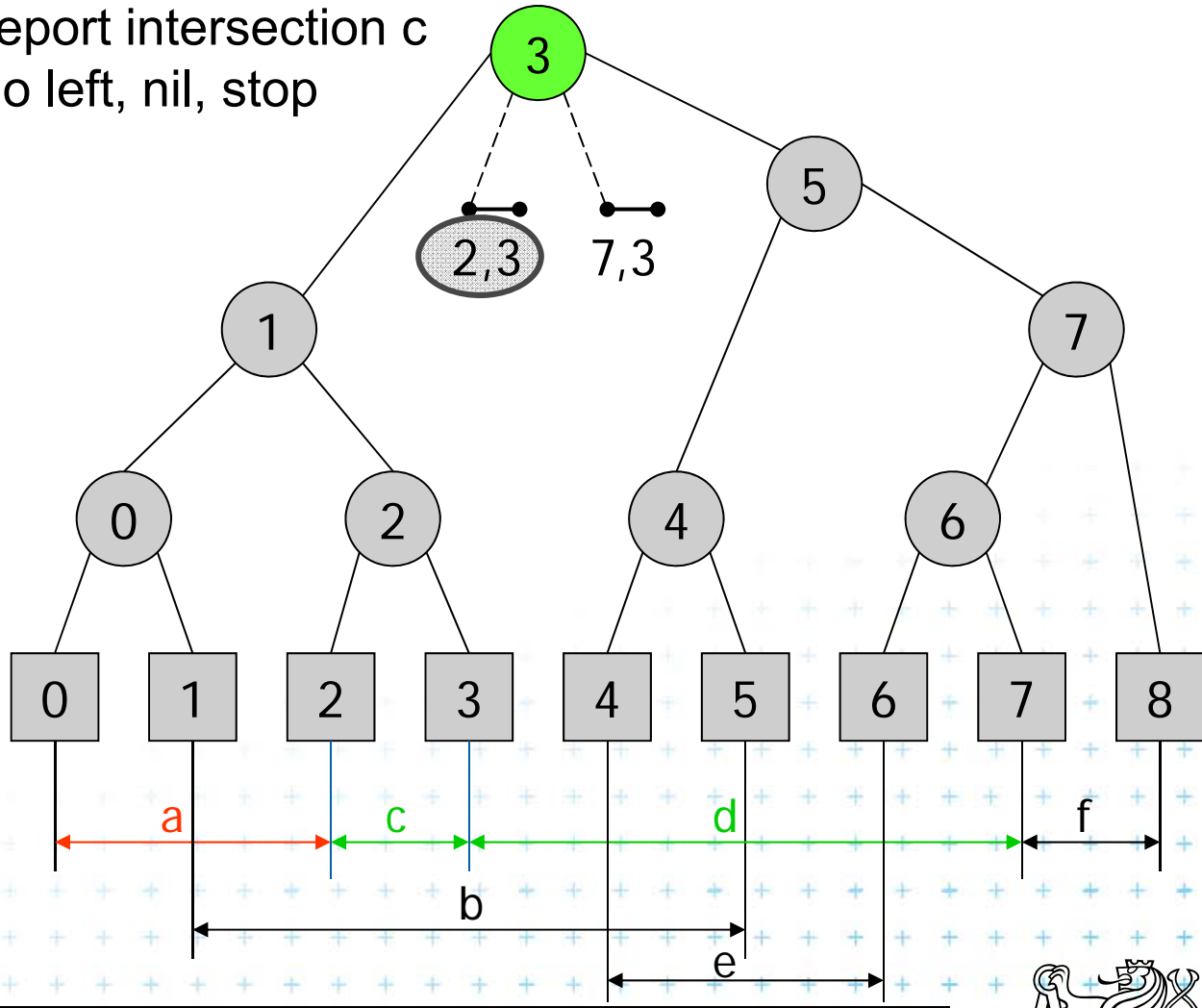



Insert [0,2] b) Insert Interval 1/2

$$b < e < H(v)$$

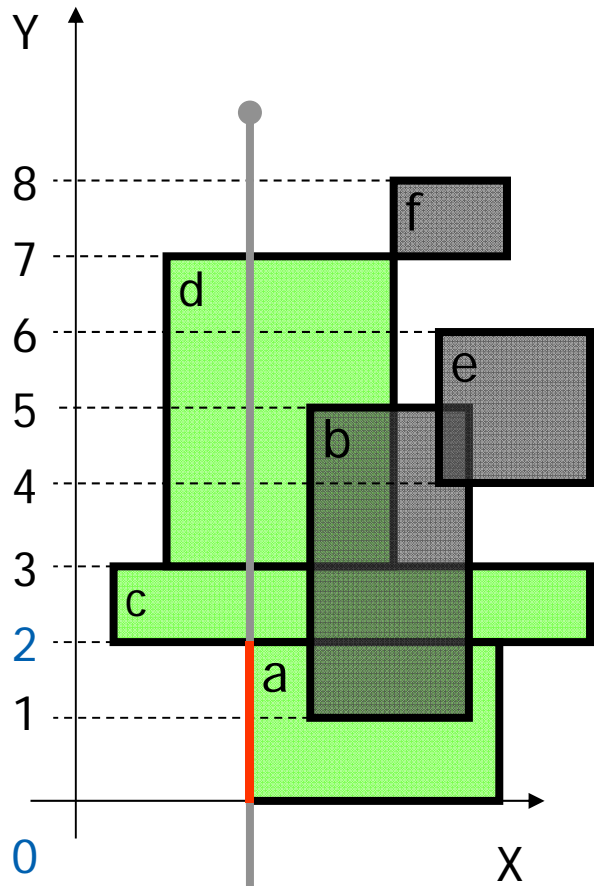
? $0 < 2 < 3$?
=> insert left



-  Active rectangle
-  Current node
-  Active node

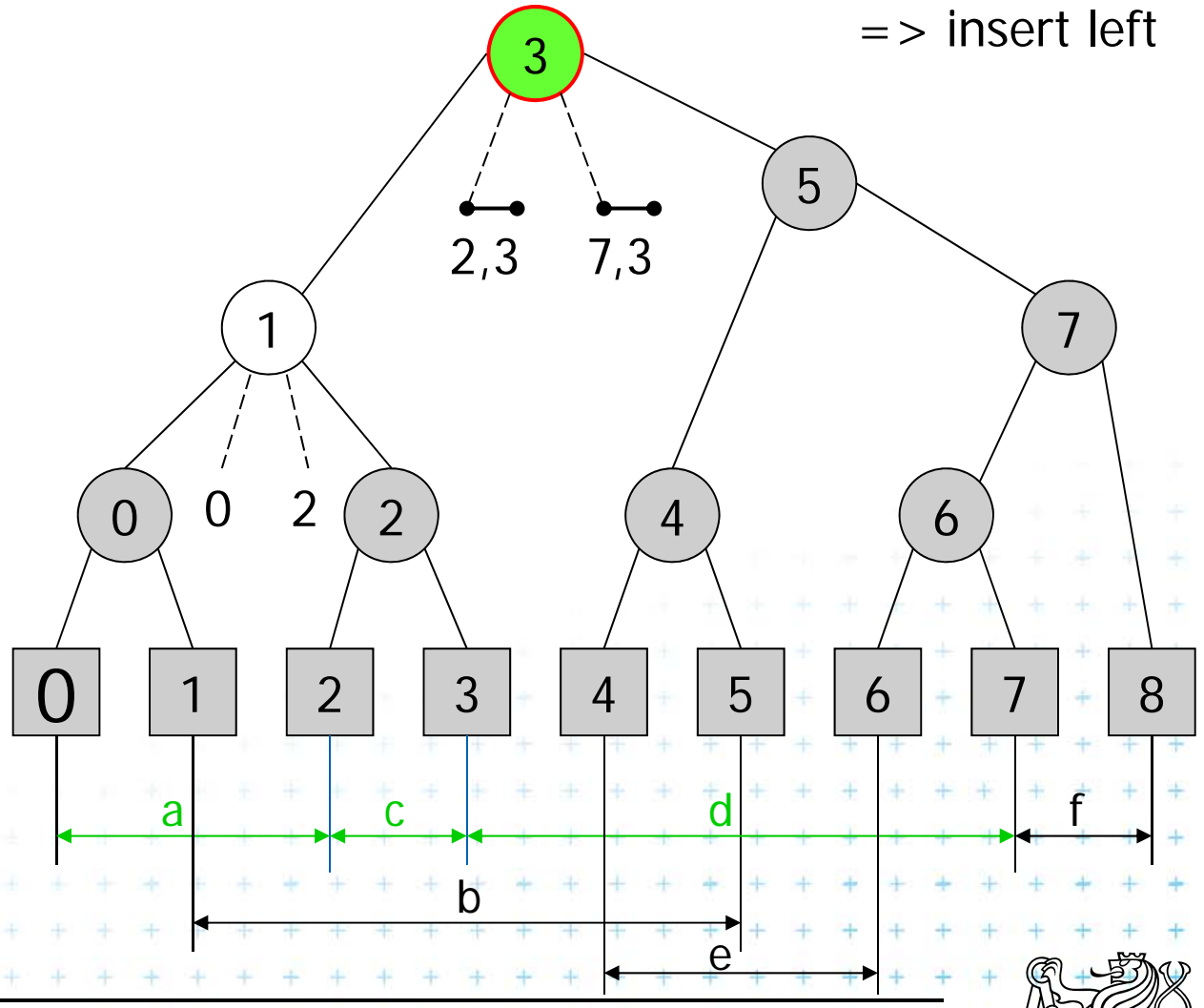

Insert [0,2] b) Insert Interval 2/2

$$b \leq H(v) \leq e$$

$$? 0 \leq 1 \leq 2 ?$$

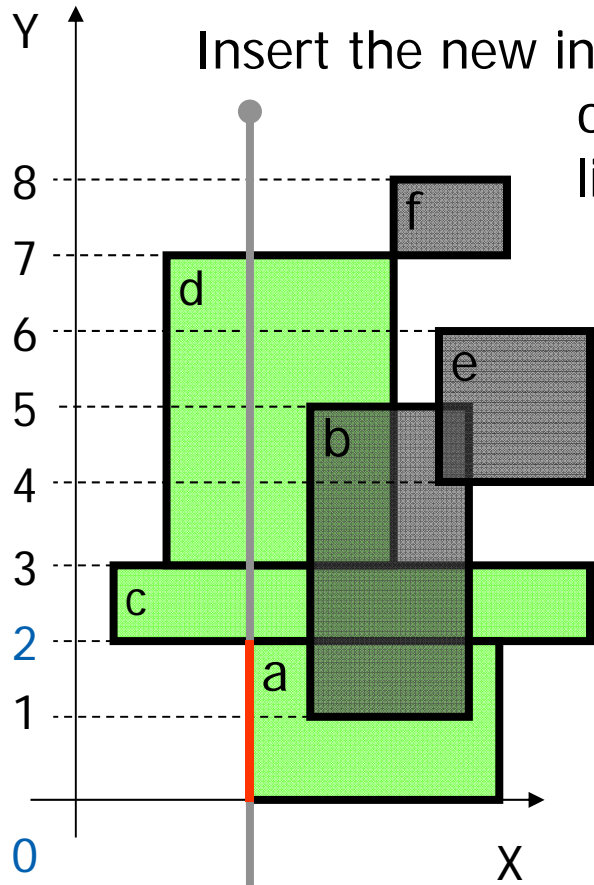

Insert the new interval to secondary lists

of the left son
link to parent

fork node => active
=> to lists

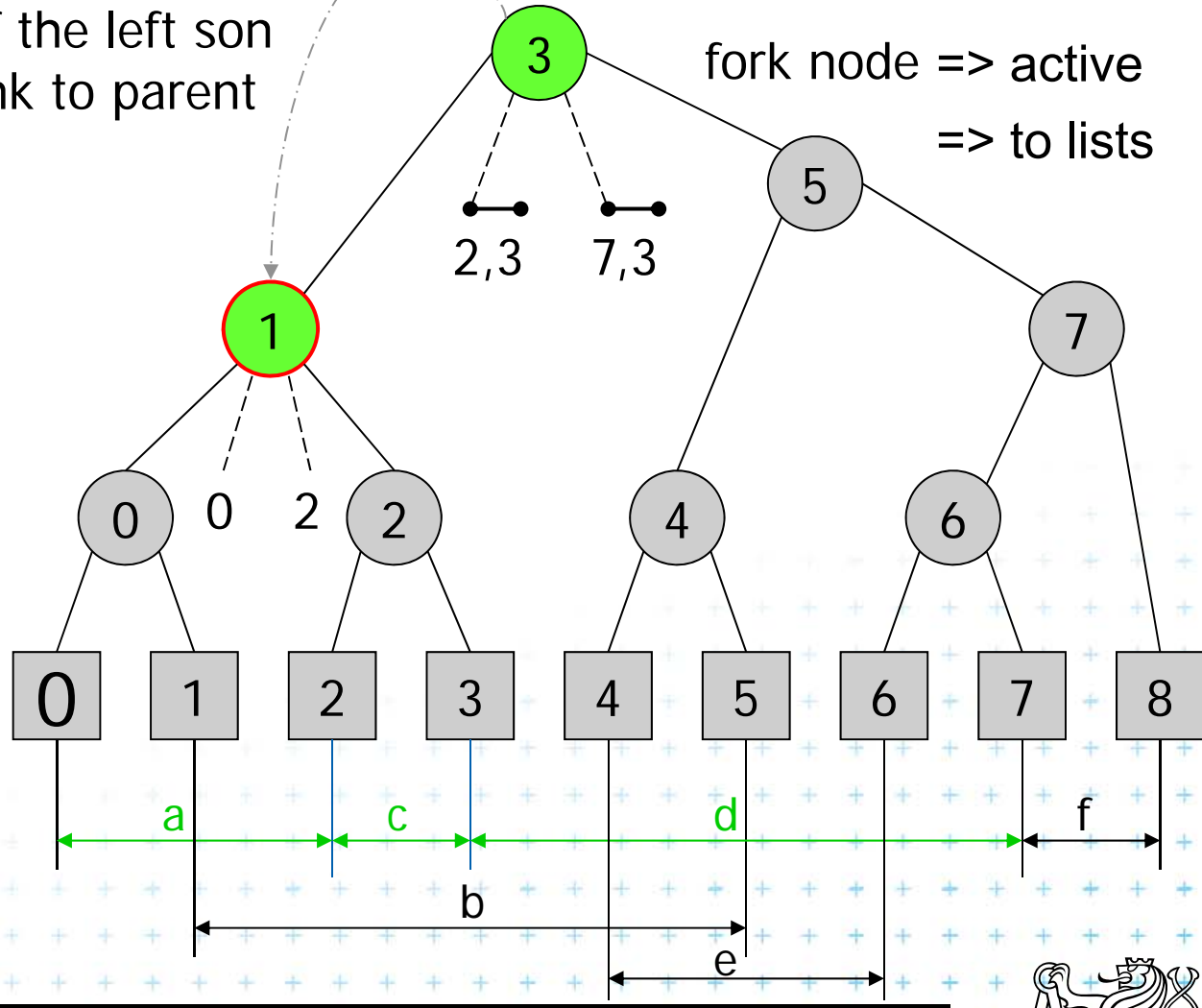

- Active rectangle
- Current node
- Active node



Insert [1,5] a) Query Interval 1/2

$$b < H(v) < e$$

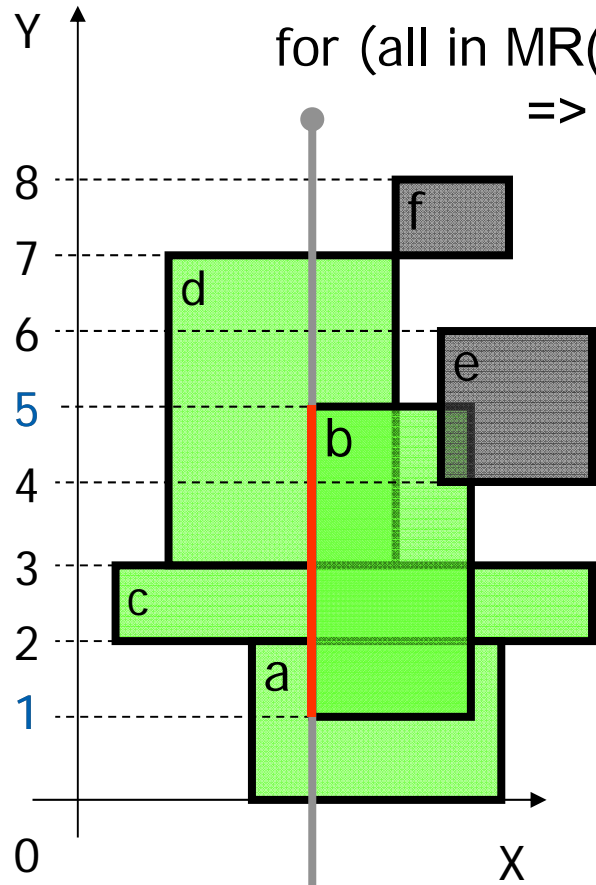

for (all in MR(v)) test $MR(v)[i] \geq 1$



=> report intersection c,d

go left -> 1

go right - nil

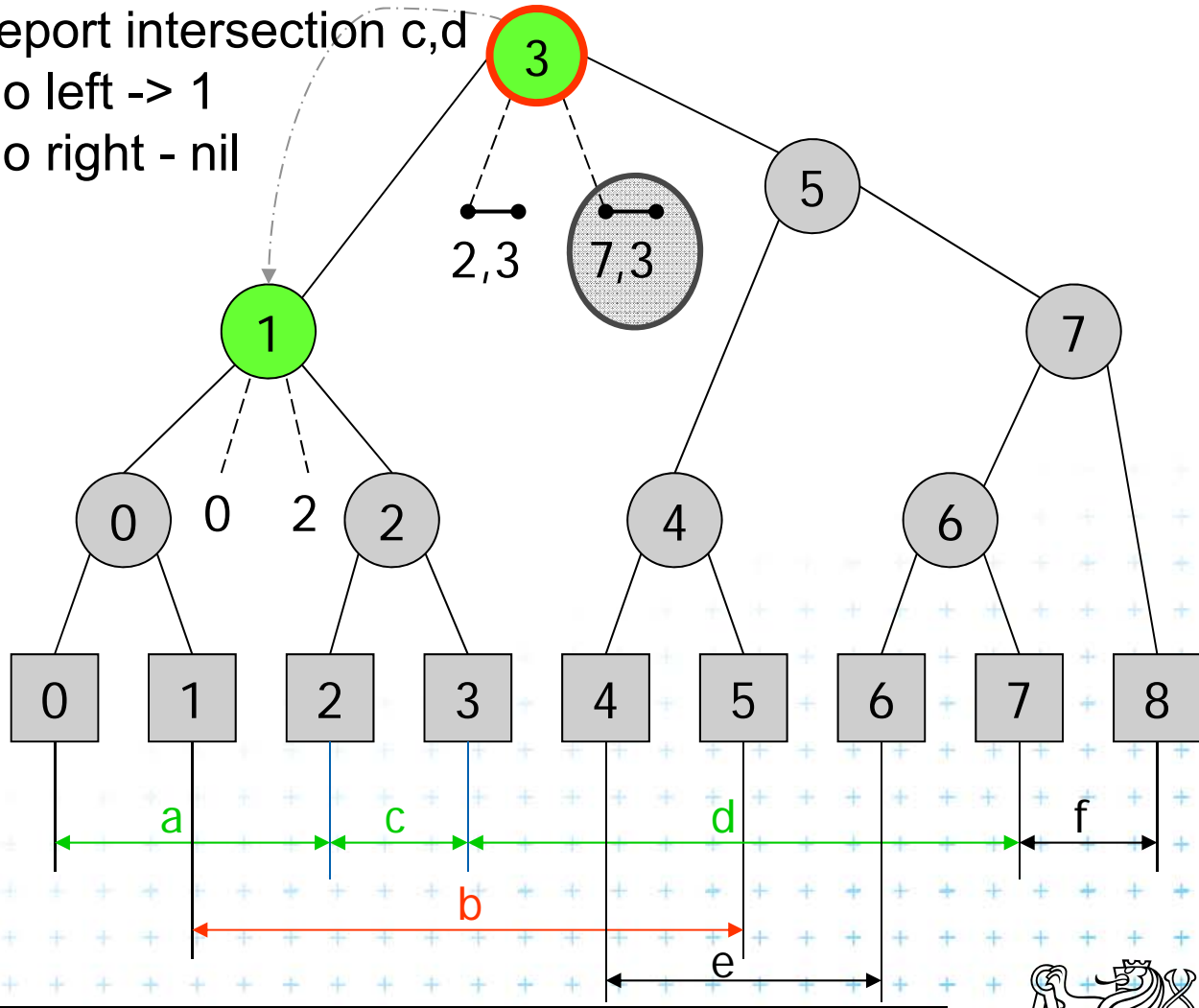
? 1 < 3 < 5 ?



-  Active rectangle
-  Current node
-  Active node



Insert [1,5] a) Query Interval 2/2

$$H(v) \leq b < e$$

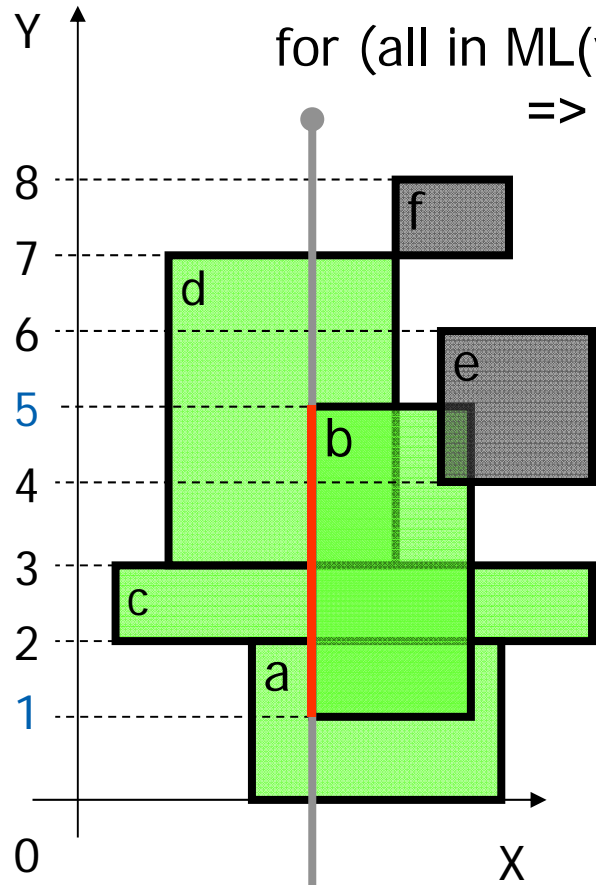

for (all in ML(v)) test $ML(v)[i] \geq 1$
 \Rightarrow report intersection a
 go left, nil, stop

? $1 \leq 1 < 5$?

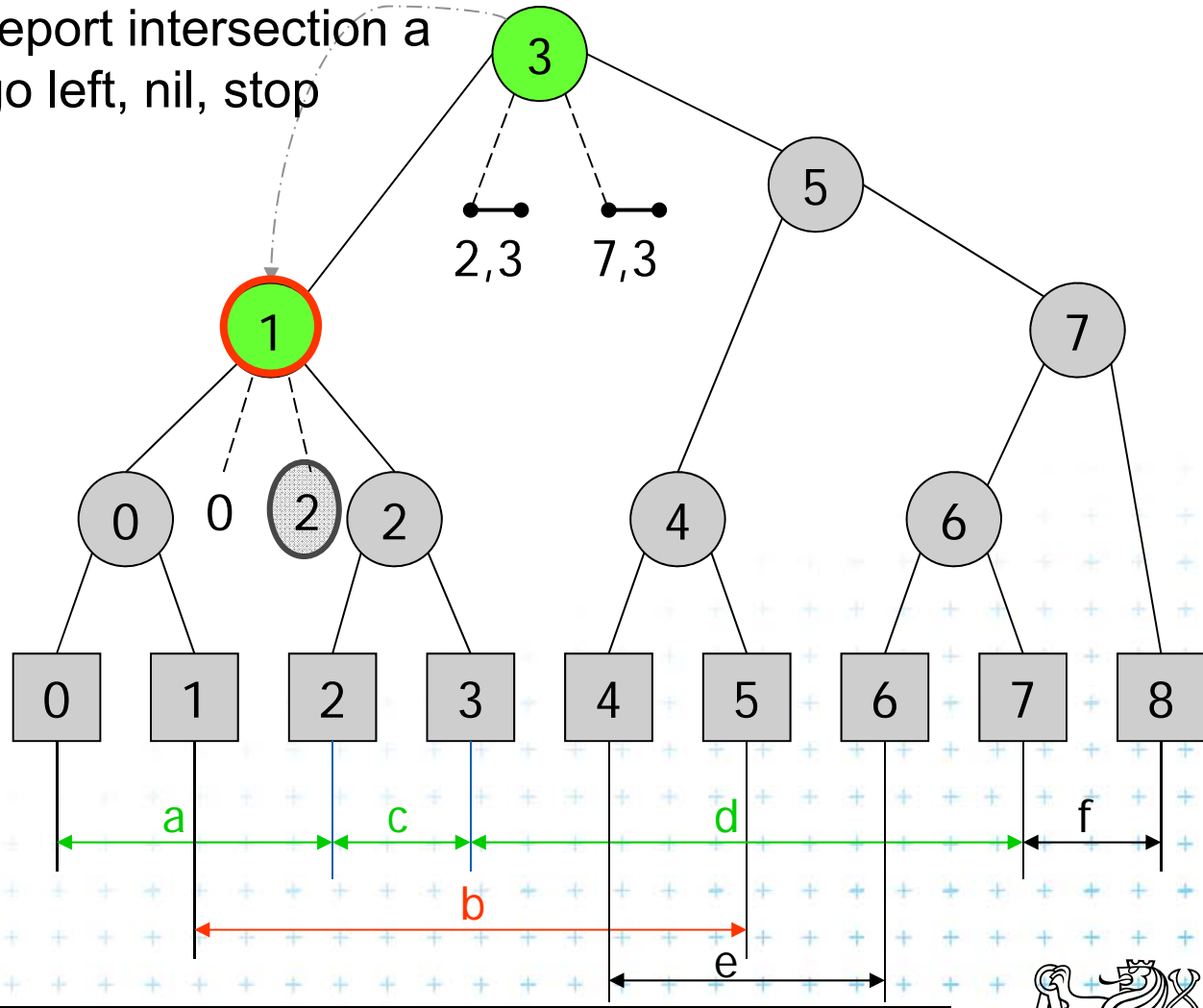

- Active rectangle
- Current node
- Active node



Insert [1,5] b) Insert Interval

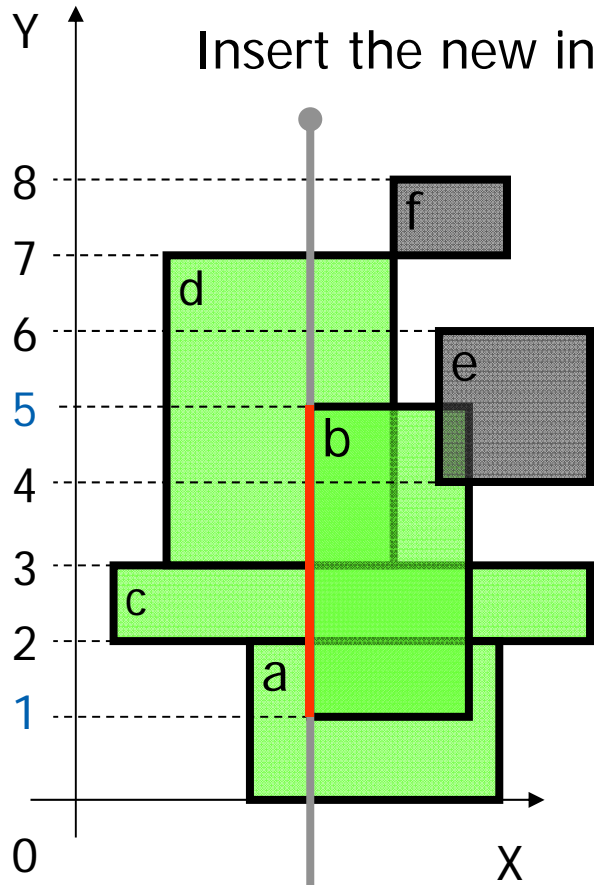

$$b \leq H(v) \leq e$$

$$? 1 \leq 3 \leq 5 ?$$

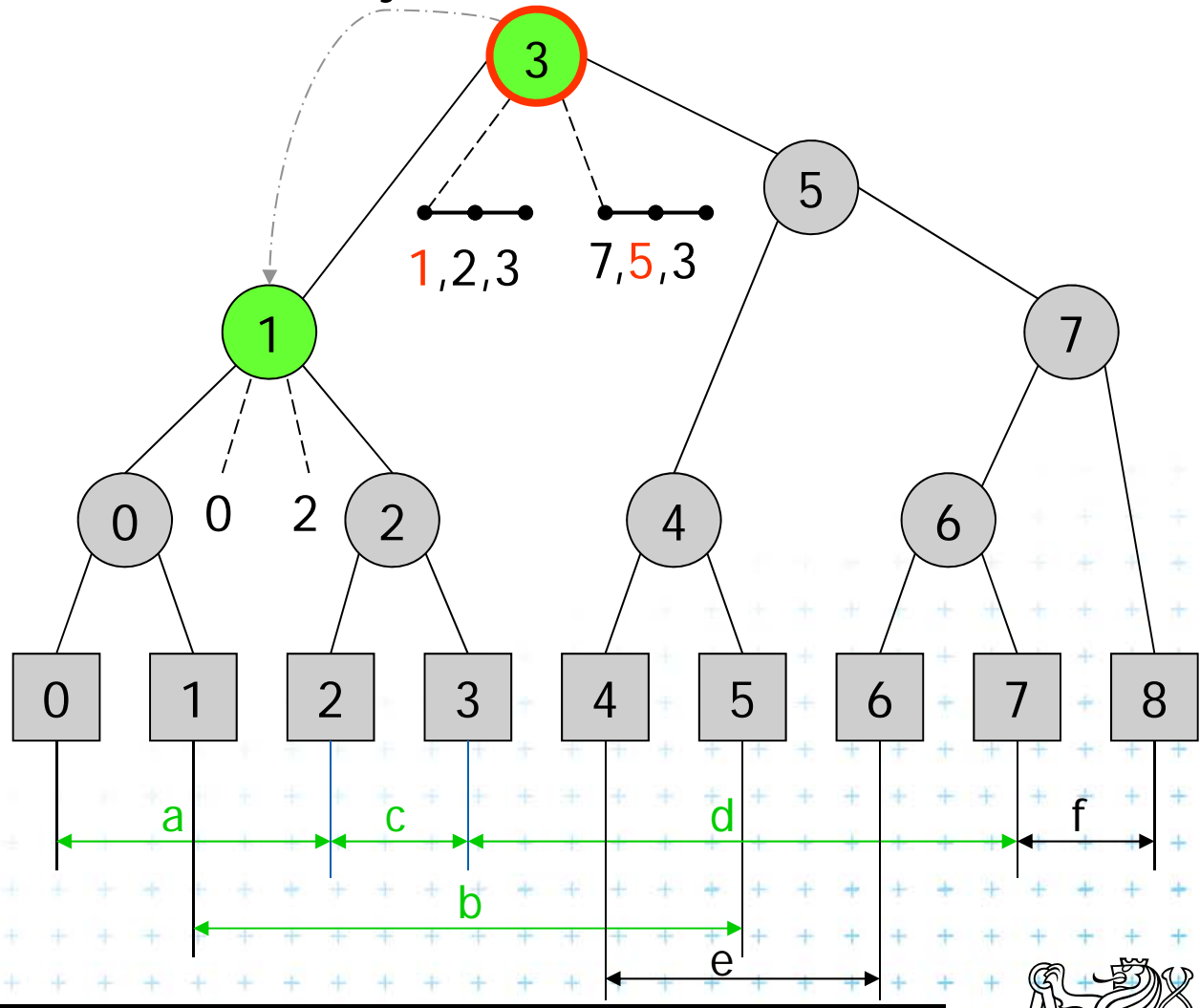

Insert the new interval to secondary lists



-  Active rectangle
-  Current node
-  Active node



Insert [7,8] a) Query Interval

$$H(v) \leq b < e$$

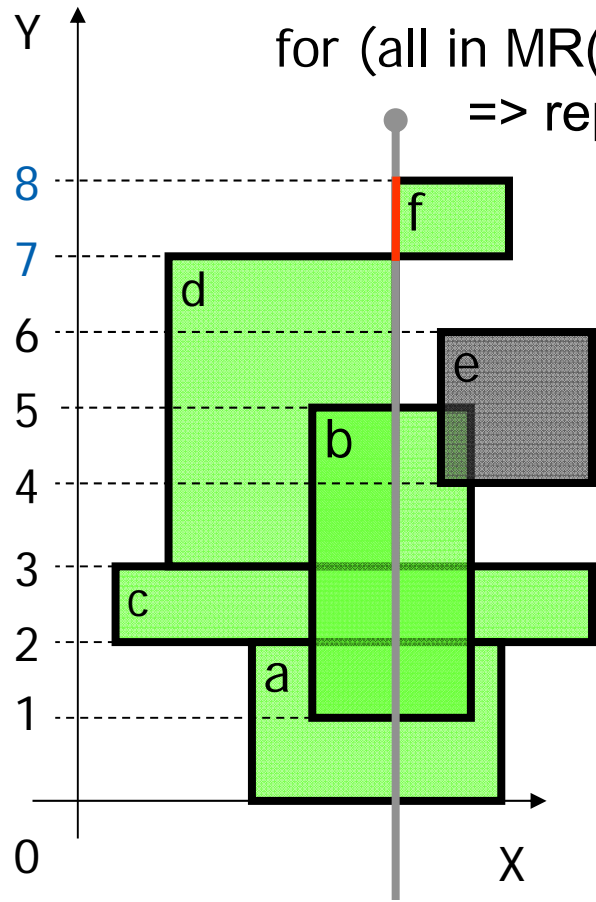

for (all in MR(v)) test MR(v).[i] ≥ 7
 \Rightarrow report intersection d
 go right, nil, stop

? $3 \leq 7 < 8$?

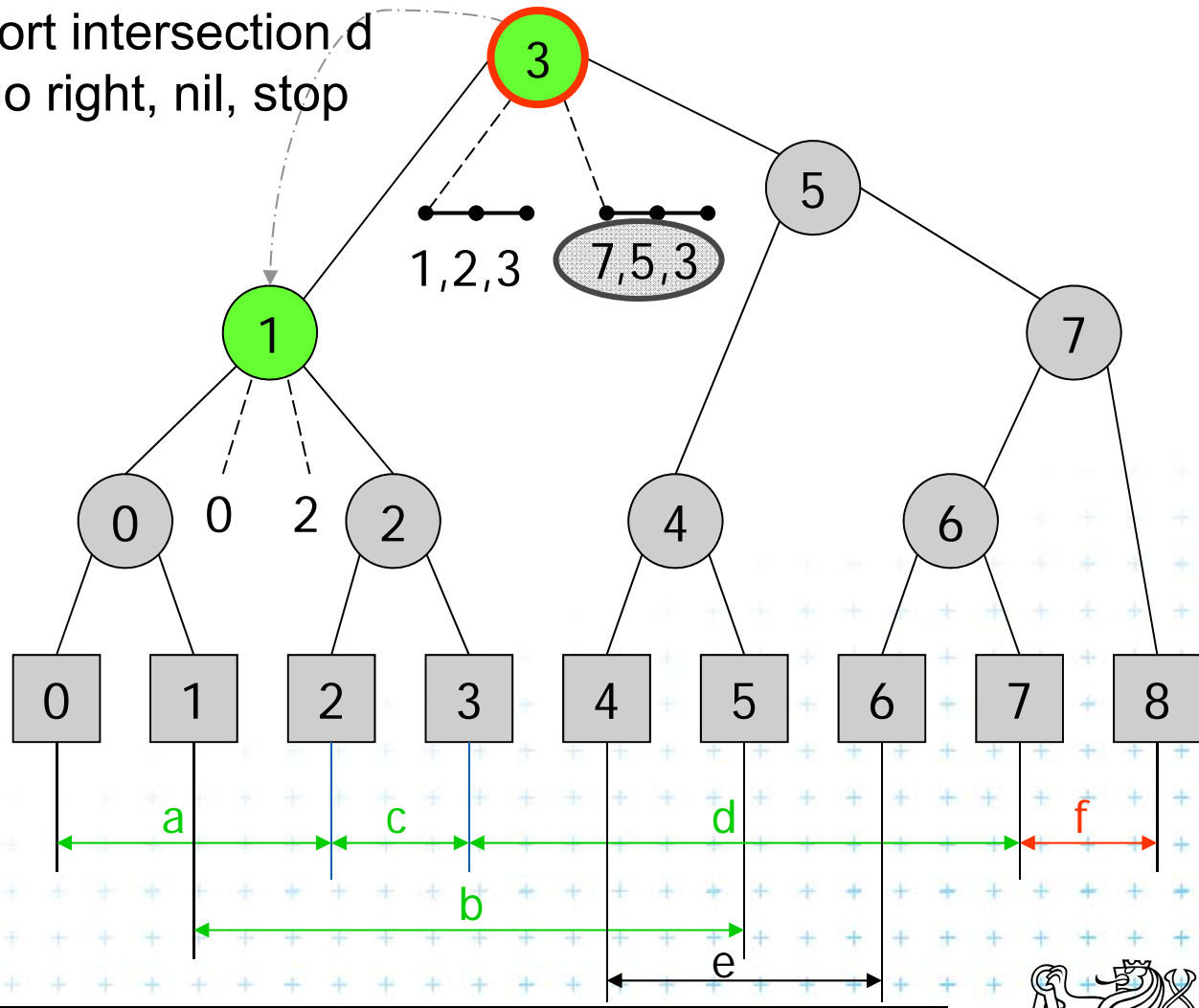

- Active rectangle
- Current node
- Active node



Insert [7,8] b) Insert Interval

$$b \leq H(v) \leq e$$

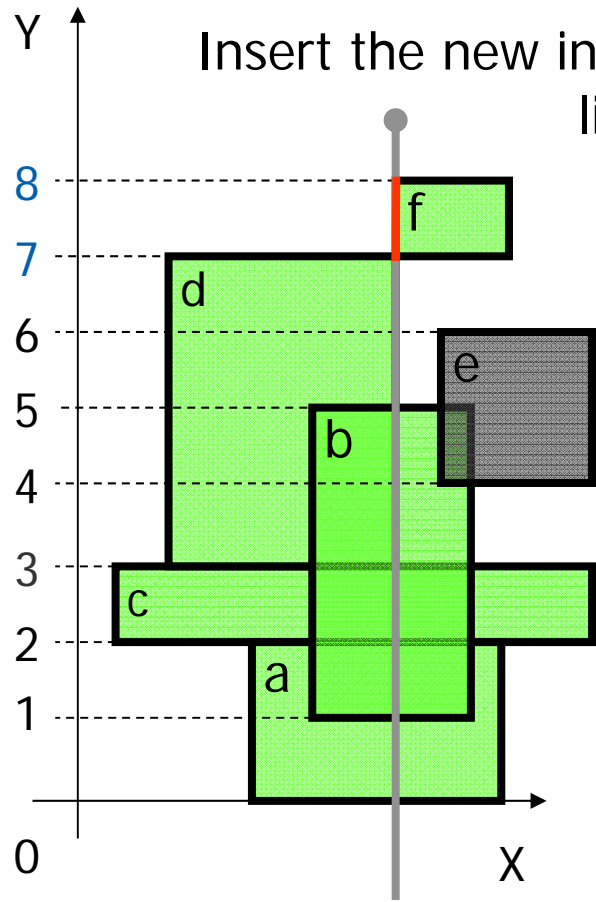

Insert the new interval to secondary lists

link to parent

right \leq ? $3 \leq 7 < 8$?
 right \leq ? $5 \leq 7 < 8$?
 $7 \leq 7 \leq 8$

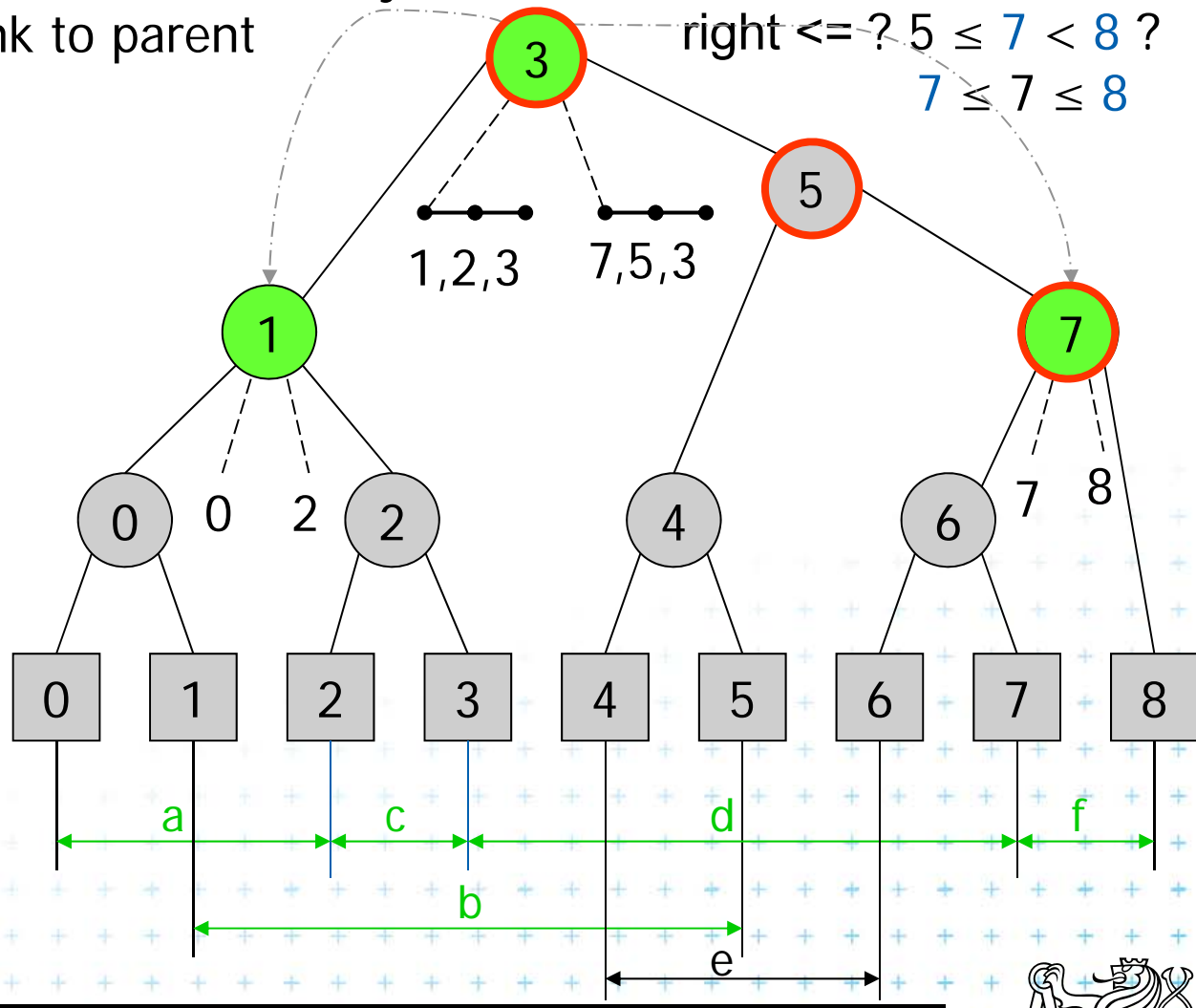

- Active rectangle
- Current node
- Active node



Delete [3,7] Delete Interval

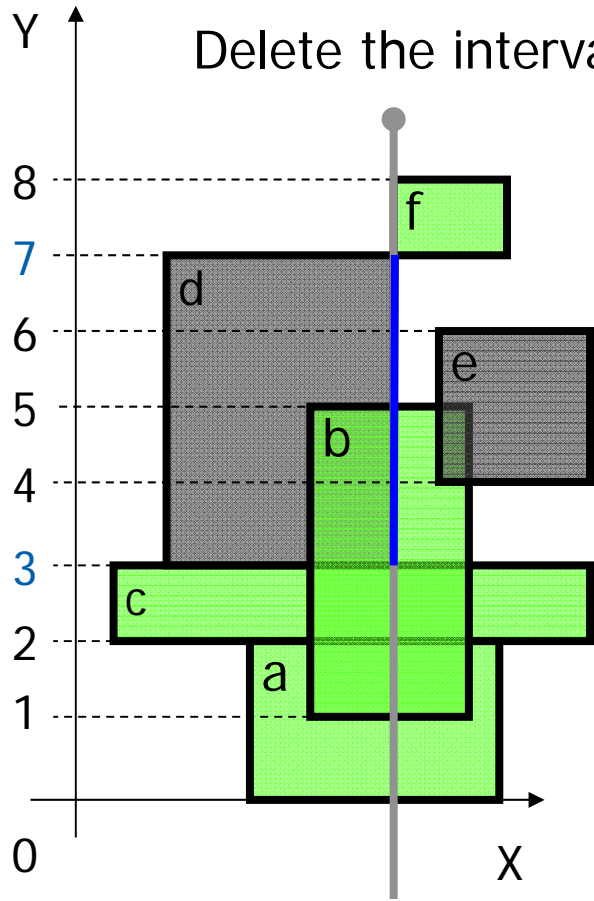

$$b \leq H(v) \leq e$$

$$? 3 \leq 7 \leq 8 ?$$

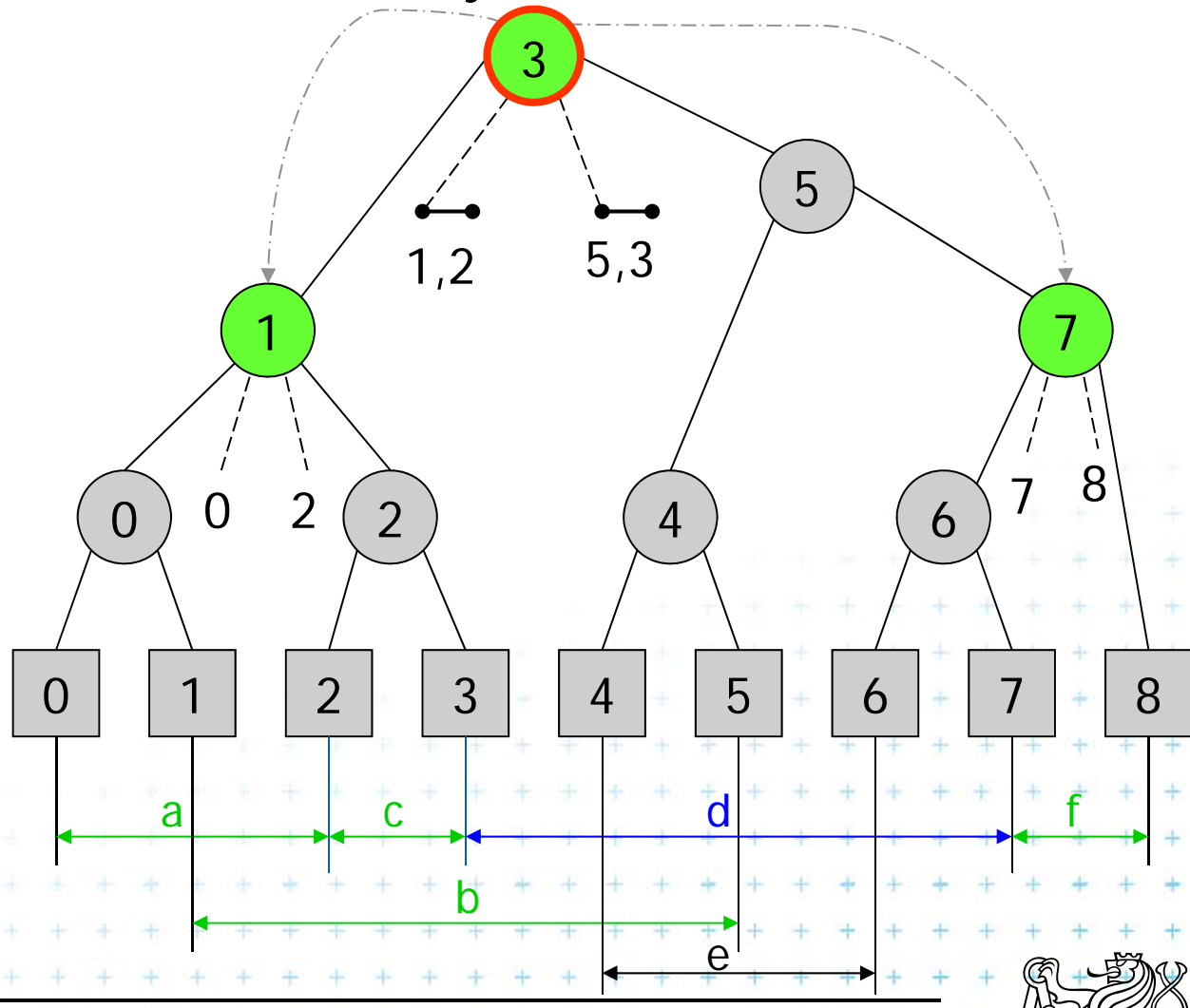

Delete the interval [3,7] from secondary lists



-  Active rectangle
-  Current node
-  Active node





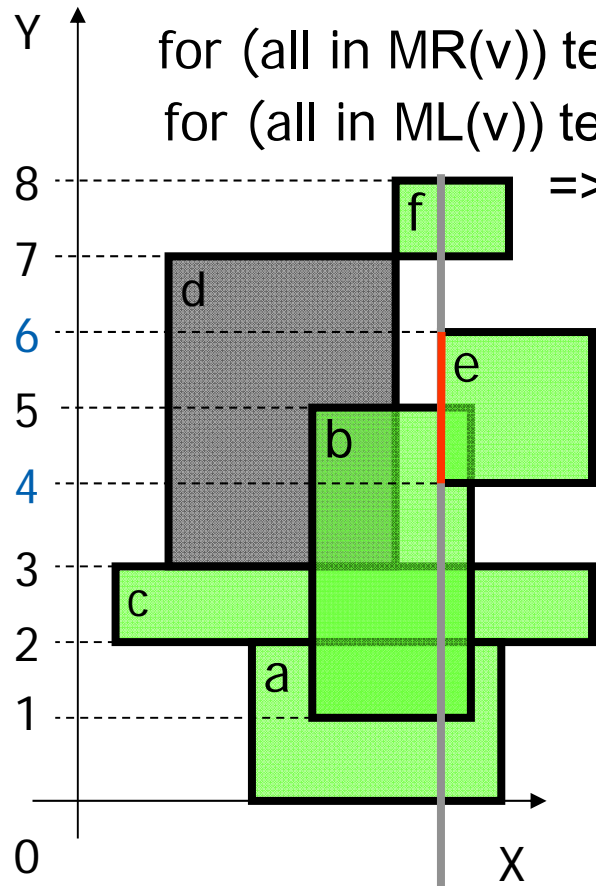

Insert [4,6] a) Query Interval

$$H(v) \leq b < e$$

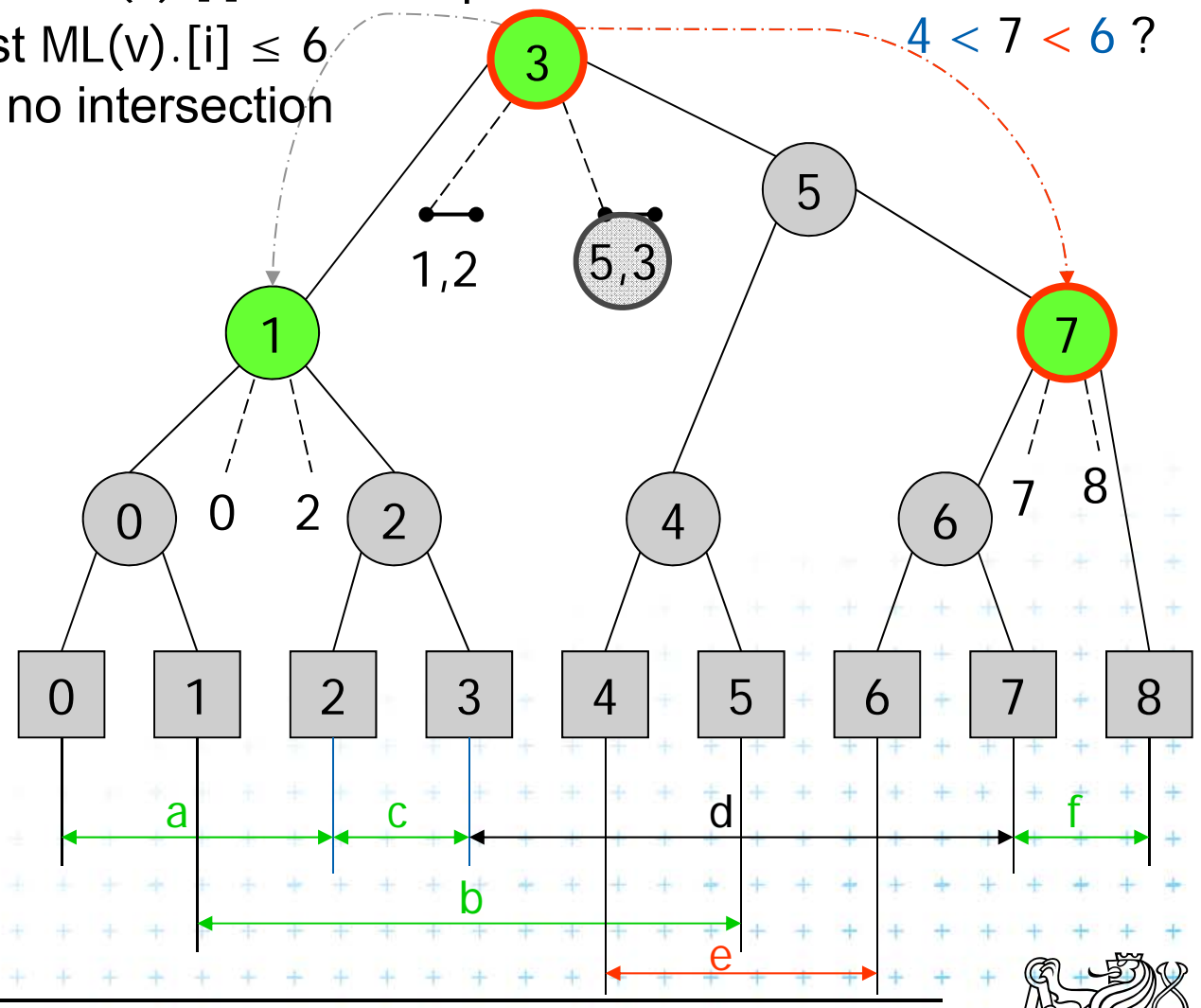

for (all in MR(v)) test $MR(v).[i] \geq 4 \Rightarrow$ report intersection b $3 \leq 4 < 6 ?$
 for (all in ML(v)) test $ML(v).[i] \leq 6 \Rightarrow$ no intersection $4 < 7 < 6 ?$



-  Active rectangle
-  Current node
-  Active node



Insert [4,6] b) Insert Interval

s

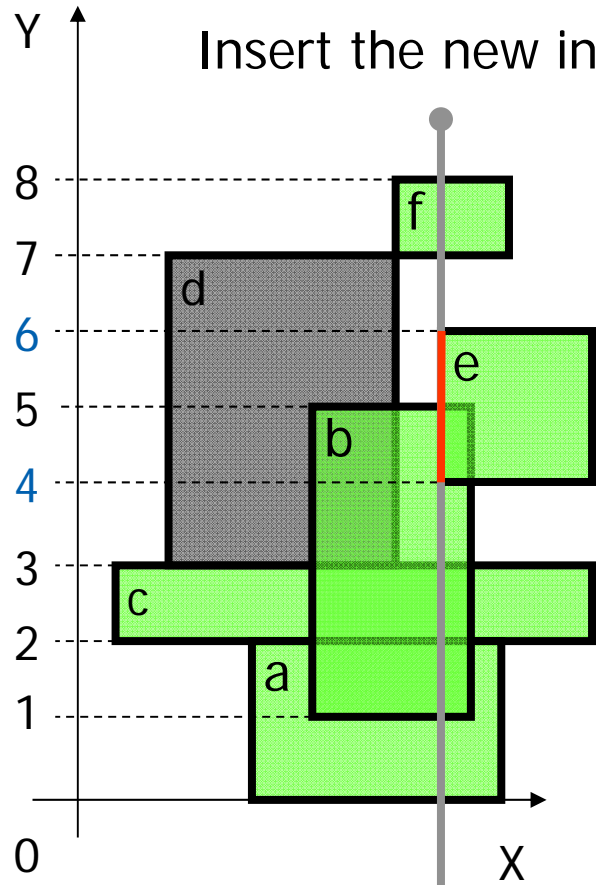



Insert the new interval to secondary lists

? $3 \leq 4 < 6$?

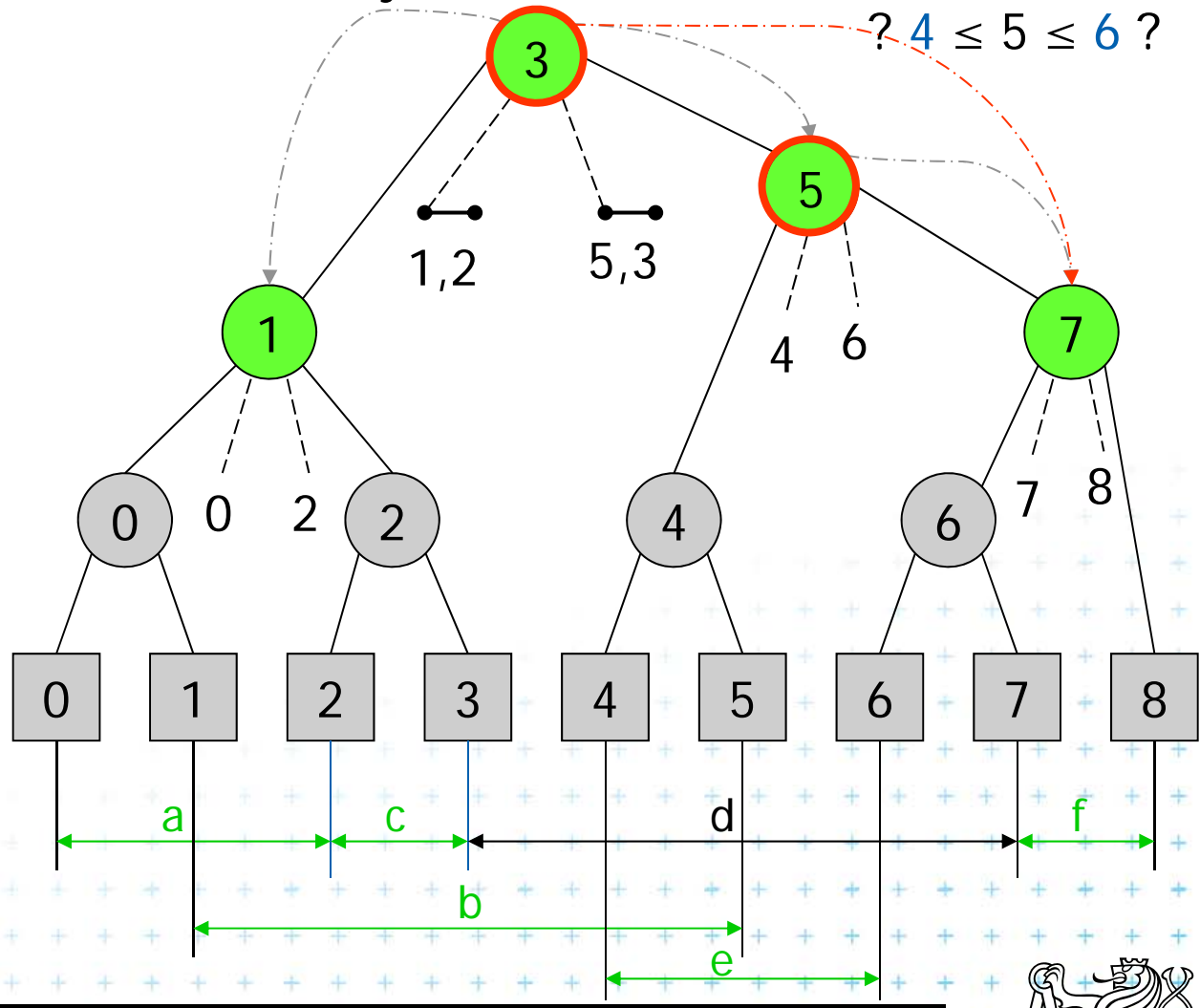
? $4 \leq 5 \leq 6$?



-  Active rectangle
-  Current node
-  Active node



Delete [1,5] Delete Interval

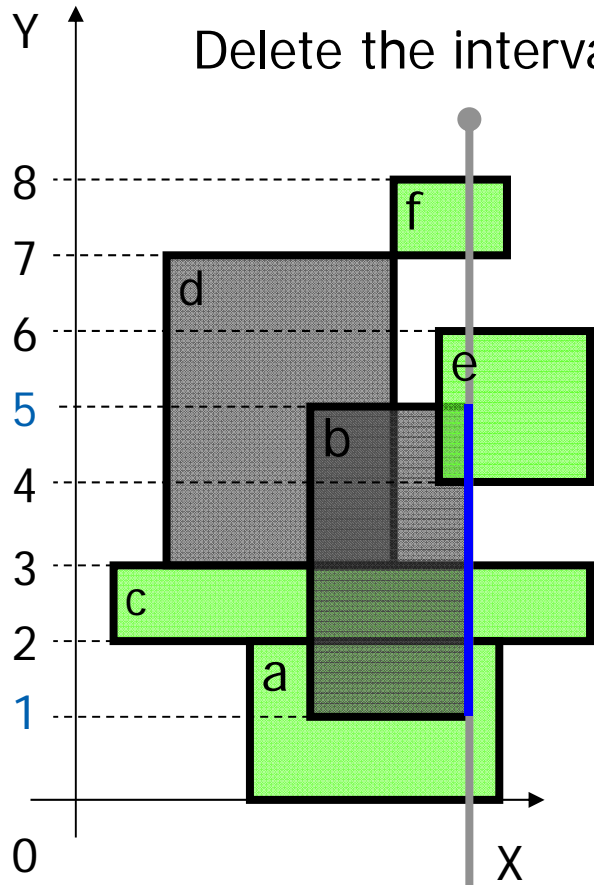

$$b \leq H(v) \leq e$$

$$? 1 \leq 3 \leq 5 ?$$

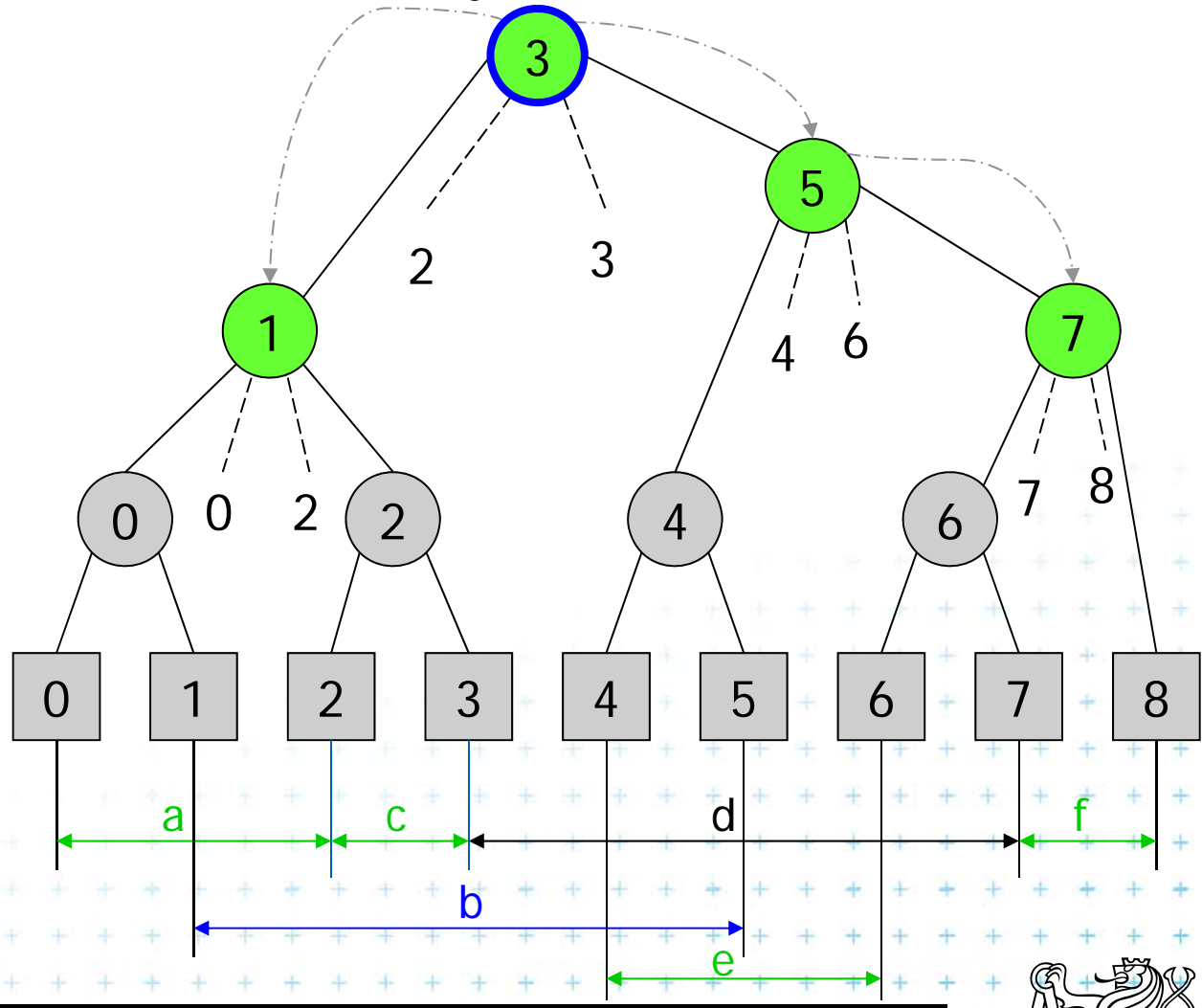

Delete the interval [1,5] from secondary lists



-  Active rectangle
-  Current node
-  Active node



Delete [0,2] Delete Interval 1/2

$$b < e \leq H(v)$$

$$? 0 < 2 \leq 3?$$

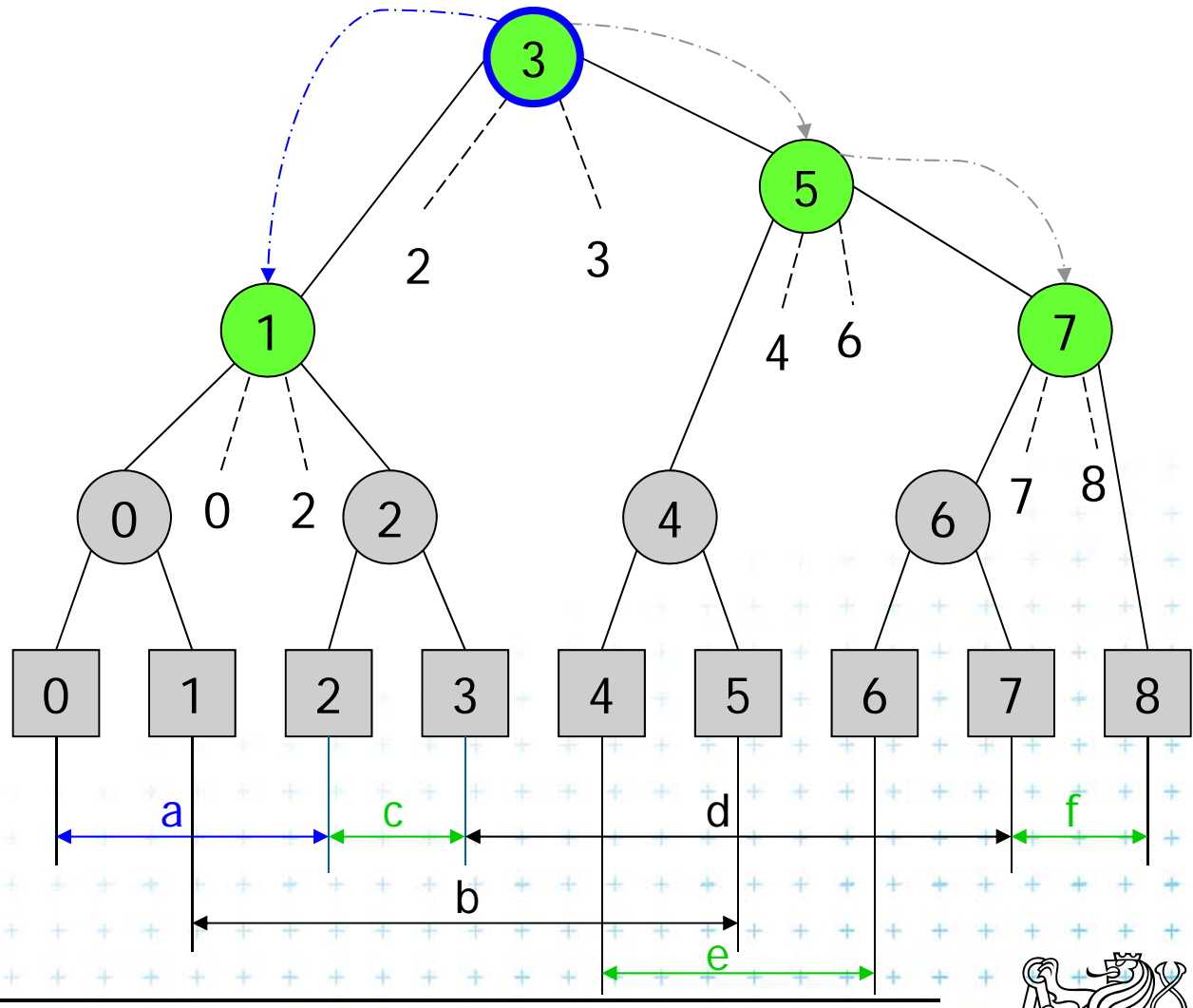
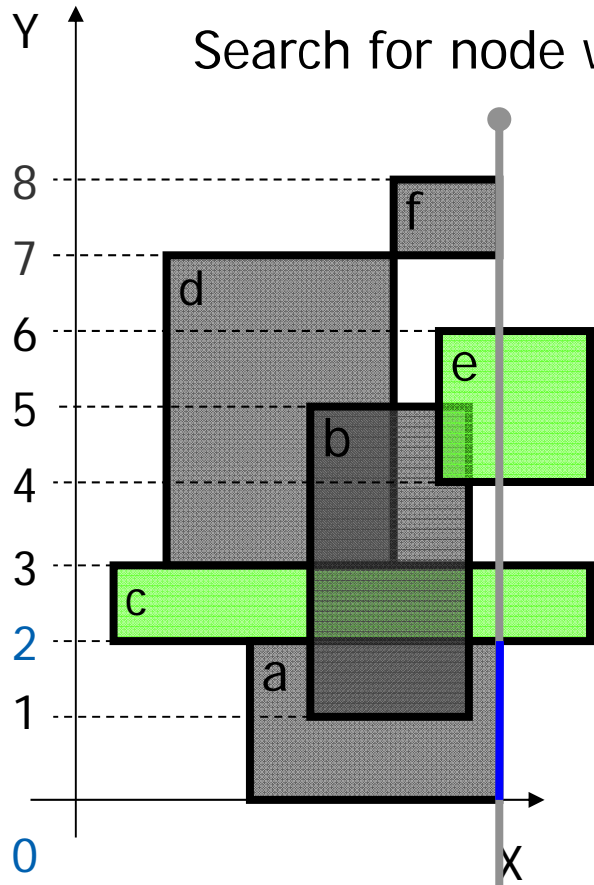

- Active rectangle
- Current node
- Active node



Delete [0,2] Delete Interval 2/2

$$b \leq H(v) \leq e$$

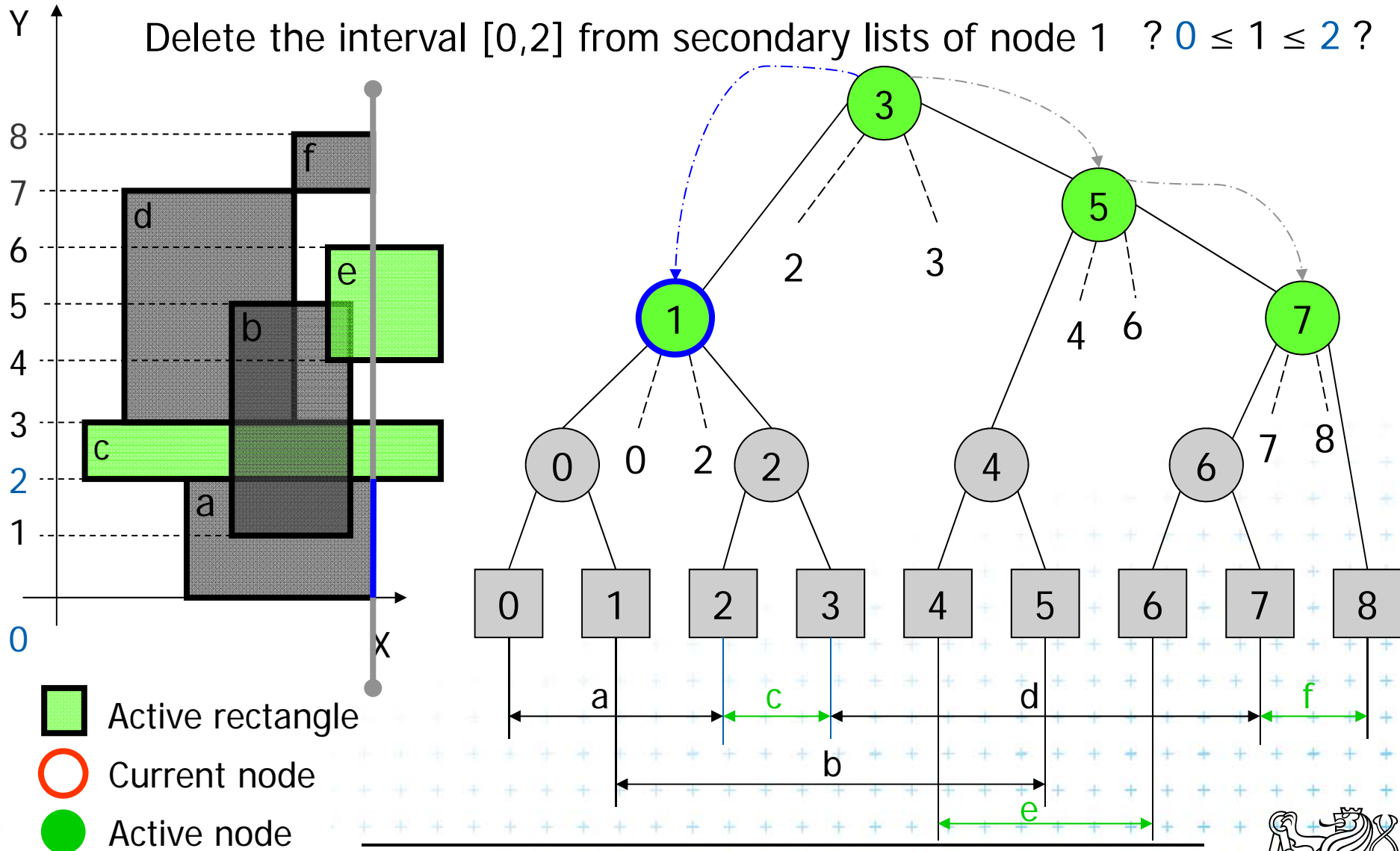

Delete [7,8] Delete Interval

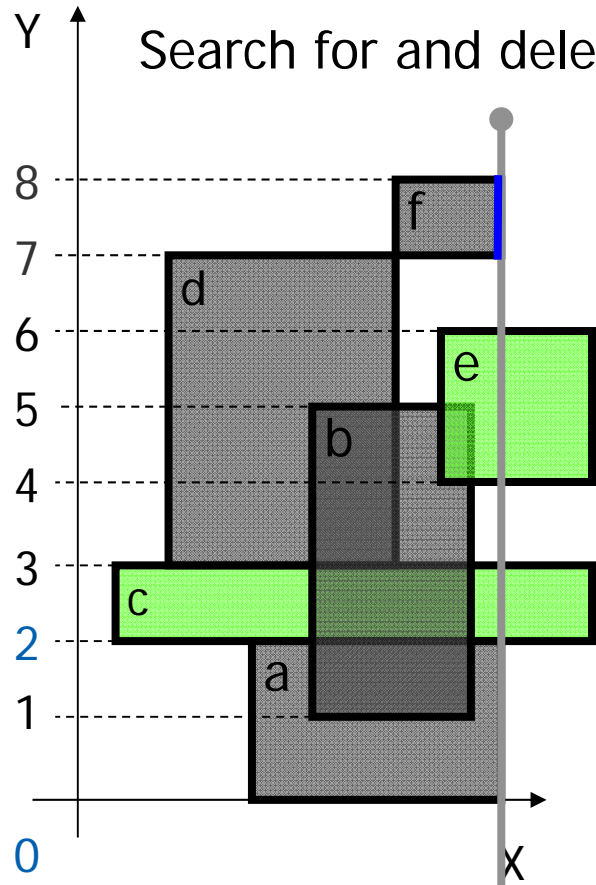

$$b \leq H(v) \leq e$$

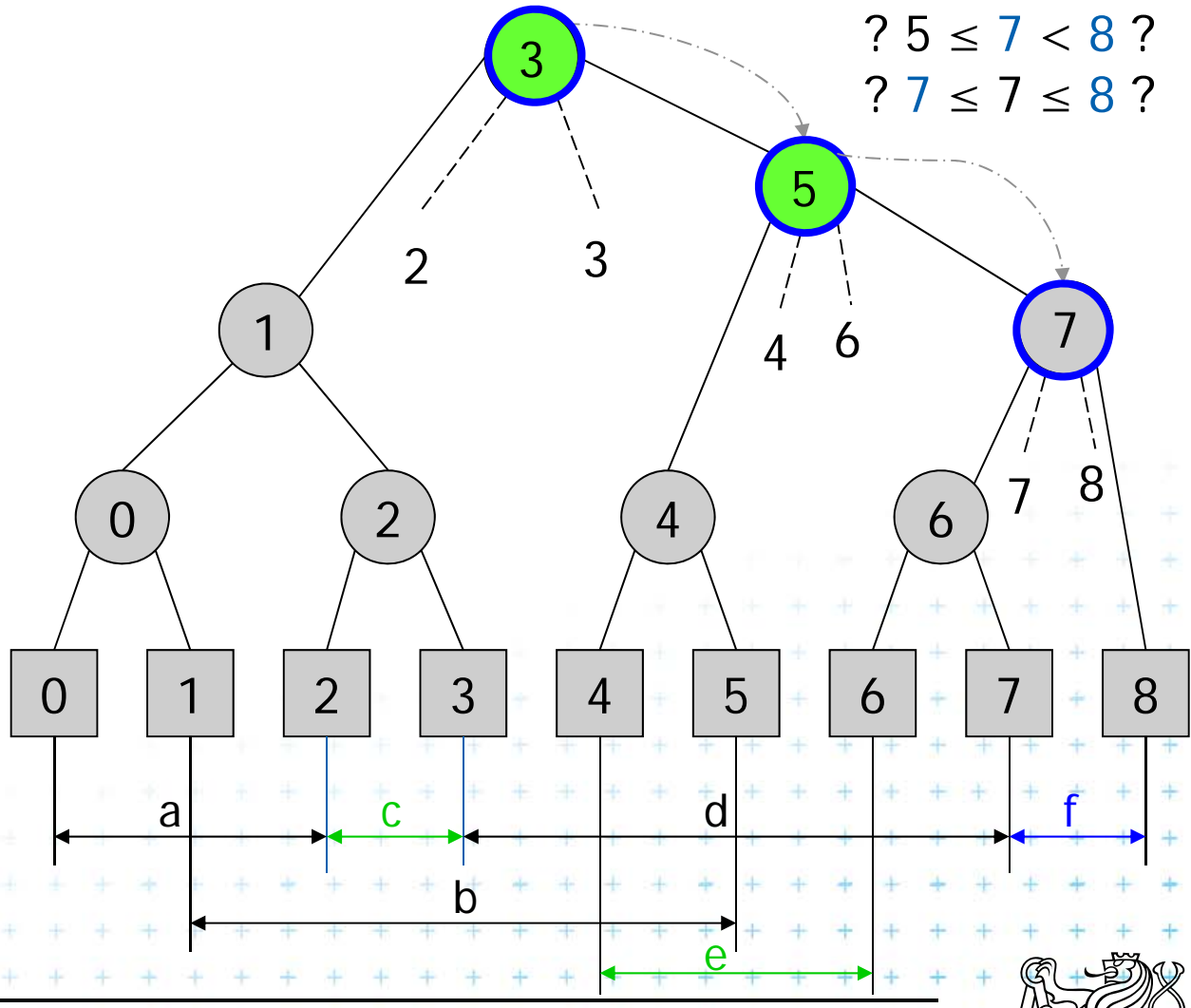

Search for and delete node with interval [7,8]

? $3 \leq 7 < 8$?
 ? $5 \leq 7 < 8$?
 ? $7 \leq 7 \leq 8$?



-  Active rectangle
-  Current node
-  Active node



Delete [2,3] Delete Interval

$$b \leq H(v) \leq e$$

$$? 2 \leq 3 \leq 3 ?$$

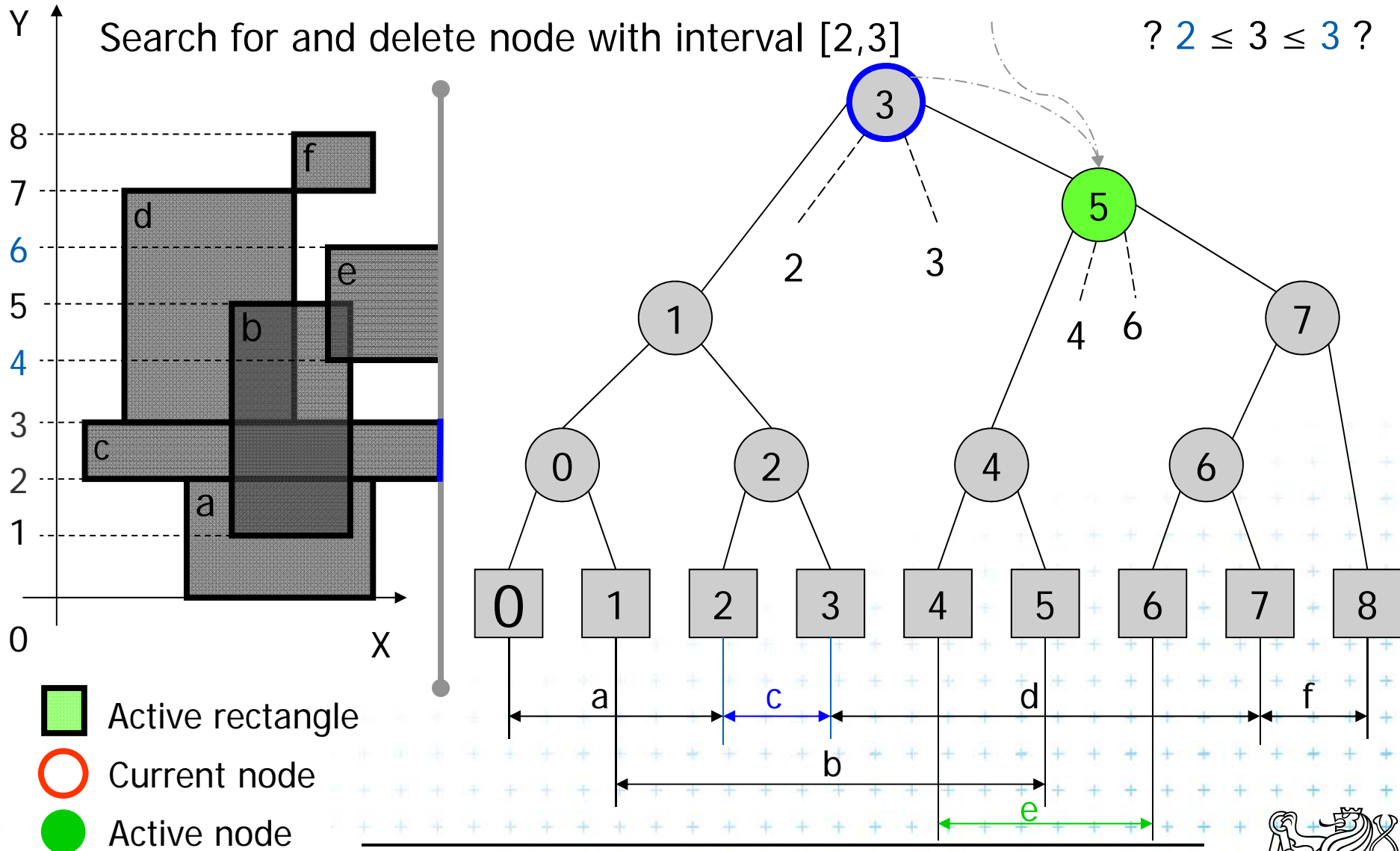

Delete [4,6] Delete Interval

$$b \leq H(v) \leq e$$

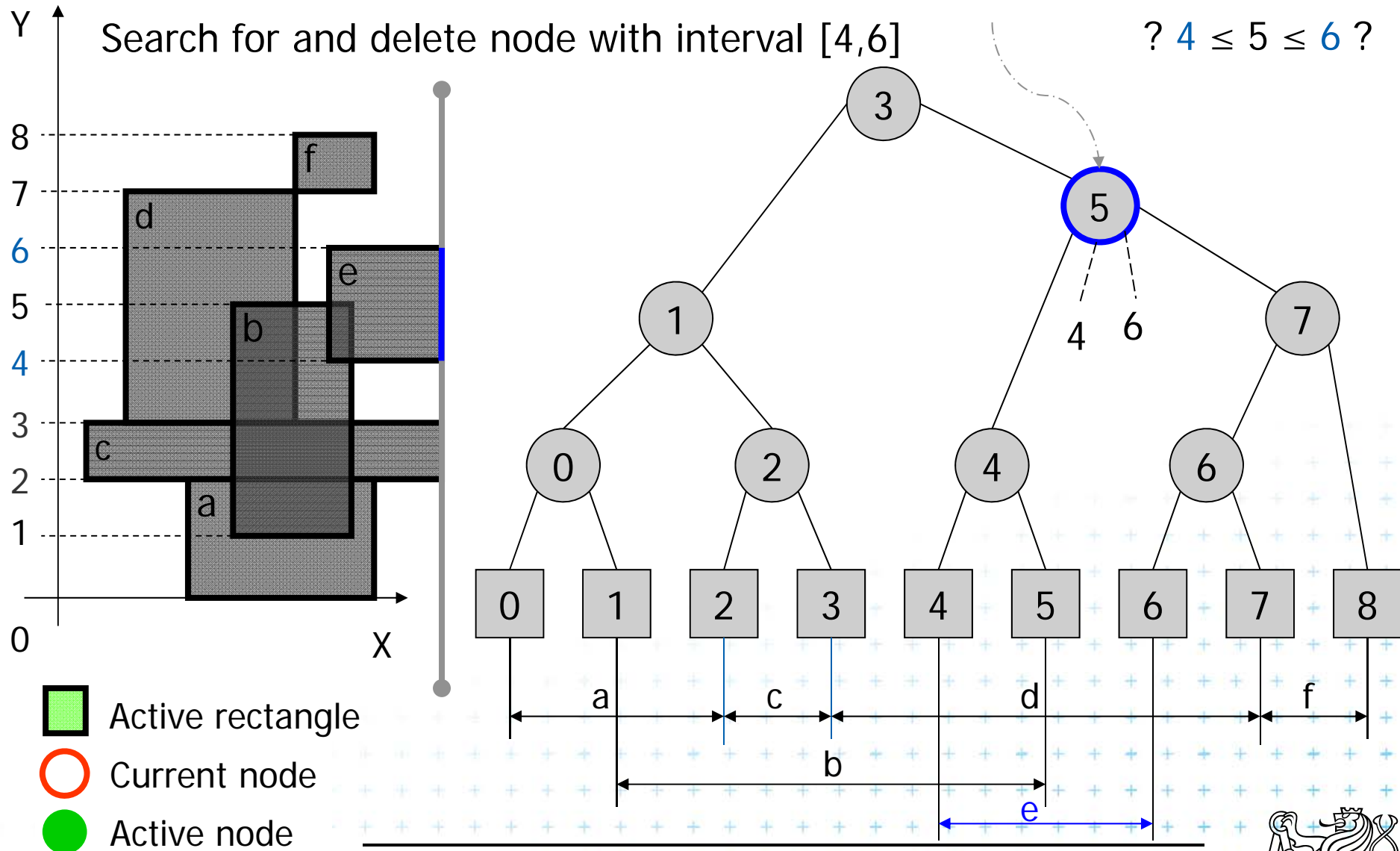

Complexities of rectangle intersections

- n rectangles, s intersected pairs found
- $O(n \log n)$ preprocessing time to separately sort
 - x-coordinates of the rectangles for the plane sweep
 - the y-coordinates for initializing the interval tree.
- The plane sweep itself takes $O(n \log n + s)$ time, so the overall time is $O(n \log n + s)$
- $O(n)$ space
- This time is optimal for a decision-tree algorithm (i.e., one that only makes comparisons between rectangle coordinates).



References

- [Berg] Mark de Berg, Otfried Cheong, Marc van Kreveld, Mark Overmars: Computational Geometry: Algorithms and Applications, Springer-Verlag, 3rd rev. ed. 2008. 386 pages, 370 fig. ISBN: 978-3-540-77973-5, Chapters 3 and 9, <http://www.cs.uu.nl/geobook/>
- [Mount] David Mount, - CMSC 754: Computational Geometry, Lecture Notes for Spring 2007, University of Maryland, Lectures 7,22, 13,14, and 30.
<http://www.cs.umd.edu/class/spring2007/cmsc754/lectures.shtml>
- [Rourke] Joseph O'Rourke: .: Computational Geometry in C, Cambridge University Press, 1993, ISBN 0-521- 44592-2
<http://maven.smith.edu/~orourke/books/compgeom.html>
- [Drtina] Tomáš Drtina: Intersection of rectangles. Semestral Assignment. Computational Geometry course, FEL CTU Prague, 2006
- [Kukral] Petr Kukrál: Intersection of rectangles. Semestral Assignment. Computational Geometry course, FEL CTU Prague, 2006
- [Vigneron] Segment trees and interval trees, presentation, INRA, France,
<http://w3.jouy.inra.fr/unites/miaj/public/vigneron/cs4235/slides.html>





**OPPA European Social Fund
Prague & EU: We invest in your future.**
