

Medical ultrasound imaging

J.Hozman, E.Dove, J.Kybic

2008–2019

Part I

Introduction to medical ultrasound

Introduction

Ultrasound acoustics

Waves

Wave equation

Reflection and refraction

Interface reflection

Attenuation

Medical ultrasound

Devices

Cardiologic US

Intravascular US

Artefacts

Generation/detection

Generation

Steering/Beamforming

Focusing

Processing and control

Medical ultrasound basics

- Acoustic waves, frequency 2 ~ 50 MHz
- Measure the time and intensity of the echo
- Harmless
- Stopped by air and dense tissues (bone)

Ultrasound Principle

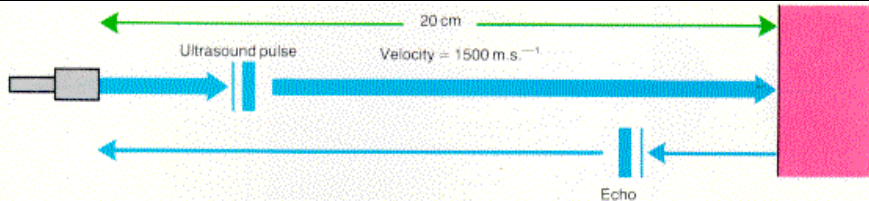

Round-trip distance = 40 cm

Time for echo to return = $267 \mu\text{s}$

Max. pulses per second = 3750

Introduction

Ultrasound acoustics

Waves

Wave equation

Reflection and refraction

Interface reflection

Attenuation

Medical ultrasound

Devices

Cardiologic US

Intravascular US

Artefacts

Generation/detection

Generation

Steering/Beamforming

Focusing

Processing and control

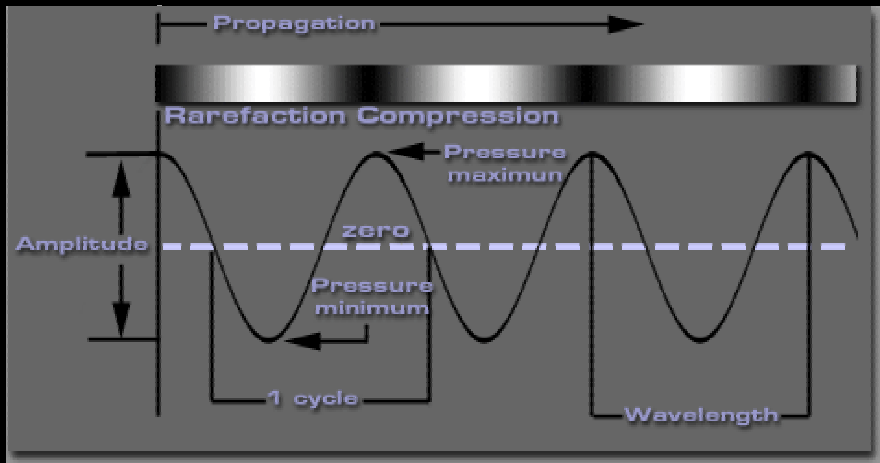

Sinusoidal pressure source

Fyzikální základy – rozsahy veličin

Měřená veličina	Symbol	Jednotka (rozměr)	Rozsah obvyklých hodnot měřené veličiny v klinické praxi
Rychlost	c	$\text{m}\cdot\text{s}^{-1}$	$1540 \text{ m}\cdot\text{s}^{-1}$ (měkká tkáň)
Vlnová délka	λ	mm	0,6 až 0,15 mm (měkká tkáň)
Kmitočet	f	hertz	2,5 až 10 MHz
Modul pružnosti	E	pascal	25 GPa (kost)
Akustická impedance	Z	$\text{kg}\cdot\text{m}^{-2}\cdot\text{s}^{-1}$	$1,63\cdot 10^6 \text{ kg}\cdot\text{m}^{-2}\cdot\text{s}^{-1}$
Hustota	ρ	$\text{kg}\cdot\text{m}^{-3}$	$1000 \text{ kg}\cdot\text{m}^{-3}$ (voda)
Intenzita	I	$\text{W}\cdot\text{cm}^{-2}$	typicky 1 až 10 $\text{mW}\cdot\text{cm}^{-2}$
Tlak	p	pascal nebo bar	0,6 baru nebo 0,06 MPa



Elementary volume

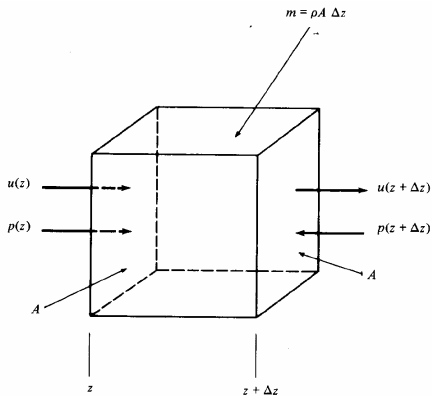

Speed u , pressure p , density ρ , area A , mass m .

Newton's law

Motion along z :

$$F = ma = m \frac{du}{dt} = m \left(\frac{\partial u}{\partial t} + \frac{\partial u}{\partial z} \frac{\partial z}{\partial t} \right) \approx m \frac{\partial u}{\partial t}$$

force $F = pA$:

$$(p(z) - p(z + \Delta z)) A = m \frac{\partial u}{\partial t}$$

for $\Delta z \ll z$:

$$-\frac{\partial p}{\partial z} \Delta z A = m \frac{\partial u}{\partial t}$$

as $m = \rho A \Delta z$

$$-\frac{\partial p}{\partial z} = \rho \frac{\partial u}{\partial t}$$

Conservation of mass law

Difference of entering and exiting mass, density change:

$$A(u(z + \Delta z)\rho(z + \Delta z) - u(z)\rho(z)) = -A\Delta z \frac{\partial \rho}{\partial t}$$

for $\Delta z \ll z$:

$$\frac{\partial \rho u}{\partial z} = -\frac{\partial \rho}{\partial t}$$

density $\rho = \rho_0 + \rho_1$, $\rho_0 = \text{const}$, $\rho_1 \ll \rho_0$:

$$\rho_0 \frac{\partial u}{\partial z} + \frac{\partial \rho_1}{\partial t} = 0$$

Compressibility (stlačitelnost) $\frac{\rho_1}{\rho_0} = Kp$, $K = 1/E$:

$$\frac{\partial u}{\partial z} + K \frac{\partial p}{\partial t} = 0$$

1D wave equation

$$\rho \frac{\partial u}{\partial t} + \frac{\partial p}{\partial z} = 0 \quad \text{derive by } z$$

$$\frac{\partial u}{\partial z} + K \frac{\partial p}{\partial t} = 0 \quad \text{derive by } t$$

$$\rho \frac{\partial^2 u}{\partial t \partial z} + \frac{\partial^2 p}{\partial z^2} = 0$$

$$\frac{\partial^2 u}{\partial z \partial t} + K \frac{\partial^2 p}{\partial t^2} = 0$$

subtract

$$\frac{\partial^2 p}{\partial z^2} - K \rho \frac{\partial^2 p}{\partial t^2} = 0$$

similarly

$$\frac{\partial^2 u}{\partial z^2} - K \rho \frac{\partial^2 u}{\partial t^2} = 0$$

Wave equation solution

Harmonic wave:

$$p = p_+ \cos(\omega t - kz)$$

where k is the wave number (vlnové číslo) [rad/m]. It is a solution if:

$$k^2 = \rho_0 K \omega^2$$

Wave speed (phase velocity):

$$c = \omega/k = \lambda f$$

Speed of Sound in Tissue



- The speed of sound in a human tissue depends on the average density ρ ($\text{kg}\cdot\text{m}^3$) and the compressibility K ($\text{m}^2\cdot\text{N}^{-1}$) of the tissue.

$$c = \frac{1}{\sqrt{\rho_0 K}}$$

Other wave equation solution

$$p = p_- \cos(\omega t + kz)$$

Any forward or backward wave (by linearity and harmonic decomposition).

Forward and backward wave combination:

$$p = p' \left(\cos(\omega t - kz) + \cos(\omega t + kz) \right)$$

Standing wave:

$$p = 2p' \cos(\omega t) \cos(kz)$$



Tissue Characteristics

- Engineers and scientists working in ultrasound have found that a convenient way of expressing relevant tissue properties is to use characteristic (or acoustic) impedance Z ($\text{kg}\cdot\text{m}^{-2}\cdot\text{s}^{-1}$)

$$Z = \rho_0 c$$

Acoustic impedance

$$Z_a = \frac{p \text{ (pressure)}}{I \text{ (flow)}} \text{ [Pa} \cdot \text{s/m}^3\text{]}$$

“acoustic Ohm”.

For an infinite tube:

$$Z_a = \frac{\rho_0 c}{S}$$

$Z = \rho_0 c$ is a specific acoustic impedance.

Unit $[\text{kg/s} \cdot \text{m}^2] = 1 \text{ Rayl}$.

Fyzikální základy - veličiny

Materiál	Rychlost zvuku c $\text{m}\cdot\text{s}^{-1}$	Hustota ρ $\text{kg}\cdot\text{m}^{-3}$	Akustická impedance Z $\text{kg}\cdot\text{m}^{-2}\cdot\text{s}^{-1} (\times 10^6)$	Koeficient absorpce α $\text{dB}\cdot\text{cm}^{-1}\cdot\text{MHz}^{-1}$
Vzduch	330	1,3	0,00043	
Tuk	1470	970	1,42	0,6
Ricínový olej	1500	933	1,40	
Voda	1492	1000	1,48	
Měkká tkáň	1500	<1000	~1,45	1,0
Mozek	1530	1020	1,56	0,85
Krev	1570	1020	1,60	0,18
Ledviny	1561	1030	1,61	
Játra	1549	1060	1,64	0,9
Sval	1568	1040	1,63	
Sval (podélná vlákna)			1,2	1,65
Sval (příčná vlákna)			3,3	1,65
Oční čočky	1620	1130	1,83	2,0
Kost	4080	1700	6,12	6,1
Plast			3,2	2,0

Specular Reflection



- The first, specular echoes, originate from relatively large, strongly reflective, regularly shaped objects with smooth surfaces. These reflections are angle dependent, and are described by reflectivity equation . This type of reflection is called specular reflection.

Primární parametrické pole a modulace ultrazvukového signálu

- útlum UZV energie,
- odraz a lom UZV vln,

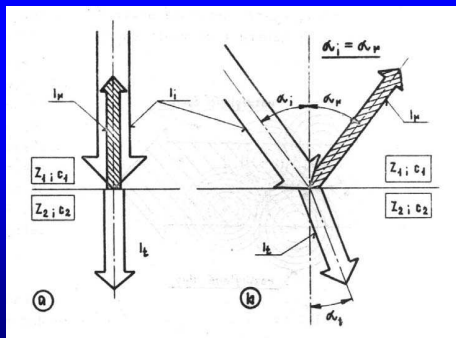

Reflectivity



$$R = \frac{p_r}{p_i} = \frac{\frac{Z_2}{\cos\theta_t} - \frac{Z_1}{\cos\theta_i}}{\frac{Z_2}{\cos\theta_t} + \frac{Z_1}{\cos\theta_i}}$$

At normal incidence, $\theta_i = \theta_t = 0$ and

$$R = \frac{Z_2 - Z_1}{Z_2 + Z_1}$$

Reflectivity for Various Tissues



<i>Materials at Interface</i>	<i>Reflectivity</i>
Brain-skull bone	0.66
Fat-muscle	0.10
Fat-kidney	0.08
Muscle-blood	0.03
Soft tissue-water	0.05
Soft tissue-air	0.9995

Scattered Reflection



- The second type of echoes are scattered that originate from small, weakly reflective, irregularly shaped objects, and are less angle-dependent and less intense. The mathematical treatment of non-specular reflection (sometimes called “speckle”) involves the Rayleigh probability density function. This type of reflection, however, sometimes dominates medical images, as you will see in the laboratory demonstrations.



SPECULAR ECHOES



SCATTERED ECHOES

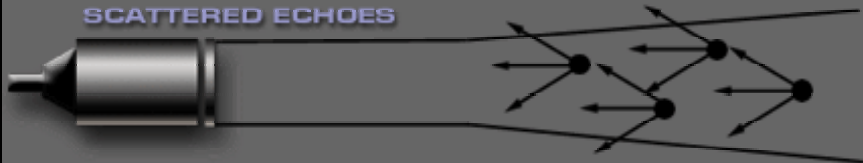

Echoes from Two Interfaces

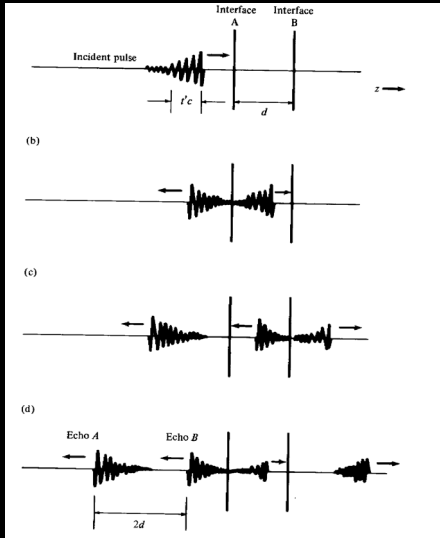

Echoes from Internal Organ

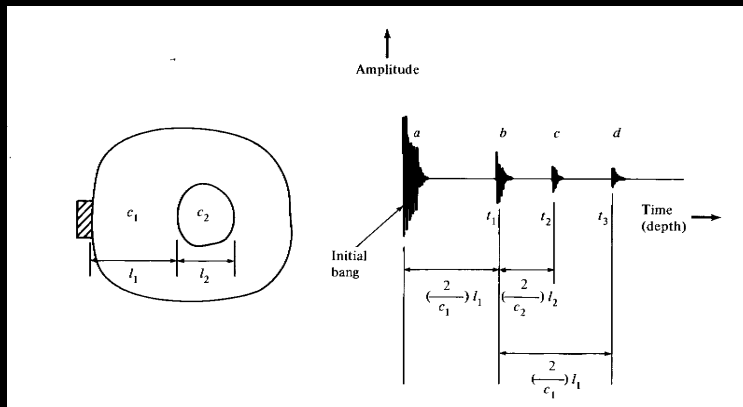

Attenuation



- Most engineers and scientists working in the ultrasound characterize attenuation as the “half-value layer,” or the “half-power distance.” These terms refer to the distance that ultrasound will travel in a particular tissue before its amplitude or energy is attenuated to half its original value.

Attenuation



- Divergence of the wavefront
- Elastic reflection of wave energy
- Elastic scattering of wave energy
- Absorption of wave energy

Ultrasound Attenuation



<i>Material</i>	<i>Half-power distance (cm)</i>
Water	380
Blood	15
Soft tissue	5 to 1
except muscle	1 to 0.6
Bone	0.7 to 0.2
Air	0.08
Lung	0.05

Attenuation



- As a general rule, the attenuation coefficient is doubled when the frequency is doubled.

$$I_{avg} = I_0 \exp\{-2\alpha z\}$$

Fyzikální základy - veličiny

Materiál	Rychlost zvuku c $\text{m}\cdot\text{s}^{-1}$	Hustota ρ $\text{kg}\cdot\text{m}^{-3}$	Akustická impedance Z $\text{kg}\cdot\text{m}^{-2}\cdot\text{s}^{-1} (\times 10^6)$	Koeficient absorpce α $\text{dB}\cdot\text{cm}^{-1}\cdot\text{MHz}^{-1}$
Vzduch	330	1,3	0,00043	
Tuk	1470	970	1,42	0,6
Ricínový olej	1500	933	1,40	
Voda	1492	1000	1,48	
Měkká tkáň	1500	<1000	~1,45	1,0
Mozek	1530	1020	1,56	0,85
Krev	1570	1020	1,60	0,18
Ledviny	1561	1030	1,61	
Játra	1549	1060	1,64	0,9
Sval	1568	1040	1,63	
Sval (podélná vlákna)			1,2	1,65
Sval (příčná vlákna)			3,3	1,65
Oční čočky	1620	1130	1,83	2,0
Kost	4080	1700	6,12	6,1
Plast			3,2	2,0

Introduction

Ultrasound acoustics

Waves

Wave equation

Reflection and refraction

Interface reflection

Attenuation

Medical ultrasound

Devices

Cardiologic US

Intravascular US

Artefacts

Generation/detection

Generation

Steering/Beamforming

Focusing

Processing and control

Medical ultrasound devices



Medical ultrasound devices



Medical ultrasound devices



Medical applications of ultrasound imaging

- Cardiology (heart)
- Gynecology: breast, fetus (pregnancy)
- Internal organs: liver, kidney, thyroid gland
- Intravascular ultrasound
- Therapeutic ultrasound: shock wave (kidney stone), thermal effects (rehabilitation)

Imaging modes

- A osciloscopic, intensity/time
- B 2D in the probe plane**
- C 2D perpendicular
- TM 1D+time
- Q Doppler (speed)

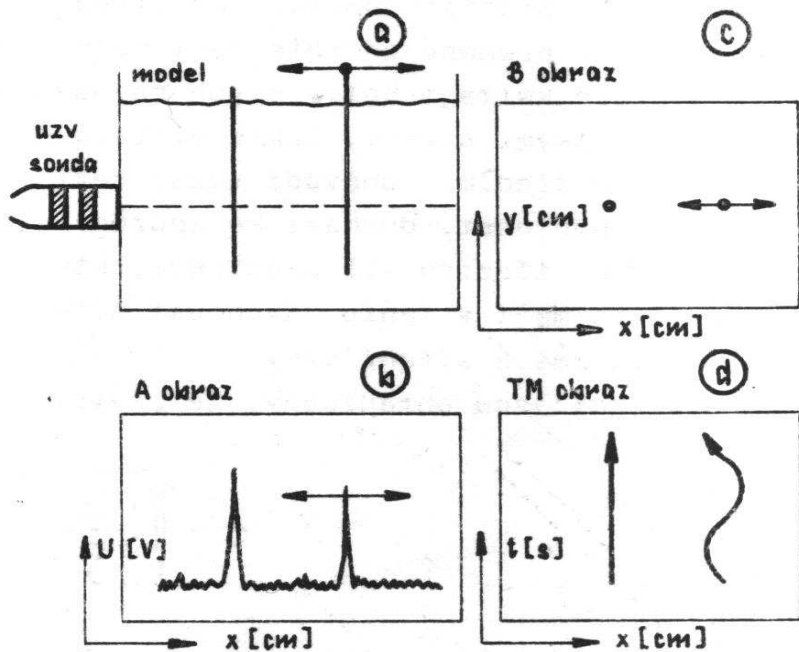

Introduction

Ultrasound acoustics

Waves

Wave equation

Reflection and refraction

Interface reflection

Attenuation

Medical ultrasound

Devices

Cardiologic US

Intravascular US

Artefacts

Generation/detection

Generation

Steering/Beamforming

Focusing

Processing and control

Conventional Cardiac 2D Ultrasound

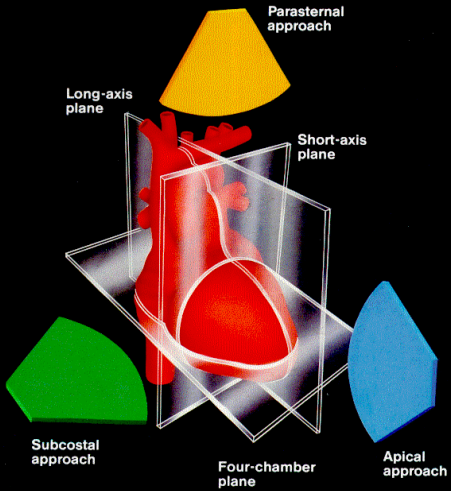

Heart

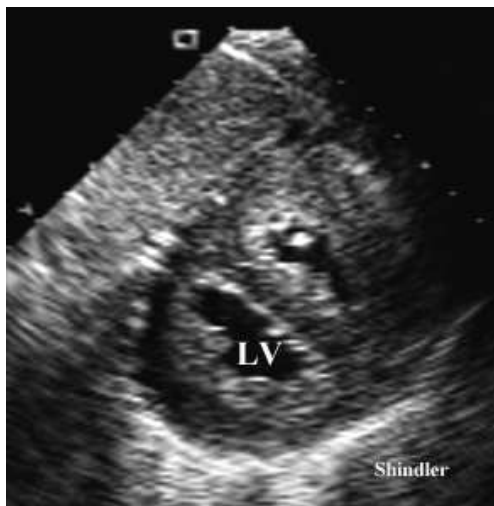

Heart

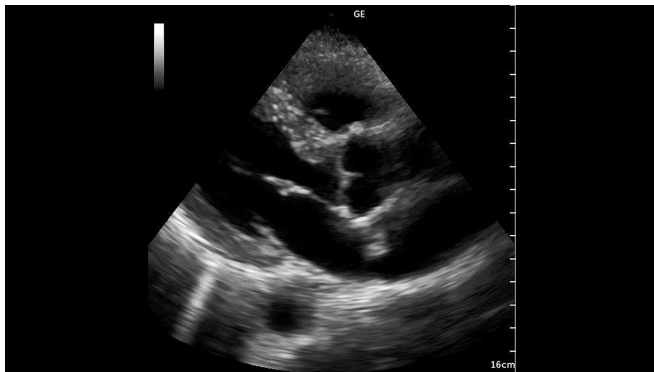

Heart

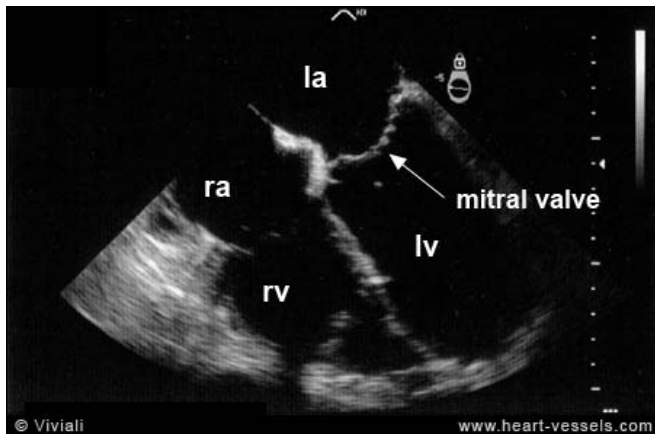

B-mode Image of Heart

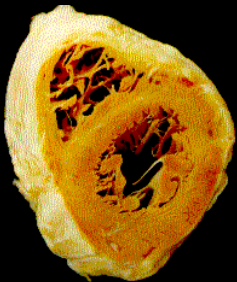

Traditional Ultrasound Images

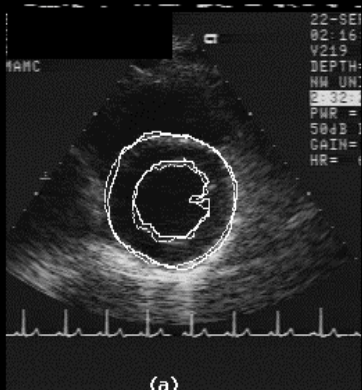

End-diastole

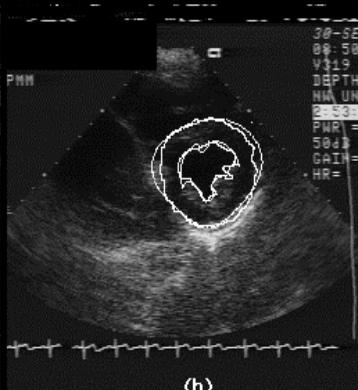

End-systole

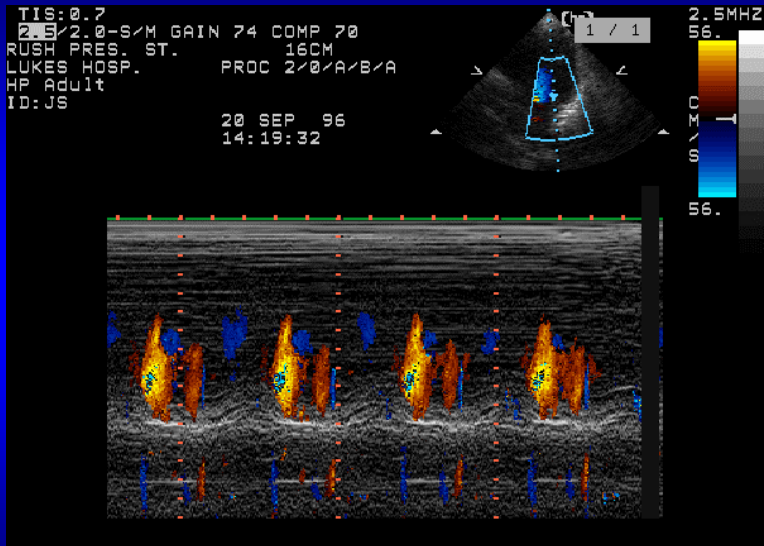

Introduction

Ultrasound acoustics

Waves

Wave equation

Reflection and refraction

Interface reflection

Attenuation

Medical ultrasound

Devices

Cardiologic US

Intravascular US

Artefacts

Generation/detection

Generation

Steering/Beamforming

Focusing

Processing and control

Progression of Vascular Disease

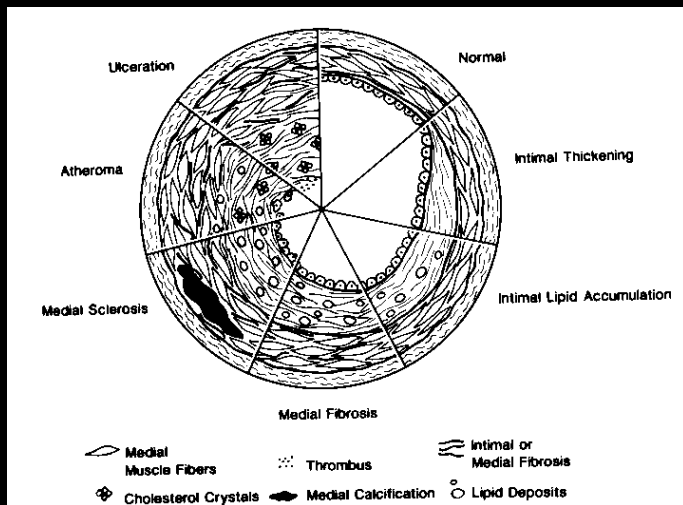

IVUS Catheter

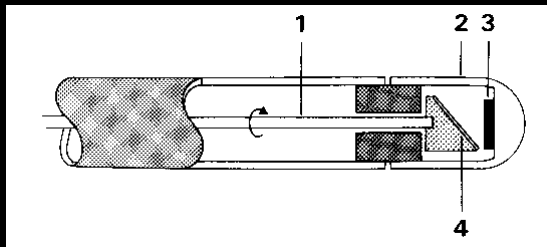

- 1 - Rotating shaft
- 2 - Acoustic window
- 3 - Ultrasound crystal
- 4 - Rotating beveled acoustic mirror

Slightly Diseased Artery in Cross-section

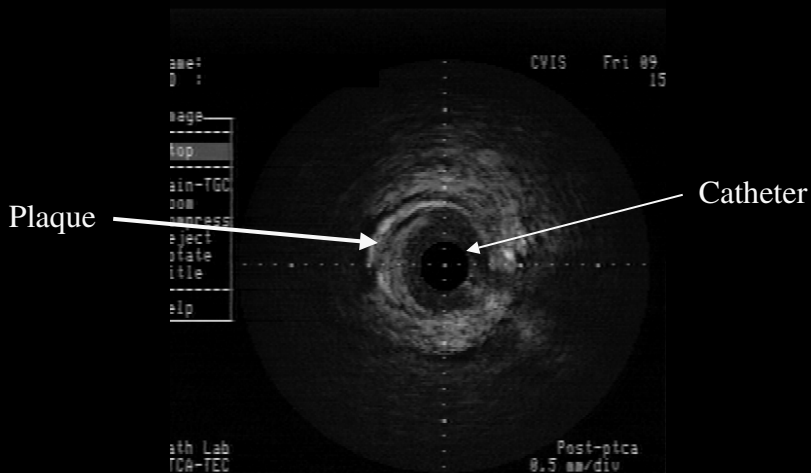

3D IVUS

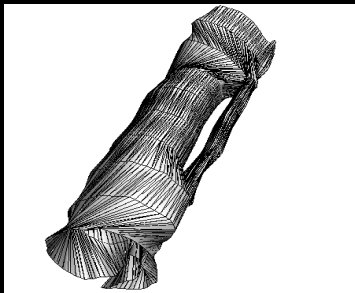
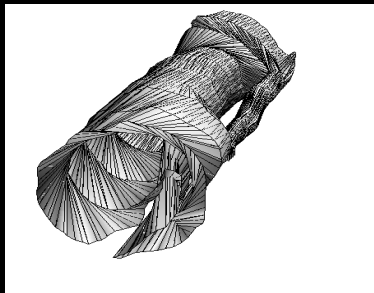

Other ultrasound examples



Other ultrasound examples

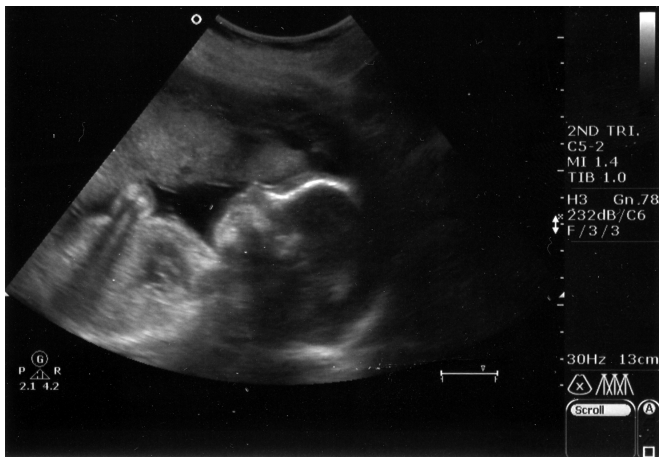

Other ultrasound examples



Introduction

Ultrasound acoustics

Waves

Wave equation

Reflection and refraction

Interface reflection

Attenuation

Medical ultrasound

Devices

Cardiologic US

Intravascular US

Artefacts

Generation/detection

Generation

Steering/Beamforming

Focusing

Processing and control

Geometrická distorze UZV zobrazení

- změnou rychlosti šíření UZV vlny,

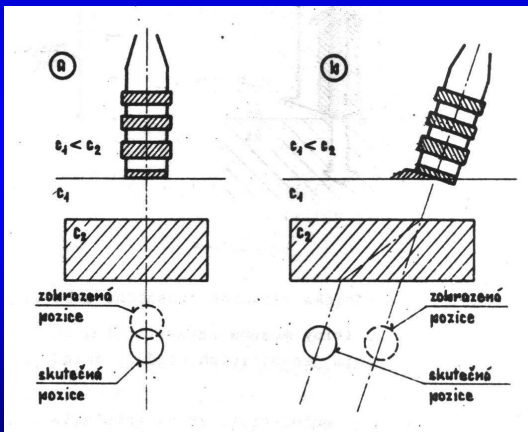

Geometrická distorze UZV zobrazení

- skladbou tkání,

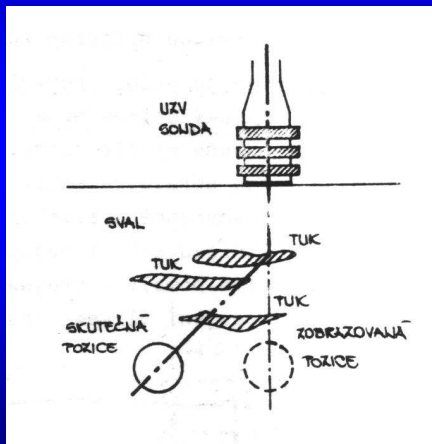

Geometrická distorze UZV zobrazení

- násobnou reflexí,

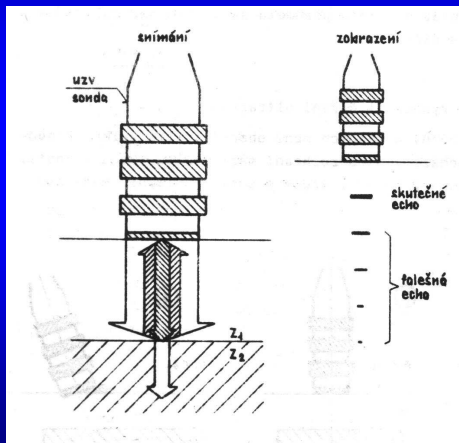

Geometrická distorze UZV zobrazení

- vlivem konečné šířky UZV svazku,

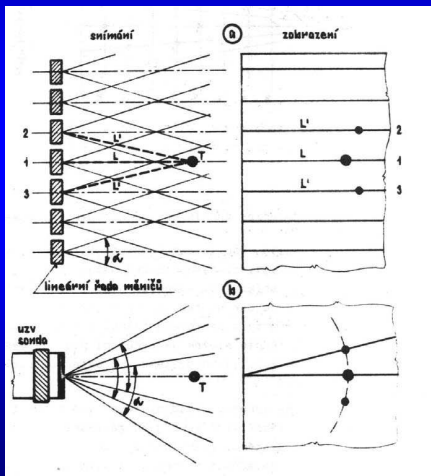

Geometrická distorze UZV zobrazení

- pohybem tkáňových struktur,

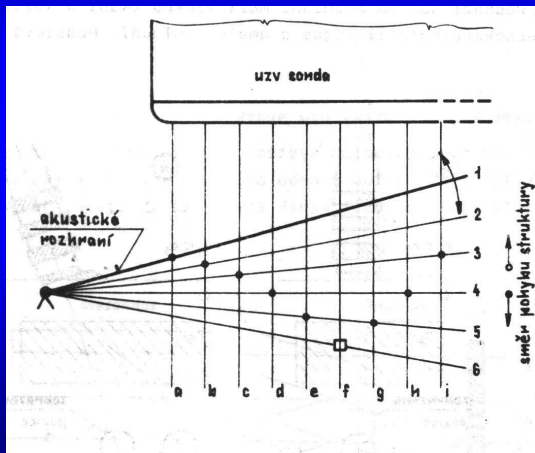

Introduction

Ultrasound acoustics

Waves

Wave equation

Reflection and refraction

Interface reflection

Attenuation

Medical ultrasound

Devices

Cardiologic US

Intravascular US

Artefacts

Generation/detection

Generation

Steering/Beamforming

Focusing

Processing and control

Generace a detekce UZV signálu

- požadavky na konstrukci systému,
 - generace UZV impulsu 10 až 100 mW/cm²,
 - vysoký dosažený odstup S/Š,
 - malá akustická vazba mezi jednotlivými měniči,
 - krátký generovaný impuls ~ 2μs,
 - vysoká účinnost přenosu energie mezi měniči,
 - tlumení zpětné akustické vlny,
 - dosažení širokého úhlového krytí snímaného pole,
 - potlačení vibrací,
 - lehká, snadno manipulovatelná konstrukce,
- princip vstupní jednotky digitálního sonografu,

Zdroje ultrazvukového vlnění

- zdrojem UZV vlnění UZV měnič v sondě,
- přímý a nepřímý piezoelektrický jev,
- charakteristickým parametrem sondy je rezonanční frekvence, určená tl. měniče,
- co nejkratší impuls při vysílání x velká citlivost,

Pressure Generation



- Piezoelectric crystal
- 'piezo' means pressure, so piezoelectric means
 - pressure generated when electric field is applied
 - electric energy generated when pressure is applied

Charged Piezoelectric Molecules

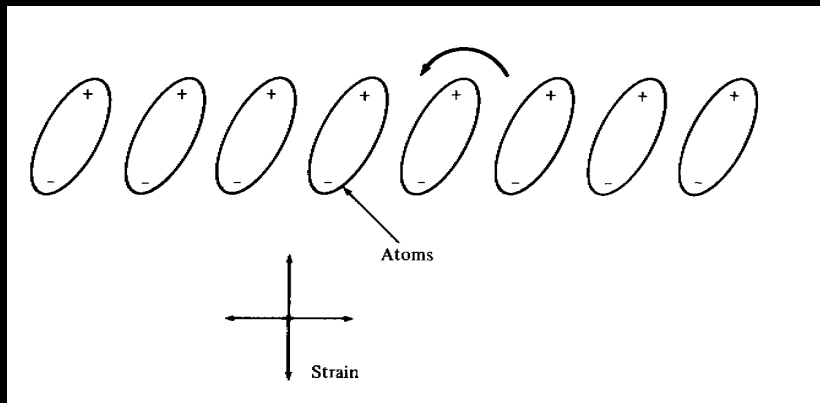

Highly simplified effect of E field

Piezoelectric Effect

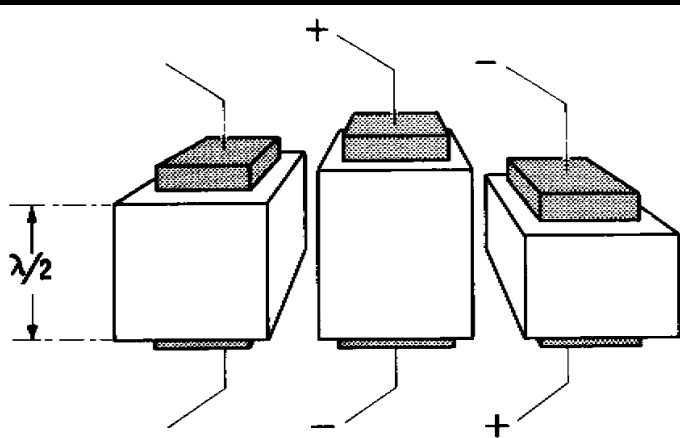

Zpracování UZV signálu

- přizpůsobení akustických impedancí

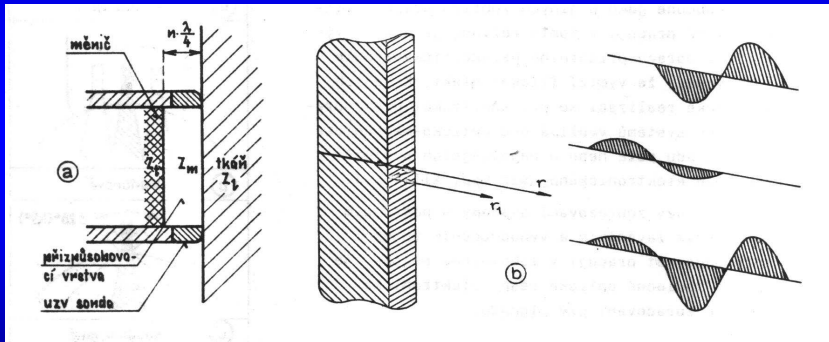

Transducer

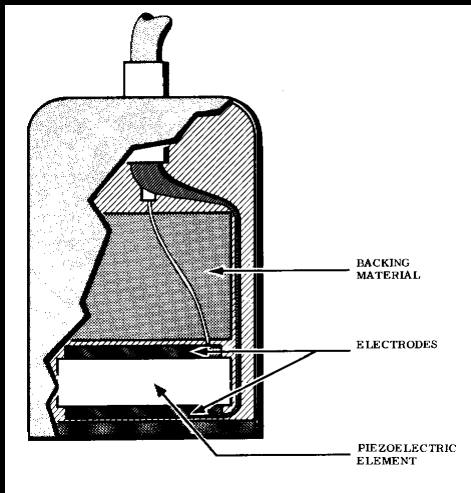

Pressure Radiated by Sharp Pulse

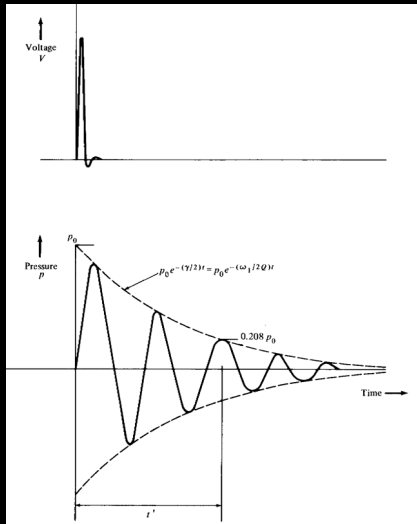

Zdroje ultrazvukového vlnění

- ultrazvukové pole,

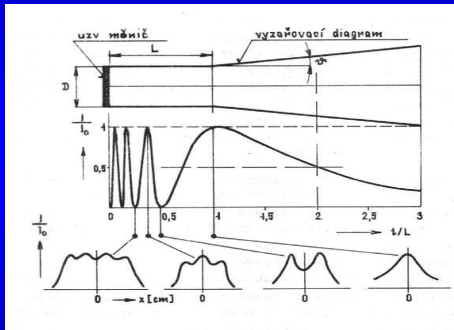

$$L = \frac{D^2 - \lambda^2}{4\lambda}$$

- blízké pole (blízká Fresnelova oblast),

- vzdálené pole (vzdálená Fraunhoferova oblast),

Zdroje ultrazvukového vlnění

- vyzařovací diagram sondy,

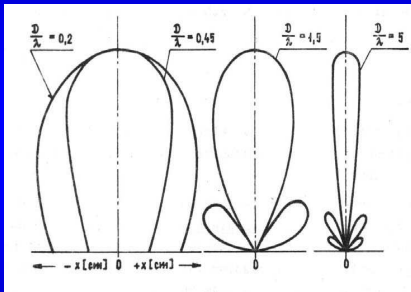

- Fraunhoferova formule,

$$\sin \vartheta = 1,22 \frac{\lambda}{D}$$

$$\sin \vartheta = \frac{\lambda}{b}$$

- významnou úlohu sehrává poměr $\frac{D}{\lambda}$,

- postranní laloky - tlumení x akustická vazba,

Rozlišovací schopnost

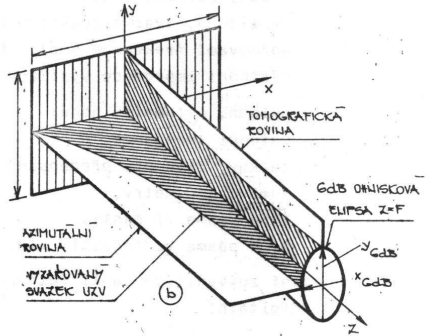
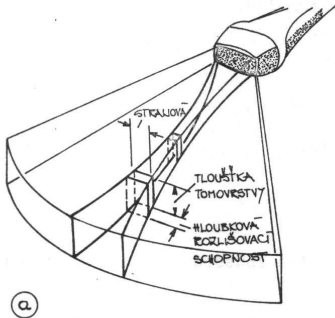

Introduction

Ultrasound acoustics

Waves

Wave equation

Reflection and refraction

Interface reflection

Attenuation

Medical ultrasound

Devices

Cardiologic US

Intravascular US

Artefacts

Generation/detection

Generation

Steering/Beamforming

Focusing

Processing and control

Zpracování UZV signálu

- vychylování UZV svazku - poziční jednotka
 - mech. systémy s lineárním snímáním,
 - mech. systémy se sektorovým snímáním,
 - rotační systém,
 - systém s kývající sondou,
 - elektronické systémy s lineárním snímáním,
 - elektronické systémy se sektorovým snímáním,
- fokuzace UZV svazku

UZV sonda s mech. rozkladem - Siemens

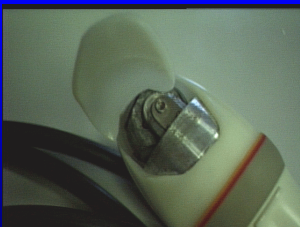
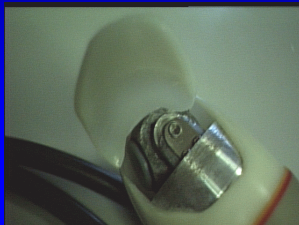
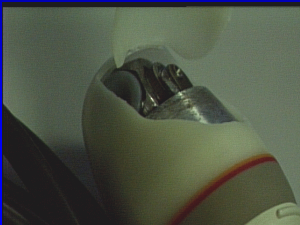

UZV sonda s mech. rozkladem - Siemens

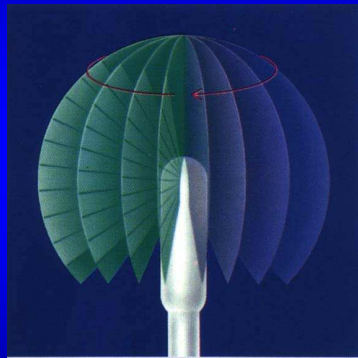
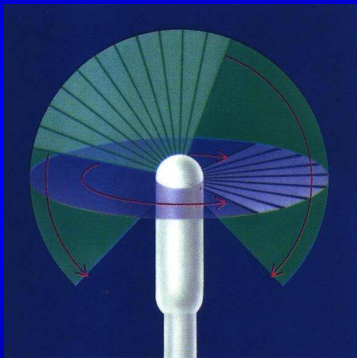

El. systémy s lineárním snímáním

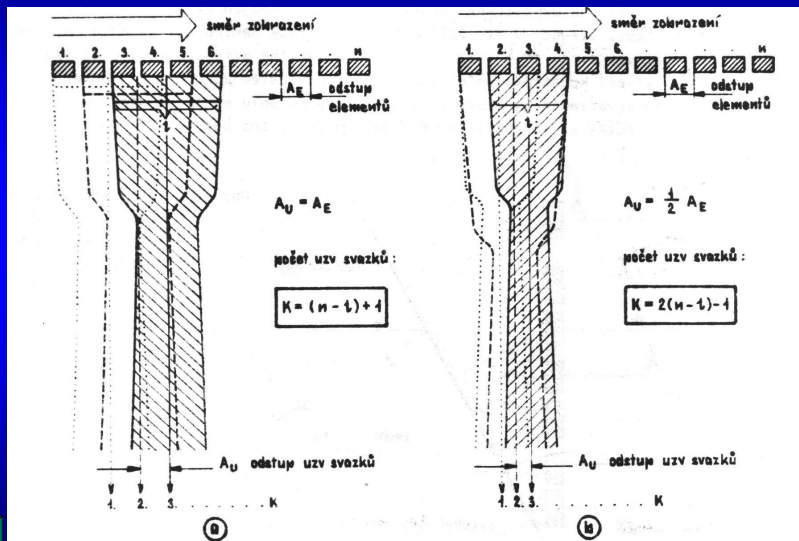

El. systémy se sektorovým snímáním

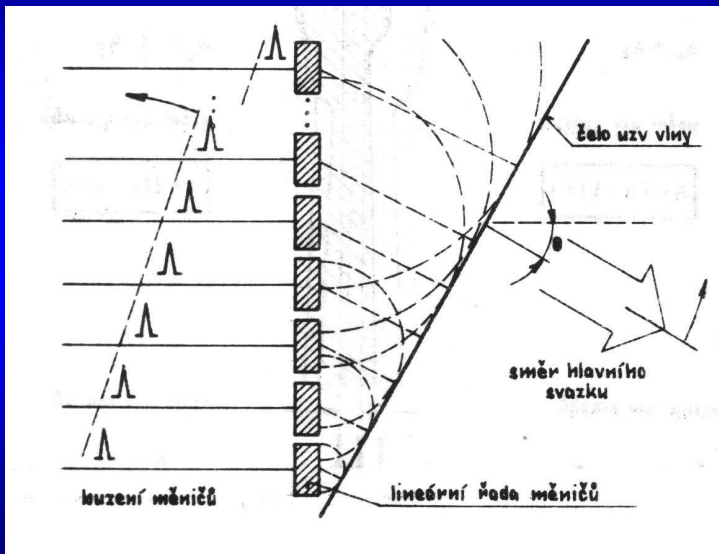

Introduction

Ultrasound acoustics

Waves

Wave equation

Reflection and refraction

Interface reflection

Attenuation

Medical ultrasound

Devices

Cardiologic US

Intravascular US

Artefacts

Generation/detection

Generation

Steering/Beamforming

Focusing

Processing and control

Fokuzace svazku UZV signálu - typy

- fokuzace UZV čočkou,
- fokuzace zrcadly,
- elektronická fokuzace,
 - statická,
 - s lineární řadou měničů,
 - v režimu vysílání,
 - v režimu příjmu,
 - velikostí apertury,
 - elektronicko-optická,
 - s anulární sondou,
 - dynamická,
 - v režimu vysílání,



Fokuzace čočkou

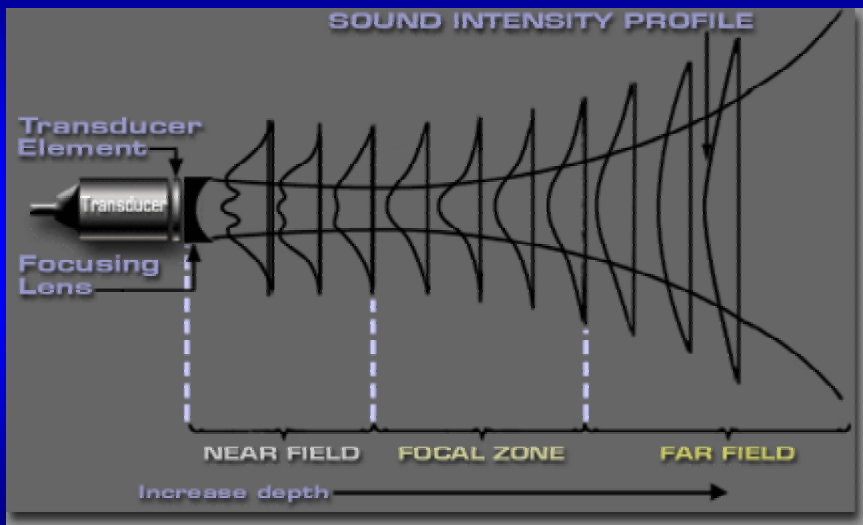

Fokuzace čočkou

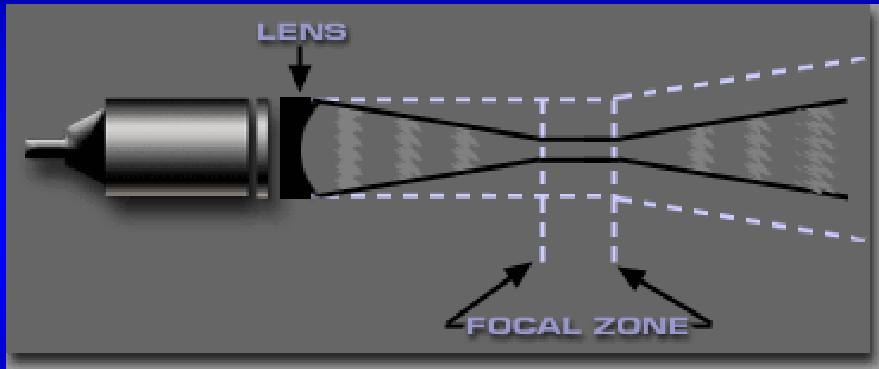

Fokuzace čočkou

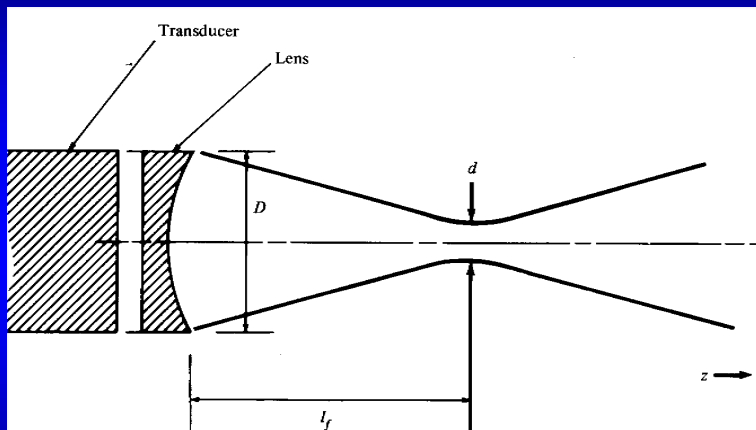

$$d = 2,44 \cdot \left(\frac{l_f}{D} \right) \cdot \lambda$$



El. fok. stat. s lin. řad. měn. v r. vysílání

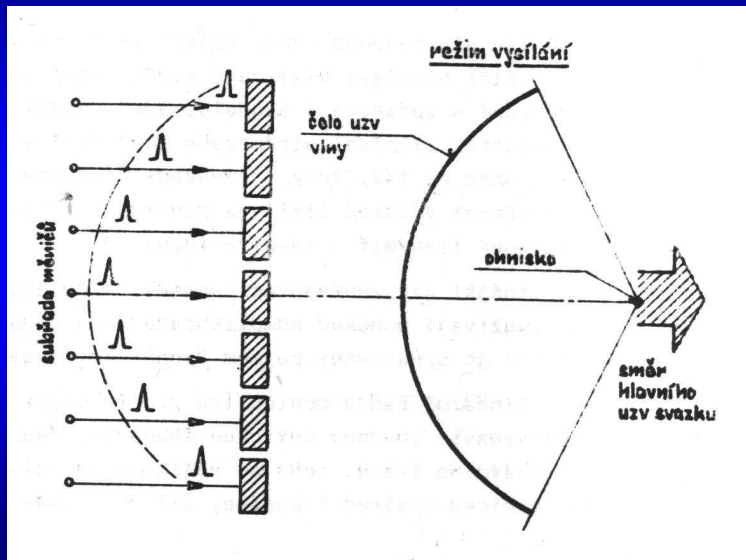

El. fok. stat. s lin. řad. měn. v r. příjmu

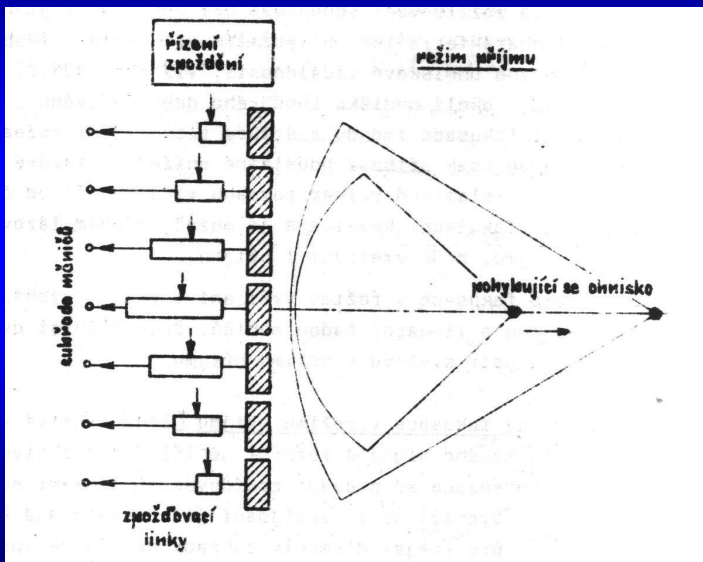

Phased Linear Array

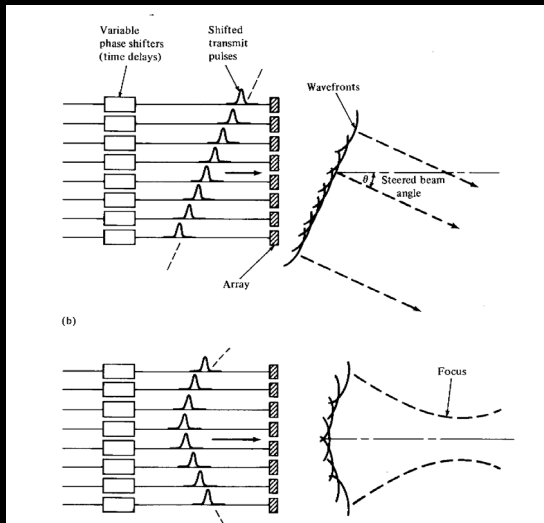

Beam Direction

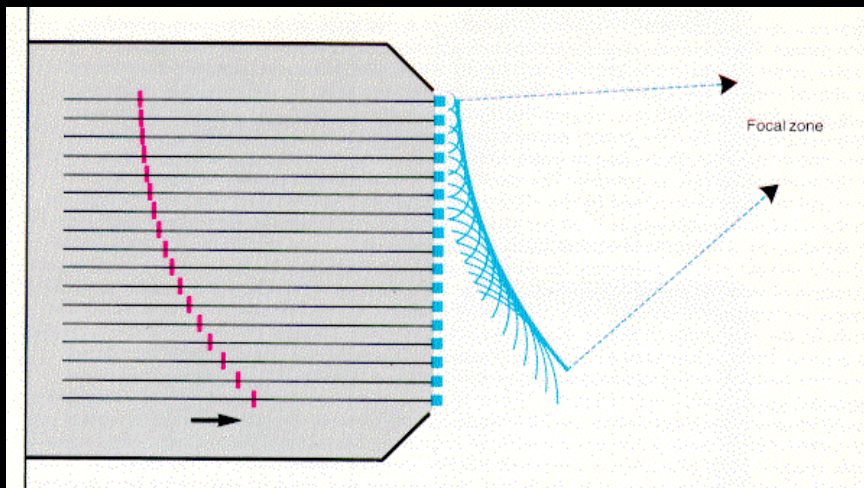

El.-optická fok. stat. s lin. řad. měn.

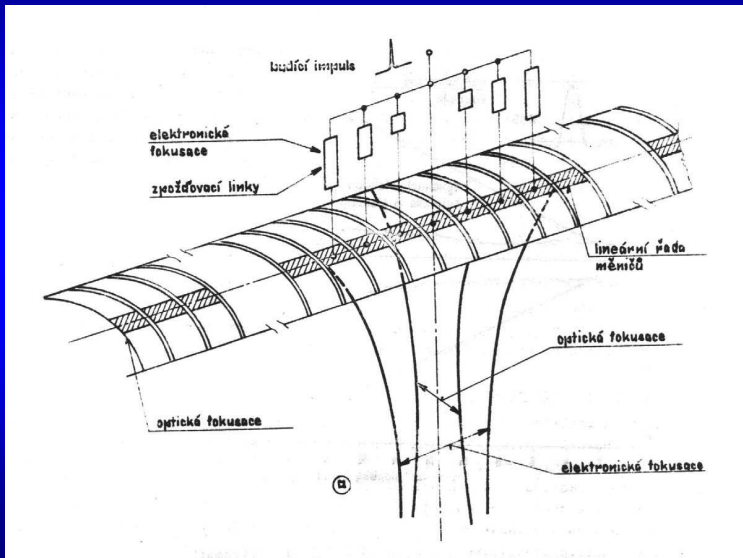

Introduction

Ultrasound acoustics

Waves

Wave equation

Reflection and refraction

Interface reflection

Attenuation

Medical ultrasound

Devices

Cardiologic US

Intravascular US

Artefacts

Generation/detection

Generation

Steering/Beamforming

Focusing

Processing and control

Zpracování elektrického sign. - B mód

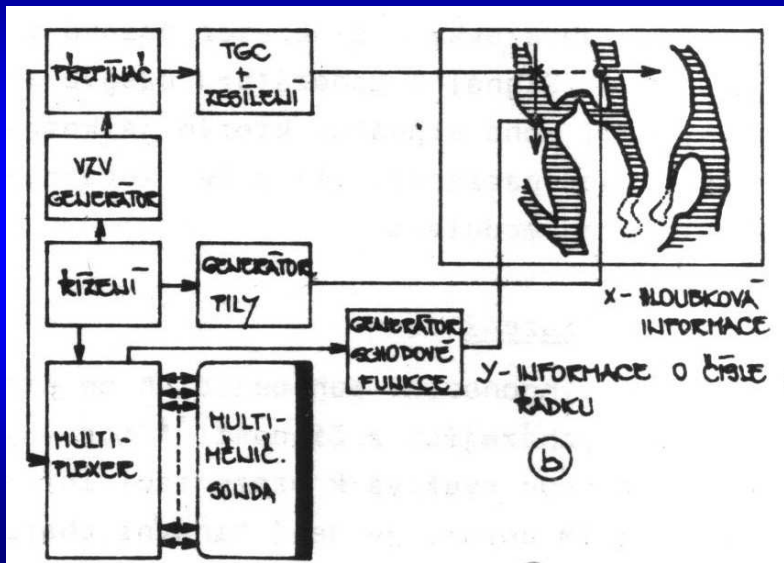

Zesilovače s časově řízeným zesílením

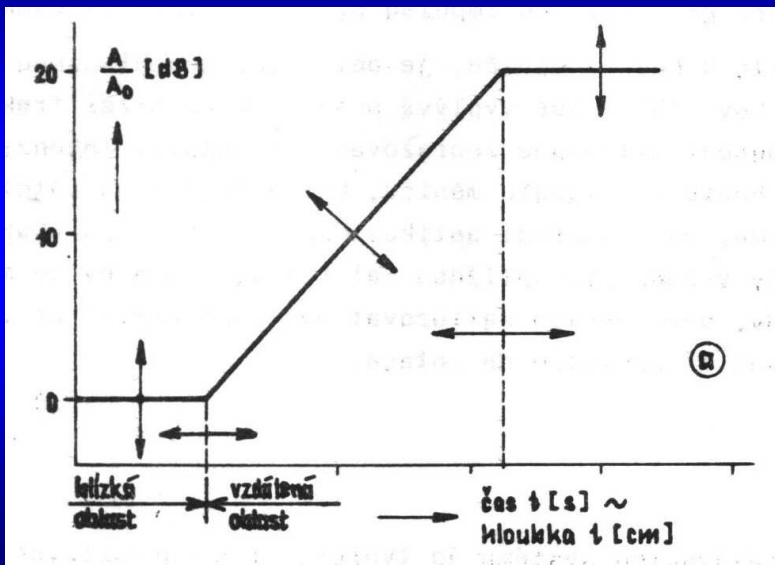

Amplitudově řízené zesilovače

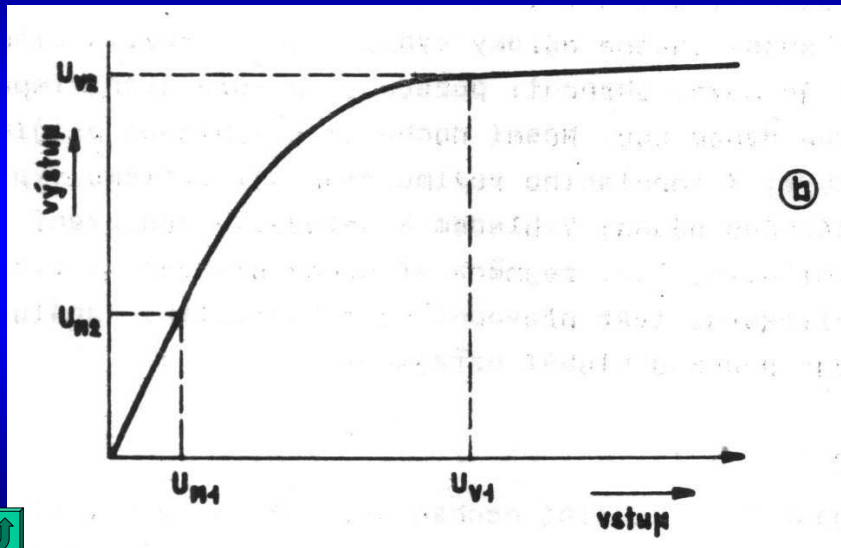

Geom. vztah sekt. sním. a TV zobr. rastru

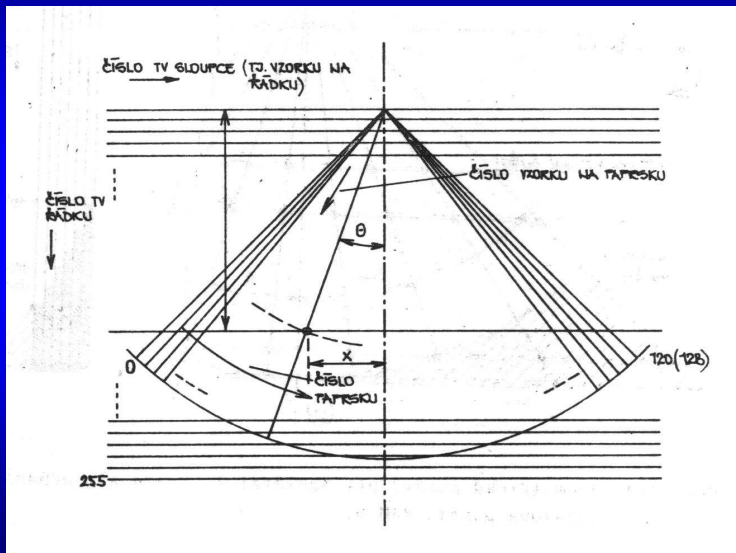

Part II

Modern ultrasound imaging

Doppler ultrasound

US contrast agents

Harmonic imaging

3D US imaging

DOPPLEROVSKÁ ULTRASONOGRAFIE

(principy přístrojů CW, PW, CDI)

Ing. Jiří Hozman

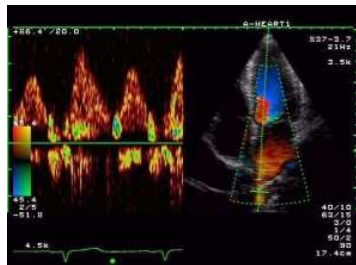
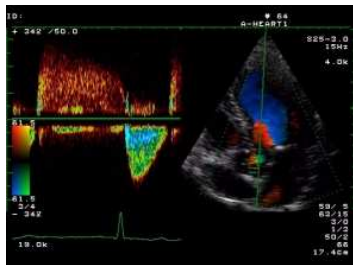

Christian Andreas Doppler

(rakouský fyzik a matematik)

*** 29.11.1803 Salzburg, Austria**

† 17.3.1853 Venice, Italy



1835 - počátek pobytu v Praze

1842 - formulace Dopplerova principu

1845 - experimentální ověření

1847 - konec pobytu v Praze

1. Stacionární zdroj a pohybující se přijímač

$$\lambda_s = \frac{c}{f_s}$$

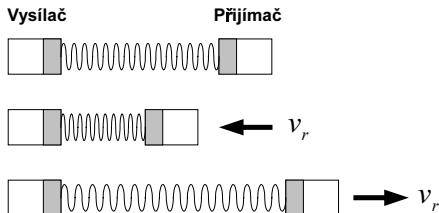

Dopplerova frekvence

$$f_r = f_s + \frac{v_r}{\lambda_s} = f_s + \left(\frac{v_r}{c} \right) f_s \qquad f_D = \left(\frac{v_r}{c} \right) f_s$$

2. Stacionární přijímač a pohybující se zdroj

$$\lambda_s = \frac{c}{f_s}$$

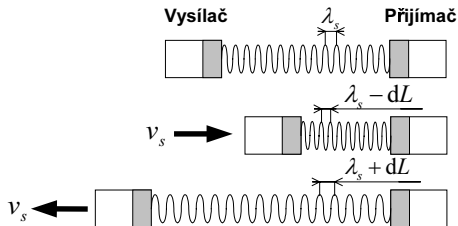

$$dL = v_s \left(\frac{1}{f_s} \right)$$

$$\lambda_r = \lambda_s - dL = \frac{c}{f_s} - \frac{v_s}{f_s} = \frac{c}{f_r}$$

$$f_r = \frac{c}{c - v_s} f_s = \frac{1}{1 - \frac{v_s}{c}} f_s$$

Použitím rozvoje do Taylorovy řady

$$\frac{1}{1 - x} = 1 + x + \frac{x^2}{2} + \dots$$

Všechny členy s x^2 a vyšší mocninou zanedbáme a protože $v/c \ll 1$ můžeme psát

$$f_r = \left(1 + \frac{v_s}{c}\right) f_s \quad \text{Dopplerova frekvence} \quad f_D = \left(\frac{v_s}{c}\right) f_s$$

Blood flow speed measurement

- Doppler effect: Frequency changes if the source moves with respect to the receiver.
- Reflection from red blood cells
- Red blood cells
 - Moving receiver
 - Moving source
- Doppler shift

$$f_r = f_t + f_d \quad f_d \approx 2 \frac{v}{c} f_c$$

- We only measure the projection along the ray.

Demodulace Dopplerova signálu

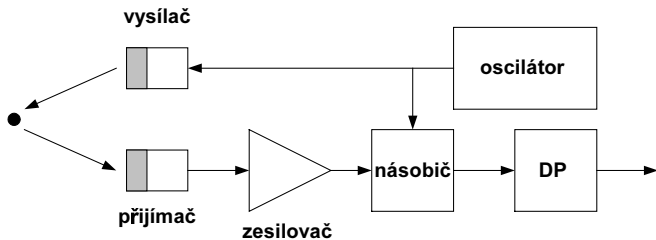

vysílaný signál

$$E \cos(\omega_c t)$$

přijatý signál

$$V_i = A \cos(\omega_c t + \Phi) + B \cos(\omega_c + \omega_D)t$$

Výsledkem násobení v demodulátoru je

$$V_A = AE \cos(\omega_c t + \Phi) \cos(\omega_c t) + BE \cos(\omega_c + \omega_D) t \cos(\omega_c t)$$

$$= \left(\frac{AE}{2} \right) \boxed{\cos(2\omega_c t + \Phi)} + \boxed{\cos(\Phi)} + \left(\frac{BE}{2} \right) \boxed{\cos(2\omega_c t + \omega_D t)} + \boxed{\cos(\omega_D t)}$$

Jednotlivé složky ve výše uvedeném vztahu znamenají:

$\boxed{\cos(2\omega_c t + \Phi)}$ potlačení
dvojnásobek vysílané frekvence (DP)

$\boxed{\cos(2\omega_c t + \omega_D t)}$ potlačení
dvojnásobek vysílané frekvence (DP)

$\boxed{\cos(\Phi)}$ potlačení
stejnoseměrná složka (HP)

$\boxed{\cos(\omega_D t) = \cos(-\omega_D t)}$ **Dopplerův signál, nelze určit směr**



Směrové demodulační systémy

Základní myšlenka

Převést směrovou informaci, danou znaménkem frekvenčního posuvu na jiný indikátor směru, který by po demodulaci zůstal zachován

Příklad

Pro vysílanou frekvenci 5 MHz a frekvenci Dopplerova signálu 5,8 kHz musíme odlišit kladný směr toku krve, tj. 5,0058 MHz a záporný směr toku krve, tj. 4,9942 MHz.

Základní uspořádání směrového demodulátoru

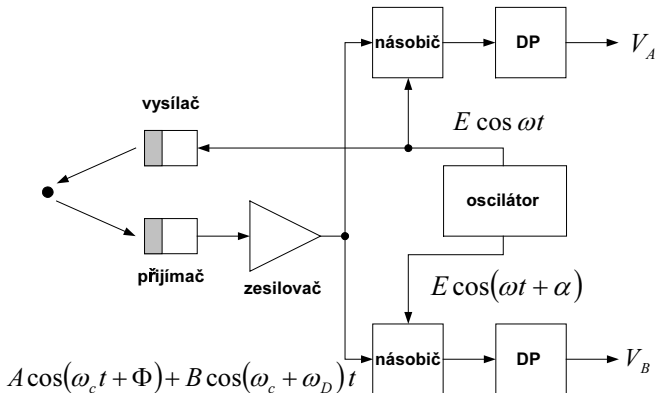

Fázové zpracování kvadrturních signálů V_A a V_B

$$V_A = \frac{1}{2}BE \cos(\omega_D t) \quad V_B = \frac{1}{2}BE \cos(\omega_D t - \alpha)$$

fázový posuv $\alpha = \pi/2 \rightarrow \sin$ a $\cos \rightarrow$ kvadrturní signály

Pokud zanedbáme amplitudy, pak dostaneme

$$V_A = \cos \omega_D t \quad V_B = -\sin \omega_D t$$

forward flow (dopředný tok) - od sondy, tj. $\omega_f = -\omega_D$

reverse flow (zpětný tok) - k sondě, tj. $\omega_r = \omega_D$

$$V_A = \cos \omega_f t + \cos \omega_r t \quad V_B = \sin \omega_f t - \sin \omega_r t$$

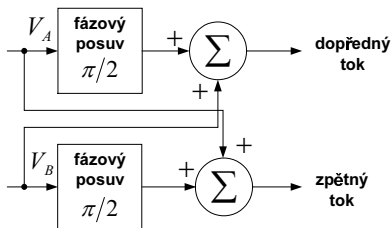

$$\cos \omega_f t + \cos \omega_r t \quad 0 \quad \rightarrow \quad \cos \omega_f t + \cos \omega_r t \quad (1)$$

$$\cos \omega_f t + \cos \omega_r t \quad \pi/2 \quad \rightarrow \quad \sin \omega_f t + \sin \omega_r t \quad (2)$$

$$\sin \omega_f t - \sin \omega_r t \quad 0 \quad \rightarrow \quad \sin \omega_f t - \sin \omega_r t \quad (3)$$

$$\sin \omega_f t - \sin \omega_r t \quad \pi/2 \quad \rightarrow \quad -\cos \omega_f t + \cos \omega_r t \quad (4)$$

$$(2) + (3) = \sin \omega_f t$$

$$(1) + (4) = \cos \omega_r t$$



Úplný systém k separaci signálové složky odpovídající dopřednému a zpětnému toku ve frekvenční oblasti

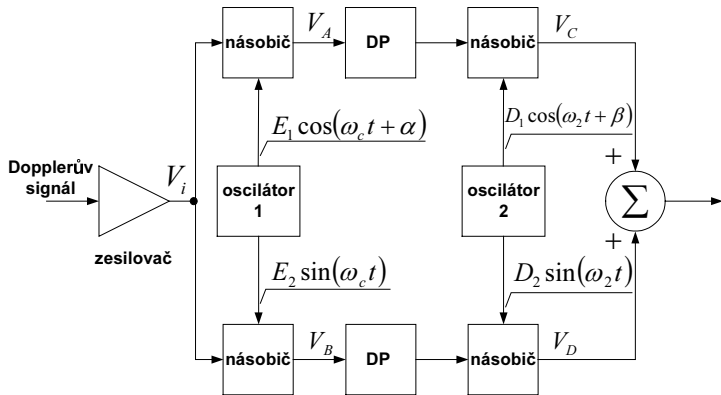

Hlavní myšlenka - posun nulové frekvence, tj. nulové rychlosti na jinou frekvenci ω_2

α a β představují chybu ve fázovém rozdílu

$$V_i = \boxed{A \cos(\omega_c t + \Phi)} + \boxed{B \cos(\omega_c + \omega_D)t}$$

signál nosné
Dopplerův signál

$$V_A = \frac{1}{2} B E_1 \cos(\omega_D t - \alpha) \quad V_B = -\frac{1}{2} B E_2 \sin(\omega_D t)$$

$$V_C = (B E_1 D_1 / 2) \cos(\omega_D t - \alpha) \cos(\omega_2 t + \beta)$$

$$V_C = \frac{1}{4} B E_1 D_1 [\cos(\omega_D t + \omega_2 t - \alpha + \beta) + \cos(\omega_D t - \omega_2 t - \alpha - \beta)]$$

Kontinuální Dopplerovské systémy CW

- kontinuální vysílání i příjem,
- v sondě dva piezo-elementy,
- vzorkovací objem dán šířkou UZ svazku,
- možnost detekovat velké rychlosti průtoku,
- nerozliší hloubku - množství spektrálních složek.



Pulzní Dopplerovské systémy PW (Pulsed Wave)

- pulzní vysílání i příjem,
- v sondě jeden piezo-element,
- vzorkovací objem dán délkou pulzu,
- omezení rozsahu detekovaných rychlostí průtoku,
- rozliší hloubku - méně spektrálních složek.

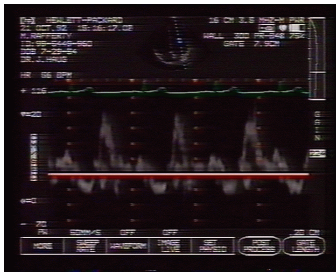

Omezení rozsahu detekovaných rychlostí průtoku u PW

$$\Phi = f_c T_D \quad \frac{d\Phi}{dt} = f_c \frac{T_D}{dt} \quad T_D = \frac{2z}{c}$$

$$\frac{dT_D}{dt} = \frac{2}{c} \frac{dz}{dt} = \frac{2v}{c} \quad f_D = \frac{d\Phi}{dt} = f_c \frac{T_D}{dt} = f_c \frac{2v}{c}$$

$$T_p = \frac{1}{f_p}$$

$$f_{D_{\max}} = \frac{1}{2T_p} = \frac{2v_{\max}}{c} f_c \quad \text{dáno } f_{\text{Nyquist}}$$

$$z_{\max} = \frac{c}{2} T_p$$

$$T_p = \frac{c}{4v_{\max} f_c} = \frac{2z_{\max}}{c}$$

$$v_{\max} z_{\max} = \frac{c^2}{8f_c}$$

Typický příklad

$$f_c = 2\text{MHz} \quad c = 1500\text{ms}^{-1} \quad v_{\max} z_{\max} = 0,14\text{m}^2\text{s}^{-1}$$

Ve vzdálenosti 10cm můžeme naměřit maximální rychlost

$$1,4\text{ms}^{-1}$$

$$v_{\max} = \frac{c^2}{8f_c z_{\max}}$$

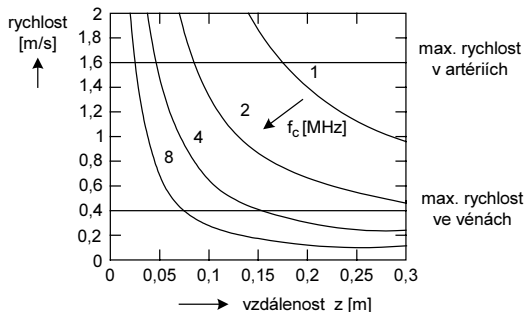

Doppler US — examples

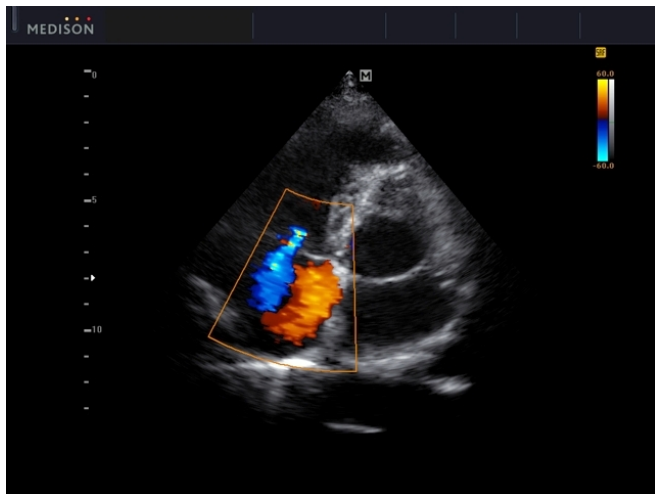

Doppler US — examples

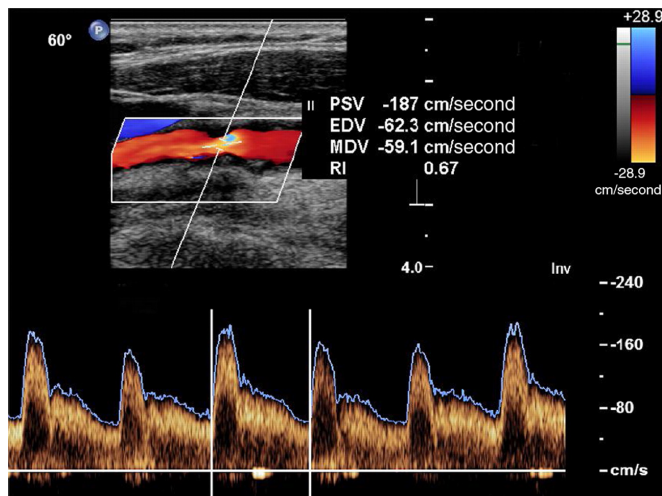

Doppler US — examples

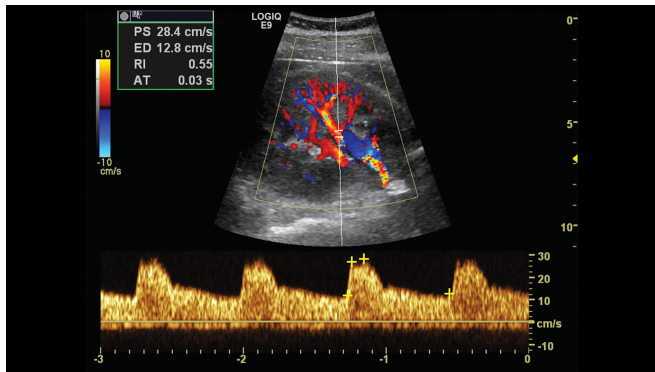

Doppler ultrasound

US contrast agents

Harmonic imaging

3D US imaging

Contrast agents

- 1968, *Gramiak, saline injection*
- Mikrobubbles ($2 \sim 5 \mu\text{m}$)
- Asymmetric compression/expansion
- Stabilization (synthetic polymers), up to 5 – 10 min.
- Injection.
- Albutex, Optison, Echovist, Levovist. . .

Flash Contrast Imaging

US bubble destabilization.

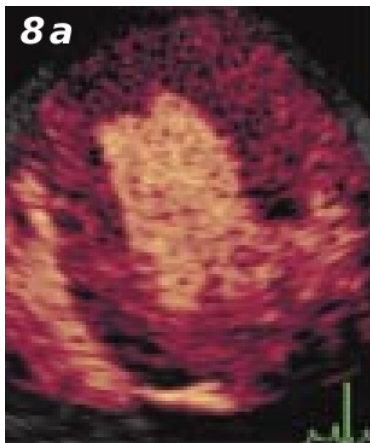

normal

Flash Contrast Imaging

US bubble destabilization.

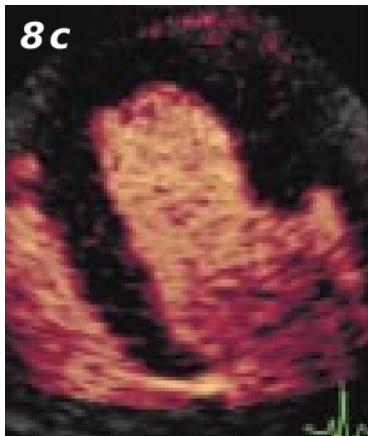

flash, bubbles broken

Flash Contrast Imaging

US bubble destabilization.



filling up

Myocardial perfusion evaluation.

Doppler ultrasound

US contrast agents

Harmonic imaging

3D US imaging

Nonlinear response

Assymmetric bubble compression

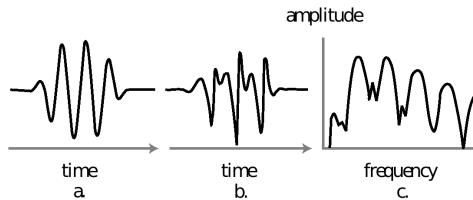

Harmonic imaging

- Transmit f_0 , receive $2f_0$



standard US

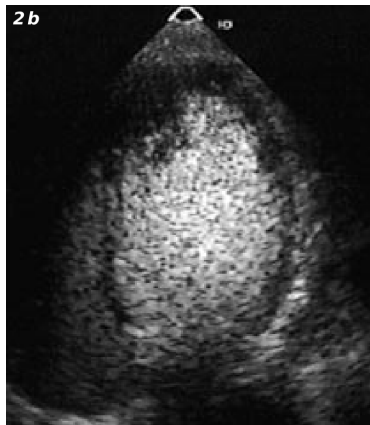

2nd harmonic

Harmonic imaging

- Transmit f_0 , receive $2f_0$
- Bandwidth limitation



standard US

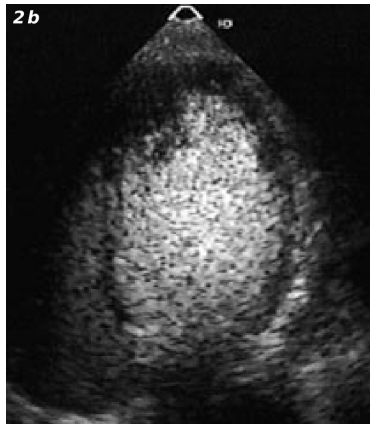

2nd harmonic

Harmonic imaging

- Transmit f_0 , receive $2f_0$
- Bandwidth limitation
- Bubbles not needed, tissue nonlinearity



standard US

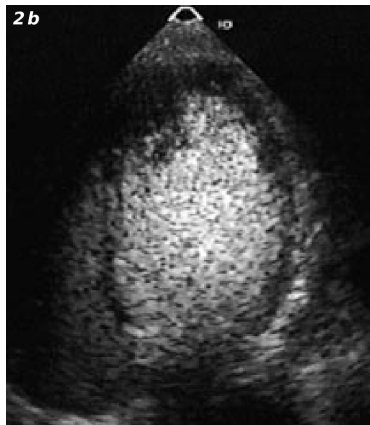

2nd harmonic

Pulse Inversion Harmonic Imaging

- Two pulses, second inverted
- Responses summed
- Filtration not needed

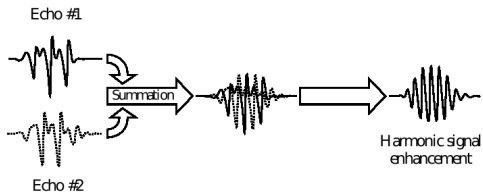
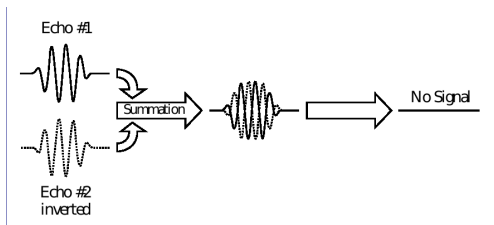

Pulse Inversion Harmonic Imaging

- Two pulses, second inverted
- Responses summed
- Filtration not needed

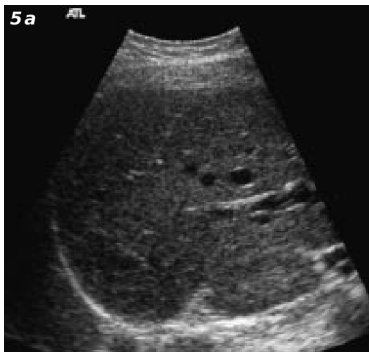

standard image (liver)

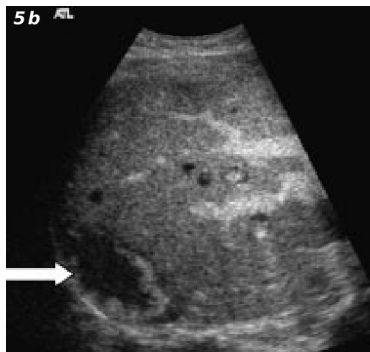

pulse inversion

Pulse Inversion Harmonic Imaging

- Two pulses, second inverted
- Responses summed
- Filtration not needed
- Several pulses (Power Pulse Inversion)

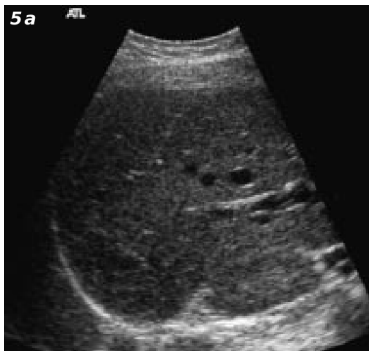

standard image (liver)

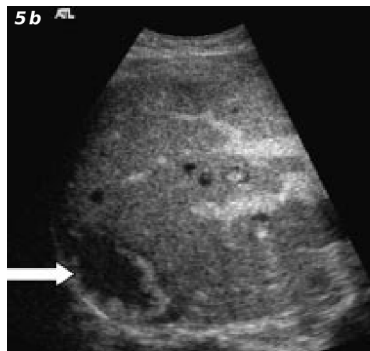

pulse inversion

Doppler ultrasound

US contrast agents

Harmonic imaging

3D US imaging

3D Reconstruction

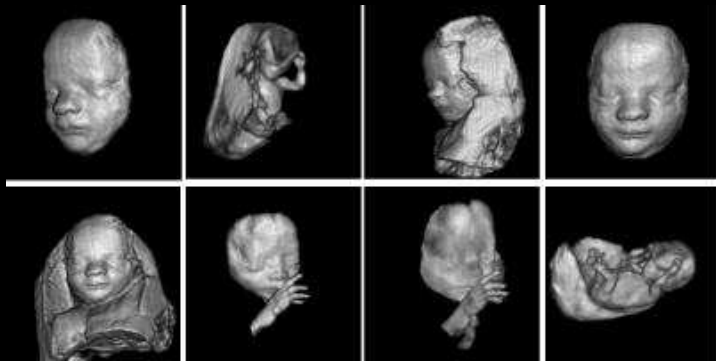

3D Ultrasound

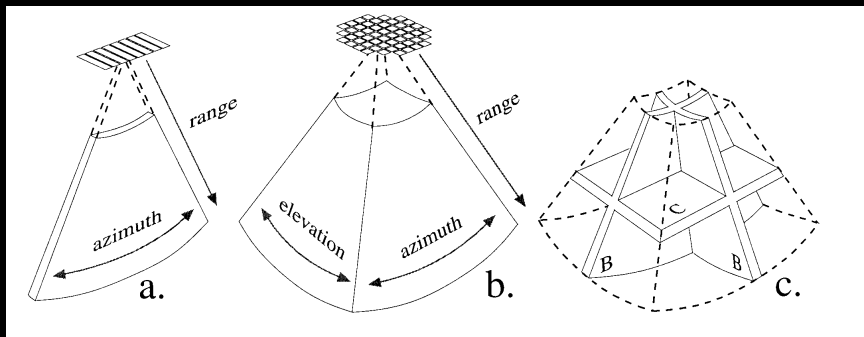

Traditional 2D

New 3D

Real-time 3D Ultrasound

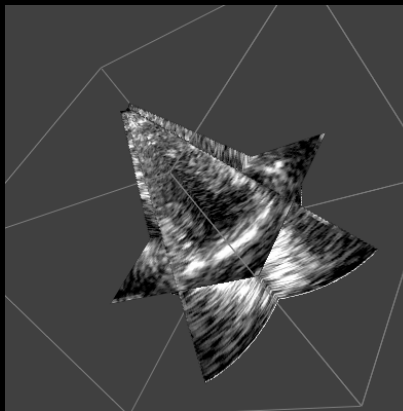
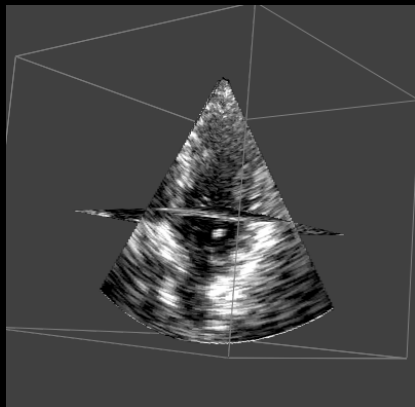

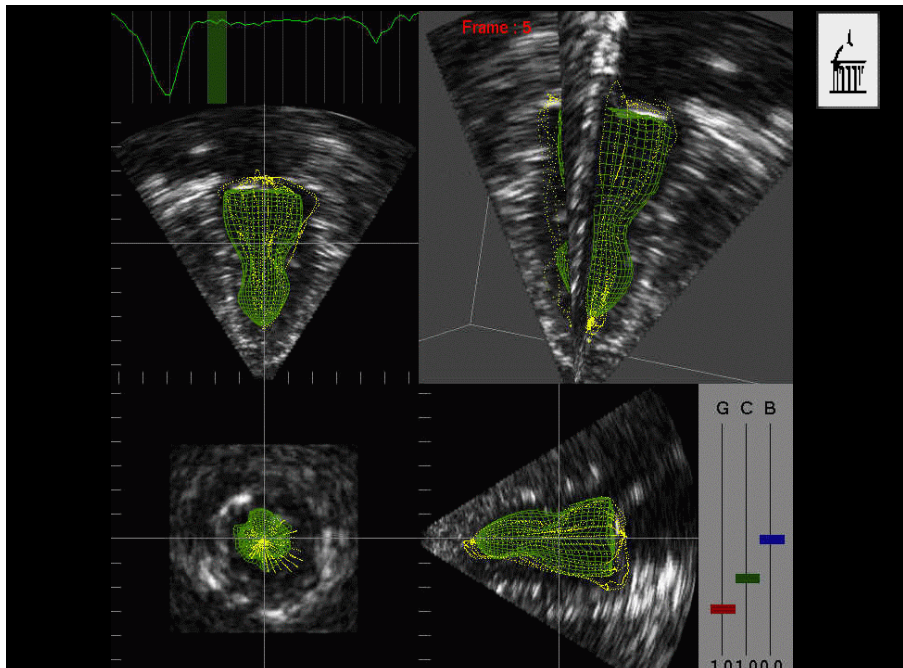

Velocity of Contraction

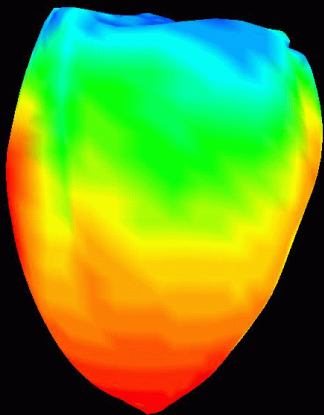

Normal

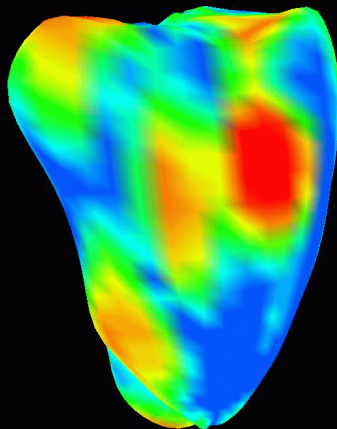

Abnormal

Conclusions

- Non-invasive, affordable and portable imaging technique
- Excellent soft tissue imaging
- Lower image quality (wrt CT or MRI) due to speckle but improving
- Low penetration depth versus resolution
- Does not pass through air or gas
- Does not pass through bones, shadows
- Modern techniques — 3D, contract agents, Doppler