

MASH robotic cell
Top view

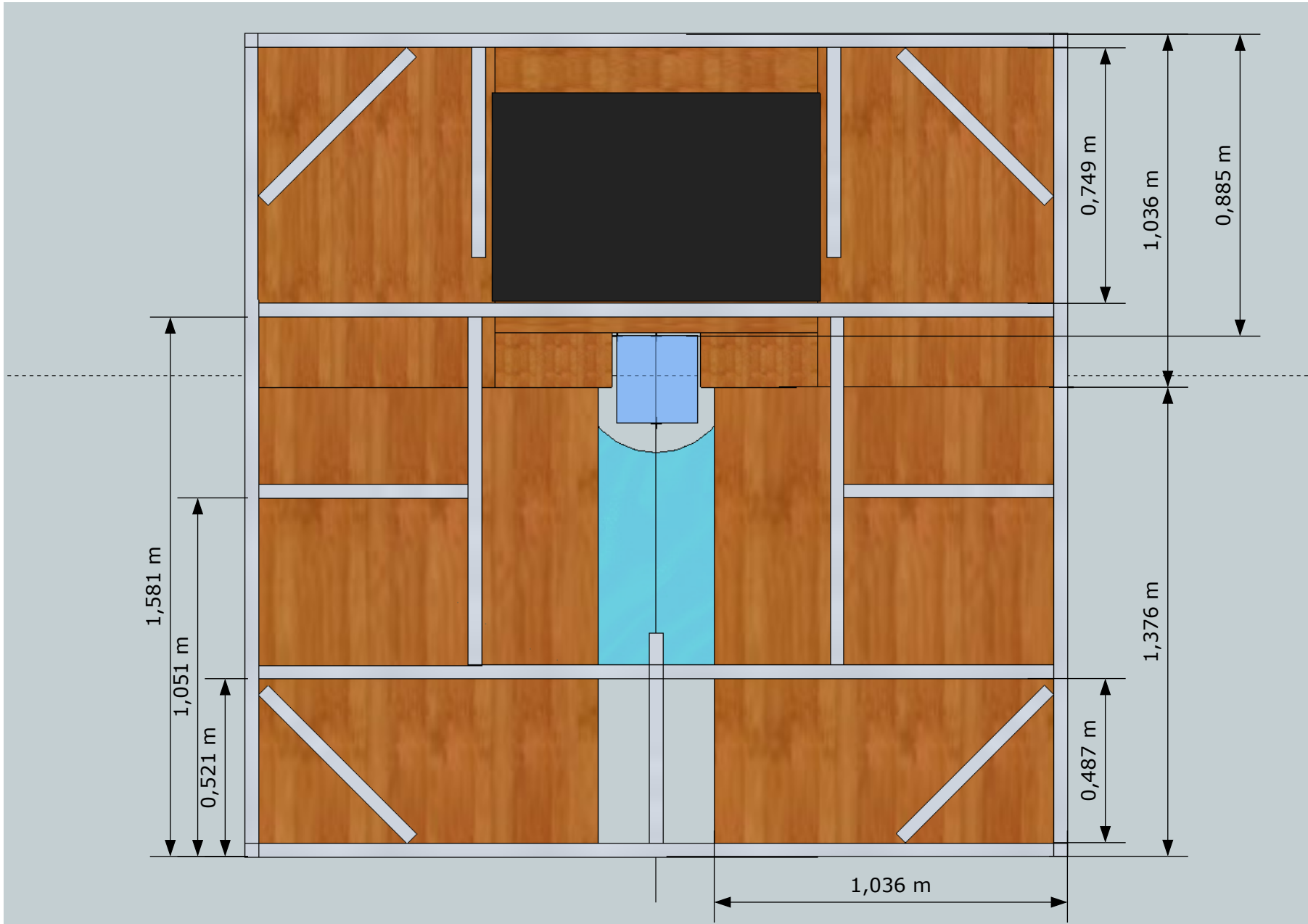

MASH robotic cell
Bottom view

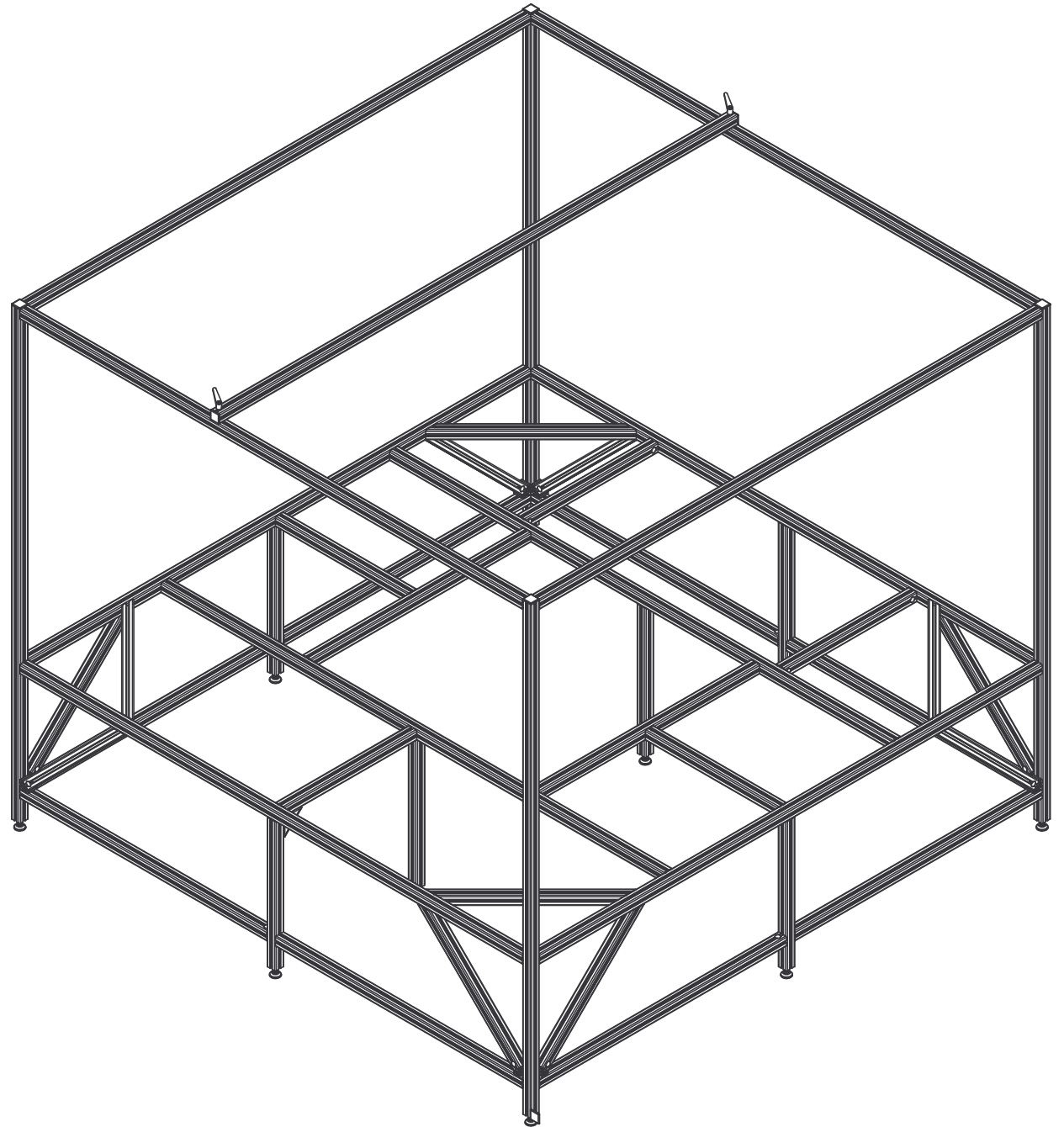

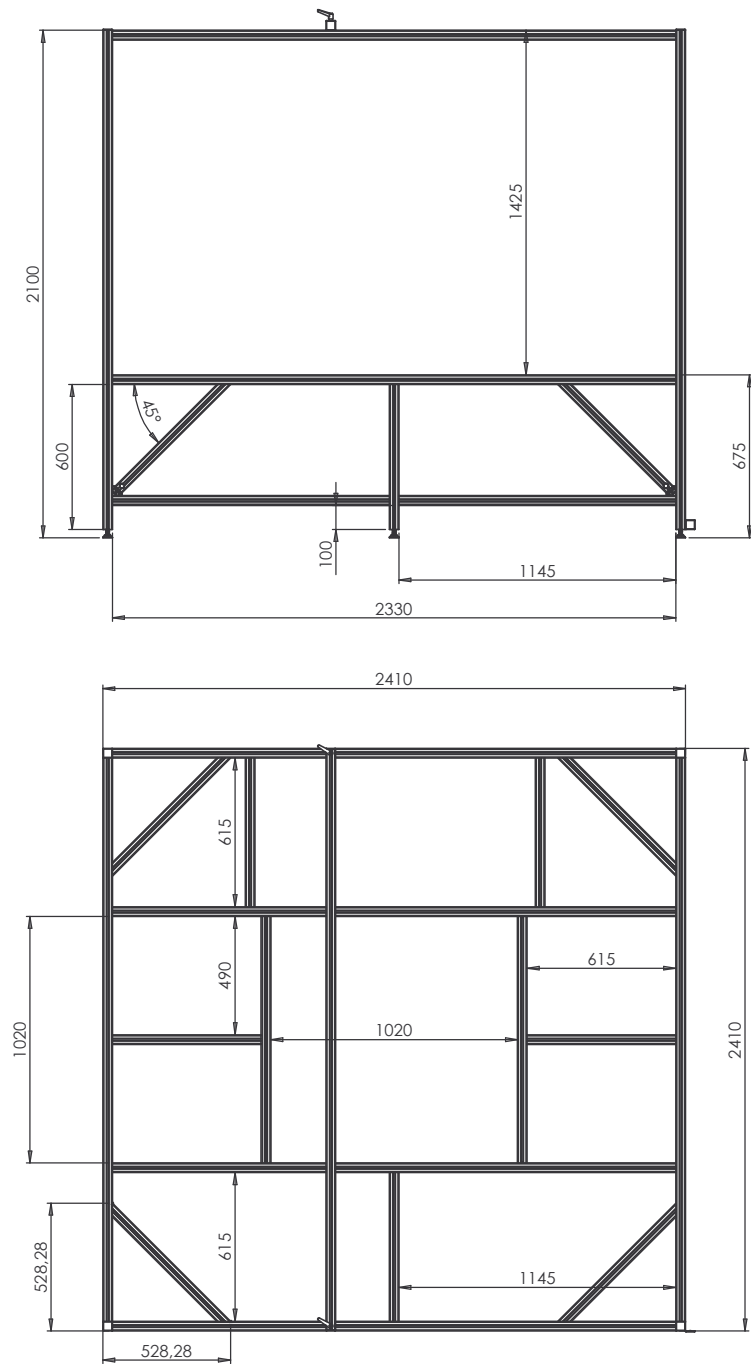
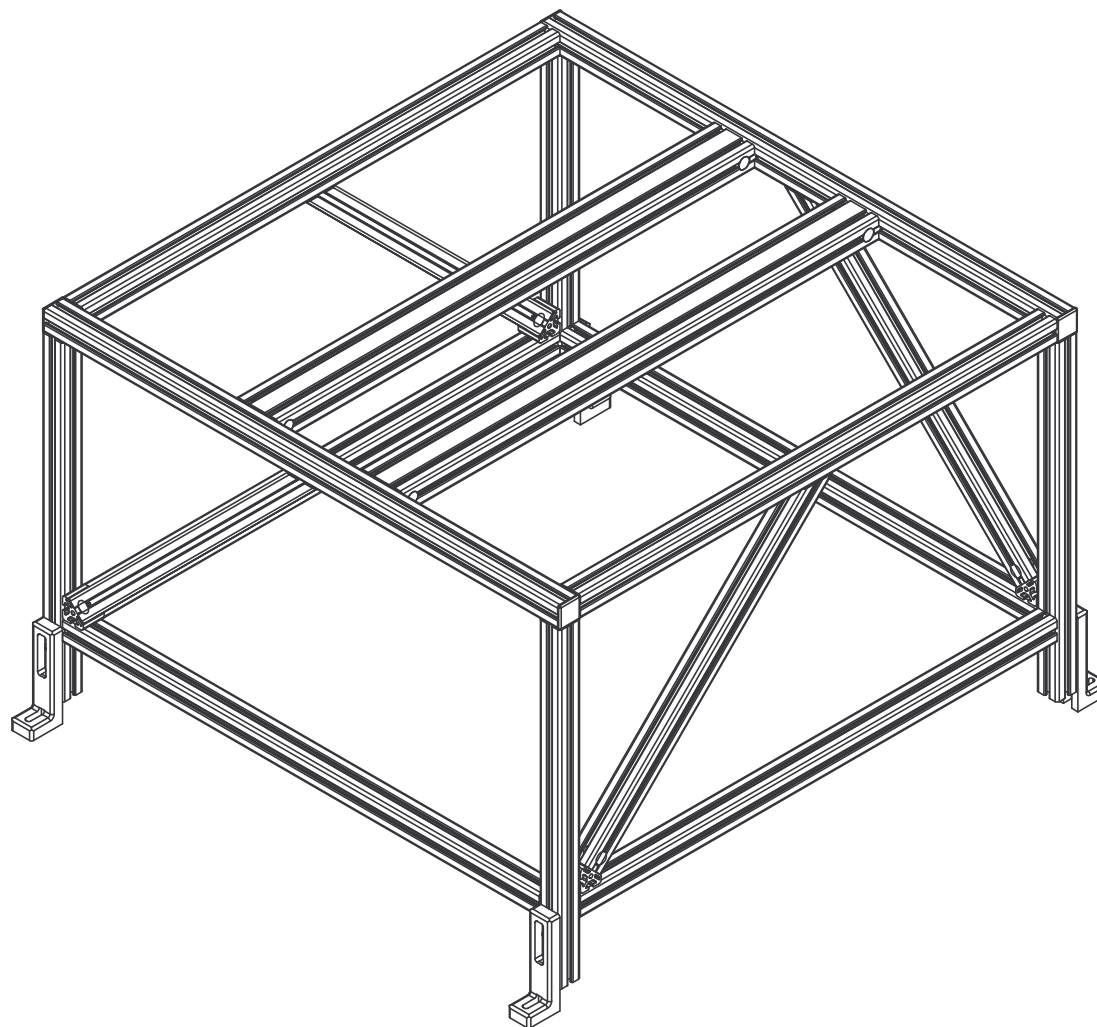
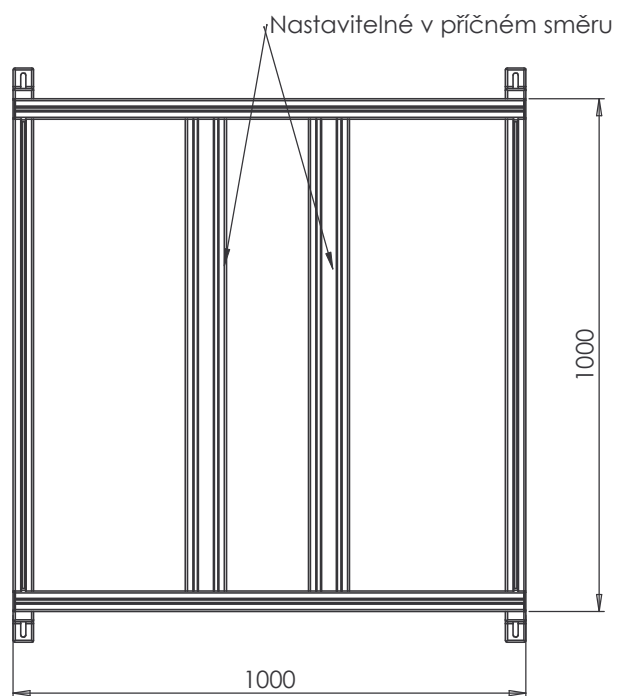
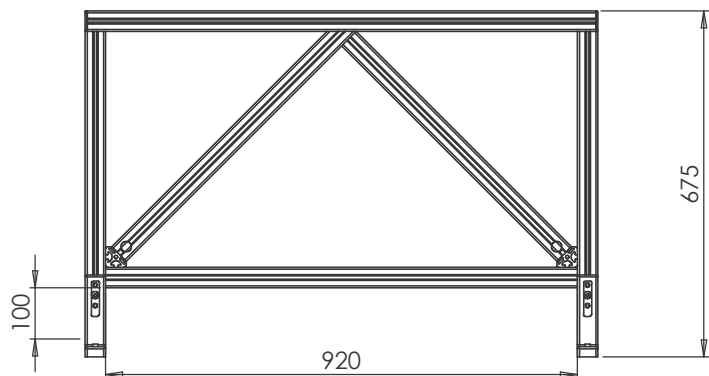

INFI-114-2010 Konstrukce pod robota - výkres

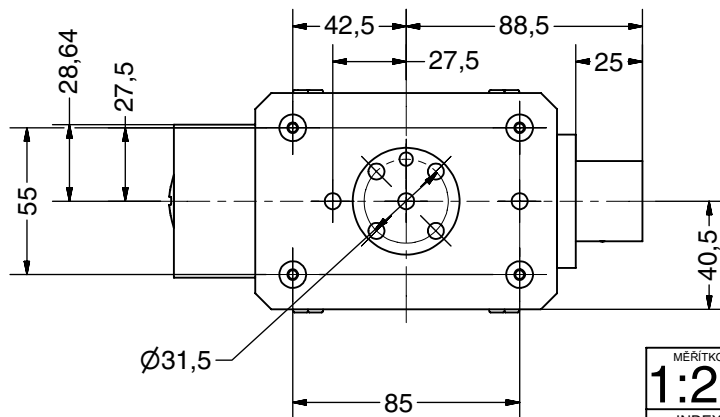
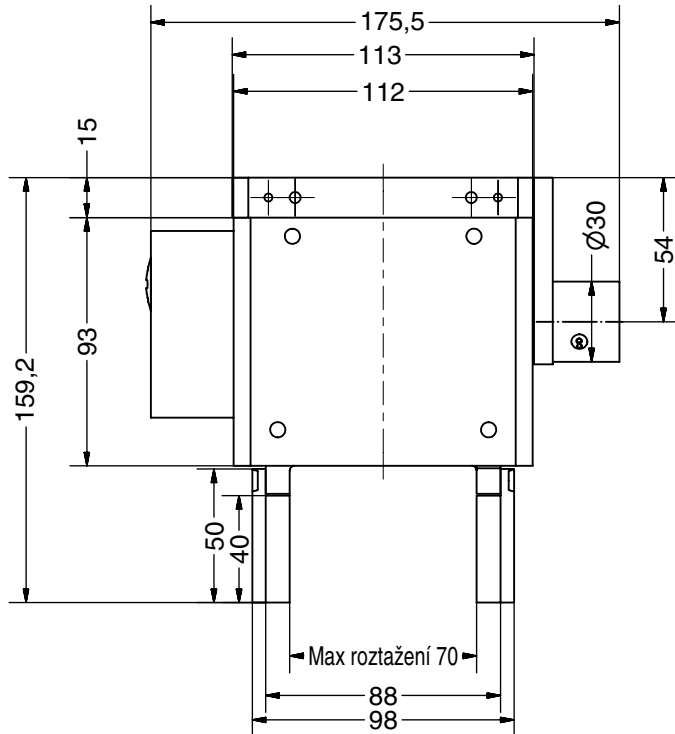
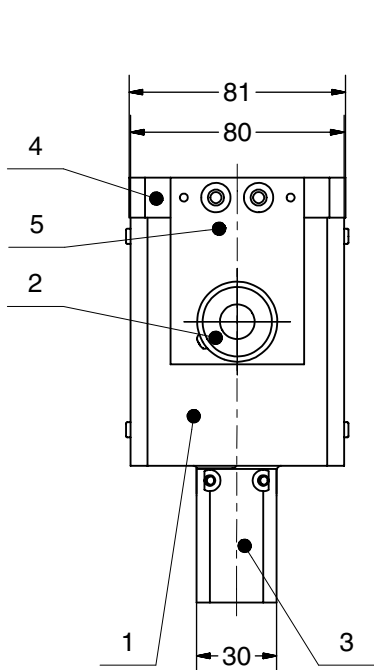

ISO (1:2)

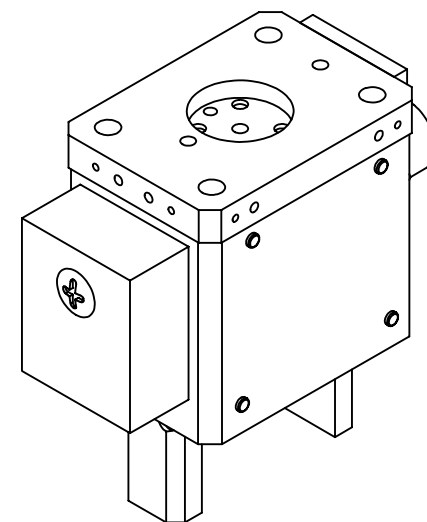

Kusovník			
POZ	KS	ČÍSLO VÝKRESU	NÁZEV VÝKRESU
1	1		SCHUNK-0306090
2	1		Magnet
3	2	10040_A_03	Upínka A1
4	1	10040_A_01	Příruba A1
5	1	10040_A_02	Deska A1

MĚŘÍTKO 1:2	MATERIAL PŮLOTOVAR	PŘESNOST ISO 2768 - mK	VYPRACOVAL JAHODA	NEOVISION Industrial Vision Systems
INDEX	ZMĚNY	PROMÍTÁNÍ	DATUM 26.8.2010	
1				SESTAVA CHAPADLA
2				
3				
4				
5				
6				
7				
TYP ROZMĚRY			NÁZEV	LIST 1
ČÍSLO VÝKRESU 10040-A-00				

A3