

Elements of Geometry for Computer Vision



Tomas Pajdla
pajdla@cvut.cz

Monday 17th February, 2020

Contents

1	Notation	1
2	Linear algebra	2
2.1	Change of coordinates induced by the change of basis	2
2.2	Determinant	5
2.2.1	Permutation	5
2.2.2	Determinant	6
2.3	Vector product	6
2.4	Dual space and dual basis	9
2.5	Operations with matrices	12
3	Affine space	15
3.1	Vectors	15
3.1.1	Geometric scalars	16
3.1.2	Geometric vectors	17
3.1.3	Bound vectors	17
3.2	Linear space	18
3.3	Free vectors	19
3.4	Affine space	21
3.5	Coordinate system in affine space	23
3.6	An example of affine space	24
3.6.1	Affine space of solutions of a system of linear equations	24
4	Motion	26
4.1	Change of position vector coordinates induced by motion	26
4.2	Rotation matrix	27
4.3	Coordinate vectors	31
5	Image coordinate system	32
6	Perspective camera	34
6.1	Perspective camera model	34
6.2	Computing image projection matrix from images of six points	38
7	Camera calibration	42
7.1	Camera pose	42
7.2	Camera calibration and angle between projection rays	50
7.3	Calibrated camera pose computation	51

8	Homography	60
8.1	Homography between images with the same center	60
8.2	Homography between images of a plane	64
8.2.1	Image of a plane	64
8.2.2	Two images of a plane	64
8.2.3	Homography between images of a plane by cameras with the same center	67
8.2.4	Homographies induced by a plane in the scene	68
8.3	Spherical image	72
8.4	Homography – summary	73
8.5	Constraint on the homographies of induced by two planes	75
8.6	Computing homography from image matches	76
8.6.1	General perspective cameras	76
8.6.2	Calibrated cameras	79
9	Projective plane	85
9.1	Motivation – perspective projection in affine space	85
9.2	Real projective plane	88
9.2.1	Geometrical model of the real projective plane	88
9.2.2	Algebraic model of the real projective plane	89
9.2.3	Lines of the real projective plane	90
9.2.4	Ideal line	92
9.2.5	Homogeneous coordinates	92
9.2.6	Incidence of points and lines	94
9.2.7	Join of points	95
9.2.8	Meet of lines	95
9.3	Line coordinates under homography	96
9.3.1	Join under homography	97
9.3.2	Meet under homography	97
9.3.3	Meet of join under homography	98
9.3.4	Note on homographies that are rotations	98
9.4	Vanishing points	98
9.5	Vanishing line and horizon	99
10	Projective space	101
10.1	Motivation – the union of ideal points of all affine planes	101
11	Camera auto-calibration	104
11.1	Constraints on ω	105
11.2	Camera calibration from angles between projection rays	107
11.3	Camera calibration from vanishing points	110
11.4	Camera calibration from images of squares	111
12	Two-view scene reconstruction	113
12.1	Epipolar geometry	113
12.2	Computing epipolar geometry from image matches	116
12.3	Ambiguity in two-view reconstruction	118

12.4	Reconstruction from two calibrated views	118
12.4.1	Camera computation	118
12.4.2	Point computation	121
12.5	Calibrated relative camera pose computation	121
12.5.1	Constraints on \mathbf{E}	121
12.5.2	Geometrical interpretation of Equation 12.77	123
12.5.3	Characterization of \mathbf{E}	124
12.5.4	Computing a non-zero multiple of \mathbf{E}	125
Index		131

1 Notation

\emptyset	...	the empty set [1]
$\exp U$...	the set of all subsets of set U [1]
$U \times V$...	Cartesian product of sets U and V [1]
\mathbb{Z}	...	whole numbers [1]
$\mathbb{Z}_{\geq 0}$...	non-negative integers [2]
(i.e. $0, 1, 2, \dots$) \mathbb{Q}	...	rational numbers [3]
\mathbb{R}	...	real numbers [3]
i	...	imaginary unit [3]
$(S, +, \cdot)$...	space of geometric scalars
A	...	affine space (space of geometric vectors)
(A_o, \oplus, \odot)	...	space of geometric vectors bound to point o
(V, \boxplus, \boxminus)	...	space of free vectors
\mathbb{A}^2	...	real affine plane
\mathbb{A}^3	...	three-dimensional real affine space
\mathbb{P}^2	...	real projective plane
\mathbb{P}^3	...	three-dimensional real projective space
\vec{x}	...	vector
A	...	matrix
A_{ij}	...	ij element of A
A^\top	...	transpose of A
A^\dagger	...	conjugate transpose of A
$ A $...	determinant of A
I	...	identity matrix
R	...	rotation matrix
\otimes	...	Kronecker product of matrices
$\beta = [\vec{b}_1, \vec{b}_2, \vec{b}_3]$...	basis (an ordered triple of independent generator vectors)
$\beta^*, \bar{\beta}$...	the dual basis to basis β
\vec{x}_β	...	column matrix of coordinates of \vec{x} w.r.t. the basis β
$\vec{x} \cdot \vec{y}$...	Euclidean scalar product of \vec{x} and \vec{y} ($\vec{x} \cdot \vec{y} = \vec{x}_\beta^\top \vec{y}_\beta$ in an orthonormal basis β)
$\vec{x} \times \vec{y}$...	cross (vector) product of \vec{x} and \vec{y}
$[\vec{x}]_\times$...	the matrix such that $[\vec{x}]_\times \vec{y} = \vec{x} \times \vec{y}$
$\ \vec{x}\ $...	Euclidean norm of \vec{x} ($\ \vec{x}\ = \sqrt{\vec{x} \cdot \vec{x}}$)
orthogonal vectors	...	mutually perpendicular and all of equal length
orthonormal vectors	...	unit orthogonal vectors
$P \circ l$...	point P is incident to line l
$P \vee Q$...	line(s) incident to points P and Q
$k \wedge l$...	point(s) incident to lines k and l

2 Linear algebra

We rely on linear algebra [4, 5, 6, 7, 8, 9]. We recommend excellent text books [7, 4] for acquiring basic as well as more advanced elements of the topic. Monograph [5] provides a number of examples and applications and provides a link to numerical and computational aspects of linear algebra. We will next review the most crucial topics needed in this text.

2.1 Change of coordinates induced by the change of basis

Let us discuss the relationship between the coordinates of a vector in a linear space, which is induced by passing from one basis to another. We shall derive the relationship between the coordinates in a three-dimensional linear space over real numbers, which is the most important when modeling the geometry around us. The formulas for all other n-dimensional spaces are obtained by passing from 3 to n.

§1 Coordinates Let us consider an ordered basis $\beta = [\vec{b}_1 \ \vec{b}_2 \ \vec{b}_3]$ of a three-dimensional vector space V^3 over scalars \mathbb{R} . A vector $\vec{v} \in V^3$ is uniquely expressed as a linear combination of basic vectors of V^3 by its *coordinates* $x, y, z \in \mathbb{R}$, i.e. $\vec{v} = x \vec{b}_1 + y \vec{b}_2 + z \vec{b}_3$, and can be represented as an ordered triple of coordinates, i.e. as $\vec{v}_\beta = [x \ y \ z]^\top$.

We see that an ordered triple of scalars can be understood as a triple of coordinates of a vector in V^3 w.r.t. a basis of V^3 . However, at the same time, the set of ordered triples $[x \ y \ z]^\top$ is also a three-dimensional *coordinate linear space* \mathbb{R}^3 over \mathbb{R} with $[x_1 \ y_1 \ z_1]^\top + [x_2 \ y_2 \ z_2]^\top = [x_1 + x_2 \ y_1 + y_2 \ z_1 + z_2]^\top$ and $s [x \ y \ z]^\top = [s x \ s y \ s z]^\top$ for $s \in \mathbb{R}$. Moreover, the ordered triple of the following three particular coordinate vectors

$$\sigma = \left[\begin{bmatrix} 1 \\ 0 \\ 0 \end{bmatrix} \quad \begin{bmatrix} 0 \\ 1 \\ 0 \end{bmatrix} \quad \begin{bmatrix} 0 \\ 0 \\ 1 \end{bmatrix} \right] \quad (2.1)$$

forms an ordered basis of \mathbb{R}^3 , the *standard basis*, and therefore a vector $\vec{v} = [x \ y \ z]^\top$ is represented by $\vec{v}_\sigma = [x \ y \ z]^\top$ w.r.t. the standard basis in \mathbb{R}^3 . It is noticeable that the vector \vec{v} and the coordinate vector \vec{v}_σ of its coordinates w.r.t. the standard basis of \mathbb{R}^3 , are identical.

§2 Two bases Having two ordered bases $\beta = [\vec{b}_1 \ \vec{b}_2 \ \vec{b}_3]$ and $\beta' = [\vec{b}'_1 \ \vec{b}'_2 \ \vec{b}'_3]$ leads to expressing one vector \vec{x} in two ways as $\vec{x} = x \vec{b}_1 + y \vec{b}_2 + z \vec{b}_3$ and $\vec{x} = x' \vec{b}'_1 + y' \vec{b}'_2 + z' \vec{b}'_3$. The vectors of the basis β can also be expressed in the basis β' using their coordinates. Let us introduce

$$\begin{aligned} \vec{b}_1 &= a_{11} \vec{b}'_1 + a_{21} \vec{b}'_2 + a_{31} \vec{b}'_3 \\ \vec{b}_2 &= a_{12} \vec{b}'_1 + a_{22} \vec{b}'_2 + a_{32} \vec{b}'_3 \\ \vec{b}_3 &= a_{13} \vec{b}'_1 + a_{23} \vec{b}'_2 + a_{33} \vec{b}'_3 \end{aligned} \quad (2.2)$$

§3 Change of coordinates We will next use the above equations to relate the coordinates of \vec{x} w.r.t. the basis β to the coordinates of \vec{x} w.r.t. the basis β'

$$\begin{aligned}\vec{x} &= x \vec{b}_1 + y \vec{b}_2 + z \vec{b}_3 \\ &= x (a_{11} \vec{b}'_1 + a_{21} \vec{b}'_2 + a_{31} \vec{b}'_3) + y (a_{12} \vec{b}'_1 + a_{22} \vec{b}'_2 + a_{32} \vec{b}'_3) + z (a_{13} \vec{b}'_1 + a_{23} \vec{b}'_2 + a_{33} \vec{b}'_3) \\ &= (a_{11} x + a_{12} y + a_{13} z) \vec{b}'_1 + (a_{21} x + a_{22} y + a_{23} z) \vec{b}'_2 + (a_{31} x + a_{32} y + a_{33} z) \vec{b}'_3 \\ &= x' \vec{b}'_1 + y' \vec{b}'_2 + z' \vec{b}'_3\end{aligned}\tag{2.3}$$

Since coordinates are unique, we get

$$x' = a_{11} x + a_{12} y + a_{13} z\tag{2.4}$$

$$y' = a_{21} x + a_{22} y + a_{23} z\tag{2.5}$$

$$z' = a_{31} x + a_{32} y + a_{33} z\tag{2.6}$$

Coordinate vectors \vec{x}_β and $\vec{x}_{\beta'}$ are thus related by the following matrix multiplication

$$\begin{bmatrix} x' \\ y' \\ z' \end{bmatrix} = \begin{bmatrix} a_{11} & a_{12} & a_{13} \\ a_{21} & a_{22} & a_{23} \\ a_{31} & a_{32} & a_{33} \end{bmatrix} \begin{bmatrix} x \\ y \\ z \end{bmatrix}\tag{2.7}$$

which we concisely write as

$$\vec{x}_{\beta'} = \mathbf{A} \vec{x}_\beta\tag{2.8}$$

The columns of matrix \mathbf{A} can be viewed as vectors of coordinates of basic vectors, $\vec{b}_1, \vec{b}_2, \vec{b}_3$ of β in the basis β'

$$\mathbf{A} = \begin{bmatrix} | & | & | \\ \vec{b}_{1_{\beta'}} & \vec{b}_{2_{\beta'}} & \vec{b}_{3_{\beta'}} \\ | & | & | \end{bmatrix}\tag{2.9}$$

and the matrix multiplication can be interpreted as a linear combination of the columns of \mathbf{A} by coordinates of \vec{x} w.r.t. β

$$\vec{x}_{\beta'} = x \vec{b}_{1_{\beta'}} + y \vec{b}_{2_{\beta'}} + z \vec{b}_{3_{\beta'}}\tag{2.10}$$

Matrix \mathbf{A} plays such an important role here that it deserves its own name. Matrix \mathbf{A} is very often called the *change of basis matrix from basis β to β'* or the *transition matrix from basis β to basis β'* [5, 10] since it can be used to pass from coordinates w.r.t. β to coordinates w.r.t. β' by Equation 2.8.

However, literature [6, 11] calls \mathbf{A} the *change of basis matrix from basis β' to β* , i.e. it (seemingly illogically) swaps the bases. This choice is motivated by the fact that \mathbf{A} relates vectors of β and vectors of β' by Equation 2.2 as

$$\begin{bmatrix} \vec{b}_1 & \vec{b}_2 & \vec{b}_3 \end{bmatrix} = \begin{bmatrix} a_{11} \vec{b}'_1 + a_{21} \vec{b}'_2 + a_{31} \vec{b}'_3 & a_{12} \vec{b}'_1 + a_{22} \vec{b}'_2 + a_{32} \vec{b}'_3 & a_{13} \vec{b}'_1 + a_{23} \vec{b}'_2 + a_{33} \vec{b}'_3 \end{bmatrix}\tag{2.11}$$

$$\begin{bmatrix} \vec{b}_1 & \vec{b}_2 & \vec{b}_3 \end{bmatrix} = \begin{bmatrix} \vec{b}'_1 & \vec{b}'_2 & \vec{b}'_3 \end{bmatrix} \begin{bmatrix} a_{11} & a_{12} & a_{13} \\ a_{21} & a_{22} & a_{23} \\ a_{31} & a_{32} & a_{33} \end{bmatrix}\tag{2.12}$$

and therefore giving

$$\begin{bmatrix} \vec{b}_1 & \vec{b}_2 & \vec{b}_3 \end{bmatrix} = \begin{bmatrix} \vec{b}'_1 & \vec{b}'_2 & \vec{b}'_3 \end{bmatrix} \mathbf{A} \quad (2.13)$$

or equivalently

$$\begin{bmatrix} \vec{b}'_1 & \vec{b}'_2 & \vec{b}'_3 \end{bmatrix} = \begin{bmatrix} \vec{b}_1 & \vec{b}_2 & \vec{b}_3 \end{bmatrix} \mathbf{A}^{-1} \quad (2.14)$$

where the multiplication of a row of column vectors by a matrix from the right in Equation 2.13 has the meaning given by Equation 2.11 above. Yet another variation of the naming appeared in [8, 9] where \mathbf{A}^{-1} was named the *change of basis matrix from basis β to β'* .

We have to conclude that the meaning associated with the *change of basis matrix* varies in the literature and hence we will avoid this confusing name and talk about \mathbf{A} as about the *matrix transforming coordinates of a vector from basis β to basis β'* .

There is the following interesting variation of Equation 2.13

$$\begin{bmatrix} \vec{b}'_1 \\ \vec{b}'_2 \\ \vec{b}'_3 \end{bmatrix} = \mathbf{A}^{-\top} \begin{bmatrix} \vec{b}_1 \\ \vec{b}_2 \\ \vec{b}_3 \end{bmatrix} \quad (2.15)$$

where the basic vectors of β and β' are understood as elements of column vectors. For instance, vector \vec{b}'_1 is obtained as

$$\vec{b}'_1 = a_{11}^* \vec{b}_1 + a_{12}^* \vec{b}_2 + a_{13}^* \vec{b}_3 \quad (2.16)$$

where $[a_{11}^*, a_{12}^*, a_{13}^*]$ is the first row of $\mathbf{A}^{-\top}$.

§4 Example We demonstrate the relationship between vectors and bases on a concrete example. Consider two bases α and β represented by coordinate vectors, which we write into matrices

$$\alpha = \begin{bmatrix} \vec{a}_1 & \vec{a}_2 & \vec{a}_3 \end{bmatrix} = \begin{bmatrix} 1 & 1 & 0 \\ 0 & 1 & 1 \\ 0 & 0 & 1 \end{bmatrix} \quad (2.17)$$

$$\beta = \begin{bmatrix} \vec{b}_1 & \vec{b}_2 & \vec{b}_3 \end{bmatrix} = \begin{bmatrix} 1 & 1 & 1 \\ 0 & 0 & 1 \\ 0 & 1 & 1 \end{bmatrix}, \quad (2.18)$$

and a vector \vec{x} with coordinates w.r.t. the basis α

$$\vec{x}_\alpha = \begin{bmatrix} 1 \\ 1 \\ 1 \end{bmatrix} \quad (2.19)$$

We see that basic vectors of α can be obtained as the following linear combinations of basic vectors of β

$$\vec{a}_1 = +1 \vec{b}_1 + 0 \vec{b}_2 + 0 \vec{b}_3 \quad (2.20)$$

$$\vec{a}_2 = +1 \vec{b}_1 - 1 \vec{b}_2 + 1 \vec{b}_3 \quad (2.21)$$

$$\vec{a}_3 = -1 \vec{b}_1 + 0 \vec{b}_2 + 1 \vec{b}_3 \quad (2.22)$$

or equivalently

$$[\vec{a}_1 \ \vec{a}_2 \ \vec{a}_3] = [\vec{b}_1 \ \vec{b}_2 \ \vec{b}_3] \begin{bmatrix} 1 & 1 & -1 \\ 0 & -1 & 0 \\ 0 & 1 & 1 \end{bmatrix} = [\vec{b}_1 \ \vec{b}_2 \ \vec{b}_3] \mathbf{A} \quad (2.23)$$

Coordinates of \vec{x} w.r.t. β are hence obtained as

$$\vec{x}_\beta = \mathbf{A} \vec{x}_\alpha, \quad \mathbf{A} = \begin{bmatrix} 1 & 1 & -1 \\ 0 & -1 & 0 \\ 0 & 1 & 1 \end{bmatrix} \quad (2.24)$$

$$\begin{bmatrix} 1 \\ -1 \\ 2 \end{bmatrix} = \begin{bmatrix} 1 & 1 & -1 \\ 0 & -1 & 0 \\ 0 & 1 & 1 \end{bmatrix} \begin{bmatrix} 1 \\ 1 \\ 1 \end{bmatrix} \quad (2.25)$$

We see that

$$\alpha = \beta \mathbf{A} \quad (2.26)$$

$$\begin{bmatrix} 1 & 1 & 0 \\ 0 & 1 & 1 \\ 0 & 0 & 1 \end{bmatrix} = \begin{bmatrix} 1 & 1 & 1 \\ 0 & 0 & 1 \\ 0 & 1 & 1 \end{bmatrix} \begin{bmatrix} 1 & 1 & -1 \\ 0 & -1 & 0 \\ 0 & 1 & 1 \end{bmatrix} \quad (2.27)$$

The following questions arises: When are the coordinates of a vector \vec{x} (Equation 2.8) and the basic vectors themselves (Equation 2.15) transformed in the same way? In other words, when $\mathbf{A} = \mathbf{A}^{-\top}$. We shall give the answer to this question later in paragraph 2.4.

2.2 Determinant

Determinant [4] of a matrix \mathbf{A} , denoted by $|\mathbf{A}|$, is a very interesting and useful concept. It can be, for instance, used to check the linear independence of a set of vectors or to define an orientation of the space.

2.2.1 Permutation

A *permutation* [4] π on the set $[n] = \{1, \dots, n\}$ of integers is a one-to-one function from $[n]$ onto $[n]$. The identity permutation will be denoted by ϵ , i.e. $\epsilon(i) = i$ for all $i \in [n]$.

§1 Composition of permutations Let σ and π be two permutations on $[n]$. Then, their composition, i.e. $\pi(\sigma)$, is also a permutation on $[n]$ since a composition of two one-to-one onto functions is a one-to-one onto function.

§2 Sign of a permutation We will now introduce another important concept related to permutations. *Sign*, $\text{sgn}(\pi)$, of a permutation π is defined as

$$\text{sgn}(\pi) = (-1)^{N(\pi)} \quad (2.28)$$

where $N(\pi)$ is equal to the number of *inversions* in π , i.e. the number of pairs $[i, j]$ such that $i, j \in [n]$, $i < j$ and $\pi(i) > \pi(j)$.

2.2.2 Determinant

Let S_n be the set of all permutations on $[n]$ and \mathbf{A} be an $n \times n$ matrix. Then, *determinant* $|\mathbf{A}|$ of \mathbf{A} is defined by the formula

$$|\mathbf{A}| = \sum_{\pi \in S_n} \text{sgn}(\pi) \mathbf{A}_{1,\pi(1)} \mathbf{A}_{2,\pi(2)} \cdots \mathbf{A}_{n,\pi(n)} \quad (2.29)$$

Notice that for every $\pi \in S_n$ and for $j \in [n]$ there is exactly one $i \in [n]$ such that $j = \pi(i)$. Hence

$$\{[1, \pi(1)], [2, \pi(2)], \dots, [n, \pi(n)]\} = \{[\pi^{-1}(1), 1], [\pi^{-1}(2), 2], \dots, [\pi^{-1}(n), n]\} \quad (2.30)$$

and since the multiplication of elements of \mathbf{A} is commutative we get

$$|\mathbf{A}| = \sum_{\pi \in S_n} \text{sgn}(\pi) \mathbf{A}_{\pi^{-1}(1),1} \mathbf{A}_{\pi^{-1}(2),2} \cdots \mathbf{A}_{\pi^{-1}(n),n} \quad (2.31)$$

Let us next define a submatrix of \mathbf{A} and find its determinant. Consider $k \leq n$ and two one-to-one *monotonic* functions $\rho, \nu: [k] \rightarrow [n]$, $i < j \Rightarrow \rho(i) < \rho(j)$, $\nu(i) < \nu(j)$. We define $k \times k$ submatrix $\mathbf{A}^{\rho,\nu}$ of an $n \times n$ matrix \mathbf{A} by

$$\mathbf{A}_{i,j}^{\rho,\nu} = \mathbf{A}_{\rho(i),\nu(j)} \quad \text{for } i, j \in [k] \quad (2.32)$$

We get the determinant of $\mathbf{A}^{\rho,\nu}$ as follows

$$|\mathbf{A}^{\rho,\nu}| = \sum_{\pi \in S_k} \text{sgn}(\pi) \mathbf{A}_{1,\pi(1)}^{\rho,\nu} \mathbf{A}_{2,\pi(2)}^{\rho,\nu} \cdots \mathbf{A}_{k,\pi(k)}^{\rho,\nu} \quad (2.33)$$

$$= \sum_{\pi \in S_k} \text{sgn}(\pi) \mathbf{A}_{\rho(1),\nu(\pi(1))} \mathbf{A}_{\rho(2),\nu(\pi(2))} \cdots \mathbf{A}_{\rho(k),\nu(\pi(k))} \quad (2.34)$$

Let us next split the rows of the matrix \mathbf{A} into two groups of k and m rows and find the relationship between $|\mathbf{A}|$ and the determinants of certain $k \times k$ and $m \times m$ submatrices of \mathbf{A} . Take $1 \leq k, m \leq n$ such that $k + m = n$ and define a one-to-one function $\rho: [m] \rightarrow [k + 1, n] = \{k + 1, \dots, n\}$, by $\rho(i) = k + i$. Next, let $\Omega \subseteq \exp[n]$ be the set of all subsets of $[n]$ of size k . Let $\omega \in \Omega$. Then, there is exactly one one-to-one monotonic function φ_ω from $[k]$ onto ω since $[k]$ and ω are finite sets of integers of the same size. Let $\bar{\omega} = [n] \setminus \omega$. Then, there is exactly one one-to-one monotonic function $\varphi_{\bar{\omega}}$ from $[k + 1, n]$ onto $\bar{\omega}$. Let further there be $\pi_k \in S_k$ and $\pi_m \in S_m$. With the notation introduced above, we are getting a version of the generalized Laplace expansion of the determinant [12, 13]

$$|\mathbf{A}| = \sum_{\omega \in \Omega} \left(\prod_{i \in [k], j \in [k+1, n]} \text{sgn}(\varphi_{\bar{\omega}}(j) - \varphi_\omega(i)) \right) |\mathbf{A}^{\epsilon, \varphi_\omega}| |\mathbf{A}^{\rho, \varphi_{\bar{\omega}}(\rho)}| \quad (2.35)$$

2.3 Vector product

Let us look at an interesting mapping from $\mathbb{R}^3 \times \mathbb{R}^3$ to \mathbb{R}^3 , the *vector product* in \mathbb{R}^3 [7] (which it also often called the cross product [5]). Vector product has interesting geometrical properties but we shall motivate it by its connection to systems of linear equations.

§ 1 Vector product Assume two linearly independent coordinate vectors $\vec{x} = [x_1 \ x_2 \ x_3]^\top$ and $\vec{y} = [y_1 \ y_2 \ y_3]^\top$ in \mathbb{R}^3 . The following system of linear equations

$$\begin{bmatrix} x_1 & x_2 & x_3 \\ y_1 & y_2 & y_3 \end{bmatrix} \vec{z} = 0 \quad (2.36)$$

has a one-dimensional subspace V of solutions in \mathbb{R}^3 . The solutions can be written as multiples of one non-zero vector \vec{w} , the basis of V , i.e.

$$\vec{z} = \lambda \vec{w}, \quad \lambda \in \mathbb{R} \quad (2.37)$$

Let us see how we can construct \vec{w} in a convenient way from vectors \vec{x}, \vec{y} .

Consider determinants of two matrices constructed from the matrix of the system (2.36) by adjoining its first, resp. second, row to the matrix of the system (2.36)

$$\left| \begin{bmatrix} x_1 & x_2 & x_3 \\ y_1 & y_2 & y_3 \\ x_1 & x_2 & x_3 \end{bmatrix} \right| = 0 \quad \left| \begin{bmatrix} x_1 & x_2 & x_3 \\ y_1 & y_2 & y_3 \\ y_1 & y_2 & y_3 \end{bmatrix} \right| = 0 \quad (2.38)$$

which gives

$$x_1(x_2 y_3 - x_3 y_2) + x_2(x_3 y_1 - x_1 y_3) + x_3(x_1 y_2 - x_2 y_1) = 0 \quad (2.39)$$

$$y_1(x_2 y_3 - x_3 y_2) + y_2(x_3 y_1 - x_1 y_3) + y_3(x_1 y_2 - x_2 y_1) = 0 \quad (2.40)$$

and can be rewritten as

$$\begin{bmatrix} x_1 & x_2 & x_3 \\ y_1 & y_2 & y_3 \end{bmatrix} \begin{bmatrix} x_2 y_3 - x_3 y_2 \\ -x_1 y_3 + x_3 y_1 \\ x_1 y_2 - x_2 y_1 \end{bmatrix} = 0 \quad (2.41)$$

We see that vector

$$\vec{w} = \begin{bmatrix} x_2 y_3 - x_3 y_2 \\ -x_1 y_3 + x_3 y_1 \\ x_1 y_2 - x_2 y_1 \end{bmatrix} \quad (2.42)$$

solves Equation 2.36.

Notice that elements of \vec{w} are the three two by two minors of the matrix of the system (2.36). The rank of the matrix is two, which means that at least one of the minors is non-zero, and hence \vec{w} is also non-zero. We see that \vec{w} is a basic vector of V . Formula 2.42 is known as the *vector product* in \mathbb{R}^3 and \vec{w} is also often denoted by $\vec{x} \times \vec{y}$.

§ 2 Vector product under the change of basis Let us next study the behavior of the vector product under the change of basis in \mathbb{R}^3 . Let us have two bases β, β' in \mathbb{R}^3 and two vectors \vec{x}, \vec{y} with coordinates $\vec{x}_\beta = [x_1 \ x_2 \ x_3]^\top$, $\vec{y}_\beta = [y_1 \ y_2 \ y_3]^\top$ and $\vec{x}_{\beta'} = [x'_1 \ x'_2 \ x'_3]^\top$, $\vec{y}_{\beta'} = [y'_1 \ y'_2 \ y'_3]^\top$. We introduce

$$\vec{x}_\beta \times \vec{y}_\beta = \begin{bmatrix} x_2 y_3 - x_3 y_2 \\ -x_1 y_3 + x_3 y_1 \\ x_1 y_2 - x_2 y_1 \end{bmatrix} \quad \vec{x}_{\beta'} \times \vec{y}_{\beta'} = \begin{bmatrix} x'_2 y'_3 - x'_3 y'_2 \\ -x'_1 y'_3 + x'_3 y'_1 \\ x'_1 y'_2 - x'_2 y'_1 \end{bmatrix} \quad (2.43)$$

To find the relationship between $\vec{x}_\beta \times \vec{y}_\beta$ and $\vec{x}_{\beta'} \times \vec{y}_{\beta'}$, we will use the following fact. For every three vectors $\vec{x} = [x_1 \ x_2 \ x_3]^\top$, $\vec{y} = [y_1 \ y_2 \ y_3]^\top$, $\vec{z} = [z_1 \ z_2 \ z_3]^\top$ in \mathbb{R}^3 there holds

$$\vec{z}^\top (\vec{x} \times \vec{y}) = [z_1 \ z_2 \ z_3] \begin{bmatrix} x_2 y_3 - x_3 y_2 \\ -x_1 y_3 + x_3 y_1 \\ x_1 y_2 - x_2 y_1 \end{bmatrix} = \begin{vmatrix} x_1 & x_2 & x_3 \\ y_1 & y_2 & y_3 \\ z_1 & z_2 & z_3 \end{vmatrix} = \begin{vmatrix} \vec{x}^\top \\ \vec{y}^\top \\ \vec{z}^\top \end{vmatrix} \quad (2.44)$$

We can write

$$\begin{aligned} \vec{x}_{\beta'} \times \vec{y}_{\beta'} &= \begin{bmatrix} [1 \ 0 \ 0] (\vec{x}_{\beta'} \times \vec{y}_{\beta'}) \\ [0 \ 1 \ 0] (\vec{x}_{\beta'} \times \vec{y}_{\beta'}) \\ [0 \ 0 \ 1] (\vec{x}_{\beta'} \times \vec{y}_{\beta'}) \end{bmatrix} = \begin{bmatrix} \left\| \begin{bmatrix} \vec{x}_{\beta'}^\top \\ \vec{y}_{\beta'}^\top \\ 1 \ 0 \ 0 \end{bmatrix} \right\| & \left\| \begin{bmatrix} \vec{x}_{\beta'}^\top \\ \vec{y}_{\beta'}^\top \\ 0 \ 1 \ 0 \end{bmatrix} \right\| & \left\| \begin{bmatrix} \vec{x}_{\beta'}^\top \\ \vec{y}_{\beta'}^\top \\ 0 \ 0 \ 1 \end{bmatrix} \right\| \end{bmatrix}^\top \\ &= \begin{bmatrix} \left\| \begin{bmatrix} \vec{x}_\beta^\top \mathbf{A}^\top \\ \vec{y}_\beta^\top \mathbf{A}^\top \\ 1 \ 0 \ 0 \end{bmatrix} \right\| & \left\| \begin{bmatrix} \vec{x}_\beta^\top \mathbf{A}^\top \\ \vec{y}_\beta^\top \mathbf{A}^\top \\ 0 \ 1 \ 0 \end{bmatrix} \right\| & \left\| \begin{bmatrix} \vec{x}_\beta^\top \mathbf{A}^\top \\ \vec{y}_\beta^\top \mathbf{A}^\top \\ 0 \ 0 \ 1 \end{bmatrix} \right\| \end{bmatrix}^\top \\ &= \begin{bmatrix} \left\| \begin{bmatrix} \vec{x}_\beta^\top \\ \vec{y}_\beta^\top \\ [1 \ 0 \ 0] \mathbf{A}^{-\top} \end{bmatrix} \mathbf{A}^\top \right\| & \left\| \begin{bmatrix} \vec{x}_\beta^\top \\ \vec{y}_\beta^\top \\ [0 \ 1 \ 0] \mathbf{A}^{-\top} \end{bmatrix} \mathbf{A}^\top \right\| & \left\| \begin{bmatrix} \vec{x}_\beta^\top \\ \vec{y}_\beta^\top \\ [0 \ 0 \ 1] \mathbf{A}^{-\top} \end{bmatrix} \mathbf{A}^\top \right\| \end{bmatrix}^\top \\ &= \begin{bmatrix} [1 \ 0 \ 0] \mathbf{A}^{-\top} (\vec{x}_\beta \times \vec{y}_\beta) \\ [0 \ 1 \ 0] \mathbf{A}^{-\top} (\vec{x}_\beta \times \vec{y}_\beta) \\ [0 \ 0 \ 1] \mathbf{A}^{-\top} (\vec{x}_\beta \times \vec{y}_\beta) \end{bmatrix} |\mathbf{A}^\top| \\ &= \frac{\mathbf{A}^{-\top}}{|\mathbf{A}^{-\top}|} (\vec{x}_\beta \times \vec{y}_\beta) \end{aligned} \quad (2.45)$$

§3 Vector product as a linear mapping It is interesting to see that for all $\vec{x}, \vec{y} \in \mathbb{R}^3$ there holds

$$\vec{x} \times \vec{y} = \begin{bmatrix} x_2 y_3 - x_3 y_2 \\ -x_1 y_3 + x_3 y_1 \\ x_1 y_2 - x_2 y_1 \end{bmatrix} = \begin{bmatrix} 0 & -x_3 & x_2 \\ x_3 & 0 & -x_1 \\ -x_2 & x_1 & 0 \end{bmatrix} \begin{bmatrix} y_1 \\ y_2 \\ y_3 \end{bmatrix} \quad (2.46)$$

and thus we can introduce matrix

$$[\vec{x}]_\times = \begin{bmatrix} 0 & -x_3 & x_2 \\ x_3 & 0 & -x_1 \\ -x_2 & x_1 & 0 \end{bmatrix} \quad (2.47)$$

and write

$$\vec{x} \times \vec{y} = [\vec{x}]_\times \vec{y} \quad (2.48)$$

Notice also that $[\vec{x}]_\times^\top = -[\vec{x}]_\times$ and therefore

$$(\vec{x} \times \vec{y})^\top = ([\vec{x}]_\times \vec{y})^\top = -\vec{y}^\top [\vec{x}]_\times \quad (2.49)$$

The result of §2 can also be written in the formalism of this paragraph. We can write for every $\vec{x}, \vec{y} \in \mathbb{R}^3$

$$[\mathbf{A} \vec{x}_\beta]_\times \mathbf{A} \vec{y}_\beta = (\mathbf{A} \vec{x}_\beta) \times (\mathbf{A} \vec{y}_\beta) = \frac{\mathbf{A}^{-\top}}{|\mathbf{A}^{-\top}|} (\vec{x}_\beta \times \vec{y}_\beta) = \frac{\mathbf{A}^{-\top}}{|\mathbf{A}^{-\top}|} [\vec{x}_\beta]_\times \vec{y}_\beta \quad (2.50)$$

and hence we get for every $\vec{x} \in \mathbb{R}^3$

$$[\mathbf{A} \vec{x}_\beta]_\times \mathbf{A} = \frac{\mathbf{A}^{-\top}}{|\mathbf{A}^{-\top}|} [\vec{x}_\beta]_\times \quad (2.51)$$

2.4 Dual space and dual basis

Let us start with a three-dimensional linear space L over scalars S and consider the set L^\star of all linear functions $f: L \rightarrow S$, i.e. the functions on L for which the following holds true

$$f(a\vec{x} + b\vec{y}) = a f(\vec{x}) + b f(\vec{y}) \quad (2.52)$$

for all $a, b \in S$ and all $\vec{x}, \vec{y} \in L$.

Let us next define the addition $+^\star: L^\star \times L^\star \rightarrow L^\star$ of linear functions $f, g \in L^\star$ and the multiplication $\cdot^\star: S \times L^\star \rightarrow L^\star$ of a linear function $f \in L^\star$ by a scalar $a \in S$ such that

$$(f +^\star g)(\vec{x}) = f(\vec{x}) + g(\vec{x}) \quad (2.53)$$

$$(a \cdot^\star f)(\vec{x}) = a f(\vec{x}) \quad (2.54)$$

holds true for all $a \in S$ and for all $\vec{x} \in L$. One can verify that $(L^\star, +^\star, \cdot^\star)$ over $(S, +, \cdot)$ is itself a linear space [4, 7, 6]. It makes therefore a good sense to use arrows above symbols for linear functions, e.g. \vec{f} instead of f .

The linear space L^\star is derived from, and naturally connected to, the linear space L and hence deserves a special name. Linear space L^\star is called [4] the *dual (linear) space* to L .

Now, consider a basis $\beta = [\vec{b}_1, \vec{b}_2, \vec{b}_3]$ of L . We will construct a basis β^\star of L^\star , in a certain natural and useful way. Let us take three linear functions $\vec{b}_1^\star, \vec{b}_2^\star, \vec{b}_3^\star \in L^\star$ such that

$$\begin{aligned} \vec{b}_1^\star(\vec{b}_1) &= 1 & \vec{b}_1^\star(\vec{b}_2) &= 0 & \vec{b}_1^\star(\vec{b}_3) &= 0 \\ \vec{b}_2^\star(\vec{b}_1) &= 0 & \vec{b}_2^\star(\vec{b}_2) &= 1 & \vec{b}_2^\star(\vec{b}_3) &= 0 \\ \vec{b}_3^\star(\vec{b}_1) &= 0 & \vec{b}_3^\star(\vec{b}_2) &= 0 & \vec{b}_3^\star(\vec{b}_3) &= 1 \end{aligned} \quad (2.55)$$

where 0 and 1 are the zero and the unit element of S , respectively. First of all, one has to verify [4] that such an assignment is possible with linear functions over L . Secondly one can show [4] that functions $\vec{b}_1^\star, \vec{b}_2^\star, \vec{b}_3^\star$ are determined by this assignment uniquely on all vectors of L . Finally, one can observe [4] that the triple $\beta^\star = [\vec{b}_1^\star, \vec{b}_2^\star, \vec{b}_3^\star]$ forms an (ordered) basis of L^\star . The basis β^\star is called the *dual basis* of L^\star , i.e. it is the basis of L^\star , which is related in a special (dual) way to the basis β of L .

§1 Evaluating linear functions Consider a vector $\vec{x} \in L$ with coordinates $\vec{x}_\beta = [x_1, x_2, x_3]^\top$ w.r.t. a basis $\beta = [\vec{b}_1, \vec{b}_2, \vec{b}_3]$ and a linear function $\vec{h} \in L^\star$ with coordinates $\vec{h}_{\beta^\star} = [h_1, h_2, h_3]^\top$ w.r.t. the dual basis $\beta^\star = [\vec{b}_1^\star, \vec{b}_2^\star, \vec{b}_3^\star]$. The value $\vec{h}(\vec{x}) \in S$ is obtained from the coordinates \vec{x}_β

and \vec{h}_{β^*} as

$$\vec{h}(\vec{x}) = \vec{h}(x_1 \vec{b}_1 + x_2 \vec{b}_2 + x_3 \vec{b}_3) \quad (2.56)$$

$$= (h_1 \vec{b}_1^* + h_2 \vec{b}_2^* + h_3 \vec{b}_3^*)(x_1 \vec{b}_1 + x_2 \vec{b}_2 + x_3 \vec{b}_3) \quad (2.57)$$

$$\begin{aligned} &= h_1 \vec{b}_1^*(\vec{b}_1) x_1 + h_1 \vec{b}_1^*(\vec{b}_2) x_2 + h_1 \vec{b}_1^*(\vec{b}_3) x_3 \\ &\quad + h_2 \vec{b}_2^*(\vec{b}_1) x_1 + h_2 \vec{b}_2^*(\vec{b}_2) x_2 + h_2 \vec{b}_2^*(\vec{b}_3) x_3 \\ &\quad + h_3 \vec{b}_3^*(\vec{b}_1) x_1 + h_3 \vec{b}_3^*(\vec{b}_2) x_2 + h_3 \vec{b}_3^*(\vec{b}_3) x_3 \end{aligned} \quad (2.58)$$

$$= [h_1 \quad h_2 \quad h_3] \begin{bmatrix} \vec{b}_1^*(\vec{b}_1) & \vec{b}_1^*(\vec{b}_2) & \vec{b}_1^*(\vec{b}_3) \\ \vec{b}_2^*(\vec{b}_1) & \vec{b}_2^*(\vec{b}_2) & \vec{b}_2^*(\vec{b}_3) \\ \vec{b}_3^*(\vec{b}_1) & \vec{b}_3^*(\vec{b}_2) & \vec{b}_3^*(\vec{b}_3) \end{bmatrix} \begin{bmatrix} x_1 \\ x_2 \\ x_3 \end{bmatrix} \quad (2.59)$$

$$= [h_1 \quad h_2 \quad h_3] \begin{bmatrix} 1 & 0 & 0 \\ 0 & 1 & 0 \\ 0 & 0 & 1 \end{bmatrix} \begin{bmatrix} x_1 \\ x_2 \\ x_3 \end{bmatrix} \quad (2.60)$$

$$= [h_1, h_2, h_3] \begin{bmatrix} x_1 \\ x_2 \\ x_3 \end{bmatrix} \quad (2.61)$$

$$= \vec{h}_{\beta^*}^\top \vec{x}_\beta \quad (2.62)$$

The value of $\vec{h} \in L^*$ on $\vec{x} \in L$ is obtained by multiplying \vec{x}_β by the transpose of \vec{h}_{β^*} from the left.

Notice that the middle matrix on the right in Equation 2.59 evaluates into the identity. This is the consequence of using the pair of a basis and its dual basis. The formula 2.62 can be generalized to the situation when bases are not dual by evaluating the middle matrix accordingly. In general

$$\vec{h}(\vec{x}) = \vec{h}_{\bar{\beta}}^\top [\vec{b}_i(\vec{b}_j)] \vec{x}_\beta \quad (2.63)$$

where matrix $[\vec{b}_i(\vec{b}_j)]$ is constructed from the respective bases $\beta, \bar{\beta}$ of L and L^* .

§2 Changing the basis in a linear space and in its dual Let us now look at what happens with coordinates of vectors of L^* when passing from the dual basis β^* to the dual basis β'^* induced by passing from a basis β to a basis β' in L . Consider vector $\vec{x} \in L$ and a linear function $\vec{h} \in L^*$ and their coordinates $\vec{x}_\beta, \vec{x}_{\beta'}$ and $\vec{h}_{\beta^*}, \vec{h}_{\beta'^*}$ w.r.t. the respective bases. Introduce further matrix \mathbf{A} transforming coordinates of vectors in L as

$$\vec{x}_{\beta'} = \mathbf{A} \vec{x}_\beta \quad (2.64)$$

when passing from β to β' .

Basis β^* is the dual basis to β and basis β'^* is the dual basis to β' and therefore

$$\vec{h}_{\beta^*}^\top \vec{x}_\beta = \vec{h}(\vec{x}) = \vec{h}_{\beta'^*}^\top \vec{x}_{\beta'} \quad (2.65)$$

for all $\vec{x} \in L$ and all $\vec{h} \in L^*$. Hence

$$\vec{h}_{\beta^*}^\top \vec{x}_\beta = \vec{h}_{\beta'^*}^\top \mathbf{A} \vec{x}_\beta \quad (2.66)$$

for all $\vec{x} \in L$ and therefore

$$\vec{h}_{\beta^*}^\top = \vec{h}_{\beta'^*}^\top \mathbf{A} \quad (2.67)$$

or equivalently

$$\vec{h}_{\beta^*} = \mathbf{A}^\top \vec{h}_{\beta'^*} \quad (2.68)$$

Let us now see what is the meaning of the rows of matrix \mathbf{A} . It becomes clear from Equation 2.67 that the columns of matrix \mathbf{A}^\top can be viewed as vectors of coordinates of basic vectors of $\beta'^* = [\vec{b}'_{1^*}, \vec{b}'_{2^*}, \vec{b}'_{3^*}]$ in the basis $\beta^* = [\vec{b}_1^*, \vec{b}_2^*, \vec{b}_3^*]$ and therefore

$$\mathbf{A} = \begin{bmatrix} \text{---} \vec{b}'_{1^*}{}^\top \text{---} \\ \text{---} \vec{b}'_{2^*}{}^\top \text{---} \\ \text{---} \vec{b}'_{3^*}{}^\top \text{---} \end{bmatrix} \quad (2.69)$$

which means that the rows of \mathbf{A} are coordinates of the dual basis of the primed dual space in the dual basis of the non-primed dual space.

Finally notice that we can also write

$$\vec{h}_{\beta'^*} = \mathbf{A}^{-\top} \vec{h}_{\beta^*} \quad (2.70)$$

which is formally identical with Equation 2.15.

§3 When do coordinates transform the same way in a basis and in its dual basis It is natural to ask when it happens that the coordinates of linear functions in L^* w.r.t. the dual basis β^* transform the same way as the coordinates of vectors of L w.r.t. the original basis β , i.e.

$$\vec{x}_{\beta'} = \mathbf{A} \vec{x}_\beta \quad (2.71)$$

$$\vec{h}_{\beta'^*} = \mathbf{A} \vec{h}_{\beta^*} \quad (2.72)$$

for all $\vec{x} \in L$ and all $\vec{h} \in L^*$. Considering Equation 2.70, we get

$$\mathbf{A} = \mathbf{A}^{-\top} \quad (2.73)$$

$$\mathbf{A}^\top \mathbf{A} = \mathbf{I} \quad (2.74)$$

Notice that this is, for instance, satisfied when \mathbf{A} is a rotation [5]. In such a case, one often does not anymore distinguish between vectors of L and L^* because they behave the same way and it is hence possible to represent linear functions from L^* by vectors of L .

§4 Coordinates of the basis dual to a general basis We denote the standard basis in \mathbb{R}^3 by σ and its dual (standard) basis in \mathbb{R}^{3^*} by σ^* . Now, we can further establish another basis $\gamma = [\vec{c}_1 \ \vec{c}_2 \ \vec{c}_3]$ in \mathbb{R}^3 and its dual basis $\gamma^* = [\vec{c}_1^* \ \vec{c}_2^* \ \vec{c}_3^*]$ in \mathbb{R}^{3^*} . We would like to find the coordinates $\gamma_{\sigma^*}^* = [\vec{c}_{1\sigma^*}^* \ \vec{c}_{2\sigma^*}^* \ \vec{c}_{3\sigma^*}^*]$ of vectors of γ^* w.r.t. σ^* as a function of coordinates $\gamma_\sigma = [\vec{c}_{1\sigma} \ \vec{c}_{2\sigma} \ \vec{c}_{3\sigma}]$ of vectors of γ w.r.t. σ .

Considering Equations 2.55 and 2.62, we are getting

$$\vec{c}_{i\sigma^*}^* \vec{c}_{j\sigma} = \begin{cases} 1 & \text{if } i = j \\ 0 & \text{if } i \neq j \end{cases} \quad \text{for } i, j = 1, 2, 3 \quad (2.75)$$

which can be rewritten in a matrix form as

$$\begin{bmatrix} 1 & 0 & 0 \\ 0 & 1 & 0 \\ 0 & 0 & 1 \end{bmatrix} = \begin{bmatrix} \vec{c}_{1\sigma^*}^\top \\ \vec{c}_{2\sigma^*}^\top \\ \vec{c}_{3\sigma^*}^\top \end{bmatrix} [\vec{c}_{1\sigma} \quad \vec{c}_{2\sigma} \quad \vec{c}_{3\sigma}] = \gamma_{\sigma^*}^\top \gamma_\sigma \quad (2.76)$$

and therefore

$$\gamma_{\sigma^*} = \gamma_\sigma^{-\top} \quad (2.77)$$

§5 Remark on higher dimensions We have introduced the dual space and the dual basis in a three-dimensional linear space. The definition of the dual space is exactly the same for any linear space. The definition of the dual basis is the same for all finite-dimensional linear spaces [4]. For any n -dimensional linear space L and its basis β , we get the corresponding n -dimensional dual space L^* with the dual basis β^* .

2.5 Operations with matrices

Matrices are a powerful tool which can be used in many ways. Here we review a few useful rules for matrix manipulation. The rules are often studied in multi-linear algebra and tensor calculus. We shall not review the theory of multi-linear algebra but will look at the rules from a phenomenological point of view. They are useful identities making an effective manipulation and concise notation possible.

§1 Kronecker product Let A be a $k \times l$ matrix and B be a $m \times n$ matrix

$$A = \begin{bmatrix} a_{11} & a_{12} & \cdots & a_{1l} \\ a_{21} & a_{22} & \cdots & a_{2l} \\ \vdots & \vdots & \ddots & \vdots \\ a_{k1} & a_{k2} & \cdots & a_{kl} \end{bmatrix} \in \mathbb{R}^{k \times l} \quad \text{and} \quad B \in \mathbb{R}^{m \times n} \quad (2.78)$$

then $km \times ln$ matrix

$$C = A \otimes B = \begin{bmatrix} a_{11} B & a_{12} B & \cdots & a_{1l} B \\ a_{21} B & a_{22} B & \cdots & a_{2l} B \\ \vdots & \vdots & \ddots & \vdots \\ a_{k1} B & a_{k2} B & \cdots & a_{kl} B \end{bmatrix} \quad (2.79)$$

is the matrix of the *Kronecker product of matrices* A, B (in this order).

Notice that this product is associative, i.e. $(A \otimes B) \otimes C = A \otimes (B \otimes C)$, but it is not commutative, i.e. $A \otimes B \neq B \otimes A$ in general. There holds a useful identity $(A \otimes B)^\top = A^\top \otimes B^\top$.

§2 Matrix vectorization Let A be an $m \times n$ matrix

$$A = \begin{bmatrix} a_{11} & a_{12} & \cdots & a_{1n} \\ a_{21} & a_{22} & \cdots & a_{2n} \\ \vdots & \vdots & \ddots & \vdots \\ a_{m1} & a_{m2} & \cdots & a_{mn} \end{bmatrix} \in \mathbb{R}^{m \times n} \quad (2.80)$$

We define operator $v(\cdot): \mathbb{R}^{m \times n} \rightarrow \mathbb{R}^{mn}$ which reshapes an $m \times n$ matrix \mathbf{A} into a $mn \times 1$ matrix (i.e. into a vector) by stacking columns of \mathbf{A} one above another

$$v(\mathbf{A}) = \begin{bmatrix} a_{11} \\ a_{21} \\ \vdots \\ a_{m1} \\ a_{12} \\ a_{22} \\ \vdots \\ a_{m2} \\ a_{1n} \\ a_{2n} \\ \vdots \\ a_{mn} \end{bmatrix} = \quad (2.81)$$

Let us study the relationship between $v(\mathbf{A})$ and $v(\mathbf{A}^\top)$. We see that vector $v(\mathbf{A}^\top)$ contains permuted elements of $v(\mathbf{A})$ and therefore we can construct permutation matrices [5] $\mathbb{T}_{m \times n}$ and $\mathbb{T}_{n \times m}$ such that

$$\begin{aligned} v(\mathbf{A}^\top) &= \mathbb{T}_{m \times n} v(\mathbf{A}) \\ v(\mathbf{A}) &= \mathbb{T}_{n \times m} v(\mathbf{A}^\top) \end{aligned}$$

We see that there holds

$$\mathbb{T}_{n \times m} \mathbb{T}_{m \times n} v(\mathbf{A}) = \mathbb{T}_{n \times m} v(\mathbf{A}^\top) = v(\mathbf{A}) \quad (2.82)$$

for every $m \times n$ matrix \mathbf{A} . Hence

$$\mathbb{T}_{n \times m} = \mathbb{T}_{m \times n}^{-1} \quad (2.83)$$

Consider a permutation \mathbb{T} . It has exactly one unit element in each row and in each column. Consider the i -th row with 1 in the j -th column. This row sends the j -th element of an input vector to the i -th element of the output vector. The i -th column of the transpose of \mathbb{T} has 1 in the j -th row. It is the only non-zero element in that row and therefore the j -th row of \mathbb{T}^\top sends the i -th element of an input vector to the j -th element of the output vector. We see that \mathbb{T}^\top is the inverse of \mathbb{T} , i.e. permutation matrices are orthogonal. We see that

$$\mathbb{T}_{m \times n}^{-1} = \mathbb{T}_{m \times n}^\top \quad (2.84)$$

and hence conclude

$$\mathbb{T}_{n \times m} = \mathbb{T}_{m \times n}^\top \quad (2.85)$$

We also write $v(\mathbf{A}) = \mathbb{T}_{m \times n}^\top v(\mathbf{A}^\top)$.

§ 3 From matrix equations to linear systems Kronecker product of matrices and matrix vectorization can be used to manipulate matrix equations in order to get systems of linear equations in the standard matrix form $\mathbf{A} \mathbf{x} = \mathbf{b}$. Consider, for instance, matrix equation

$$\mathbf{A} \mathbf{X} \mathbf{B} = \mathbf{C} \quad (2.86)$$

with matrices $\mathbf{A} \in \mathbb{R}^{m \times k}$, $\mathbf{X} \in \mathbb{R}^{k \times l}$, $\mathbf{B} \in \mathbb{R}^{l \times n}$, $\mathbf{C} \in \mathbb{R}^{m \times n}$. It can be verified by direct computation that

$$v(\mathbf{A} \mathbf{X} \mathbf{B}) = (\mathbf{B}^\top \otimes \mathbf{A}) v(\mathbf{X}) \quad (2.87)$$

This is useful when matrices \mathbf{A} , \mathbf{B} and \mathbf{C} are known and we use Equation 2.86 to compute \mathbf{X} . Notice that matrix Equation 2.86 is actually equivalent to mn scalar linear equations in kl unknown elements of \mathbf{X} . Therefore, we should be able to write it in the standard form, e.g., as

$$\mathbf{M} v(\mathbf{X}) = v(\mathbf{C}) \quad (2.88)$$

with some $\mathbf{M} \in \mathbb{R}^{(mn) \times (kl)}$. We can use Equation 2.87 to get $\mathbf{M} = \mathbf{B}^\top \otimes \mathbf{A}$ which yields the linear system

$$v(\mathbf{A} \mathbf{X} \mathbf{B}) = v(\mathbf{C}) \quad (2.89)$$

$$(\mathbf{B}^\top \otimes \mathbf{A}) v(\mathbf{X}) = v(\mathbf{C}) \quad (2.90)$$

for unknown $v(\mathbf{X})$, which is in the standard form.

Let us next consider two variations of Equation 2.86. First consider matrix equation

$$\mathbf{A} \mathbf{X} \mathbf{B} = \mathbf{X} \quad (2.91)$$

Here unknowns \mathbf{X} appear on both sides but we are still getting a linear system of the form

$$(\mathbf{B}^\top \otimes \mathbf{A} - \mathbf{I}) v(\mathbf{X}) = 0 \quad (2.92)$$

where \mathbf{I} is the $(mn) \times (kl)$ identity matrix.

Next, we add yet another constraints: $\mathbf{X}^\top = \mathbf{X}$, i.e. matrix \mathbf{X} is symmetric, to get

$$\mathbf{A} \mathbf{X} \mathbf{B} = \mathbf{X} \quad \text{and} \quad \mathbf{X}^\top = \mathbf{X} \quad (2.93)$$

which can be rewritten in the vectorized form as

$$(\mathbf{B}^\top \otimes \mathbf{A} - \mathbf{I}) v(\mathbf{X}) = 0 \quad \text{and} \quad (\mathbb{T}_{m \times n} - \mathbf{I}) v(\mathbf{X}) = 0 \quad (2.94)$$

and combined it into a single linear system

$$\begin{bmatrix} \mathbb{T}_{m \times n} - \mathbf{I} \\ \mathbf{B}^\top \otimes \mathbf{A} - \mathbf{I} \end{bmatrix} v(\mathbf{X}) = 0 \quad (2.95)$$

3 Affine space

Let us study the affine space, an important structure underlying geometry and its algebraic representation. The affine space is closely connected to the linear space. The connection is so intimate that the two spaces are sometimes not even distinguished. Consider, for instance, function $f: \mathbb{R} \rightarrow \mathbb{R}$ with non-zero $a, b \in \mathbb{R}$

$$f(x) = ax + b \tag{3.1}$$

It is often called “linear” but it is not a *linear function* [6, 7, 5] since for every $\alpha \in \mathbb{R}$ there holds

$$f(\alpha x) = \alpha ax + b \neq \alpha(ax + b) = \alpha f(x) \tag{3.2}$$

In fact, f is an *affine function*, which becomes a linear function only for $b = 0$.

In geometry, we need to be very precise and we have to clearly distinguish affine from linear. Let us therefore first review the very basics of linear spaces, and in particular their relationship to geometry, and then move to the notion of affine spaces.

3.1 Vectors

Let us start with geometric vectors and study the rules of their manipulation.

Figure 3.1(a) shows the space of points P , which we live in and intuitively understand. We know what is an oriented line segment, which we also call a *marked ruler* (or just a ruler). A marked ruler is oriented from its origin towards its end, which is actually a mark (represented

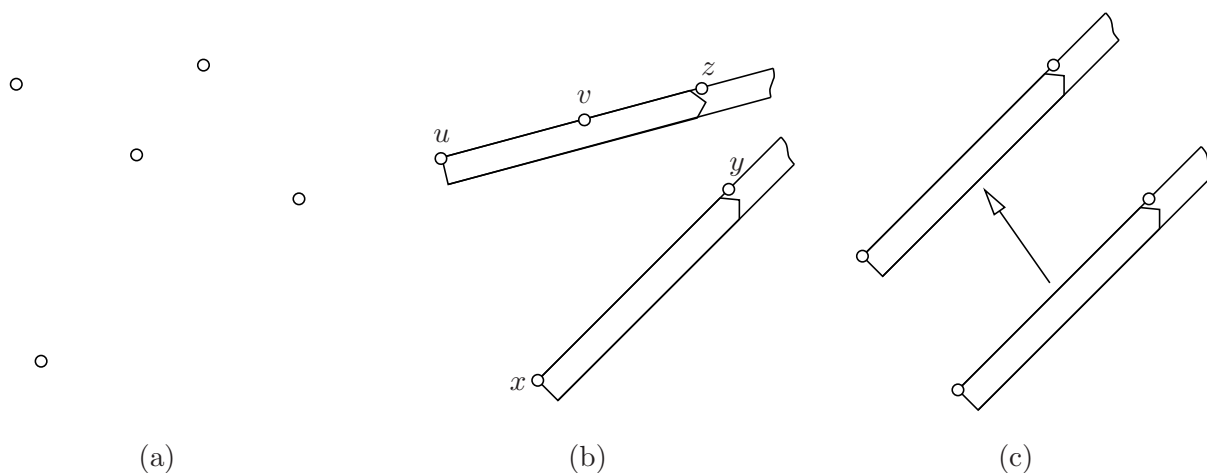

Figure 3.1: (a) The space around us consists of points. Rulers (marked oriented line segments) can be aligned (b) and translated (c) and thus used to transfer, but not measure, distances.

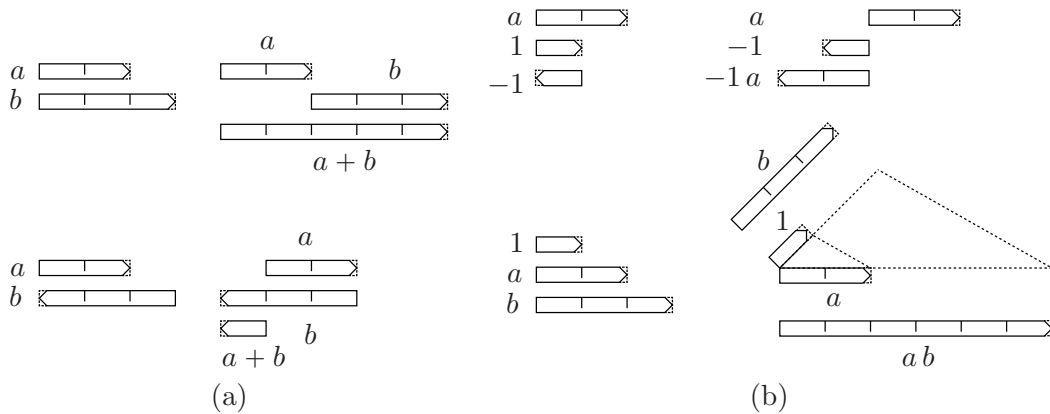

Figure 3.2: Scalars are represented by oriented rulers. They can be added (a) and multiplied (b) purely geometrically by translating and aligning rulers. Notice that we need to single out a unit scalar “1” to perform geometric multiplication.

by an arrow in Figure 3.1(b)) on a thought infinite ruler, Figure 3.1(b). We assume that we are able to align the ruler with any pair of points x, y , so that the ruler begins in x and a mark is made at the point y . We also know how to align a marked ruler with any pair of distinct points u, v such that the ruler begins in u and aligns with the line connecting u and v in the direction towards point v . The mark on so aligned ruler determines another point, call it z , which is collinear with points u, v . We know how to translate, Figure 3.1(c), a ruler in this space.

To define geometric vectors, we need to first define geometric scalars.

3.1.1 Geometric scalars

Geometric scalars S are horizontal oriented rulers. The ruler, which has its origin identical with its end is called 0. Geometric scalars are equipped with two geometric operations, addition $a + b$ and multiplication $a b$, defined for every two elements $a, b \in S$.

Figure 3.2(a) shows addition $a + b$. We translate ruler b to align origin of b with the end of a and obtain ruler $a + b$.

Figure 3.2(b) shows multiplication $a b$. To perform multiplication, we choose a unit ruler “1” and construct its additive inverse -1 using $1 + (-1) = 0$. This introduces orientation to scalars. Scalars aiming to the same side as 1 are *positive* and scalars aiming to the same side as -1 are *negative*. Scalar 0 is neither positive, nor negative. Next we define multiplication by -1 such that $-1 a = -a$, i.e. -1 times a equals the additive inverse of a . Finally, we define multiplication of non-negative (i.e. positive and zero) rulers a, b as follows. We align a with 1 such that origins of 1 and a coincide and such that the rulers contain an acute non-zero angle. We align b with 1 and construct ruler $a b$ by a translation, e.g. as shown in Figure 3.2(b)¹.

All constructions used were purely geometrical and were performed with real rulers. We can verify that so defined addition and multiplication of geometric scalars satisfy all rules of addition and multiplication of real numbers. Geometric scalars form a field [11, 14] w.r.t. to $a + b$ and $a b$.

¹Notice that $a b$ is well defined since it is the same for all non-zero angles contained by a and 1.

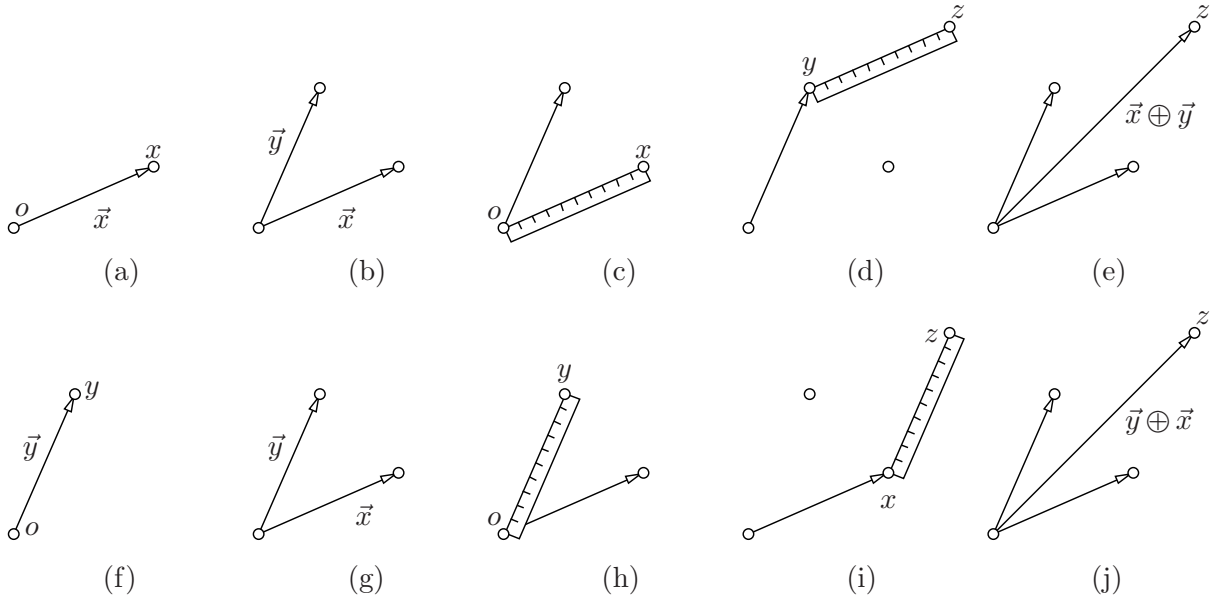

Figure 3.3: Bound vectors are (ordered) pairs of points (o, x) , i.e. arrows $\vec{x} = (o, x)$. Addition of the bound vectors \vec{x}, \vec{y} is realized by parallel transport (using a ruler). We see that the result is the same whether we add \vec{x} to \vec{y} or \vec{y} to \vec{x} . Addition is commutative.

3.1.2 Geometric vectors

Ordered pairs of points, such as (x, y) in Figure 3.3(a), are called *geometric vectors* and denoted as \vec{xy} , i.e. $\vec{xy} = (x, y)$. Symbol \vec{xy} is often replaced by a simpler one, e.g. by \vec{a} . The set of all geometric vectors is denoted by A .

3.1.3 Bound vectors

Let us now choose one point o and consider all pairs (o, x) , where x can be any point, Figure 3.3(a). We obtain a subset A_o of A , which we call *geometric vectors bound to o* , or just *bound vectors* when it is clear to which point they are bound. We will write $\vec{x} = (o, x)$. Figure 3.3(f) shows another bound vector \vec{y} . The pair (o, o) is special. It will be called the *zero bound vector* and denoted by $\vec{0}$. We will introduce two operations \oplus, \odot with bound vectors.

First we define *addition of bound vectors* $\oplus: A_o \times A_o \rightarrow A_o$. Let us add vector \vec{x} to \vec{y} as shown on Figure 3.3(b). We take a ruler and align it with \vec{x} , Figure 3.3(c). Then we translate the ruler to align its begin with point y , Figure 3.3(d). The end of the ruler determines point z . We define a new bound vector, which we denote $\vec{x} \oplus \vec{y}$, as the pair (o, z) , Figure 3.3(e). Figures 3.3(f-j) demonstrate that addition gives the same result when we exchange (*commute*) vectors \vec{x} and \vec{y} , i.e. $\vec{x} \oplus \vec{y} = \vec{y} \oplus \vec{x}$. We notice that for every point x , there is exactly one point x' such that $(o, x) \oplus (o, x') = (o, o)$, i.e. $\vec{x} \oplus \vec{x}' = \vec{0}$. Bound vector \vec{x}' is the *inverse* to \vec{x} and is denoted as $-\vec{x}$. Bound vectors are invertible w.r.t. operation \oplus . Finally, we see that $(o, x) \oplus (o, o) = (o, x)$, i.e. $\vec{x} \oplus \vec{0} = \vec{x}$. Vector $\vec{0}$ is the *identity element* of the operation \oplus . Clearly, operation \oplus behaves exactly as addition of scalars – it is a commutative group [11, 14].

Secondly, we define the *multiplication of a bound vector by a geometric scalar* $\odot: S \times A_o \rightarrow A_o$,

where S are geometric scalars and A_o are bound vectors. Operation \odot is a mapping which takes a geometric scalar (a ruler) and a bound vector and delivers another bound vector.

Figure 3.4 shows that to multiply a bound vector $\vec{x} = (o, x)$ by a geometric scalar a , we consider the ruler b whose origin can be aligned with o and end with x . We multiply scalars a and b to obtain scalar ab and align ab with \vec{x} such that the origin of ab coincides with o and ab extends along the line passing through \vec{x} . We obtain end point y of so placed ab and construct the resulting vector $\vec{y} = a \odot \vec{x} = (o, y)$.

We notice that addition \oplus and multiplication \odot of horizontal bound vectors coincides exactly with the addition and multiplication of scalars.

3.2 Linear space

We can verify that for every two geometric scalars $a, b \in S$ and every three bound vectors $\vec{x}, \vec{y}, \vec{z} \in A_o$ with their respective operations, there holds the following eight rules

$$\vec{x} \oplus (\vec{y} \oplus \vec{z}) = (\vec{x} \oplus \vec{y}) \oplus \vec{z} \tag{3.3}$$

$$\vec{x} \oplus \vec{y} = \vec{y} \oplus \vec{x} \tag{3.4}$$

$$\vec{x} \oplus \vec{0} = \vec{x} \tag{3.5}$$

$$\vec{x} \oplus -\vec{x} = \vec{0} \tag{3.6}$$

$$1 \odot \vec{x} = \vec{x} \tag{3.7}$$

$$(ab) \odot \vec{x} = a \odot (b \odot \vec{x}) \tag{3.8}$$

$$a \odot (\vec{x} \oplus \vec{y}) = (a \odot \vec{x}) \oplus (a \odot \vec{y}) \tag{3.9}$$

$$(a + b) \odot \vec{x} = (a \odot \vec{x}) \oplus (b \odot \vec{x}) \tag{3.10}$$

These rules are known as axioms of a *linear space* [6, 7, 4]. Bound vectors are one particular model of the linear space. There are many other very useful models, e.g. n-tuples of real or rational numbers for any natural n , polynomials, series of real numbers and real functions. We will give some particularly simple examples useful in geometry later.

The next concept we will introduce are *coordinates of bound vectors*. To illustrate this concept, we will work in a plane. Figure 3.5 shows two non-collinear bound vectors \vec{b}_1, \vec{b}_2 , which we call *basis*, and another bound vector \vec{x} . We see that there is only one way how to choose scalars x_1 and x_2 such that vectors $x_1 \odot \vec{b}_1$ and $x_2 \odot \vec{b}_2$ add to \vec{x} , i.e.

$$\vec{x} = x_1 \odot \vec{b}_1 \oplus x_2 \odot \vec{b}_2 \tag{3.11}$$

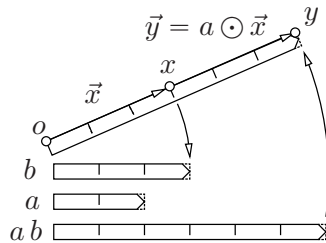

Figure 3.4: Multiplication of the bound vector \vec{x} by a geometric scalar a is realized by aligning rulers to vectors and multiplication of geometric scalars.

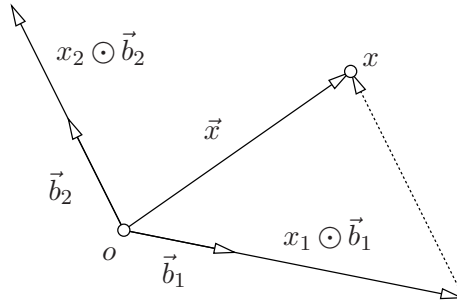

Figure 3.5: Coordinates are the unique scalars that combine independent basic vectors \vec{b}_1, \vec{b}_2 into \vec{x} .

Scalars x_1, x_2 are *coordinates* of \vec{x} in (ordered) basis $[\vec{b}_1, \vec{b}_2]$.

3.3 Free vectors

We can choose any point from A to construct bound vectors and all such choices will lead to the same manipulation of bound vector and to the same axioms of a linear space. Figure 3.6 shows two such choices for points o and o' .

We take bound vectors $\vec{b}_1 = (o, b_1), \vec{b}_2 = (o, b_2), \vec{x} = (o, x)$ at o and construct bound vectors $\vec{b}'_1 = (o', b'_1), \vec{b}'_2 = (o', b'_2), \vec{x}' = (o', x')$ at o' by translating x to x', b_1 to b'_1 and b_2 to b'_2 by the same translation. Coordinates of \vec{x} w.r.t. $[\vec{b}_1, \vec{b}_2]$ are equal to coordinates of \vec{x}' w.r.t. $[\vec{b}'_1, \vec{b}'_2]$. This interesting property allows us to construct another model of a linear space, which plays an important role in geometry.

Let us now consider the set of all geometric vectors A . Figure 3.7(a) shows an example of a few points and a few geometric vectors. Let us *partition* [1] the set A of geometric vectors into disjoint subsets $A_{(o,x)}$ such that we choose one bound vector (o, x) and put to $A_{(o,x)}$ all geometric vectors that can be obtained by a translation of (o, x) . Figure 3.7(b) shows two such partitions $A_{(o,x)}, A_{(o,y)}$. It is clear that $A_{(o,x)} \cap A_{(o,x')} = \emptyset$ for $x \neq x'$ and that every geometric vector is in some (and in exactly one) subset $A_{(o,x)}$.

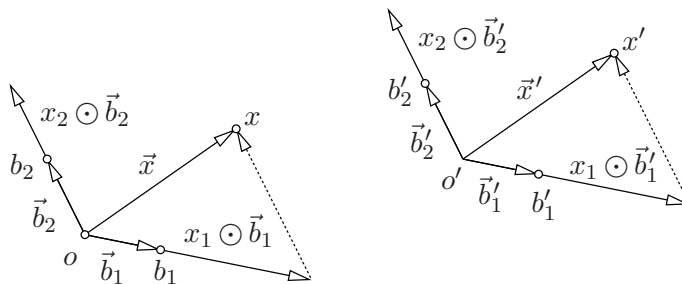

Figure 3.6: Two sets of bound vectors A_o and $A_{o'}$. Coordinates of \vec{x} w.r.t. $[\vec{b}_1, \vec{b}_2]$ are equal to coordinates of \vec{x}' w.r.t. $[\vec{b}'_1, \vec{b}'_2]$.

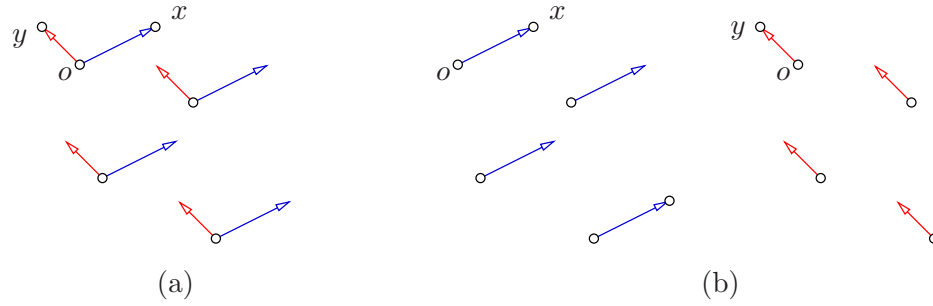

Figure 3.7: The set A of all geometric vectors (a) can be partitioned into subsets which are called free vectors. Two free vectors $A_{(o,x)}$ and $A_{(o,y)}$, i.e. subsets of A , are shown in (b).

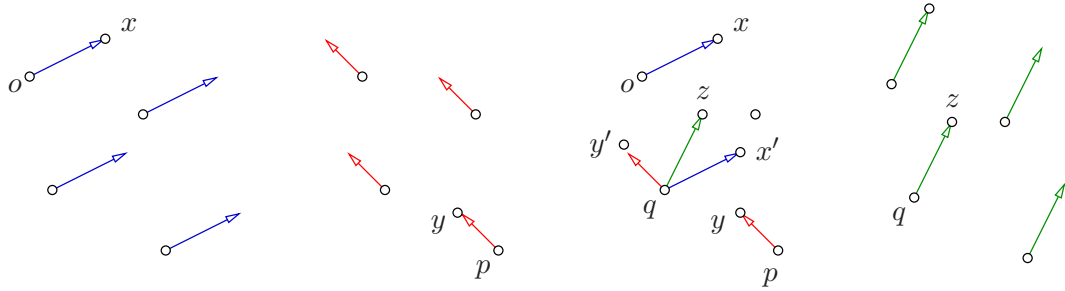

Figure 3.8: Free vector $A_{(o,x)}$ is added to free vector $A_{(p,y)}$ by translating (o, x) to (q, x') and (p, y) to (q, y') , adding bound vectors $(q, z) = (q, x') \oplus (q, y')$ and setting $A_{(o,x)} \boxplus A_{(p,y)} = A_{(q,z)}$

Two geometric vectors (o, x) and (o', x') form two subsets $A_{(o,x)}$, $A_{(o',x')}$ which are equal if and only if (o', x') is related by a translation to (o, x) .

“To be related by a translation” is an equivalence relation [1]. All geometric vectors in $A_{(o,x)}$ are equivalent to (o, x) .

There are as many sets in the partition as there are bound vectors at a point. We can define the partition by geometric vectors bound to any point o because if we choose another point o' , then for every point x , there is exactly one point x' such that (o, x) can be translated to (o', x') .

We denote the set of subsets $A_{(o,x)}$ by V . Let us see that we can equip set V with a meaningful addition $\boxplus: V \times V \rightarrow V$ and multiplication $\boxtimes: S \times V \rightarrow V$ by geometrical scalars S such that it will become a model of the linear space. Elements of V will be called *free vectors*.

We define the sum of $\vec{x} = A_{(o,x)}$ and $\vec{y} = A_{(o,y)}$, i.e. $\vec{z} = \vec{x} \boxplus \vec{y}$ is the set $A_{(o,x) \oplus (o,y)}$. Multiplication of $\vec{x} = A_{(o,x)}$ by geometrical scalar a is defined analogically, i.e. $a \boxtimes \vec{x}$ equals the set $A_{a \odot (o,x)}$. We see that the result of \boxplus and \boxtimes does not depend on the choice of o . We have constructed the linear space V of free vectors.

§ 1 Why so many vectors? In the literature, e.g. in [4, 5, 8], linear spaces are often treated purely axiomatically and their geometrical models based on geometrical scalars and vectors are not studied in detail. This is a good approach for a pure mathematician but in engineering we

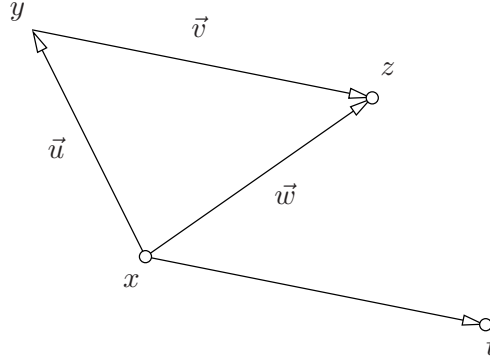

Figure 3.9: Free vectors \vec{u} , \vec{v} and \vec{w} defined by three points x , y and z satisfy triangle identity $\vec{u} \boxplus \vec{v} = \vec{w}$.

use the geometrical model to study the space we live in. In particular, we wish to appreciate that good understanding of the geometry of the space around us calls for using bound as well as free vectors.

3.4 Affine space

We saw that bound vectors and free vectors were (models of) a linear space. On the other hand, we see that the set of geometric vectors A is not (a model of) a linear space because we do not know how to meaningfully add (by translation) geometric vectors which are not bound to the same point. The set of geometric vectors is an *affine space*.

The affine space connects points, geometric scalars, bound geometric vectors and free vectors in a natural way.

Two points x and y , in this order, give one geometric vector (x, y) , which determines exactly one free vector $\vec{v} = A_{(x,y)}$. We define function $\varphi: A \rightarrow V$, which assigns to two points $x, y \in P$ their corresponding free vector $\varphi(x, y) = A_{(x,y)}$.

Consider a point $a \in P$ and a free vector $\vec{x} \in V$. There is exactly one geometric vector (a, x) , with a at the first position, in the free vector \vec{x} . Therefore, point a and free vector \vec{x} uniquely define point x . We define function $\# : P \times V \rightarrow P$, which takes a point and a free vector and delivers another point. We write $a \# \vec{x} = x$ and require $\vec{x} = \varphi(a, x)$.

Consider three points $x, y, z \in P$, Figure 3.9. We can produce three free vectors $\vec{u} = \varphi(x, y) = A_{(x,y)}$, $\vec{v} = \varphi(y, z) = A_{(y,z)}$, $\vec{w} = \varphi(x, z) = A_{(x,z)}$. Let us investigate the sum $\vec{u} \boxplus \vec{v}$. Chose the representatives of the free vectors, such that they are all bound to x , i.e. bound vectors $(x, y) \in A_{x,y}$, $(x, t) \in A_{(y,z)}$ and $(x, z) \in A_{(x,z)}$. Notice that we could choose the pairs of original points, (x, t) , to represent the second free vector. Clearly, there holds $(x, y) \oplus (x, t) = (x, z)$. We now see, Figure 3.9, that (y, z) is related to (x, t) by a translation and therefore

$$\vec{u} \boxplus \vec{v} = A_{(x,y)} \boxplus A_{(y,z)} = A_{(x,y)} \boxplus A_{(x,t)} = A_{(x,y) \oplus (x,t)} = A_{(x,z)} = \vec{w} \quad (3.12)$$

Figure 3.10 shows the operations explained above in Figure 3.9 but realized using the vectors bound to another point o .

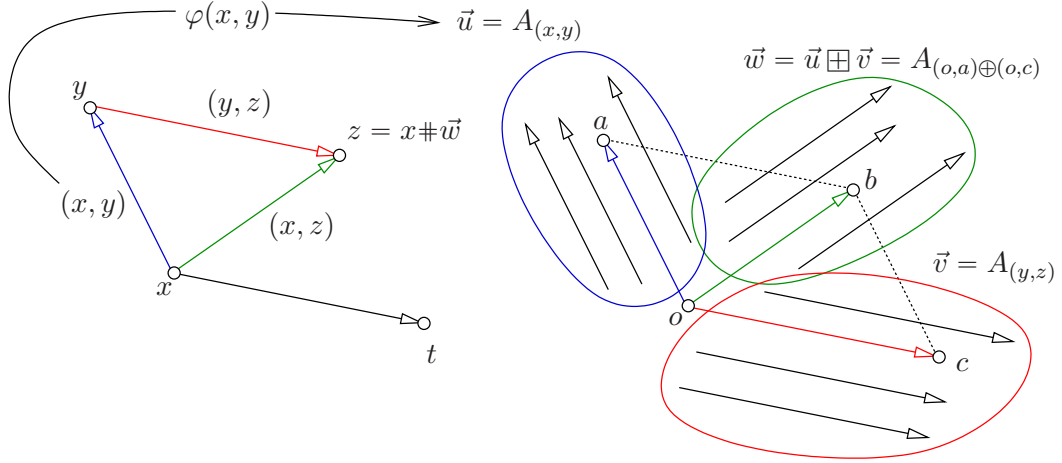

Figure 3.10: Affine space (P, L, φ) , its geometric vectors $(x, y) \in A = P \times P$ and free vector space L and the canonical assignment of pairs of points (x, y) to the free vector $A_{(x,y)}$. Operations \oplus, \boxplus , combining vectors with vectors, and $\#$, combining points with vectors, are illustrated.

The above rules are known as *axioms of affine space* and can be used to define even more general affine spaces.

§ 1 Remark on notation We were carefully distinguishing operations $(+, \cdot)$ over scalars, (\oplus, \odot) over bound vectors, (\boxplus, \boxdot) over free vectors, and function $\#$ combining points and free vectors. This is very correct but rarely used. Often, only the symbols introduced for geometric scalars are used for all operations, i.e.

$$+ \equiv +, \oplus, \boxplus, \# \tag{3.13}$$

$$\equiv \cdot, \odot, \boxdot \tag{3.14}$$

§ 2 Affine space Triple (P, L, φ) with a set of points P , linear space (L, \boxplus, \boxdot) (over some field of scalars) and a function $\varphi: P \times P \rightarrow L$, is an affine space when

A1 $\varphi(x, z) = \varphi(x, y) \boxplus \varphi(y, z)$ for every three points $x, y, z \in P$

A2 for every $o \in P$, the function $\varphi_o: P \rightarrow L$, defined by $\varphi_o(x) = \varphi(o, x)$ for all $x \in P$ is a bijection [1].

Axiom A1 calls for an assignment of pairs of point to vectors. Axiom A2 then makes this assignmet such that it is one-to-one when the first argument of φ is fixed.

We can define another function $\#: P \times L \rightarrow P$, defined by $o \# \vec{x} = \varphi_o^{-1}(\vec{x})$, which means $\varphi(o, o \# \vec{x}) = \vec{x}$ for all $\vec{x} \in L$. This function combines points and vectors in a way that is very similar to addition and hence is sometimes denoted by $+$ instead of more correct $\#$.

In our geometrical model of A discussed above, function φ assigned to a pair of points x, y their corresponding free vector $A_{(x,y)}$. Function $\#$, on the other hand, takes a point x and a free vector \vec{v} and gives another points y such that the bound vector (x, y) is a representative of \vec{v} , i.e. $A_{(x,y)} = \vec{v}$.

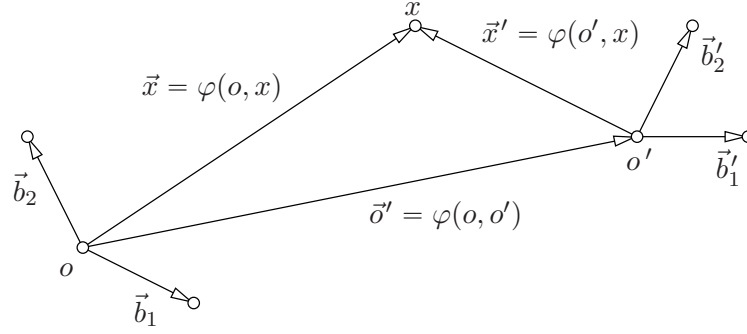

Figure 3.11: Point x is represented in two affine coordinate systems.

3.5 Coordinate system in affine space

We see that function φ assigns the same vector from L to many different pairs of points from P . To represent uniquely points by vectors, we select a point o , called the *origin of affine coordinate system* and represent point $x \in P$ by its *position vector* $\vec{x} = \varphi(o, x)$. In our geometric model of A discussed above, we thus represent point x by bound vector (o, x) or by point o and free vector $A_{(o,x)}$.

To be able to compute with points, we now pass to the representation of points in A by coordinate vectors. We choose a basis $\beta = (\vec{b}_1, \vec{b}_2, \dots)$ in L . That allows us to represent point $x \in P$ by a coordinate vector

$$\vec{x}_\beta = \begin{bmatrix} x_1 \\ x_2 \\ \vdots \end{bmatrix}, \quad \text{such that} \quad \vec{x} = x_1 \vec{b}_1 + x_2 \vec{b}_2 + \dots \quad (3.15)$$

The pair (o, β) , where $o \in P$ and β is a basis of L is called an *affine coordinate system* (often shortly called just coordinate system) of affine space (P, L, φ) .

Let us now study what happens when we choose another point o' and another basis $\beta' = (\vec{b}'_1, \vec{b}'_2, \dots)$ to represent $x \in P$ by coordinate vectors, Figure 3.11. Point x is represented twice: by coordinate vector $\vec{x}_\beta = \varphi(o, x)_\beta = A_{(o,x)\beta}$ and by coordinate vector $\vec{x}'_{\beta'} = \varphi(o', x)_{\beta'} = A_{(o',x)\beta'}$.

To get the relationship between the coordinate vectors \vec{x}_β and $\vec{x}'_{\beta'}$, we employ the triangle equality

$$\varphi(o, x) = \varphi(o, o') \boxplus \varphi(o', x) \quad (3.16)$$

$$\vec{x} = \vec{o}' \boxplus \vec{x}' \quad (3.17)$$

which we can write in basis β as (notice that we replace \boxplus by $+$ to emphasize that we are adding coordinate vectors)

$$\vec{x}_\beta = \vec{x}'_{\beta'} + \vec{o}'_\beta \quad (3.18)$$

and use the matrix \mathbf{A} transforming coordinates of vectors from basis β' to β to get the desired relationship

$$\vec{x}_\beta = \mathbf{A} \vec{x}'_{\beta'} + \vec{o}'_\beta \quad (3.19)$$

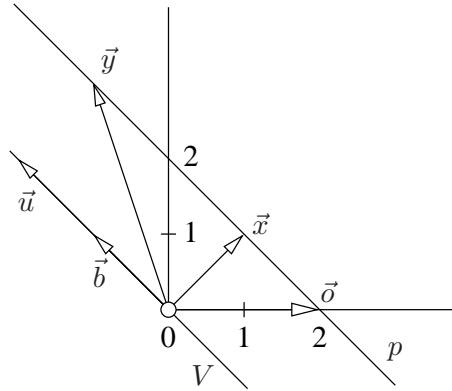

Figure 3.12: Affine space (P, V, φ) of solutions to a linear system is the set of vectors representing points on line p . In coordinate system (\vec{o}, \vec{u}) , vector \vec{x} has coordinate 1. The subspace V of solutions to the associated homogeneous system is the associated linear space. Function φ assigns to two points \vec{o}, \vec{x} the vector $\vec{u} = \vec{y} - \vec{x}$.

Columns of \mathbf{A} correspond to coordinate vectors $\vec{b}'_{1\beta}, \vec{b}'_{2\beta}, \dots$. When presented with a situation in a real affine space, we can measure those coordinates by a ruler on a particular representation of L by geometrical vectors bound to, e.g., point o .

3.6 An example of affine space

Let us now present an important example of affine space.

3.6.1 Affine space of solutions of a system of linear equations

When looking at the following system of linear equations in \mathbb{R}^2

$$\begin{bmatrix} 1 & 1 \\ -1 & -1 \end{bmatrix} \vec{x} = \begin{bmatrix} 2 \\ -2 \end{bmatrix} \quad (3.20)$$

we immediately see that there is an infinite number of solutions. They can be written as

$$\vec{x} = \begin{bmatrix} 2 \\ 0 \end{bmatrix} + \tau \begin{bmatrix} 1 \\ -1 \end{bmatrix}, \quad \tau \in \mathbb{R} \quad (3.21)$$

or as a sum of a particular solution $[2, 0]^\top$ and the set of solutions $\vec{v} = \tau [-1, 1]^\top$ of the accompanied homogeneous system

$$\begin{bmatrix} 1 & 1 \\ -1 & -1 \end{bmatrix} \vec{v} = \begin{bmatrix} 0 \\ 0 \end{bmatrix} \quad (3.22)$$

Figure 3.12 shows that the affine space (P, V, φ) of solutions to the linear system (3.20) is the set of vectors representing points on line p . The subspace V of solutions to the accompanied homogeneous system (3.22) is the linear space associated to A by function φ , which assigns to

two points $\vec{x}, \vec{y} \in A$ the vector $\vec{u} = \vec{y} - \vec{x} \in V$. If we choose $\vec{o} = [2, 0]^\top$ as the origin in A and vector $\vec{b} = \varphi(\vec{o}, \vec{x}) = \vec{x} - \vec{o}$ as the basis of V , vector \vec{x} has coordinate 1.

We see that, in this example, points of A are actually vectors of \mathbb{R}^2 , which are the solution to the system (3.20). The vectors of V are the vectors of \mathbb{R}^2 , which are solutions to the associated homogeneous linear system (3.22).

4 Motion

Let us introduce a mathematical model of rigid motion in three-dimensional Euclidean space. The important property of rigid motion is that it only relocates objects without changing their shape. Distances between points on rigidly moving objects remain unchanged. For brevity, we will use “motion” for “rigid motion”.

4.1 Change of position vector coordinates induced by motion

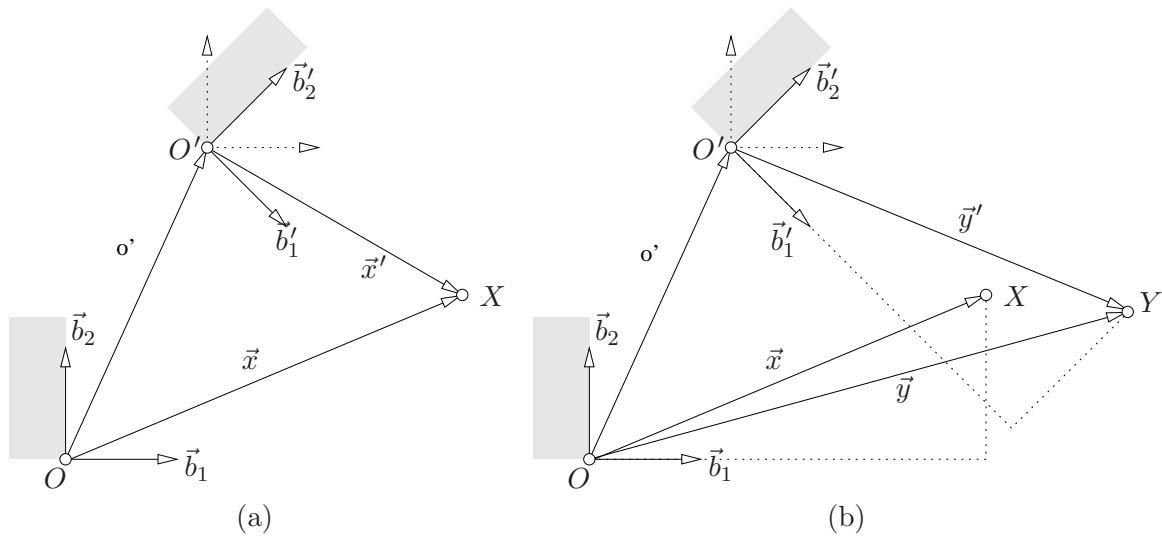

Figure 4.1: Representation of motion. (a) Alias representation: Point X is represented in two coordinate systems. (b) Alibi representation: Point X move together with the coordinate system into point Y .

§1 Alias representation of motion¹. Figure 4.1(a) illustrates a model of motion using coordinate systems, points and their position vectors. A coordinate system (O, β) with origin O and basis β is attached to a moving rigid body. As the body moves to a new position, a new coordinate system (O', β') is constructed. Assume a point X in a general position w.r.t. the body, which is represented in the coordinate system (O, β) by its position vector \vec{x} . The same point X is represented in the coordinate system (O', β') by its position vector \vec{x}' . The motion induces a mapping $\vec{x}'_{\beta'} \mapsto \vec{x}_{\beta}$. Such a mapping also determines the motion itself and provides its convenient mathematical model.

¹The terms *alias* and *alibi* were introduced in the classical monograph [14].

Let us derive the formula for the mapping $\vec{x}'_{\beta'} \mapsto \vec{x}_{\beta}$ between the coordinates $\vec{x}'_{\beta'}$ of vector \vec{x}' and coordinates \vec{x}_{β} of vector \vec{x} . Consider the following equations:

$$\vec{x} = \vec{x}' + \vec{o}' \quad (4.1)$$

$$\vec{x}_{\beta} = \vec{x}'_{\beta'} + \vec{o}'_{\beta} \quad (4.2)$$

$$\vec{x}_{\beta} = \begin{bmatrix} \vec{b}'_{1\beta} & \vec{b}'_{2\beta} & \vec{b}'_{3\beta} \end{bmatrix} \vec{x}'_{\beta'} + \vec{o}'_{\beta} \quad (4.3)$$

$$\vec{x}_{\beta} = \mathbf{R} \vec{x}'_{\beta'} + \vec{o}'_{\beta} \quad (4.4)$$

Vector \vec{x} is the sum of vectors \vec{x}' and \vec{o}' , Equation 4.1. We can express all vectors in (the same) basis β , Equation 4.2. To pass to the basis β' we introduce matrix $\mathbf{R} = \begin{bmatrix} \vec{b}'_{1\beta} & \vec{b}'_{2\beta} & \vec{b}'_{3\beta} \end{bmatrix}$, which transforms the coordinates of vectors from β' to β , Equation 4.4. Columns of matrix \mathbf{R} are coordinates $\vec{b}'_{1\beta}, \vec{b}'_{2\beta}, \vec{b}'_{3\beta}$ of basic vectors $\vec{b}'_1, \vec{b}'_2, \vec{b}'_3$ of basis β' in basis β .

§ 2 Alibi representation of motion. An alternative model of motion can be developed from the relationship between the points X and Y and their position vectors in Figure 4.1(b). The point Y is obtained by moving point X altogether with the moving object. It means that the coordinates $\vec{y}'_{\beta'}$ of the position vector \vec{y}' of Y in the coordinate system (O', β') equal the coordinates \vec{x}_{β} of the position vector \vec{x} of X in the coordinate system (O, β) , i.e.

$$\begin{aligned} \vec{y}'_{\beta'} &= \vec{x}_{\beta} \\ \vec{y}_{\beta'} - \vec{o}'_{\beta'} &= \vec{x}_{\beta} \\ \mathbf{R}^{-1} (\vec{y}_{\beta} - \vec{o}'_{\beta}) &= \vec{x}_{\beta} \\ \vec{y}_{\beta} &= \mathbf{R} \vec{x}_{\beta} + \vec{o}'_{\beta} \end{aligned} \quad (4.5)$$

Equation 4.5 describes how is the point X moved to point Y w.r.t. the coordinate system (O, β) .

4.2 Rotation matrix

Motion that leaves at least one point fixed is called rotation. Choosing such a fixed point as the origin leads to $O = O'$ and hence to $\vec{o} = \vec{0}$. The motion is then fully described by matrix \mathbf{R} , which is called *rotation matrix*.

§ 1 Two-dimensional rotation. To understand the matrix \mathbf{R} , we shall start with an experiment in two-dimensional plane. Imagine a right-angled triangle ruler as shown in Figure 4.2(a) with arms of equal length and let us define a coordinate system as in the figure. Next, rotate the triangle ruler around its tip, i.e. around the origin O of the coordinate system. We know, and we can verify it by direct physical measurement, that, thanks to the symmetry of the situation, the parallelograms through the tips of \vec{b}'_1 and \vec{b}'_2 and along \vec{b}_1 and \vec{b}_2 will be rotated by 90 degrees. We see that

$$\vec{b}'_1 = a_{11} \vec{b}_1 + a_{21} \vec{b}_2 \quad (4.6)$$

$$\vec{b}'_2 = -a_{21} \vec{b}_1 + a_{11} \vec{b}_2 \quad (4.7)$$

for some real numbers a_{11} and a_{21} . By comparing it with Equation 4.3, we conclude that

$$\mathbf{R} = \begin{bmatrix} a_{11} & -a_{21} \\ a_{21} & a_{11} \end{bmatrix} \quad (4.8)$$

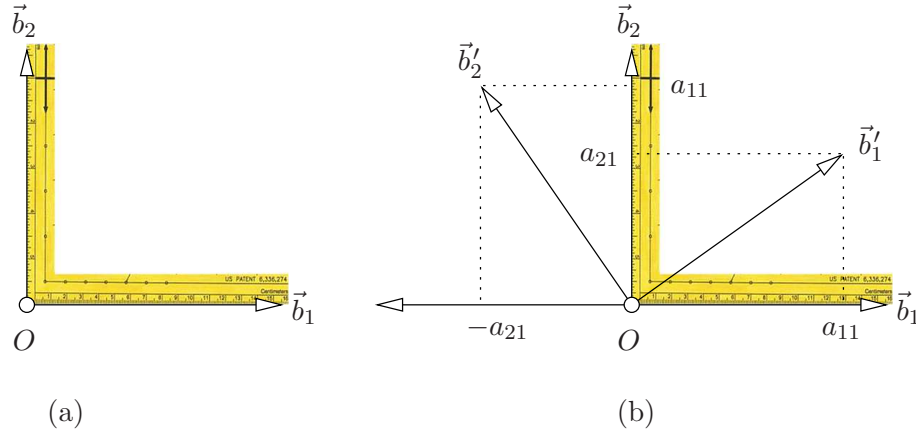

Figure 4.2: Rotation in two-dimensional space.

We immediately see that

$$\mathbf{R}^\top \mathbf{R} = \begin{bmatrix} a_{11} & a_{21} \\ -a_{21} & a_{11} \end{bmatrix} \begin{bmatrix} a_{11} & -a_{21} \\ a_{21} & a_{11} \end{bmatrix} = \begin{bmatrix} a_{11}^2 + a_{21}^2 & 0 \\ 0 & a_{11}^2 + a_{21}^2 \end{bmatrix} = \begin{bmatrix} 1 & 0 \\ 0 & 1 \end{bmatrix} \quad (4.9)$$

since $(a_{11}^2 + a_{21}^2)$ is the squared length of the basic vector of b_1 , which is one. We derived an interesting result

$$\mathbf{R}^{-1} = \mathbf{R}^\top \quad (4.10)$$

$$\mathbf{R} = \mathbf{R}^{-\top} \quad (4.11)$$

Next important observation is that for coordinates \vec{x}_β and $\vec{x}'_{\beta'}$, related by a rotation, there holds true

$$(x')^2 + (y')^2 = \vec{x}'_{\beta'}^\top \vec{x}'_{\beta'} = (\mathbf{R} \vec{x}_\beta)^\top \mathbf{R} \vec{x}_\beta = \vec{x}_\beta^\top (\mathbf{R}^\top \mathbf{R}) \vec{x}_\beta = \vec{x}_\beta^\top \vec{x}_\beta = x^2 + y^2 \quad (4.12)$$

Now, if the basis β was constructed as in Figure 4.2, in which case it is called an *orthonormal basis*, then the parallelogram used to measure coordinates x, y of \vec{x} is a rectangle, and hence $x^2 + y^2$ is the squared length of \vec{x} by the Pythagoras theorem. If β' is related by rotation to β , then also $(x')^2 + (y')^2$ is the squared length of \vec{x} , again thanks to the Pythagoras theorem.

We see that $\vec{x}_\beta^\top \vec{x}_\beta$ is the squared length of \vec{x} when β is orthonormal and that this length is preserved by computing it in the same way from the new coordinates of \vec{x} in the new coordinate system after motion. The change of coordinates induced by motion is modeled by rotation matrix \mathbf{R} , which has the desired property $\mathbf{R}^\top \mathbf{R} = \mathbf{I}$ when the bases β, β' are both orthonormal.

§2 Three-dimensional rotation. Let us now consider three dimensions. It would be possible to generalize Figure 4.2 to three dimensions, construct orthonormal bases, and use rectangular parallelograms to establish the relationship between elements of \mathbf{R} in three dimensions. However, the figure and the derivations would become much more complicated.

We shall follow a more intuitive path instead. Consider that we have found that with two-dimensional orthonormal bases, the lengths of vectors could be computed by the Pythagoras theorem since the parallelograms determining the coordinates were rectangular. To achieve this in three dimensions, we need (and can!) use bases consisting of three orthogonal vectors.

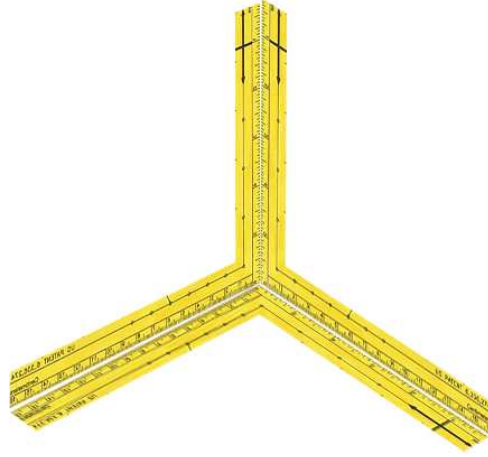

Figure 4.3: A three-dimensional coordinate system.

Then, again, the parallelograms will be rectangular and hence the Pythagoras theorem for three dimensions can be used analogically as in two dimensions, Figure 4.3.

Considering orthonormal bases β, β' , we require the following to hold true for all vectors \vec{x} with $\vec{x}_\beta = [x \ y \ z]^\top$ and $\vec{x}'_{\beta'} = [x' \ y' \ z']^\top$

$$\begin{aligned}
 (x')^2 + (y')^2 + (z')^2 &= x^2 + y^2 + z^2 \\
 \vec{x}'_{\beta'}{}^\top \vec{x}'_{\beta'} &= \vec{x}_\beta{}^\top \vec{x}_\beta \\
 (\mathbf{R} \vec{x}_\beta)^\top \mathbf{R} \vec{x}_\beta &= \vec{x}_\beta{}^\top \vec{x}_\beta \\
 \vec{x}_\beta{}^\top (\mathbf{R}^\top \mathbf{R}) \vec{x}_\beta &= \vec{x}_\beta{}^\top \vec{x}_\beta \\
 \vec{x}_\beta{}^\top \mathbf{C} \vec{x}_\beta &= \vec{x}_\beta{}^\top \vec{x}_\beta
 \end{aligned} \tag{4.13}$$

Equation 4.13 must hold true for all vectors \vec{x} and hence also for special vectors such as those with coordinates

$$\begin{bmatrix} 1 \\ 0 \\ 0 \end{bmatrix}, \begin{bmatrix} 0 \\ 1 \\ 0 \end{bmatrix}, \begin{bmatrix} 0 \\ 0 \\ 1 \end{bmatrix}, \begin{bmatrix} 1 \\ 1 \\ 0 \end{bmatrix}, \begin{bmatrix} 1 \\ 0 \\ 1 \end{bmatrix}, \begin{bmatrix} 0 \\ 1 \\ 1 \end{bmatrix} \tag{4.14}$$

Let us see what that implies, e.g., for the first vector

$$[1 \ 0 \ 0] \mathbf{C} \begin{bmatrix} 1 \\ 0 \\ 0 \end{bmatrix} = 1 \tag{4.15}$$

$$c_{11} = 1 \tag{4.16}$$

Taking the second and the third vector leads similarly to $c_{22} = c_{33} = 1$. Now, let's try the fourth

vector

$$\begin{bmatrix} 1 & 1 & 0 \end{bmatrix} \mathbf{C} \begin{bmatrix} 1 \\ 1 \\ 0 \end{bmatrix} = 2 \quad (4.17)$$

$$1 + c_{12} + c_{21} + 1 = 2 \quad (4.18)$$

$$c_{12} + c_{21} = 0 \quad (4.19)$$

Again, taking the fifth and the sixth vector leads to $c_{13} + c_{31} = c_{23} + c_{32} = 0$. This brings us to the following form of \mathbf{C}

$$\mathbf{C} = \begin{bmatrix} 1 & c_{12} & c_{13} \\ -c_{12} & 1 & c_{23} \\ -c_{13} & -c_{23} & 1 \end{bmatrix} \quad (4.20)$$

Moreover, we see that \mathbf{C} is symmetric since

$$\mathbf{C}^\top = (\mathbf{R}^\top \mathbf{R})^\top = \mathbf{R}^\top \mathbf{R} = \mathbf{C} \quad (4.21)$$

which leads to $-c_{12} = c_{12}$, $-c_{13} = c_{13}$ and $-c_{23} = c_{23}$, i.e. $c_{12} = c_{13} = c_{23} = 0$ and allows us to conclude that

$$\mathbf{R}^\top \mathbf{R} = \mathbf{C} = \mathbf{I} \quad (4.22)$$

Interestingly, not all matrices \mathbf{R} satisfying Equation 4.22 represent motions in three-dimensional space.

Consider, e.g., matrix

$$\mathbf{S} = \begin{bmatrix} 1 & 0 & 0 \\ 0 & 1 & 0 \\ 0 & 0 & -1 \end{bmatrix} \quad (4.23)$$

Matrix \mathbf{S} does not correspond to any rotation of the space since it keeps the plane xy fixed and reflects all other points w.r.t. this xy plane. We see that some matrices satisfying Equation 4.22 are rotations but there are also some such matrices that are not rotations. Can we somehow distinguish them?

Notice that $|\mathbf{S}| = -1$ while $|\mathbf{I}| = 1$. It might be therefore interesting to study the determinant of \mathbf{C} in general. Consider that

$$1 = |\mathbf{I}| = |(\mathbf{R}^\top \mathbf{R})| = |\mathbf{R}^\top| |\mathbf{R}| = |\mathbf{R}| |\mathbf{R}| = (|\mathbf{R}|)^2 \quad (4.24)$$

which gives that $|\mathbf{R}| = \pm 1$. We see that the sign of the determinant splits all matrices satisfying Equation 4.22 into two groups – rotations, which have a positive determinant, and reflections, which have a negative determinant. The product of any two rotations will again be a rotation, the product of a rotation and a reflection will be a reflection and the product of two reflections will be a rotation.

To summarize, rotation in three-dimensional space is represented by a 3×3 matrix \mathbf{R} with $\mathbf{R}^\top \mathbf{R} = \mathbf{I}$ and $|\mathbf{R}| = 1$. The set of all such matrices, and at the same time also the corresponding rotations, will be called $SO(3)$, for *special orthonormal three-dimensional group*. Two-dimensional rotations will be analogically denoted as $SO(2)$.

4.3 Coordinate vectors

We see that the matrix \mathbf{R} induced by motion has the property that coordinates and the basic vectors are transformed in the same way. This is particularly useful observation when β is formed by the standard basis, i.e.

$$\beta = \left(\begin{bmatrix} 1 \\ 0 \\ 0 \end{bmatrix}, \begin{bmatrix} 0 \\ 1 \\ 0 \end{bmatrix}, \begin{bmatrix} 0 \\ 0 \\ 1 \end{bmatrix} \right) \quad (4.25)$$

For a rotation matrix \mathbf{R} , Equation 2.15 becomes

$$\begin{bmatrix} \vec{b}'_1 \\ \vec{b}'_2 \\ \vec{b}'_3 \end{bmatrix} = \mathbf{R} \begin{bmatrix} \vec{b}_1 \\ \vec{b}_2 \\ \vec{b}_3 \end{bmatrix} = \begin{bmatrix} r_{11} & r_{12} & r_{13} \\ r_{21} & r_{22} & r_{23} \\ r_{31} & r_{32} & r_{33} \end{bmatrix} \begin{bmatrix} \vec{b}_1 \\ \vec{b}_2 \\ \vec{b}_3 \end{bmatrix} = \begin{bmatrix} r_{11}\vec{b}_1 + r_{12}\vec{b}_2 + r_{13}\vec{b}_3 \\ r_{21}\vec{b}_1 + r_{22}\vec{b}_2 + r_{23}\vec{b}_3 \\ r_{31}\vec{b}_1 + r_{32}\vec{b}_2 + r_{33}\vec{b}_3 \end{bmatrix} \quad (4.26)$$

and hence

$$\vec{b}'_1 = r_{11}\vec{b}_1 + r_{12}\vec{b}_2 + r_{13}\vec{b}_3 = r_{11} \begin{bmatrix} 1 \\ 0 \\ 0 \end{bmatrix} + r_{12} \begin{bmatrix} 0 \\ 1 \\ 0 \end{bmatrix} + r_{13} \begin{bmatrix} 0 \\ 0 \\ 1 \end{bmatrix} = \begin{bmatrix} r_{11} \\ r_{12} \\ r_{13} \end{bmatrix} \quad (4.27)$$

and similarly for \vec{b}'_2 and \vec{b}'_3 . We conclude that

$$\begin{bmatrix} \vec{b}'_1 & \vec{b}'_2 & \vec{b}'_3 \end{bmatrix} = \begin{bmatrix} r_{11} & r_{21} & r_{31} \\ r_{12} & r_{22} & r_{32} \\ r_{13} & r_{23} & r_{33} \end{bmatrix} = \mathbf{R}^\top \quad (4.28)$$

This also corresponds to solving for \mathbf{R} in Equation 2.13 with $\mathbf{A} = \mathbf{R}$

$$\begin{bmatrix} 1 & 0 & 0 \\ 0 & 1 & 0 \\ 0 & 0 & 1 \end{bmatrix} = \begin{bmatrix} \vec{b}'_1 & \vec{b}'_2 & \vec{b}'_3 \end{bmatrix} \mathbf{R} \quad (4.29)$$

5 Image coordinate system

Digital image Im is a matrix of pixels. We assume that Im is obtained by measuring intensity of light by sensors (pixels) arranged in a grid, Figure 5.1.

We will work with images in two ways. First, we will work with intensity values, which are stored in the memory as a three-dimensional array of bytes indexed by the row index i , the column index j , and the color index k , Figure 5(a). Color index attains three values 1, 2, 3, with 1 corresponding to red, 2 corresponding to green and 3 corresponding to blue colors.

In `Matlab`, image Im is accessed using the row index i , the column index j and the color index k as `>>Im(i,j,k)`. The most top left pixel has row as well as column index equal to 1. The red channel of the pixel with row index 2 and column index 3 is accessed as `>>Im(2,3,1)`.

§ 1 Image coordinate system For geometrical computation, we introduce an *image coordinate system* as in Figure 5(b). The origin of the image coordinate system is chosen to assign coordinates 1, 1 to the center of the most top left pixel. Horizontal axis \vec{b}_1 goes from left to right. The vertical axis \vec{b}_2 goes from top down. The pixel that is accessed as `>>Im(i,j,k)` is in the image coordinate system represented by the vector $\vec{u} = [j, i]^\top$. A digital image with H rows and W columns will be indexed in `Matlab` as `>>Im(1:H,1:W,1:3)` and `>>size(Im)` will return $[H \ W \ 3]$. The center of the most bottom right pixel will have coordinates $[W, H]^\top$ in the image coordinate system.

The image coordinate system coincides with the `Matlab` coordinate system `image`, i.e. commands

```
>> axis image
>> plot(j,i,'.b')
```

plot a blue dot on the pixel accessed as `Im(i,j,k)`;

The image coordinate system is non-standard in two dimensions since it is a left-handed system. The reason for such a unnatural choice is that this system will be next augmented into a three-dimensional right-handed coordinate system in such a way that the \vec{b}_3 vector will be pointing towards the scene.

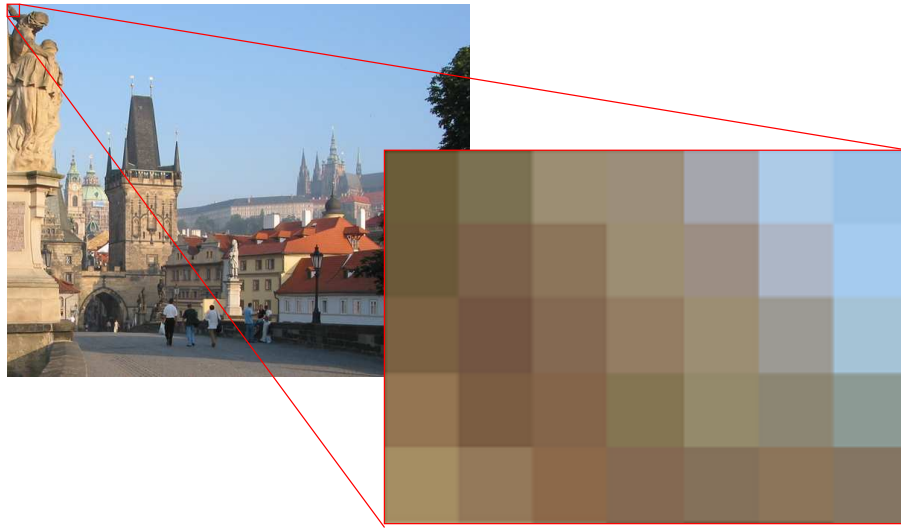
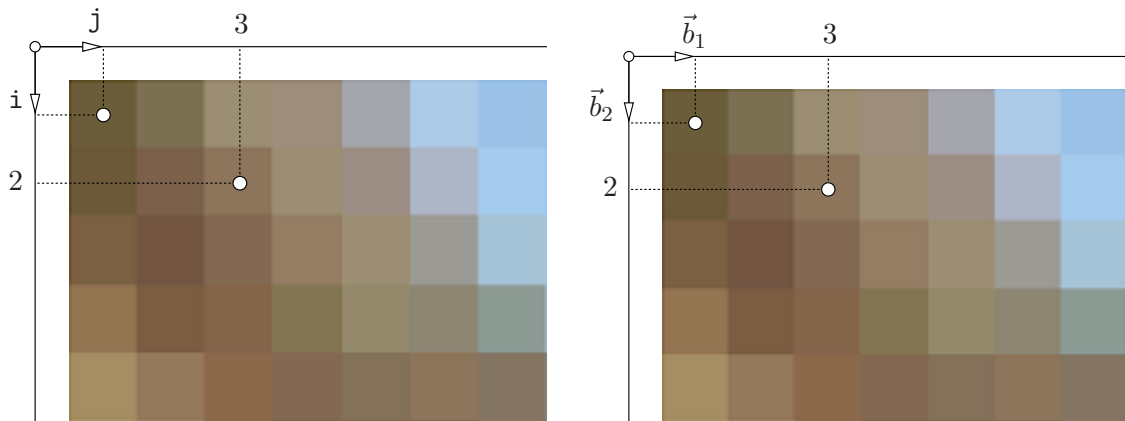

Figure 5.1: Image is digitized by a rectangular array of pixels



(a) Image Im is a matrix of pixels. In Matlab, it is accessed using the row index i , the column index j and color index k as `>>Im(i,j,k)`. The most top left pixel has row as well as column index equal to 1. The red channel of the pixel with row index 2 and column index 3 is accessed as `>>Im(2,3,1)`.

(b) The image coordinate system is defined with horizontal axis \vec{b}_1 and vertical axis \vec{b}_2 . The origin of the coordinate system is chosen to assign coordinates 1, 1 to the most top left pixel. Notice that pixel, which is accessed as `>>Im(2,3,1)`, is represented in the image coordinate system by the vector $\vec{u} = [3, 2]^T$.

Figure 5.2: Image coordinate system.

6 Perspective camera

Modern photographic camera, Figure 6.1, is an interesting and advanced device. We shall abstract from all physical and technical details of image formation and will concentrate solely on its geometry. From the point of view of geometry, a perspective camera projects point X from space into an image point x by intersecting the line connecting X with the *projection center* (red) and a planar image plane (green), Figure 6.1(b).

6.1 Perspective camera model

Let us now develop a mathematical model of the perspective camera. The model will allow us to project space point X into image point x and to find the ray p in space along the which point X has been projected.

§1 Camera coordinate system Figure 6.2 shows the geometry of the perspective camera. Point X is projected along ray p from three-dimensional space to point x into two-dimensional image. Point x is obtained as the intersection of ray p with planar *image plane* π . Ray p is constructed by joining point X with the *projection center* C . The plane through the projection center C , which is parallel to the image plane is called the *principal plane*.

The image plane is equipped with an image coordinate system (§1), (o, α) , where o is the origin and $\alpha = [\vec{b}_1, \vec{b}_2]$ is the basis of the image coordinate system. Notice that the basis α is shown as non-orthogonal. We want to develop a general camera model, which will be applicable even in the situation when image coordinate system is not rectangular. Point x is represented by vector \vec{u} in (o, α)

$$\vec{u} = u \vec{b}_1 + v \vec{b}_2 \quad \text{i.e.} \quad \vec{u}_\alpha = \begin{bmatrix} u \\ v \end{bmatrix} \quad (6.1)$$

Three-dimensional space is equipped with a *world coordinate system* (O, δ) , where O is the origin and $\delta = [\vec{d}_1, \vec{d}_2, \vec{d}_3]$ is a three-dimensional orthonormal basis. Point X is represented by vector \vec{X} in (O, δ) . The camera projection center is represented by vector \vec{C} in (O, δ) .

Let us next define the *camera coordinate system*. The system will be derived from the image coordinate system to make the construction of coordinates of the direction vector \vec{x} of p extremely simple.

Camera coordinate system (C, β) has the origin in the projection center C and its basis $\beta = [\vec{b}_1, \vec{b}_2, \vec{b}_3]$ is constructed by re-using the two basis vectors of α and adding the third basic vector \vec{b}_3 , which corresponds to vector $\vec{C}\vec{o}$. We see that vectors in β form a basis when point C is not in π , which is satisfied for every meaningful perspective camera. Notice also that the camera coordinate system is three-dimensional.

Image points o and x are in plane π , which is in three-dimensional space, and therefore we can consider them as points of that space too. Point x is in (C, β) represented by vector \vec{x} , which is the direction vector of the projection ray p along which point X has been projected into x . We

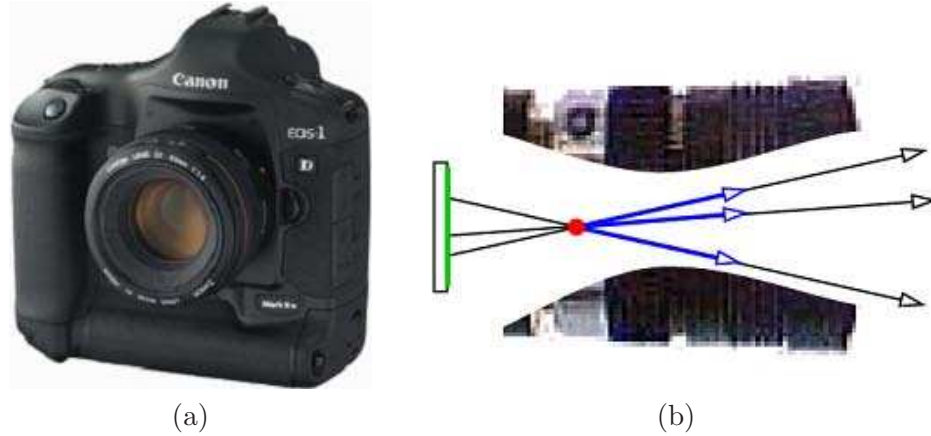

Figure 6.1: Perspective camera (a) is geometrically a point (red) and an image plane (green) (b).

see that vectors \vec{u} , \vec{x} , \vec{b}_3 form a triangle such that

$$\vec{x} = \vec{u} + \vec{b}_3 \quad (6.2)$$

$$= u\vec{b}_1 + v\vec{b}_2 + 1\vec{b}_3 \quad (6.3)$$

and therefore

$$\vec{x}_\beta = \vec{x}_{[\vec{b}_1, \vec{b}_2, \vec{b}_3]} = \begin{bmatrix} u \\ v \\ 1 \end{bmatrix} = \begin{bmatrix} \vec{u}_\alpha \\ 1 \end{bmatrix}. \quad (6.4)$$

Notice that basis β has been constructed in a very special way to facilitate construction of \vec{x}_β . We can use u , v directly since β re-uses vectors of α and the third coordinate is always 1 by the construction of \vec{b}_3 . Although we do not know exact position of C w.r.t. the image plane, we know that it is not in the plane π and hence a meaningful camera coordinate system constructed this way exists.

Notice next that the camera coordinate system is right-handed. This is because when looking at a scene from a point C through the image plane, the image is constructed by intersecting image rays with the image plane, which is in front and hence the vector \vec{b}_3 points towards the scene. We see that vectors of β form a right-handed system.

Let us mention that we have used deeper properties of linear and affine spaces. In particular, we were making use of the concept of *free vector* in the following way. We look at vectors \vec{b}_1 , \vec{b}_2 and \vec{u} as on a free vectors. Therefore, coordinates of the representative of \vec{u} beginning in o with respect to representatives of \vec{b}_1 , \vec{b}_2 beginning in o equal the coordinates of the representative of \vec{u} beginning in C with respect to representatives of \vec{b}_1 , \vec{b}_2 beginning in C . Hence u , v reappear as the first two coordinates of \vec{x} .

For usual consumer cameras, vector \vec{b}_3 is often much longer than vectors \vec{b}_1 , \vec{b}_2 and often not orthogonal to them. Therefore, basis β is in general neither orthonormal nor orthogonal! This has severe consequences since we can't measure angles and distances in the space using β , unless we find out what are the lengths of its vectors and what are the angles between them.

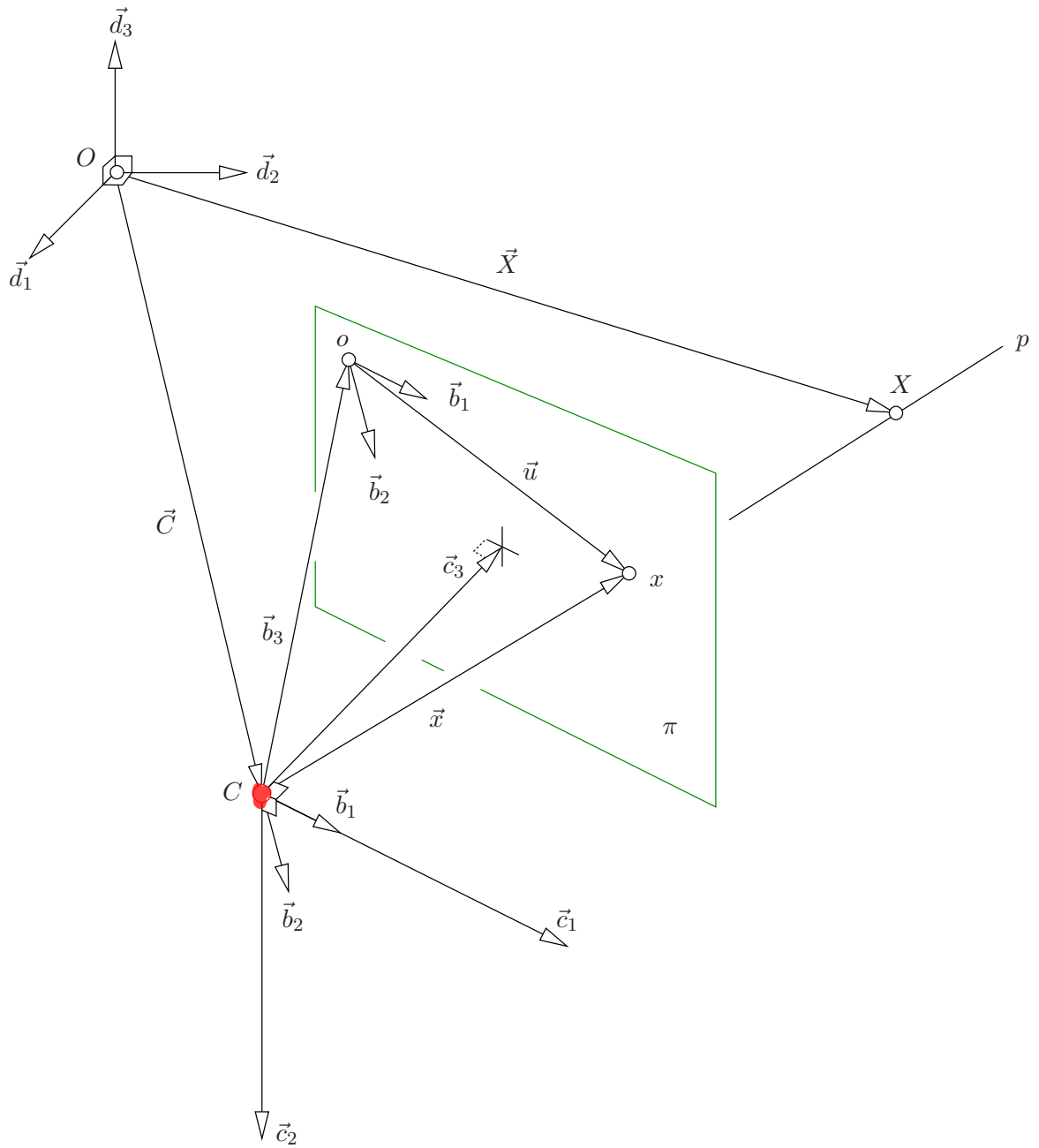

Figure 6.2: Coordinate systems of perspective camera.

§ 2 Perspective projection Point X has been projected along p into x . Since \vec{x} is a direction vector of p , point X can be represented in (C, β) by

$$\eta \vec{x} \tag{6.5}$$

for some real *non-negative*¹ η . The value of η corresponds to the scaled depth of X , i.e. the distance of X from the plane passing through C and generated by \vec{b}_1, \vec{b}_2 in units equal to the distance of C from π . Value η is not known since it “has been lost” in the process of projection² but will serve us to parametrize the projection ray in order to get coordinates of all possible points in space that could project into x .

Let us now relate the coordinates \vec{u}_α , which are measured in the image, to the coordinates \vec{X}_δ , which are measured in the world coordinate system. First consider vectors \vec{X}, \vec{C} and \vec{x} . They are coplanar and we see that there holds

$$\eta \vec{x} = \vec{X} - \vec{C} \tag{6.6}$$

To pass to coordinates, we will use the camera coordinate system, in which we can write

$$\eta \vec{x}_\beta = \vec{X}_\beta - \vec{C}_\beta \tag{6.7}$$

$$\eta \begin{bmatrix} \vec{u}_\alpha \\ 1 \end{bmatrix} = \vec{X}_\beta - \vec{C}_\beta \tag{6.8}$$

Next we shall pass to the coordinates w.r.t. basis δ on the right hand side of Equation 6.8 by introducing a matrix \mathbf{A} , which transforms coordinates of a general vector \vec{y} from basis δ to basis β , i.e.

$$\vec{y}_\beta = \mathbf{A} \vec{y}_\delta \tag{6.9}$$

We know from linear algebra (§ 3) that such a matrix exists. We write

$$\eta \begin{bmatrix} \vec{u}_\alpha \\ 1 \end{bmatrix} = \mathbf{A} (\vec{X}_\delta - \vec{C}_\delta) \tag{6.10}$$

$$\eta \begin{bmatrix} \vec{u}_\alpha \\ 1 \end{bmatrix} = \mathbf{A} \left[\mathbf{I} \mid -\vec{C}_\delta \right] \begin{bmatrix} \vec{X}_\delta \\ 1 \end{bmatrix} \tag{6.10}$$

$$\eta \begin{bmatrix} \vec{u}_\alpha \\ 1 \end{bmatrix} = \mathbf{P}_\beta \begin{bmatrix} \vec{X}_\delta \\ 1 \end{bmatrix} \tag{6.11}$$

$$\eta \vec{x}_\beta = \mathbf{P}_\beta \begin{bmatrix} \vec{X}_\delta \\ 1 \end{bmatrix} \tag{6.12}$$

with 3×4 *image projection matrix*

$$\mathbf{P}_\beta = \left[\mathbf{A} \mid -\mathbf{A} \vec{C}_\delta \right] \tag{6.13}$$

¹Here we choose \vec{x} such that η is non-negative. Considering negative η , as in [15], may be necessary if it is not clear how has the image coordinate systems been defined or how has \vec{x} been chosen. For instance, if \vec{x} has been chosen to point along ray p away from X , η would have to be negative.

²It can be recovered when a point X is observed by two cameras with different projection centers.

§3 Projection equation Equation 6.11 describes the relationship between measurement \vec{u}_α in the image and measurement \vec{X}_δ in space. It says that \vec{X}_δ is projected into \vec{u}_α since there exists η such that Equation 6.11 holds. Notice that η multiple of the vector on the left of Equation 6.11 is obtained by a linear mapping represented by matrix P_β from vector \vec{X}_δ on the right.

When computing \vec{u}_α from \vec{X}_δ , we actually eliminate η using the last row of the (matricidal) equation (6.11)

$$\vec{u}_\alpha = \begin{bmatrix} \frac{\mathbf{p}_1^\top \mathbf{X}}{\mathbf{p}_3^\top \mathbf{X}} \\ \frac{\mathbf{p}_2^\top \mathbf{X}}{\mathbf{p}_3^\top \mathbf{X}} \end{bmatrix} \quad (6.14)$$

where we introduced rows of $\mathbf{p}_1, \mathbf{p}_2, \mathbf{p}_3$ of \mathbf{P} and a 4×1 vector \mathbf{X} as follows

$$\mathbf{P}_\beta = \begin{bmatrix} \mathbf{p}_1^\top \\ \mathbf{p}_2^\top \\ \mathbf{p}_3^\top \end{bmatrix} \quad \text{and} \quad \mathbf{X} = \begin{bmatrix} \vec{X}_\delta \\ 1 \end{bmatrix} \quad (6.15)$$

Notice that the projection equation is not linear. It is a rational function of the first order polynomials in elements of \mathbf{X} .

§4 Projection ray Having an image point \vec{u}_α , we can construct its projection ray p in space. The ray consists of all points \vec{Y} that can project to \vec{u}_α . In (C, β) , the ray is emanating from the origin C . We parametrize it by real η and express it in (O, δ) by vector \vec{X}_δ

$$\begin{aligned} \vec{Y}_\beta &= \eta \begin{bmatrix} \vec{u}_\alpha \\ 1 \end{bmatrix} = \eta \vec{x}_\beta \\ \vec{X}_\delta &= \eta \mathbf{A}^{-1} \vec{x}_\beta + \vec{C}_\delta \end{aligned} \quad (6.16)$$

Notice that \vec{X}_δ (6.16) can also be obtained for a given η by solving the system of linear equations (6.12) for \vec{X}_δ .

6.2 Computing image projection matrix from images of six points

Let us now consider the task of finding the P_β from measurements. We shall consider the situation when we can measure points in space as well as their projection in the image. Consider a pair of such measurements $[x, y, z]^\top \overset{corr}{\leftrightarrow} [u, v]^\top$. There holds

$$\lambda \begin{bmatrix} u \\ v \\ 1 \end{bmatrix} = \mathbf{Q} \begin{bmatrix} x \\ y \\ z \\ 1 \end{bmatrix} = \mathbf{Q} \mathbf{X} \quad (6.17)$$

for some real λ , 3×4 matrix \mathbf{Q} and 4×1 coordinate vector \mathbf{X} . Notice that we introduced new symbols λ and \mathbf{Q} to emphasize that they are determined by Equation 6.17 up to a non-zero scale

$$\mathbf{Q} = \xi \mathbf{P}_\beta \quad (6.18)$$

We will see that this will have further consequences.

Introduce symbols for rows of \mathbf{Q}

$$\mathbf{Q} = \begin{bmatrix} \mathbf{q}_1^\top \\ \mathbf{q}_2^\top \\ \mathbf{q}_3^\top \end{bmatrix} \quad (6.19)$$

and rewrite the above matrix equation as

$$\lambda u = \mathbf{q}_1^\top \mathbf{X} \quad (6.20)$$

$$\lambda v = \mathbf{q}_2^\top \mathbf{X} \quad (6.21)$$

$$\lambda = \mathbf{q}_3^\top \mathbf{X} \quad (6.22)$$

Eliminate λ from the first two equations using the third one

$$(\mathbf{q}_3^\top \mathbf{X}) u = \mathbf{q}_1^\top \mathbf{X} \quad (6.23)$$

$$(\mathbf{q}_3^\top \mathbf{X}) v = \mathbf{q}_2^\top \mathbf{X} \quad (6.24)$$

move all to the left hand side and reshape it using $\mathbf{x}^\top \mathbf{y} = \mathbf{y}^\top \mathbf{x}$

$$\mathbf{X}^\top \mathbf{q}_1 - (u \mathbf{X}^\top) \mathbf{q}_3 = 0 \quad (6.25)$$

$$\mathbf{X}^\top \mathbf{q}_2 - (v \mathbf{X}^\top) \mathbf{q}_3 = 0 \quad (6.26)$$

Introduce vector of parameters (which are elements of \mathbf{Q})

$$\mathbf{q} = [\mathbf{q}_1^\top \quad \mathbf{q}_2^\top \quad \mathbf{q}_3^\top]^\top \quad (6.27)$$

and express the above two equations in matrix form

$$\begin{bmatrix} x & y & z & 1 & 0 & 0 & 0 & 0 & -ux & -uy & -uz & -u \\ 0 & 0 & 0 & 0 & x & y & z & 1 & -vx & -vy & -vz & -v \end{bmatrix} \mathbf{q} = 0$$

$$\mathbf{M} \mathbf{q} = 0 \quad (6.28)$$

Every correspondence $[x, y, z]^\top \overset{corr}{\leftrightarrow} [u, v]^\top$ brings two rows into the matrix \mathbf{M} (6.28). We need therefore at least 6 correspondences in general position to obtain 11 linearly independent rows in Equation 6.28 to obtain a one-dimensional space of solutions.

If \mathbf{Q} is a solution to Equation 6.28, then $\tau \mathbf{Q}$ is also a solution and both determine the same projection for any positive τ since

$$(\tau \mathbf{Q}) \mathbf{X} = \tau (\mathbf{Q} \mathbf{X}) = \tau (\lambda \vec{x}_\beta) = (\tau \lambda) \vec{x}_\beta \quad (6.29)$$

Assuming $\mathbf{P}_\beta = \tau \mathbf{Q}$ leads to $\lambda = \eta/\tau$. We see that we can't recover \mathbf{P}_β but only its non-zero multiple. Therefore, when solving Equation 6.28, we are looking for one-dimensional subspace of 3×4 matrices of *rank* 3. Such a subspace determines one projection. Also note that the zero matrix does not represent any interesting projection.

Notice that when considering more correspondences, \mathbf{M} becomes

$$\mathbf{M} \mathbf{q} = \begin{bmatrix} x_1 & y_1 & z_1 & 1 & 0 & 0 & 0 & 0 & -u_1 x_1 & -u_1 y_1 & -u_1 z_1 & -u_1 \\ x_2 & y_2 & z_2 & 1 & 0 & 0 & 0 & 0 & -u_2 x_2 & -u_2 y_2 & -u_2 z_2 & -u_2 \\ & & & & & & & & & & & \vdots \\ 0 & 0 & 0 & 0 & x_1 & y_1 & z_1 & 1 & -v_1 x_1 & -v_1 y_1 & -v_1 z_1 & -v_1 \\ 0 & 0 & 0 & 0 & x_2 & y_2 & z_2 & 1 & -v_2 x_2 & -v_2 y_2 & -v_2 z_2 & -v_2 \\ & & & & & & & & & & & \vdots \end{bmatrix} \mathbf{q} = 0 \quad (6.30)$$

Matrix \mathbf{M} can be more concisely rewritten as

$$\mathbf{M} = \begin{bmatrix} \mathbf{X}_1^\top & \mathbf{0}^\top & -u_1 \mathbf{X}_1^\top \\ \mathbf{X}_2^\top & \mathbf{0}^\top & -u_2 \mathbf{X}_2^\top \\ \vdots & \vdots & \vdots \\ \mathbf{0}^\top & \mathbf{X}_1^\top & -v_1 \mathbf{X}_1^\top \\ \mathbf{0}^\top & \mathbf{X}_2^\top & -v_2 \mathbf{X}_2^\top \\ \vdots & \vdots & \vdots \end{bmatrix} \quad (6.31)$$

with $\mathbf{0}^\top = [0, 0, 0, 0]$.

§ 1 A more general procedure for computing \mathbf{Q} We shall next develop an alternative formulation for finding matrix \mathbf{Q} . Let us come back to Equation 6.17

$$\lambda \vec{u} = \mathbf{Q} \mathbf{X} \quad (6.32)$$

Above, we have eliminated λ assuming $\vec{u}_3 = 1$. Let us now present an alternative procedure for eliminating λ , which works for any non-zero $\vec{u} = [u, v, w]^\top$, i.e. even when $w = 0$. The trick is to realize that

$$0 = \vec{u} \times (\lambda \vec{u}) = \vec{u} \times \mathbf{Q} \mathbf{X} = [\vec{u}]_\times \mathbf{Q} \mathbf{X} \quad (6.33)$$

This gives three equations for each $\vec{u} \leftrightarrow \mathbf{X}$ correspondence. However, only two of them are linearly independent since $[\vec{u}]_\times$ has rank two. Now, we are in the position to employ Equation 2.90, which gives

$$[\vec{u}]_\times \mathbf{Q} \mathbf{X} = \mathbf{0} \quad (6.34)$$

$$\mathbf{X}^\top \mathbf{Q}^\top [\vec{u}]_\times^\top = \mathbf{0}^\top \quad (6.35)$$

$$v(\mathbf{X}^\top \mathbf{Q}^\top [\vec{u}]_\times^\top) = v(\mathbf{0}^\top) \quad (6.36)$$

$$([\vec{u}]_\times \otimes \mathbf{X}^\top) v(\mathbf{Q}^\top) = v(\mathbf{0}^\top) \quad (6.37)$$

$$\left(\begin{bmatrix} 0 & -w & v \\ w & 0 & -u \\ -v & u & 0 \end{bmatrix} \otimes \mathbf{X}^\top \right) v(\mathbf{Q}^\top) = v(\mathbf{0}^\top) \quad (6.38)$$

$$\begin{bmatrix} \mathbf{0}^\top & -w \mathbf{X}^\top & v \mathbf{X}^\top \\ w \mathbf{X}^\top & \mathbf{0}^\top & -u \mathbf{X}^\top \\ -v \mathbf{X}^\top & u \mathbf{X}^\top & \mathbf{0}^\top \end{bmatrix} v(\mathbf{Q}^\top) = v(\mathbf{0}^\top) \quad (6.39)$$

For more correspondences numbered by i , we then get

$$\begin{bmatrix}
 0^\top & -w_1 \mathbf{X}_1^\top & v_1 \mathbf{X}_1^\top \\
 0^\top & -w_2 \mathbf{X}_2^\top & v_2 \mathbf{X}_2^\top \\
 \vdots & \vdots & \vdots \\
 w_1 \mathbf{X}_1^\top & 0^\top & -u_1 \mathbf{X}_1^\top \\
 w_2 \mathbf{X}_2^\top & 0^\top & -u_2 \mathbf{X}_2^\top \\
 \vdots & \vdots & \vdots \\
 -v_1 \mathbf{X}_1^\top & u_1 \mathbf{X}_1^\top & 0^\top \\
 -v_2 \mathbf{X}_2^\top & u_2 \mathbf{X}_2^\top & 0^\top \\
 \vdots & \vdots & \vdots
 \end{bmatrix} v(\mathbf{Q}^\top) = 0 \tag{6.40}$$

which if, for $w = 1$, is equivalent to Equation 6.30. Notice that $v(\mathbf{Q}^\top) = \mathbf{q}$ from Equation 6.30.

7 Camera calibration

Let us now look at a useful interpretation of image projection matrix in space and image equipped with a cartesian coordinate systems.

7.1 Camera pose

The projection formula 6.10 reveals that the perspective projection depends on matrix \mathbf{A} and vector \vec{C}_δ . The vector \vec{C}_δ represents the position of the camera projection center w.r.t. the world coordinate system. Columns of matrix \mathbf{A} are coordinates of the basic vectors of δ in the basis β

$$\mathbf{A} = \begin{bmatrix} \vec{d}_{1_\beta} & \vec{d}_{2_\beta} & \vec{d}_{3_\beta} \end{bmatrix} \quad (7.1)$$

To recover the orientation of the camera, we will introduce the focal length f as the distance of the camera projection center C from its projection plane π (in the world units) and replace the product $f \mathbf{A}$ by the product of two 3×3 matrices \mathbf{K} and \mathbf{R}

$$f \mathbf{A} = \mathbf{K} \mathbf{R} \quad (7.2)$$

We will see that this seemingly artificial construction is indeed justified.

Rotation matrix \mathbf{R} determines the orientation of the camera in space and altogether with \vec{C}_δ defines the *camera pose*. The *camera calibration matrix* \mathbf{K} does not change when moving its camera in the space.

To obtain \mathbf{K} and \mathbf{R} , we define, Figure 7.1, the *camera cartesian coordinate system* (C, γ) with center (again) in the camera projection center C and with basis $\gamma = [\vec{c}_1, \vec{c}_2, \vec{c}_3]$ such that

$$\begin{aligned} \vec{c}_1 &= k_{11} \vec{b}_1 \\ \vec{c}_2 &= k_{12} \vec{b}_1 + k_{22} \vec{b}_2 \\ \vec{c}_3 &= k_{13} \vec{b}_1 + k_{23} \vec{b}_2 + 1 \vec{b}_3 \end{aligned} \quad (7.3)$$

Parameters k_{ij} are determined to make the basis γ orthogonal. Notice that vector \vec{c}_3 is orthogonal to π since it is orthogonal to \vec{c}_1, \vec{c}_2 , which span π , by construction. Also notice that γ is (in general) not an orthonormal basis since the length of its vectors equals the distance of C from π , i.e. the *focal length* f in the world units.

Equations 7.3 define matrix \mathbf{K} as

$$\mathbf{K} = \begin{bmatrix} \vec{c}_{1_\beta} & \vec{c}_{2_\beta} & \vec{c}_{3_\beta} \end{bmatrix} = \begin{bmatrix} k_{11} & k_{12} & k_{13} \\ 0 & k_{22} & k_{23} \\ 0 & 0 & 1 \end{bmatrix} \quad (7.4)$$

By this construction, we have

$$\vec{x}_\beta = \mathbf{A} \vec{x}_\delta = \mathbf{K} \vec{x}_\gamma \quad (7.5)$$

$$\vec{x}_\gamma = = \frac{1}{f} \mathbf{R} \vec{x}_\delta \quad (7.6)$$

The world cartesian coordinate system has basic vectors of unit length. The camera cartesian coordinate system (C, γ) has basic vectors of length equal to f . Therefore,

$$\begin{bmatrix} \vec{d}_{1\gamma} & \vec{d}_{2\gamma} & \vec{d}_{3\gamma} \end{bmatrix} = \frac{1}{f} \mathbf{R} = \begin{bmatrix} \mathbf{r}_1^\top / f \\ \mathbf{r}_2^\top / f \\ \mathbf{r}_3^\top / f \end{bmatrix} \quad (7.7)$$

for some 3×3 orthonormal matrix \mathbf{R} with rows $\mathbf{r}_1^\top, \mathbf{r}_2^\top, \mathbf{r}_3^\top$.

Consider that

$$\mathbf{A} = \begin{bmatrix} \vec{d}_{1\beta} & \vec{d}_{2\beta} & \vec{d}_{3\beta} \end{bmatrix} = \mathbf{K} \begin{bmatrix} \vec{d}_{1\gamma} & \vec{d}_{2\gamma} & \vec{d}_{3\gamma} \end{bmatrix} = \frac{1}{f} \mathbf{K} \mathbf{R} \quad (7.8)$$

We can view the matrices $\frac{1}{f} \mathbf{R}$ and \mathbf{K} as coordinate transformation matrices, which transform a general vector \vec{y} from the coordinates w.r.t. δ to γ and then to β , i.e.

$$\vec{y}_\beta = \mathbf{K} \vec{y}_\gamma = \frac{1}{f} \mathbf{K} \mathbf{R} \vec{y}_\delta \quad (7.9)$$

The basis γ is orthogonal and all basic vectors have the same length, which is equal to f . It follows from the orthogonality of the basis γ that $\vec{c}_1 \cdot \vec{c}_1 = f^2$, $\vec{c}_1 \cdot \vec{c}_2 = 0$ and $\vec{c}_2 \cdot \vec{c}_2 = f^2$ and hence using Equation 7.3 leads, for a positive f , to

$$\begin{aligned} k_{11} \|\vec{b}_1\| - f &= 0 \\ k_{11}^2 k_{22} (\vec{b}_1 \cdot \vec{b}_2) + k_{12} f^2 &= 0 \\ k_{11}^2 k_{22}^2 \|\vec{b}_2\|^2 - (k_{12}^2 + k_{11}^2) f^2 &= 0 \end{aligned} \quad (7.10)$$

Let us solve Equations 7.10 for k_{11} , k_{12} and k_{22} . The first equation in (7.10) provides k_{11} . Substituting the square of f from the first equation into the second one and dividing it by k_{11}^2 gives the second equation of (7.11), which allows to compute k_{12} from k_{22} . To get k_{22} , we construct the third equation of (7.11) as follows. We express k_{11} from the first equation of (7.10) and k_{12} from the second equation of (7.11) and substitute them into the third equation of (7.10), which we then multiply by $\|\vec{b}_1\|^4 / f^2$. Altogether, we get

$$\begin{aligned} k_{11} \|\vec{b}_1\| - f &= 0 \\ k_{12} \|\vec{b}_1\|^2 + k_{22} (\vec{b}_1 \cdot \vec{b}_2) &= 0 \\ k_{22}^2 (\|\vec{b}_1\|^2 \|\vec{b}_2\|^2 - (\vec{b}_1 \cdot \vec{b}_2)^2) - f^2 \|\vec{b}_1\|^2 &= 0 \end{aligned} \quad (7.11)$$

Looking at the third equation of (7.11) we see that

$$k_{22}^2 = \frac{f^2 \|\vec{b}_1\|^2}{\|\vec{b}_1\|^2 \|\vec{b}_2\|^2 - (\vec{b}_1 \cdot \vec{b}_2)^2} = \frac{f^2}{\|\vec{b}_2\|^2 - \|\vec{b}_2\|^2 \cos^2 \angle(\vec{b}_1, \vec{b}_2)} \quad (7.12)$$

and since γ was constructed to make k_{22} positive, we obtain

$$k_{22} = \frac{f}{\|\vec{b}_2\| \sin \angle(\vec{b}_1, \vec{b}_2)} \quad (7.13)$$

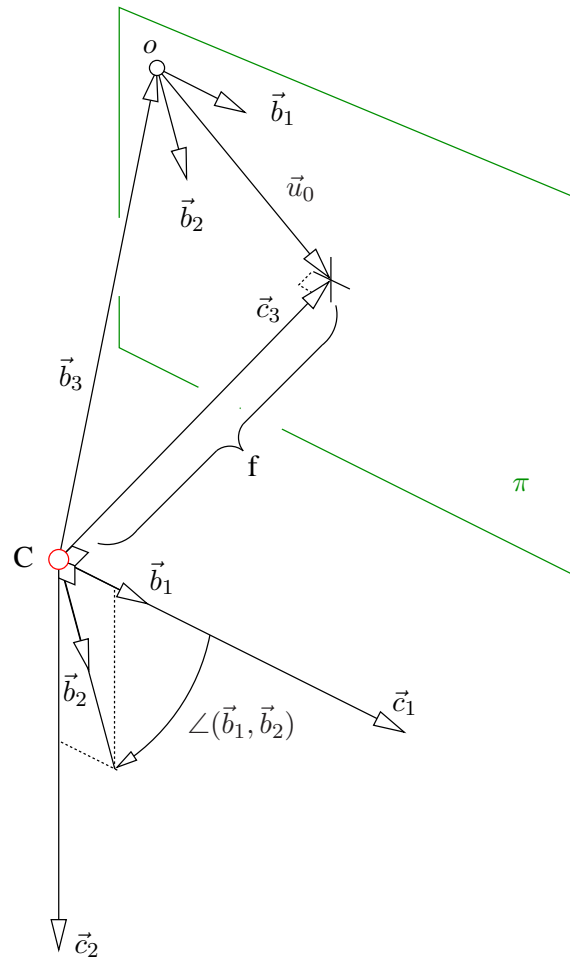

Figure 7.1: Camera internal parameters are related to the geometry of basis β .

The second equation of (7.10) now gives

$$k_{12} = -k_{22} \frac{\vec{b}_1 \cdot \vec{b}_2}{\|\vec{b}_1\|^2} = -k_{22} \frac{\|\vec{b}_2\| \cos \angle(\vec{b}_1, \vec{b}_2)}{\|\vec{b}_1\|} \quad (7.14)$$

$$= -\frac{f \cos \angle(\vec{b}_1, \vec{b}_2)}{\|\vec{b}_1\| \sin \angle(\vec{b}_1, \vec{b}_2)} \quad (7.15)$$

Finally k_{11} follows from (7.11)

$$k_{11} = \frac{f}{\|\vec{b}_1\|} \quad (7.16)$$

Considering Figure 7.1 and Equation 7.3, we see that the coordinates of the vector \vec{u}_0 , corresponding to the *principal point*, which is the perpendicular projection of C onto π , are in β

$$\vec{u}_{0\beta} = \begin{bmatrix} k_{13} \\ k_{23} \\ 0 \end{bmatrix}, \text{ i.e. } \vec{u}_{0\alpha} = \begin{bmatrix} k_{13} \\ k_{23} \end{bmatrix} \quad (7.17)$$

The horizontal pixel size corresponds to $\|\vec{b}_1\|$. Quantity k_{11} can thus be understood as f expressed in the horizontal image units. The angle between the image axes \vec{b}_1, \vec{b}_2 is obtained from $k_{12}/k_{11} = -\cotan \angle(\vec{b}_1, \vec{b}_2)$. The ratio of the lengths of the image axes is determined by $\|\vec{b}_2\|/\|\vec{b}_1\| = \sqrt{k_{11}(k_{11}^2 + k_{12}^2)}/k_{22}$.

Let us now return to Equation 6.11 and substitute there the above results to arrive at the final projection equation

$$\eta \vec{x}_\beta = \mathbb{P}_\beta \begin{bmatrix} \vec{X}_\delta \\ 1 \end{bmatrix} \quad (7.18)$$

$$\eta \begin{bmatrix} \vec{u}_\alpha \\ 1 \end{bmatrix} = \mathbf{A} (\vec{X}_\delta - \vec{C}_\delta) \quad (7.19)$$

$$f \eta \begin{bmatrix} \vec{u}_\alpha \\ 1 \end{bmatrix} = f \mathbf{A} (\vec{X}_\delta - \vec{C}_\delta) \quad (7.20)$$

$$f \eta \begin{bmatrix} \vec{u}_\alpha \\ 1 \end{bmatrix} = \mathbf{KR} (\vec{X}_\delta - \vec{C}_\delta) \quad (7.21)$$

$$\zeta \begin{bmatrix} \vec{u}_\alpha \\ 1 \end{bmatrix} = \mathbf{KR} (\vec{X}_\delta - \vec{C}_\delta) \quad (7.22)$$

$$\zeta \begin{bmatrix} \vec{u}_\alpha \\ 1 \end{bmatrix} = \mathbf{KR} [\mathbf{I} | -\vec{C}_\delta] \begin{bmatrix} \vec{X}_\delta \\ 1 \end{bmatrix} \quad (7.23)$$

We have introduced a new parameter $\zeta = f \eta$, which is the depth of X in the world units. We conclude that

$$\mathbb{P}_\beta = \left[\frac{1}{f} \mathbf{KR} | -\frac{1}{f} \mathbf{KR} \vec{C}_\delta \right] \quad (7.24)$$

Notice that the last row \mathbf{a}_3^\top of \mathbf{A} provides f since

$$\mathbf{A} = \begin{bmatrix} \mathbf{a}_1^\top \\ \mathbf{a}_2^\top \\ \mathbf{a}_3^\top \end{bmatrix} = \frac{1}{f} \begin{bmatrix} k_{11} & k_{12} & k_{13} \\ 0 & k_{22} & k_{23} \\ 0 & 0 & 1 \end{bmatrix} \begin{bmatrix} \mathbf{r}_1^\top \\ \mathbf{r}_2^\top \\ \mathbf{r}_3^\top \end{bmatrix} = \frac{1}{f} \begin{bmatrix} k_{11}\mathbf{r}_1^\top + k_{12}\mathbf{r}_2^\top + k_{13}\mathbf{r}_3^\top \\ k_{22}\mathbf{r}_2^\top + k_{23}\mathbf{r}_3^\top \\ \mathbf{r}_3^\top \end{bmatrix} \quad (7.25)$$

and hence $\|\mathbf{a}_3^\top\| = \frac{1}{f}$. Therefore $\|\mathbb{P}_\beta(3, 1 : 3)\| = \frac{1}{f}$.

Equation 7.23 is very important in many practical situations when we do not have access to physical dimensions of the camera but only to images. Then, it is possible to recover matrix $\mathbb{K}\mathbb{R} \left[\mathbb{I} \mid -\vec{C}_\delta \right]$ but not image projection matrix \mathbb{P}_β . This is so important that we introduce the *camera projection matrix*

$$\mathbb{P} = \left[\mathbb{K}\mathbb{R} \mid -\mathbb{K}\mathbb{R}\vec{C}_\delta \right] \quad (7.26)$$

which is related to the image projection matrix as

$$\mathbb{P} = f\mathbb{P}_\beta \quad (7.27)$$

In this text, it would be more consistent to associate subscript ν with the camera projection matrix but we will not do that since we want to use the nomenclature of [15] here whenever possible.

Let us write \mathbb{K} explicitly,

$$\mathbb{K} = \begin{bmatrix} \frac{f}{\|\vec{b}_1\|} & -\frac{f \cos \angle(\vec{b}_1, \vec{b}_2)}{\|\vec{b}_1\| \sin \angle(\vec{b}_1, \vec{b}_2)} & u_0 \\ 0 & \frac{f}{\|\vec{b}_2\| \sin \angle(\vec{b}_1, \vec{b}_2)} & v_0 \\ 0 & 0 & 1 \end{bmatrix} \quad (7.28)$$

where $\vec{u}_{0\alpha} = [u_0 \ v_0]^\top$. We see that we can neither recover f nor $\|\vec{b}_1\|$ from \mathbb{P} .

Let us introduce *image calibration matrix*

$$\mathbb{K}_\beta = \frac{1}{f} \mathbb{K} \quad (7.29)$$

to have

$$\mathbb{P}_\beta = \left[\mathbb{K}_\beta \mathbb{R} \mid -\mathbb{K}_\beta \mathbb{R} \vec{C}_\delta \right] \quad (7.30)$$

Writing image calibration matrix \mathbb{K}_β explicitly,

$$\mathbb{K}_\beta = \frac{1}{f} \mathbb{K} = \begin{bmatrix} \frac{1}{\|\vec{b}_1\|} & -\frac{\cos \angle(\vec{b}_1, \vec{b}_2)}{\|\vec{b}_1\| \sin \angle(\vec{b}_1, \vec{b}_2)} & \frac{u_0}{f} \\ 0 & \frac{1}{\|\vec{b}_2\| \sin \angle(\vec{b}_1, \vec{b}_2)} & \frac{v_0}{f} \\ 0 & 0 & \frac{1}{f} \end{bmatrix} \quad (7.31)$$

shows that it is possible to recover both

$$\|\vec{b}_1\| = \frac{1}{\mathbb{K}_{\beta 11}} \quad \text{and} \quad f = \frac{1}{\mathbb{K}_{\beta 33}} \quad (7.32)$$

from image calibration matrix.

There is an important difference between \mathbb{K}_β and \mathbb{K} regarding the representation of internal camera calibration information. Image calibration matrix \mathbb{K}_β , and also image projection matrix \mathbb{P}_β , captures all calibration information about a perspective image whereas camera calibration matrix \mathbb{K} , and also camera projection matrix \mathbb{P} , captures only the calibration information that can be recovered by auto-calibration from images as we will see later. When the focal length is known in world units or when pixel sizes are known in world units, it is more appropriate to use image calibration \mathbb{K}_β , or image projection matrix \mathbb{P}_β , to represent full internal calibration information.

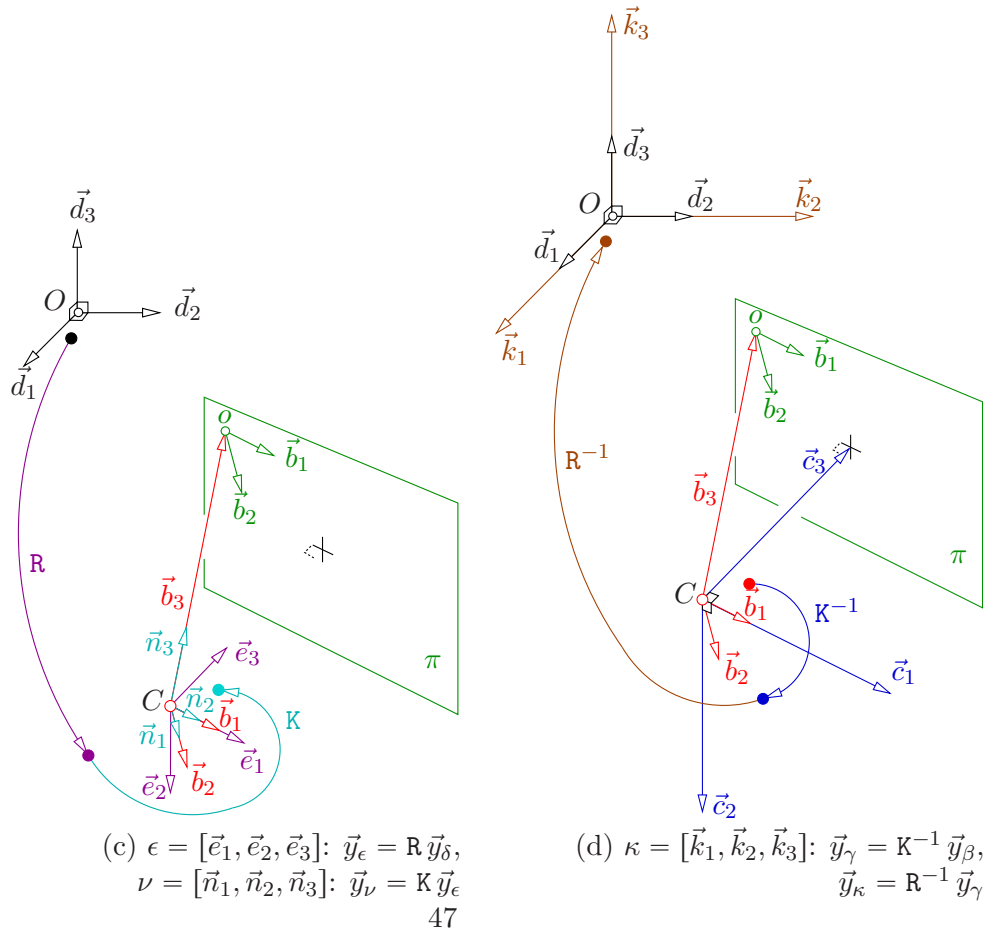
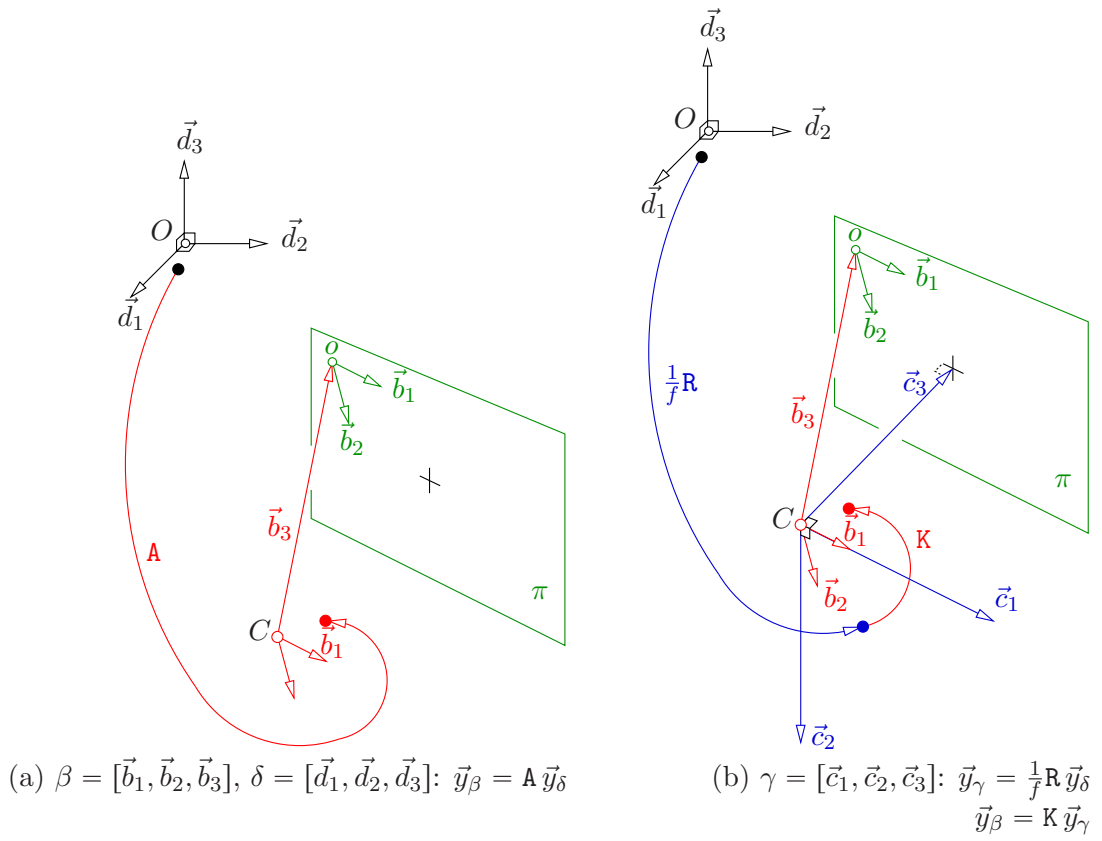

Figure 7.2: Coordinate systems generated by applying $\frac{1}{f} \mathbf{R}$, \mathbf{K} , \mathbf{R} , \mathbf{R}^{-1} and \mathbf{K}^{-1} .

§ 1 Coordinate systems generated by applying KR to \vec{y}_δ and $R^{-1}K^{-1}$ to \vec{y}_β We have seen that the decomposition of A to K and R introduced the camera cartesian coordinate system (C, γ) , Figure 7.2(b)

$$\vec{y}_\gamma = \frac{1}{f}R\vec{y}_\delta \quad (7.33)$$

$$\vec{y}_\beta = K\vec{y}_\gamma \quad (7.34)$$

There are three more coordinate systems to consider when looking at how matrices R, K, and their inverses R^{-1} , K^{-1} , apply to vectors \vec{y}_δ and \vec{y}_β , Figure 7.2.

Let us first consider coordinates of a vector \vec{y} w.r.t. basis δ and apply successively R and K. Coordinate vector $R\vec{y}_\delta$ can be interpreted as coordinates of \vec{y} w.r.t. a new basis $\epsilon = [\vec{e}_1, \vec{e}_2, \vec{e}_3]$, Figure 7.2(c). Applying further K to \vec{y}_ϵ gives the coordinate vector $K\vec{y}_\epsilon$, which can be interpreted as \vec{y} w.r.t. yet another new basis $\nu = [\vec{n}_1, \vec{n}_2, \vec{n}_3]$. We get from ν to β by using $\frac{1}{f}I$

$$\vec{y}_\epsilon = R\vec{y}_\delta \quad (7.35)$$

$$\vec{y}_\nu = K\vec{y}_\epsilon \quad (7.36)$$

$$\vec{y}_\beta = \frac{1}{f}I\vec{y}_\nu \quad (7.37)$$

We have introduced two new coordinate systems (C, ν) , $\nu = [\vec{n}_1, \vec{n}_2, \vec{n}_3]$ and (C, ϵ) , $\epsilon = [\vec{e}_1, \vec{e}_2, \vec{e}_3]$.

Next we consider coordinates of a vector \vec{y} w.r.t. basis β and apply successively K^{-1} and R^{-1} . Coordinate vector $K^{-1}\vec{y}_\beta$ gives \vec{y}_γ . Coordinate vector $R^{-1}\vec{y}_\gamma$ can be interpreted as coordinates of \vec{y} w.r.t. a new basis $\kappa = [\vec{k}_1, \vec{k}_2, \vec{k}_3]$, Figure 7.2(d). To get from \vec{y}_κ to \vec{y}_δ we need to employ fI

$$\vec{y}_\gamma = K^{-1}\vec{y}_\beta \quad (7.38)$$

$$\vec{y}_\kappa = R^{-1}\vec{y}_\gamma \quad (7.39)$$

$$\vec{y}_\delta = fI\vec{y}_\kappa \quad (7.40)$$

We have thus introduced a new coordinate system (O, κ) , $\kappa = [\vec{k}_1, \vec{k}_2, \vec{k}_3]$.

Figure 7.3 summarizes the relationship between coordinates of a vector and between bases associated with a perspective camera.

We can now see why we have chosen to denote the image projection matrix as P_β and the camera projection matrix as P. The image projection matrix provides the ray direction vector \vec{x} in basis β while the camera projection matrix provides the ray direction vector \vec{x} in basis ν .

§ 2 Recovering camera pose from its projection matrix Let us next consider that we have already computed the camera projection matrix

$$Q = \xi P = \xi KR[I | -\vec{C}_\delta] \quad (7.41)$$

consisting of a 3×3 matrix M and 3×1 vector m

$$Q = [M | m] \quad (7.42)$$

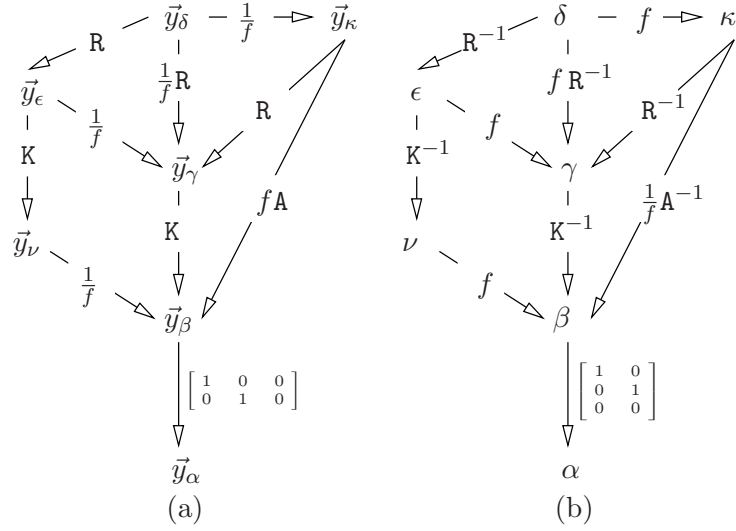

Figure 7.3: Relationships between (a) coordinates in different bases. e.g. $\vec{y}_\beta = \mathbf{K}\vec{y}_\gamma$ and (b) bases themselves, e.g. $\beta = \gamma\mathbf{K}^{-1}$, associated with a perspective camera.

To recover camera pose from \mathbf{Q} , we need to get \vec{C}_δ from \mathbf{m} and to decompose \mathbf{Q} into the product of \mathbf{K} in the form of (7.4) and \mathbf{R} such that $\mathbf{R}^\top\mathbf{R} = \mathbf{I}$ and $|\mathbf{R}| = 1$. Consider \mathbf{M} in the form

$$\mathbf{M} = \begin{bmatrix} \mathbf{m}_1^\top \\ \mathbf{m}_2^\top \\ \mathbf{m}_3^\top \end{bmatrix} \quad (7.43)$$

Next we notice that the last row of $\mathbf{K}\mathbf{R}$ has unit norm since it is equal to the last row of rotation \mathbf{R} . Therefore, we need to divide \mathbf{M} by the norm of its last row to get a matrix decomposable into the product of $\mathbf{K}\mathbf{R}$. Moreover, it follows from the construction of β that $k_{11} > 0$ and $k_{22} > 0$. Thus, determinant $|\mathbf{K}\mathbf{R}| = |\mathbf{K}||\mathbf{R}| = k_{11}k_{22} > 0$. Therefore, we also need to multiply \mathbf{M} by the sign of its determinant to get a matrix decomposable into $\mathbf{K}\mathbf{R}$.

$$\frac{\text{sign } |\mathbf{M}|}{\|\mathbf{m}_3\|} \mathbf{M} = \frac{\text{sign } |\mathbf{M}|}{\|\mathbf{m}_3\|} \begin{bmatrix} \mathbf{m}_1^\top \\ \mathbf{m}_2^\top \\ \mathbf{m}_3^\top \end{bmatrix} = \begin{bmatrix} k_{11} & k_{12} & k_{13} \\ 0 & k_{22} & k_{23} \\ 0 & 0 & 1 \end{bmatrix} \begin{bmatrix} \mathbf{r}_1^\top \\ \mathbf{r}_2^\top \\ \mathbf{r}_3^\top \end{bmatrix} \quad (7.44)$$

which provides the following set of equations

$$\frac{\mathbf{m}_2^\top \mathbf{m}_3}{\|\mathbf{m}_3\|^2} = k_{22} \mathbf{r}_2^\top \mathbf{r}_3 + k_{23} \mathbf{r}_3^\top \mathbf{r}_3 = k_{23} \quad (7.45)$$

$$\frac{\mathbf{m}_1^\top \mathbf{m}_3}{\|\mathbf{m}_3\|^2} = k_{13} \quad (7.46)$$

$$\frac{\mathbf{m}_2^\top \mathbf{m}_2}{\|\mathbf{m}_3\|^2} = k_{22}^2 + k_{23}^2 \quad (7.47)$$

$$\frac{\mathbf{m}_1^\top \mathbf{m}_2}{\|\mathbf{m}_3\|^2} = k_{12} k_{22} + k_{13} k_{23} \quad (7.48)$$

$$\frac{\mathbf{m}_1^\top \mathbf{m}_1}{\|\mathbf{m}_3\|^2} = k_{11}^2 + k_{12}^2 + k_{13}^2 \quad (7.49)$$

from which k_{11} , k_{12} , k_{13} , k_{22} , k_{23} can be easily computed considering that the most of consumer digital cameras have $k_{11} > 0$, $k_{22} > 0$, $k_{13} > 0$, $k_{23} > 0$.

Having k_{ij} computed, we recover \mathbf{R} from \mathbf{M} as

$$\mathbf{R} = \mathbf{K}^{-1} \frac{\text{sign} \|\mathbf{M}\|}{\|\mathbf{m}_3\|} \mathbf{M} \quad (7.50)$$

Camera projection center can be computed in two ways. Either we get

$$\vec{\mathbf{C}}_\delta = -\mathbf{M}^{-1} \mathbf{m} \quad (7.51)$$

or we obtain it by finding a basis \mathbf{c} of the one-dimensional right null space of matrix \mathbf{Q} , i.e. solving

$$\mathbf{Q} \mathbf{c} = 0 \quad (7.52)$$

and then computing

$$\begin{bmatrix} \vec{\mathbf{C}}_\delta \\ 1 \end{bmatrix} = \frac{1}{c_4} \mathbf{c} \quad (7.53)$$

where c_4 is the fourth coordinate of vector \mathbf{c} .

7.2 Camera calibration and angle between projection rays

We have introduced matrices \mathbf{P} , \mathbf{R} and \mathbf{K} , and vector $\vec{\mathbf{C}}_\delta$ which determine the projection from space to images. However, since \mathbf{K} is introduced with $K_{33} = 1$, the triplet $(\mathbf{K}, \mathbf{R}, \vec{\mathbf{C}}_\delta)$ does not contain all information about the camera, which can be obtained by direct measurement of its physical components in a world coordinate system equipped with a known *world unit length* $\mathbf{1}_W$. The missing element is the scale of \mathbf{P} , which is equivalent to knowing the value of the focal length or the size of pixels, i.e. f , $\|\vec{\mathbf{b}}_1\|$ or $\|\vec{\mathbf{b}}_2\|$, in $\mathbf{1}_W$.

Knowing \mathbf{K} and f allows to recover $\|\vec{\mathbf{b}}_1\|$ from Equations 7.3 as $\|\vec{\mathbf{b}}_1\| = f/k_{11}$. Knowing \mathbf{K} and $\|\vec{\mathbf{b}}_1\|$, on the other hand, gives $f = \|\vec{\mathbf{b}}_1\| k_{11}$.

Therefore, full calibration of the camera is encoded in matrix \mathbf{P}_β , Equation 7.24, or, e.g., in one of the following tuples: $(\mathbf{K}_\beta, \mathbf{R}, \vec{\mathbf{C}}_\delta)$, $(\mathbf{K}, \mathbf{R}, \vec{\mathbf{C}}_\delta, f)$, $(\mathbf{K}, \mathbf{R}, \vec{\mathbf{C}}_\delta, \|\vec{\mathbf{b}}_1\|)$ or $(\mathbf{K}, \mathbf{R}, \vec{\mathbf{C}}_\delta, \|\vec{\mathbf{b}}_2\|)$.

We defined the camera calibration matrix \mathbf{K} with $K_{33} = 1$ because we often do not have access to the world unit when working with images without knowing anything about the camera which was used to make them. Moreover, a number of important tasks can be done without knowing the world unit.

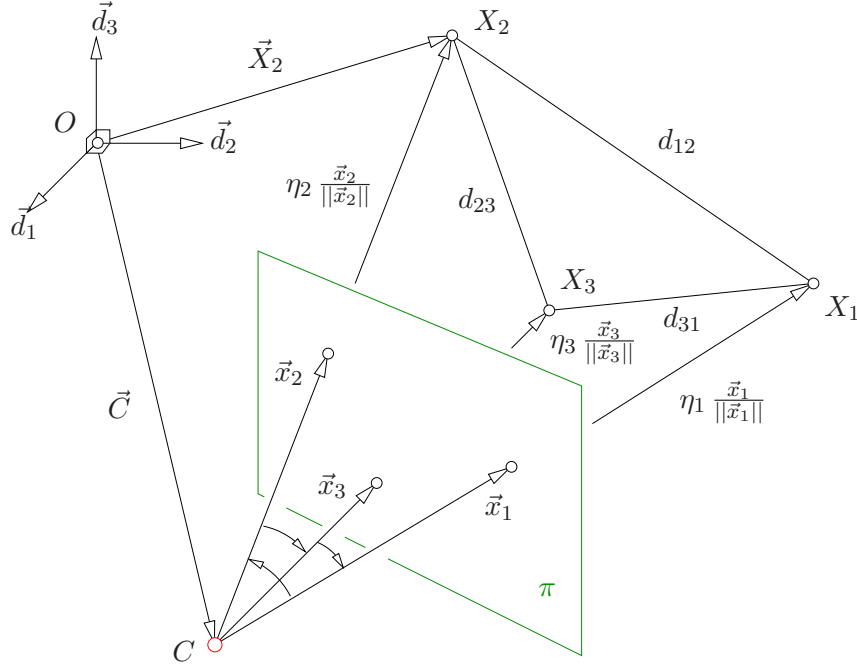

Figure 7.4: A calibrated camera pose can be computed from projections of three known points.

§ 1 Angle between projection rays Consider two image points $\vec{u}_{1\alpha}$ and $\vec{u}_{2\alpha}$. The direction vectors of the rays are in β given by

$$\vec{x}_{1\beta} = \begin{bmatrix} \vec{u}_{1\alpha} \\ 1 \end{bmatrix}, \quad \vec{x}_{2\beta} = \begin{bmatrix} \vec{u}_{2\alpha} \\ 1 \end{bmatrix} \quad (7.54)$$

To obtain the angle between the direction vectors by evaluating the scalar product of the vectors, we need to pass to an orthogonal basis. The “closest” orthogonal basis is γ . Hence

$$\cos \angle(\vec{x}_1, \vec{x}_2) = \frac{\vec{x}_{1\gamma}^\top \vec{x}_{2\gamma}}{\|\vec{x}_{1\gamma}\| \|\vec{x}_{2\gamma}\|} = \frac{\vec{x}_{1\beta}^\top \mathbf{K}^{-\top} \mathbf{K}^{-1} \vec{x}_{2\beta}}{\|\mathbf{K}^{-1} \vec{x}_{1\beta}\| \|\mathbf{K}^{-1} \vec{x}_{2\beta}\|} \quad (7.55)$$

Notice that we could use the orthogonal basis γ to measure angles instead of, e.g., the closest orthonormal basis ϵ since the unknown scale factor f cancels in the following formula

$$\cos \angle(\vec{x}_1, \vec{x}_2) = \frac{\vec{x}_{1\epsilon}^\top \vec{x}_{2\epsilon}}{\|\vec{x}_{1\epsilon}\| \|\vec{x}_{2\epsilon}\|} = \frac{(f \vec{x}_{1\gamma}^\top)(f \vec{x}_{2\gamma})}{\|f \vec{x}_{1\epsilon}\| \|f \vec{x}_{2\gamma}\|} = \frac{\vec{x}_{1\gamma}^\top \vec{x}_{2\gamma}}{\|\vec{x}_{1\gamma}\| \|\vec{x}_{2\gamma}\|} \quad (7.56)$$

We conclude that we do not need to know f to measure angles between projection rays.

7.3 Calibrated camera pose computation

We have seen how to find (uncalibrated) perspective camera pose from projections of known six points. In fact, we have recovered the calibration of the camera. Next we shall show that when

the calibration is known, we are able to find the pose of the camera from projections of three points. This is a very classical problem which has been known since [16].

Figure 7.4 shows a camera with center C , which projects three points X_1 , X_2 and X_3 , represented by vectors $\vec{X}_{1\delta}$, $\vec{X}_{2\delta}$ and $\vec{X}_{3\delta}$ in (O, δ) , into image points represented by $\vec{x}_{1\beta}$, $\vec{x}_{2\beta}$ and $\vec{x}_{3\beta}$.

§ 1 Classical formulation of the calibrated camera pose computation We introduce distances between pairs of points as

$$d_{12} = \|\vec{X}_{2\delta} - \vec{X}_{1\delta}\|, \quad d_{23} = \|\vec{X}_{3\delta} - \vec{X}_{2\delta}\|, \quad d_{31} = \|\vec{X}_{1\delta} - \vec{X}_{3\delta}\| \quad (7.57)$$

Since we see three different points, we know that all distances are positive.

Points X_1 , X_2 and X_3 are in (C, γ) represented by vectors

$$\eta_i \frac{\vec{x}_{i\gamma}}{\|\vec{x}_{i\gamma}\|} = \eta_i \frac{\mathbf{K}^{-1} \vec{x}_{i\beta}}{\|\mathbf{K}^{-1} \vec{x}_{i\beta}\|}, \quad i = 1, 2, 3 \quad (7.58)$$

with η_i representing the distance from C to X_i . Distances η_i are positive since otherwise we could not see the points.

§ 2 Computing distances to the camera center Calibrated perspective camera measures angles between projection rays

$$c_{ij} = \cos \angle(\vec{x}_i, \vec{x}_j) = \frac{\vec{x}_{i\beta}^\top \mathbf{K}^{-\top} \mathbf{K}^{-1} \vec{x}_{j\beta}}{\|\mathbf{K}^{-1} \vec{x}_{i\beta}\| \|\mathbf{K}^{-1} \vec{x}_{j\beta}\|}, \quad i = 1, 2, 3, \quad j = (i - 1) \bmod 3 + 1 \quad (7.59)$$

Hence we have all quantities η_i , $\cos \angle(\vec{x}_i, \vec{x}_j)$ and d_{ij} , which we need to construct a set of equations using the rule of cosines $d_{ij}^2 = \eta_i^2 + \eta_j^2 - 2 \eta_i \eta_j \cos \angle(\vec{x}_i, \vec{x}_j)$, i.e.

$$d_{12}^2 = \eta_1^2 + \eta_2^2 - 2 \eta_1 \eta_2 c_{12} \quad (7.60)$$

$$d_{23}^2 = \eta_2^2 + \eta_3^2 - 2 \eta_2 \eta_3 c_{23} \quad (7.61)$$

$$d_{31}^2 = \eta_3^2 + \eta_1^2 - 2 \eta_3 \eta_1 c_{31} \quad (7.62)$$

with $c_{ij} = \cos \angle(\vec{x}_i, \vec{x}_j)$.

We have three quadratic equations in three variables. We shall solve this system by manipulating the three equations to generate one equation in one variable, solving it and then substituting back to get the remaining two variables.

§ 3 A classical solution Let us first get two equations in two variables. Let us generate new equations by multiplying the left hand side of (7.60) and (7.62) by the right hand side of (7.61) and right hand side of (7.60) and (7.62) by the left hand side of (7.61)

$$d_{12}^2 (\eta_2^2 + \eta_3^2 - 2 \eta_2 \eta_3 c_{23}) = d_{23}^2 (\eta_1^2 + \eta_2^2 - 2 \eta_1 \eta_2 c_{12}) \quad (7.63)$$

$$d_{31}^2 (\eta_2^2 + \eta_3^2 - 2 \eta_2 \eta_3 c_{23}) = d_{23}^2 (\eta_3^2 + \eta_1^2 - 2 \eta_3 \eta_1 c_{31}) \quad (7.64)$$

We could have made three different choices which equation to use twice but since all $d_{ij} \neq 0$, and hence all sides of the equations are nonzero, all the choices are equally valid.

We have now two equations with three variables but since the equations are homogeneous, we will be able to reduce the number of variables to two by dividing equations by (e.g.) η_1^2 (which is non-zero) to get

$$d_{12}^2 (\eta_{12}^2 + \eta_{13}^2 - 2 \eta_{12} \eta_{13} c_{23}) = d_{23}^2 (1 + \eta_{12}^2 - 2 \eta_{12} c_{12}) \quad (7.65)$$

$$d_{31}^2 (\eta_{12}^2 + \eta_{13}^2 - 2 \eta_{12} \eta_{13} c_{23}) = d_{23}^2 (1 + \eta_{13}^2 - 2 \eta_{13} c_{31}) \quad (7.66)$$

with $\eta_{12} = \frac{\eta_2}{\eta_1}$ and $\eta_{13} = \frac{\eta_3}{\eta_1}$. Notice that we have a simpler situation than before with only two quadratic equations in two variables. Let us proceed further towards one equation in one variable.

We rearrange the terms to get a polynomials in η_{13} on the left and the rest on the right

$$\begin{aligned} d_{12}^2 \eta_{13}^2 + (-2 d_{12}^2 \eta_{12} c_{23}) \eta_{13} &= d_{23}^2 (1 + \eta_{12}^2 - 2 \eta_{12} c_{12}) - d_{12}^2 \eta_{12}^2 \\ (d_{31}^2 - d_{23}^2) \eta_{13}^2 + (2 d_{23}^2 c_{31} - 2 d_{31}^2 \eta_{12} c_{23}) \eta_{13} &= d_{23}^2 - d_{31}^2 \eta_{12}^2 \end{aligned} \quad (7.67)$$

to get two quadratic equations

$$m_1 \eta_{13}^2 + p_1 \eta_{13} = q_1 \quad (7.68)$$

$$m_2 \eta_{13}^2 + p_2 \eta_{13} = q_2$$

in η_{13} with

$$m_1 = d_{12}^2 \quad (7.69)$$

$$p_1 = -2 d_{12}^2 \eta_{12} c_{23} \quad (7.70)$$

$$q_1 = d_{23}^2 (1 + \eta_{12}^2 - 2 \eta_{12} c_{12}) - d_{12}^2 \eta_{12}^2 \quad (7.71)$$

$$m_2 = d_{31}^2 - d_{23}^2 \quad (7.72)$$

$$p_2 = 2 d_{23}^2 c_{31} - 2 d_{31}^2 \eta_{12} c_{23} \quad (7.73)$$

$$q_2 = d_{23}^2 - d_{31}^2 \eta_{12}^2 \quad (7.74)$$

We have “hidden” the variable η_{12} in the new coefficients. We can now look upon Equations 7.68 as on a linear system

$$\begin{bmatrix} m_1 & p_1 \\ m_2 & p_2 \end{bmatrix} \begin{bmatrix} \eta_{13}^2 \\ \eta_{13} \end{bmatrix} = \begin{bmatrix} q_1 \\ q_2 \end{bmatrix} \quad (7.75)$$

The matrix of the system (7.75) either is or is not singular.

§ 4 Case A If it is not singular, we can solve the system by Cramer’s rule [6, 7, 5]

$$\eta_{13}^2 \begin{vmatrix} m_1 & p_1 \\ m_2 & p_2 \end{vmatrix} = \begin{vmatrix} q_1 & p_1 \\ q_2 & p_2 \end{vmatrix} \quad (7.76)$$

$$\eta_{13} \begin{vmatrix} m_1 & p_1 \\ m_2 & p_2 \end{vmatrix} = \begin{vmatrix} m_1 & q_1 \\ m_2 & q_2 \end{vmatrix} \quad (7.77)$$

giving

$$\eta_{13}^2 (m_1 p_2 - m_2 p_1) = q_1 p_2 - q_2 p_1 \quad (7.78)$$

$$\eta_{13} (m_1 p_2 - m_2 p_1) = m_1 q_2 - m_2 q_1 \quad (7.79)$$

Eliminating η_{13} (by squaring the second equation, multiplying the first one by $m_1 p_2 - m_2 p_1$, which is non-zero, and comparing the left hand sides) yields

$$(m_1 p_2 - m_2 p_1) (q_1 p_2 - q_2 p_1) = (m_1 q_2 - m_2 q_1)^2 \quad (7.80)$$

Substituting Formulas 7.69-7.74 into Equation 7.80 yields

$$0 = a_4 \eta_{12}^4 + a_3 \eta_{12}^3 + a_2 \eta_{12}^2 + a_1 \eta_{12} + a_0 \quad (7.81)$$

with coefficients

$$a_4 = -d_{23}^8 - d_{12}^4 d_{23}^4 - d_{23}^4 d_{31}^4 - 2 d_{12}^2 d_{23}^4 d_{31}^2 + 2 d_{23}^6 d_{31}^2 + 2 d_{12}^2 d_{23}^6 + 4 d_{12}^2 c_{23}^2 d_{23}^4 d_{31}^2 \quad (7.82)$$

$$a_3 = 4 d_{12}^4 d_{23}^4 c_{31} c_{23} - 4 d_{12}^2 d_{23}^6 c_{12} - 4 d_{12}^2 c_{23} d_{23}^6 c_{31} + 4 d_{23}^4 c_{12} d_{31}^4 + 4 d_{23}^8 c_{12} - 4 d_{12}^2 d_{23}^4 c_{31} d_{31}^2 c_{23} - 8 d_{12}^2 c_{23}^2 d_{23}^4 d_{31}^2 c_{12} - 8 d_{23}^6 c_{12} d_{31}^2 + 4 d_{12}^2 d_{23}^4 c_{12} d_{31}^2 \quad (7.83)$$

$$a_2 = 8 d_{23}^6 c_{12}^2 d_{31}^2 + 4 d_{23}^6 d_{31}^2 - 2 d_{23}^4 d_{31}^4 + 2 d_{12}^4 d_{23}^4 - 4 d_{12}^2 d_{23}^4 c_{31}^2 - 4 d_{23}^8 c_{12}^2 - 4 d_{12}^4 c_{23}^2 d_{23}^4 - 2 d_{23}^8 + 8 d_{12}^2 c_{23} d_{23}^6 c_{31} c_{12} + 4 d_{12}^2 c_{23}^2 d_{23}^4 d_{31}^2 - 4 d_{23}^4 c_{12}^2 d_{31}^4 + 4 d_{12}^2 d_{23}^6 c_{31}^2 + 8 d_{12}^2 d_{23}^4 c_{31} d_{31}^2 c_{23} c_{12} \quad (7.84)$$

$$a_1 = 4 d_{23}^4 c_{12} d_{31}^4 + 4 d_{12}^2 d_{23}^6 c_{12} + 4 d_{23}^8 c_{12} - 4 d_{12}^2 c_{23} d_{23}^6 c_{31} - 8 d_{12}^2 d_{23}^6 c_{31}^2 c_{12} - 4 d_{12}^2 d_{23}^4 c_{31} d_{31}^2 c_{23} - 4 d_{12}^2 d_{23}^4 c_{12} d_{31}^2 + 4 d_{12}^4 d_{23}^4 c_{31} c_{23} - 8 d_{23}^6 c_{12} d_{31}^2 \quad (7.85)$$

$$a_0 = 2 d_{23}^6 d_{31}^2 + 2 d_{12}^2 d_{23}^4 d_{31}^2 - d_{23}^4 d_{31}^4 - d_{12}^4 d_{23}^4 + 4 d_{12}^2 d_{23}^6 c_{31}^2 - d_{23}^8 - 2 d_{12}^2 d_{23}^6 \quad (7.86)$$

We will use eigenvalue computation to find a numerical solution to Equation 7.81. Construct the following *companion matrix*

$$\mathbf{C} = \begin{bmatrix} 0 & 0 & 0 & -\frac{a_0}{a_4} \\ 1 & 0 & 0 & -\frac{a_1}{a_4} \\ 0 & 1 & 0 & -\frac{a_2}{a_4} \\ 0 & 0 & 1 & -\frac{a_3}{a_4} \end{bmatrix} \quad (7.87)$$

and observe that

$$|\eta_{12} \mathbf{I} - \mathbf{C}| = \eta_{12}^4 + \frac{a_3}{a_4} \eta_{12}^3 + \frac{a_2}{a_4} \eta_{12}^2 + \frac{a_1}{a_4} \eta_{12} + \frac{a_0}{a_4} \quad (7.88)$$

Therefore, a numerical approximation of η_{12} can be obtained by computing, e.g., `>>eig(C)` in **Matlab**. Complex solutions are artifacts of the method and should not be further considered. For every real solution, we can then substitute back to Equation 7.79 to obtain the corresponding

$$\begin{aligned} \eta_{13} &= \frac{m_1 q_2 - m_2 q_1}{m_1 p_2 - m_2 p_1} \\ &= \frac{d_{12}^2 (d_{23}^2 - d_{31}^2 \eta_{12}^2) + (d_{23}^2 - d_{31}^2) (d_{23}^2 (1 + \eta_{12}^2 - 2 \eta_{12} c_{12}) - d_{12}^2 \eta_{12}^2)}{2 d_{12}^2 (d_{23}^2 c_{31} - d_{31}^2 c_{23} \eta_{12}) + 2 (d_{31}^2 - d_{23}^2) d_{12}^2 c_{23} \eta_{12}} \end{aligned} \quad (7.89)$$

To get η_1 , η_2 and η_3 , we consider Equation 7.60, which can be rearranged as

$$d_{12}^2 = \eta_1^2 (1 + \eta_{12}^2 - 2 \eta_{12} c_{12}) \quad (7.90)$$

and hence yields positive

$$\eta_1 = \frac{d_{12}}{\sqrt{1 + \eta_{12}^2 - 2 \eta_{12} c_{12}}} \quad (7.91)$$

$$\eta_2 = \eta_1 \eta_{12} \quad (7.92)$$

$$\eta_3 = \eta_1 \eta_{13} \quad (7.93)$$

§ 5 Case B Let us now look at what happens when the matrix of the system (7.75) is singular. Then, after substituting m_1, m_2, p_1 and p_2 from Equations 7.69–7.74, we have

$$m_1 p_2 - m_2 p_1 = 0 \quad (7.94)$$

$$-2 d_{12}^2 d_{23}^2 (\eta_{12} c_{23} - c_{31}) = 0 \quad (7.95)$$

$$\eta_{12} c_{23} = c_{31} \quad (7.96)$$

We used the fact that neither $d_{12} \neq 0$ nor $d_{23} \neq 0$.

§ 6 Case B1 When $c_{23} \neq 0$, then we get

$$\eta_{12} = \frac{c_{31}}{c_{23}} \quad (7.97)$$

Substituting it to Equations 7.65 we get

$$d_{12}^2 \left(\left(\frac{c_{31}}{c_{23}} \right)^2 + \eta_{13}^2 - 2 \frac{c_{31}}{c_{23}} \eta_{13} c_{23} \right) = d_{23}^2 \left(1 + \left(\frac{c_{31}}{c_{23}} \right)^2 - 2 \frac{c_{31}}{c_{23}} c_{12} \right) \quad (7.98)$$

$$d_{12}^2 (c_{31}^2 + c_{23}^2 \eta_{13}^2 - 2 c_{31} c_{23} \eta_{13}) = d_{23}^2 (c_{23}^2 + c_{31}^2 - 2 c_{31} c_{23} c_{12}) \quad (7.99)$$

and after some more manipulation obtain a quadratic equation

$$(d_{12}^2 c_{23}^2) \eta_{13}^2 + (-2 d_{12}^2 c_{23}^2 c_{31}) \eta_{13} + d_{12}^2 c_{31}^2 - d_{23}^2 c_{23}^2 - d_{23}^2 c_{31}^2 + 2 d_{23}^2 c_{12} c_{23} c_{31} = 0 \quad (7.100)$$

in η_{13} . We get η_1, η_2 and η_3 from Equations 7.91, 7.92, 7.93.

§ 7 Case B2 When $c_{23} = 0$, then it follows from Equation 7.96 that $c_{31} = 0$ as well. Returning back to equations 7.65, 7.66 provides

$$d_{12}^2 (\eta_{12}^2 + \eta_{13}^2) = d_{23}^2 (1 + \eta_{12}^2 - 2 \eta_{12} c_{12}) \quad (7.101)$$

$$d_{31}^2 (\eta_{12}^2 + \eta_{13}^2) = d_{23}^2 (1 + \eta_{13}^2) \quad (7.102)$$

Expressing η_{13} from Equation 7.102 gives

$$(d_{23}^2 - d_{31}^2) \eta_{13}^2 = d_{31}^2 \eta_{12}^2 - d_{23}^2 \quad (7.103)$$

§ 8 **Case B2.1** When $d_{23}^2 \neq d_{31}^2$, then we can write

$$\eta_{13}^2 = \frac{d_{31}^2 \eta_{12}^2 - d_{23}^2}{d_{23}^2 - d_{31}^2} \quad (7.104)$$

to substitute it into Equation 7.101

$$d_{12}^2 \left(\eta_{12}^2 + \frac{d_{31}^2 \eta_{12}^2 - d_{23}^2}{d_{23}^2 - d_{31}^2} \right) = d_{23}^2 (1 + \eta_{12}^2 - 2 \eta_{12} c_{12}) \quad (7.105)$$

which we further manipulate to get a quadratic equation in η_{12}

$$(d_{12}^2 - d_{23}^2 + d_{31}^2) \eta_{12}^2 + 2 c_{12} (d_{23}^2 - d_{31}^2) \eta_{12} + d_{31}^2 - d_{12}^2 - d_{23}^2 = 0 \quad (7.106)$$

We get η_1 , η_2 and η_3 from Equations 7.91, 7.92, 7.93.

§ 9 **Case B2.2** Finally, when $d_{23}^2 = d_{31}^2$, then we get from Equation 7.103

$$\eta_{12} = 1 \quad (7.107)$$

and from Equation 7.101

$$\eta_{13}^2 = \frac{d_{23}^2}{d_{12}^2} (2 - 2 c_{12}) - 1 \quad (7.108)$$

and hence the positive

$$\eta_{13} = \sqrt{\frac{d_{23}^2}{d_{12}^2} (2 - 2 c_{12}) - 1} \quad (7.109)$$

We get η_1 , η_2 and η_3 from Equations 7.91, 7.92, 7.93.

§ 10 **Selecting solutions** The above process of η_i computation often delivers several solutions. It is important to notice that some of them may not satisfy the original Equations 7.62–7.60. For instance, we always obtain solutions for the case A as well as for some of the cases B but only one of the cases is actually valid. Hence, we need to select only the solutions that satisfy Equations 7.62–7.60 and are meaningful, i.e. are real and positive.

§ 11 **A modern (more elegant) solution** The classical solution is perfectly valid but it was quite tedious to derive it. Let us now present another, somewhat more elegant, solution, which exploits some of more recent results of algebraic geometry [2, 17].

Let us consider Equations 7.60, 7.61, 7.62 and proceed to Equations 7.65, 7.66, but, this time, using all three pairs to get three equations in η_{12} , η_{13}

$$f_1 = d_{12}^2 (\eta_{12}^2 + \eta_{13}^2 - 2 \eta_{12} \eta_{13} c_{23}) - d_{23}^2 (1 + \eta_{12}^2 - 2 \eta_{12} c_{12}) = 0 \quad (7.110)$$

$$f_2 = d_{31}^2 (\eta_{12}^2 + \eta_{13}^2 - 2 \eta_{12} \eta_{13} c_{23}) - d_{23}^2 (1 + \eta_{13}^2 - 2 \eta_{13} c_{31}) = 0 \quad (7.111)$$

$$f_3 = d_{12}^2 (1 + \eta_{13}^2 - 2 \eta_{13} c_{31}) - d_{31}^2 (1 + \eta_{12}^2 - 2 \eta_{12} c_{12}) = 0 \quad (7.112)$$

It is known [2, 17] that solutions to a set of k algebraic equations

$$f_i(x_1, \dots, x_n) = 0, \quad i = 1 \dots, k \quad (7.113)$$

in n variables, which have a finite number of solutions, can always be obtained by deriving a polynomial $g(x_n) = 0$ in the last variable by the following procedure. If the system, does not have any solution, the procedure will generate polynomial $g_n = 1$, i.e. a non-zero constant, leading to the contradiction $1 = 0$.

The procedure is as follows. First generate new equations by multiplying all f_i by all possible monomials up to degree m

$$x_1, \dots, x_n, x_1^2, x_1 x_2, \dots, x_n^2, x_1^3, x_1^2 x_2, \dots, x_n^m \quad (7.114)$$

to get equations

$$f_1 = 0, \dots, f_n = 0, x_1 f_1 = 0, \dots, x_n f_n = 0, x_1^2 f_1 = 0, x_1 x_2 f_1 = 0, \dots, x_n^m f_n = 0 \quad (7.115)$$

The degree m needs to be chosen such that the next step yields the desired result. It is always possible to choose such m but it may sometimes be found only by using more and more monomials until the Gaussian elimination of the matrix of coefficients, which combine monomials, does not produce a row corresponding to an equation in x_n only. Let us demonstrate this process by solving our problem.

We use the following four monomials of maximal degree two

$$\eta_{12}, \eta_{13}, \eta_{12} \eta_{13}, \eta_{12}^2 \quad (7.116)$$

Notice that we did not include the second degree monomial η_{13}^2 since it turns out that equations generated by that monomial are not necessary. We obtain $15 = 3 + 4 \times 3$ equations

$$\begin{bmatrix} f_1 \\ f_2 \\ f_3 \\ \eta_{12} f_1 \\ \eta_{12} f_2 \\ \eta_{12} f_3 \\ \eta_{13} f_1 \\ \eta_{13} f_2 \\ \eta_{13} f_3 \\ \eta_{12} \eta_{13} f_1 \\ \eta_{12} \eta_{13} f_2 \\ \eta_{12} \eta_{13} f_3 \\ \eta_{12}^2 f_1 \\ \eta_{12}^2 f_2 \\ \eta_{12}^2 f_3 \end{bmatrix} = \mathbf{M} \begin{bmatrix} \eta_{12} \eta_{13}^3 \\ \eta_{13}^3 \\ \eta_{12}^2 \eta_{13}^2 \\ \eta_{13}^2 \eta_{12} \\ \eta_{13}^2 \\ \eta_{12}^3 \eta_{13} \\ \eta_{13} \eta_{12}^2 \\ \eta_{13} \eta_{12} \\ \eta_{13} \\ \eta_{12}^4 \\ \eta_{12}^3 \\ \eta_{12}^3 \\ \eta_{12}^2 \\ \eta_{12} \\ 1 \end{bmatrix} = \mathbf{Mm} = 0 \quad (7.117)$$

with

$$\mathbf{M} = \begin{bmatrix} 0 & 0 & 0 & 0 & m_1 & 0 & 0 & -m_7 & 0 & 0 & 0 & m_4 & m_8 & -m_2 \\ 0 & 0 & 0 & 0 & m_5 & 0 & 0 & m_9 & -m_{10} & 0 & 0 & -m_3 & 0 & m_2 \\ 0 & 0 & 0 & 0 & -m_1 & 0 & 0 & 0 & 0 & m_{11} & 0 & 0 & -m_{12} & m_6 \\ 0 & 0 & 0 & m_1 & 0 & 0 & -m_7 & 0 & 0 & 0 & 0 & m_4 & m_8 & -m_2 \\ 0 & 0 & 0 & m_5 & 0 & 0 & m_9 & -m_{10} & 0 & 0 & 0 & -m_3 & 0 & m_2 \\ 0 & 0 & 0 & -m_1 & 0 & 0 & 0 & 0 & 0 & m_{11} & 0 & 0 & -m_{12} & m_6 \\ 0 & m_1 & 0 & -m_7 & 0 & 0 & m_4 & m_8 & -m_2 & 0 & 0 & 0 & 0 & 0 \\ 0 & m_5 & 0 & m_9 & -m_{10} & 0 & -m_3 & 0 & m_2 & 0 & 0 & 0 & 0 & 0 \\ 0 & -m_1 & 0 & 0 & m_{11} & 0 & m_3 & -m_{12} & m_6 & 0 & 0 & 0 & 0 & 0 \\ m_1 & 0 & -m_7 & 0 & 0 & m_4 & m_8 & -m_2 & 0 & 0 & 0 & 0 & 0 & 0 \\ m_5 & 0 & m_9 & -m_{10} & 0 & -m_3 & 0 & m_2 & 0 & 0 & 0 & 0 & 0 & 0 \\ -m_1 & 0 & 0 & m_{11} & 0 & m_3 & -m_{12} & m_6 & 0 & 0 & 0 & 0 & 0 & 0 \\ 0 & 0 & m_1 & 0 & 0 & -m_7 & 0 & 0 & 0 & m_4 & m_8 & -m_2 & 0 & 0 \\ 0 & 0 & m_5 & 0 & 0 & m_9 & -m_{10} & 0 & 0 & -m_3 & 0 & m_2 & 0 & 0 \\ 0 & 0 & -m_1 & 0 & 0 & 0 & m_{11} & 0 & 0 & m_3 & -m_{12} & m_6 & 0 & 0 \end{bmatrix} \quad (7.118)$$

and

$$\begin{aligned} m_1 &= d_{12}^2 & m_4 &= d_{12}^2 - d_{23}^2 & m_7 &= 2 d_{12}^2 c_{23} & m_{10} &= 2 d_{23}^2 c_{31} \\ m_2 &= d_{23}^2 & m_5 &= d_{23}^2 - d_{31}^2 & m_8 &= 2 d_{23}^2 c_{12} & m_{11} &= 2 d_{12}^2 c_{31} \\ m_3 &= d_{31}^2 & m_6 &= d_{31}^2 - d_{12}^2 & m_9 &= 2 d_{31}^2 c_{23} & m_{12} &= 2 d_{31}^2 c_{12} \end{aligned} \quad (7.119)$$

Matrix \mathbf{M} contains coefficients and vector \mathbf{m} contains the monomials.

Notice in Equation 7.117 that the last five monomials contain only on η_{12} . We have deliberately ordered monomials to achieve this. Next, we do Gaussian elimination (with pivoting) of matrix \mathbf{M} and get a new matrix \mathbf{M}' .

One can verify that that the 10th row of \mathbf{M}' has the first nine elements equal to zero. Therefore

$$\mathbf{M}'_{10,:} \mathbf{m} = 0 \quad (7.120)$$

is a polynomial only in η_{12} . In fact, it is exactly a non-zero multiple of polynomials obtained in cases A, B1, B2.1 and B2.2 above.

Discussion of the cases happens in the Gaussian elimination with pivoting, which avoids dividing by elements close to zero. The resulting polynomial may be of degree four (case A) but will have lower degrees in other cases.

§ 12 Computing camera orientation and camera center Having quantities η_1, η_2, η_3 , we shall compute camera projection center \vec{C}_δ and camera rotation \mathbf{R} from Equation 7.24.

The three points X_1, X_2 and X_3 are represented in the world coordinate system (O, δ) by vectors $\vec{X}_{1\delta}, \vec{X}_{2\delta}$ and $\vec{X}_{3\delta}$. With known η_1, η_2, η_3 , we can represent them also in the camera (orthonormal) coordinate system (C, ϵ) by vectors

$$\vec{Y}_{i\epsilon} = \eta_i \vec{y}_{i\epsilon} = \eta_i \frac{\vec{x}_{i\epsilon}}{\|\vec{x}_{i\epsilon}\|} = \eta_i \frac{f \vec{x}_{i\gamma}}{\|f \vec{x}_{i\gamma}\|} = \eta_i \frac{\vec{x}_{i\gamma}}{\|\vec{x}_{i\gamma}\|}, \quad i = 1, 2, 3 \quad (7.121)$$

Coordinate vectors $\vec{X}_{i\delta}$ are related to coordinate vectors $\vec{Y}_{i\epsilon}$ as follows

$$\vec{Y}_{1\epsilon} = \mathbf{R}(\vec{X}_{1\delta} - \vec{C}_\delta) \quad (7.122)$$

$$\vec{Y}_{2\epsilon} = \mathbf{R}(\vec{X}_{2\delta} - \vec{C}_\delta) \quad (7.123)$$

$$\vec{Y}_{3\epsilon} = \mathbf{R}(\vec{X}_{3\delta} - \vec{C}_\delta) \quad (7.124)$$

There are three vector equations in \mathbb{R}^3 , which is nine scalar equations, and 12 unknowns in \mathbf{R} and \vec{C}_δ . Additional seven equations are provided by the fact that \mathbf{R} is an orthonormal matrix, i.e. $\mathbf{R}^\top \mathbf{R} = \mathbf{I}$ and $|\mathbf{R}| = 1$.

To compute \mathbf{R} , we shall next eliminate \vec{C}_δ from Equations 7.122–7.124

$$\vec{Y}_{2\epsilon} - \vec{Y}_{1\epsilon} = \mathbf{R}(\vec{X}_{2\delta} - \vec{X}_{1\delta}) \quad (7.125)$$

$$\vec{Y}_{3\epsilon} - \vec{Y}_{1\epsilon} = \mathbf{R}(\vec{X}_{3\delta} - \vec{X}_{1\delta}) \quad (7.126)$$

and use the property (Equation 2.45 in Section 2.3)

$$\vec{X}_\epsilon \times \vec{Y}_\epsilon = \frac{\mathbf{R}^{-\top}}{|\mathbf{R}^{-\top}|}(\vec{X}_\delta \times \vec{Y}_\delta) = \mathbf{R}(\vec{X}_\delta \times \vec{Y}_\delta) \quad (7.127)$$

of the vector product of any two vectors \vec{X}, \vec{Y} in \mathbb{R}^3 and an orthonormal matrix \mathbf{R} to write

$$(\vec{Y}_{2\epsilon} - \vec{Y}_{1\epsilon}) \times (\vec{Y}_{3\epsilon} - \vec{Y}_{1\epsilon}) = \left(\mathbf{R}(\vec{X}_{2\delta} - \vec{X}_{1\delta}) \right) \times \left(\mathbf{R}(\vec{X}_{3\delta} - \vec{X}_{1\delta}) \right) \quad (7.128)$$

$$= \mathbf{R} \left((\vec{X}_{2\delta} - \vec{X}_{1\delta}) \times (\vec{X}_{3\delta} - \vec{X}_{1\delta}) \right) \quad (7.129)$$

which provides a triplet of independent vectors expressed in the two bases

$$\vec{Z}_{2\epsilon} = \vec{Y}_{2\epsilon} - \vec{Y}_{1\epsilon}, \quad \vec{Z}_{2\delta} = \vec{X}_{2\delta} - \vec{X}_{1\delta} \quad (7.130)$$

$$\vec{Z}_{3\epsilon} = \vec{Y}_{3\epsilon} - \vec{Y}_{1\epsilon}, \quad \vec{Z}_{3\delta} = \vec{X}_{3\delta} - \vec{X}_{1\delta} \quad (7.131)$$

$$\vec{Z}_{1\epsilon} = \vec{Z}_{2\epsilon} \times \vec{Z}_{3\epsilon}, \quad \vec{Z}_{1\delta} = \vec{Z}_{2\delta} \times \vec{Z}_{3\delta} \quad (7.132)$$

Rotation \mathbf{R} can then be recovered from

$$\begin{bmatrix} \vec{Z}_{1\epsilon} & \vec{Z}_{2\epsilon} & \vec{Z}_{3\epsilon} \end{bmatrix} = \mathbf{R} \begin{bmatrix} \vec{Z}_{1\delta} & \vec{Z}_{2\delta} & \vec{Z}_{3\delta} \end{bmatrix} \quad (7.133)$$

as

$$\mathbf{R} = \begin{bmatrix} \vec{Z}_{1\epsilon} & \vec{Z}_{2\epsilon} & \vec{Z}_{3\epsilon} \end{bmatrix} \begin{bmatrix} \vec{Z}_{1\delta} & \vec{Z}_{2\delta} & \vec{Z}_{3\delta} \end{bmatrix}^{-1} \quad (7.134)$$

With known \mathbf{R} we get \vec{C}_δ as

$$\vec{C}_\delta = \vec{X}_{i\delta} - \mathbf{R}^\top \vec{Y}_{i\epsilon}, \quad i = 1, 2, 3 \quad (7.135)$$

8 Homography

We shall next investigate the relationship between projections of 3D points by two perspective cameras into two images. In general, the projections depend on the shape of the scene and camera poses and this relationship may be very difficult to describe. However, there are several very important situations when the relationship can be given in a form of a special image transform, the *homography*.

Let us first consider the situation when two (different) cameras *share a common projection center*. That means, the cameras may have different coordinate systems, different orientations but *must* have the same projection center. This situation often arises when photographing with a camera rotating around its projection center, e.g., when taking images for constructing a panorama capturing wide view angle. We shall see that the corresponding projections will be related by a homography.

Next, we shall look at a different situation when the cameras are unconstrained, i.e. they can be anywhere in the space and with completely different poses and coordinate systems, but 3D points are forced to lie in a single plane not containing the camera centers. This situation arises, e.g., when photographing a flat screen, a poster or a facade from different viewpoints. Again, the corresponding projections of the points in the plane (but not the projections of the points out of the plane) will be related by a homography.

8.1 Homography between images with the same center

Let us consider two perspective cameras with identical projection centers $C = C'$, which project point X from space to their respective image planes π and π' , Figure 8.1. We introduce image coordinate systems (o, α) with $\alpha = [\vec{b}_1, \vec{b}_2]$ in π and (o', α') with $\alpha' = [\vec{b}'_1, \vec{b}'_2]$ in π' and use them to construct the corresponding camera coordinate systems (C, β) with $\beta = [\vec{b}_1, \vec{b}_2, \vec{b}_3 = \vec{C}o]$ and (C, β') with $\beta' = [\vec{b}'_1, \vec{b}'_2, \vec{b}'_3 = \vec{C}o']$.

Point X is projected to image points along the projection rays, which are intersected with π and π' . The projection of X in π is represented by vector $\vec{u}_\alpha = [u, v]^\top$. The projection of X in π' is represented by vector $\vec{u}'_{\alpha'} = [u', v']^\top$.

Vectors \vec{x} and \vec{x}' are two direction vectors of the same ray and hence *are linearly dependent*. Since they are both non-zero for $X \neq C$, their linear dependence is equivalent with

$$\exists \lambda \in \mathbb{R} : \lambda \vec{x}' = \vec{x} \quad (8.1)$$

To arrive at the relationship between the available coordinates of vectors \vec{x} and \vec{x}' , we shall now pass from vectors to their coordinates. There holds

$$\lambda \vec{x}' = \vec{x} \quad (8.2)$$

$$\lambda \vec{x}'_{\beta'} = \vec{x}_{\beta} \quad (8.3)$$

$$\lambda \vec{x}'_{\beta'} = \mathbf{H} \vec{x}_{\beta} \quad (8.4)$$

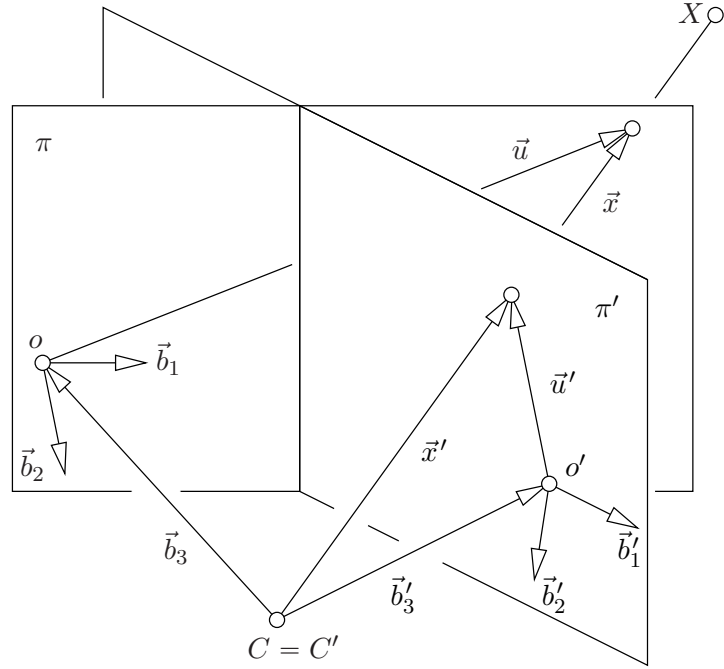

Figure 8.1: Cameras share a projections center. Image projections are related by a homography.

true for some 3×3 real matrix H with $\text{rank } H = 3$, which transforms coordinates of a vector from basis β to basis β' .

Considering the choices of camera coordinate systems, we see that

$$\lambda \vec{x}'_{\beta'} = H \vec{x}_{\beta} \quad (8.5)$$

$$\lambda \begin{bmatrix} u' \\ v' \\ 1 \end{bmatrix} = H \begin{bmatrix} u \\ v \\ 1 \end{bmatrix} \quad (8.6)$$

We have obtained an interesting relationship. The above equations tell us that the image projections are related by a transformation, which depends only on image projections, and to find it, we do not need to know actual positions of points X in space. This is the consequence of having $C = C'$.

§ 1 Relating homography matrix to camera projection matrix Matrix H is related to camera projection matrices. Consider two camera projections given by Equation 6.12

$$\zeta \vec{x}_{\beta} = P \begin{bmatrix} \vec{X}_{\delta} \\ 1 \end{bmatrix} = [K \ R \mid -K\vec{C}_{\delta}] \begin{bmatrix} \vec{X}_{\delta} \\ 1 \end{bmatrix} = K\ R (\vec{X}_{\delta} - \vec{C}_{\delta}) \quad (8.7)$$

$$\zeta' \vec{x}'_{\beta'} = P' \begin{bmatrix} \vec{X}_{\delta} \\ 1 \end{bmatrix} = [K' \ R' \mid -K'\vec{C}'_{\delta}] \begin{bmatrix} \vec{X}_{\delta} \\ 1 \end{bmatrix} = K' \ R' (\vec{X}_{\delta} - \vec{C}_{\delta}) \quad (8.8)$$

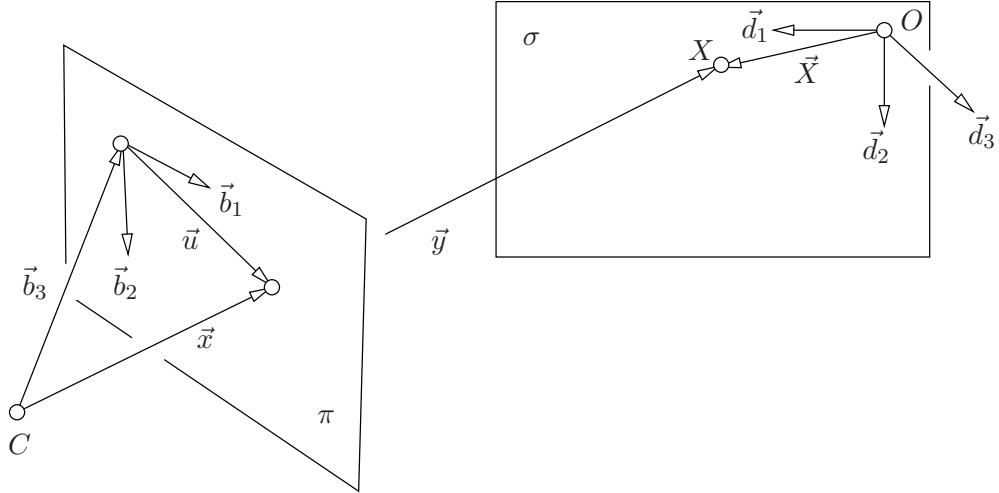

Figure 8.2: All 3D points are in a single plane. Coordinates in the plane and in the image are related by a homography.

for all $\vec{X}_\delta \in \mathbb{R}^3$, which gives

$$\zeta \mathbf{R}^\top \mathbf{K}^{-1} \vec{x}_\beta = \vec{X}_\delta - \vec{C}_\delta \quad (8.9)$$

$$\zeta' \mathbf{R}'^\top \mathbf{K}'^{-1} \vec{x}'_{\beta'} = \vec{X}_\delta - \vec{C}_\delta \quad (8.10)$$

and therefore

$$\zeta' \mathbf{R}'^\top \mathbf{K}'^{-1} \vec{x}'_{\beta'} = \zeta \mathbf{R}^\top \mathbf{K}^{-1} \vec{x}_\beta \quad (8.11)$$

$$\frac{\zeta'}{\zeta} \vec{x}_{\beta'} = \mathbf{K}' \mathbf{R}' \mathbf{R}^\top \mathbf{K}^{-1} \vec{x}_\beta \quad (8.12)$$

for all corresponding pairs of vectors $\vec{x}_\beta, \vec{x}'_{\beta'}$. Let us now compare Equation 8.12 with Equation 8.5, i.e. with

$$\lambda \vec{x}'_{\beta'} = \mathbf{H} \vec{x}_\beta \quad (8.13)$$

We see that

$$\mathbf{H} = \mathbf{K}' \mathbf{R}' \mathbf{R}^\top \mathbf{K}^{-1} \quad \text{when} \quad \lambda = \frac{\zeta'}{\zeta} \quad (8.14)$$

This is particularly useful when $\mathbf{K} = \mathbf{K}'$ since then

$$\mathbf{H} = \mathbf{K} \mathbf{R}' \mathbf{R}^\top \mathbf{K}^{-1} \quad (8.15)$$

which implies that \mathbf{H} is similar [5] to a rotation, i.e.

$$\mathbf{K}^{-1} \mathbf{H} \mathbf{K} = \mathbf{R}' \mathbf{R}^\top \quad (8.16)$$

and hence has one eigenvalue equal to one, the other two eigenvalues are complex conjugate with modulae [3] equal to one.

§ 2 Homographies conjugated to rotations Let us study homographies \mathbf{H} conjugated to rotations $\mathbf{S} = \mathbf{R}'\mathbf{R}$ as in Equation 8.16. We shall first check that such homographies are characterized by the following condition

$$\text{eig}(\mathbf{H}) = (1, x + iy, x - iy) \text{ for some real } x, y \text{ such that } x^2 + y^2 = 1 \quad (8.17)$$

Eigenvalues of a rotation \mathbf{S} can be written as $(1, x + iy, x - iy)$ for some real x, y such that $x^2 + y^2 = 1$. Consider

$$|\mathbf{H} - \lambda \mathbf{I}| = |\mathbf{K}^{-1}| |\mathbf{H} - \lambda \mathbf{I}| |\mathbf{K}| = |\mathbf{K}^{-1} \mathbf{H} \mathbf{K} - \mathbf{K}^{-1} \lambda \mathbf{I} \mathbf{K}| = |\mathbf{S} - \lambda \mathbf{I}| \quad (8.18)$$

and therefore eigenvalues of \mathbf{H} are equal to eigenvalues of \mathbf{S} .

Next, assume that eigenvalues of \mathbf{H} are equal to eigenvalues of a rotation \mathbf{S} . Then we can write

$$\mathbf{S} \mathbf{U} = \mathbf{U} \mathbf{\Lambda} \quad \text{and} \quad \mathbf{H} \mathbf{V} = \mathbf{V} \mathbf{\Lambda} \quad (8.19)$$

for a matrix $\mathbf{\Lambda}$ with the eigenvalues on the diagonal and matrices \mathbf{U} , resp. \mathbf{V} , of eigenvectors of \mathbf{S} , resp. \mathbf{H} . Now, if $y \neq 0$, the eigenvalues are pairwise distinct. Then it is possible [4, 5] to construct matrices \mathbf{U} , \mathbf{V} , from the respective eigenvectors of unit length such that they are regular, and we can write

$$\mathbf{\Lambda} = \mathbf{\Lambda} \quad (8.20)$$

$$\mathbf{V}^{-1} \mathbf{H} \mathbf{V} = \mathbf{U}^{-1} \mathbf{S} \mathbf{U} \quad (8.21)$$

$$\mathbf{U} \mathbf{V}^{-1} \mathbf{H} \mathbf{V} \mathbf{U}^{-1} = \mathbf{S} \quad (8.22)$$

$$\mathbf{Q}^{-1} \mathbf{K}^{-1} \mathbf{H} \mathbf{K} \mathbf{Q} = \mathbf{S} \quad (8.23)$$

$$\mathbf{K}^{-1} \mathbf{H} \mathbf{K} = \mathbf{Q} \mathbf{S} \mathbf{Q}^{-1} \quad (8.24)$$

We introduced an upper triangular matrix \mathbf{K} and a rotation \mathbf{Q} such that $\mathbf{V} \mathbf{U}^{-1} = \mathbf{K} \mathbf{Q}$, which is always possible by the Gramm-Schmid orthogonalization process [5]. Matrix $\mathbf{Q} \mathbf{S} \mathbf{Q}^{-1}$ is a rotation and thus \mathbf{H} is similar to a rotation by an upper triangular matrix.

If $y = 0$ then the eigenvalues are either $(1, 1, 1)$ or $(1, -1, -1)$. In the former case, $\mathbf{S} = \mathbf{I}$ and hence $\mathbf{K}^{-1} \mathbf{H} \mathbf{K} = \mathbf{I}$ implies $\mathbf{H} = \mathbf{I}$, and hence \mathbf{H} is a rotation. In the latter case, \mathbf{S} is a rotation by 180° and \mathbf{H} is thus similar to a rotation.

Let us now characterize the homographies conjugated to a rotation algebraically. The characteristic polynomial of \mathbf{H} is as follows

$$p(\lambda) = |\lambda \mathbf{I} - \mathbf{H}| = (\lambda - 1)(\lambda - x - yi)(\lambda - x + yi) \quad (8.25)$$

$$= \lambda^3 - (2x + 1)\lambda^2 + (2x + 1)\lambda - 1 \quad (8.26)$$

$$= \lambda^3 - \text{trace} \mathbf{H} \lambda^2 + (\mathbf{H}_{11} + \mathbf{H}_{22} + \mathbf{H}_{33}) \lambda - |\mathbf{H}| \quad (8.27)$$

since $x^2 + y^2 = 1$. Symbols \mathbf{H}_{ij} denote minors after removing row i and column j . We are thus getting two algebraic constraints on \mathbf{H}

$$\text{trace} \mathbf{H} = \mathbf{H}_{11} + \mathbf{H}_{22} + \mathbf{H}_{33} \quad \text{and} \quad |\mathbf{H}| = 1 \quad (8.28)$$

which are polynomials of degree two and three in elements of \mathbf{H} , respectively, which is a representative of the homography. Clearly, any-nonzero multiple of \mathbf{H} satisfying Equation 8.28 also

represents the same homography and therefore rank three matrices constrained by the first equation in Equation 8.28 are permissible representatives of homographies between images obtained by a rotating camera with constant internal calibration.

Finally, when $\mathbf{K} = \mathbf{K}' = \mathbf{I}$, then $\mathbf{H} = \mathbf{S}$, i.e. a rotation, is a representative of such homography and hence all non-zero multiples of rotations are permissible representatives of homographies between images obtained by a rotating calibrated camera.

8.2 Homography between images of a plane

8.2.1 Image of a plane

Let study the relationship between the coordinates of 3D points X , which all lie in a plane σ , and their projections into an image, Figure 8.2. Coordinates of points X are measured in a coordinate system (O, δ) with $\delta = [\vec{d}_1, \vec{d}_2, \vec{d}_3]$. Vectors \vec{d}_1, \vec{d}_2 span plane σ and therefore

$$\vec{X}_\delta = \begin{bmatrix} x \\ y \\ 0 \end{bmatrix} \quad (8.29)$$

for some real x, y .

The points X are projected by a perspective camera with projection matrix \mathbf{P} into image coordinates $\vec{u}_\alpha = [u, v]^\top$, w.r.t. an image coordinate system (o, α) with $\alpha = [\vec{b}_1, \vec{b}_2]$. The corresponding camera coordinate system is (C, β) with $\beta = (\vec{b}_1, \vec{b}_2, \vec{b}_3)$.

To find the relationship between the coordinates of \vec{X}_δ and \vec{u}_α , we project points X by \mathbf{P} into projections \vec{x}_β as

$$\zeta \begin{bmatrix} u \\ v \\ 1 \end{bmatrix} = \zeta \vec{x}_\beta = \mathbf{P} \begin{bmatrix} \vec{X}_\delta \\ 1 \end{bmatrix} = [\mathbf{p}_1 \ \mathbf{p}_2 \ \mathbf{p}_3 \ \mathbf{p}_4] \begin{bmatrix} x \\ y \\ 0 \\ 1 \end{bmatrix} = [\mathbf{p}_1 \ \mathbf{p}_2 \ \mathbf{p}_4] \begin{bmatrix} x \\ y \\ 1 \end{bmatrix} = \mathbf{H} \vec{y}_\tau \quad (8.30)$$

where $\mathbf{p}_1, \mathbf{p}_2, \mathbf{p}_3, \mathbf{p}_4$ are the columns of \mathbf{P} .

Notice that 3×1 matrix $\vec{y}_\tau = [x, y, 1]^\top$ represents point X in the coordinate system (C, τ) with the basis $\tau = (\vec{d}_1, \vec{d}_2, \vec{d}_4)$, where the $\vec{d}_4 = \vec{CO}$ is the vector assigned to the pair of points (C, O) . If point C is not in σ , then vectors $\vec{d}_1, \vec{d}_2, \vec{d}_4$ are independent and hence form a basis. Therefore, matrix

$$\mathbf{H} = [\mathbf{p}_1 \ \mathbf{p}_2 \ \mathbf{p}_4] \quad (8.31)$$

represents a change of coordinates and has rank 3.

When we think about pair (C, σ) as about a camera that shares its projection center with camera (C, π) and imagine that points X are all (accidentally) in the projection plane σ , we see that we have recovered the relationship between cameras sharing their projection center.

8.2.2 Two images of a plane

We shall now consider the situation when all points in the scene are in a single plane. Then, as we shall see, the projections of the 3D points, which are in the plane, are again related by a homography even when the camera centers are located at different points in the space.

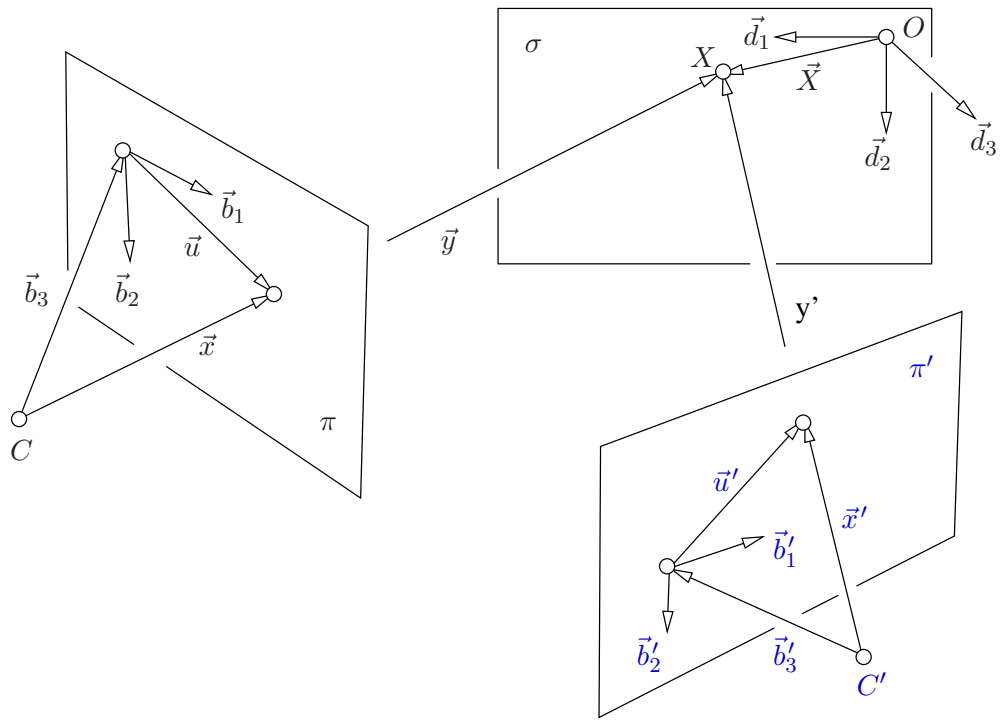

Figure 8.3: All 3D points are in a single plane. Two images of the points are related by a homography.

Let us consider a plane σ and two perspective cameras with (in general different) projection centers C and C' , which do not lie in σ and the corresponding projection matrices P and P'

$$P = [p_1 \ p_2 \ p_3 \ p_4] \quad (8.32)$$

$$P' = [p'_1 \ p'_2 \ p'_3 \ p'_4] \quad (8.33)$$

where $p_i \in \mathbb{R}^3$ and $p'_i \in \mathbb{R}^3$, $i = 1, \dots, 4$ stand for the columns of P , P' .

We establish coordinate systems (O, δ) , (C, β) , (C', β') in the standard way, see Figure 8.3 to get

$$\vec{X}_\delta = \begin{bmatrix} x \\ y \\ 0 \\ 1 \end{bmatrix} \quad (8.34)$$

for some real x, y .

Point $X \in \sigma$ is projected to the cameras as

$$\zeta \vec{x}_\beta = P \begin{bmatrix} \vec{X}_\delta \\ 1 \end{bmatrix} = [p_1 \ p_2 \ p_3 \ p_4] \begin{bmatrix} x \\ y \\ 0 \\ 1 \end{bmatrix} = [p_1 \ p_2 \ p_4] \begin{bmatrix} x \\ y \\ 1 \end{bmatrix} = G \vec{y}_\tau$$

$$\zeta' \vec{x}'_{\beta'} = P' \begin{bmatrix} \vec{X}_\delta \\ 1 \end{bmatrix} = [p'_1 \ p'_2 \ p'_3 \ p'_4] \begin{bmatrix} x \\ y \\ 0 \\ 1 \end{bmatrix} = [p'_1 \ p'_2 \ p'_4] \begin{bmatrix} x \\ y \\ 1 \end{bmatrix} = G' \vec{y}'_{\tau'}$$

for some $\zeta, \zeta' \in \mathbb{R} \setminus \{0\}$ and two new coordinate systems (C, τ) with $\tau = (\vec{d}_1, \vec{d}_2, \vec{d}_4)$, where the $\vec{d}_4 = \overrightarrow{CO}$ and (C', τ') with $\tau' = (\vec{d}'_1, \vec{d}'_2, \vec{d}'_4)$, where the $\vec{d}'_4 = \overrightarrow{C'O'}$.

We see that there are two different vectors, \vec{y} and \vec{y}' , which appear on the right hand side of the equations in different bases, i.e. as \vec{y}_τ and $\vec{y}'_{\tau'}$,

$$\zeta \vec{x}_\beta = G \vec{y}_\tau \quad (8.35)$$

$$\zeta' \vec{x}'_{\beta'} = G' \vec{y}'_{\tau'} \quad (8.36)$$

with $G = [p_1, p_2, p_4]$ and $G' = [p'_1, p'_2, p'_4]$.

Coordinate systems (C, τ) and (C', τ') are so special that

$$\vec{y}_\tau = \vec{y}'_{\tau'} \quad (8.37)$$

for all points in σ . Consider that

$$\vec{y}_\tau = (\vec{X} + \overrightarrow{CO})_\tau = \vec{X}_\tau + \vec{d}_{4\tau} = \vec{X}_{(\vec{d}_1, \vec{d}_2, \vec{d}_4)} + \vec{d}_{4(\vec{d}_1, \vec{d}_2, \vec{d}_4)} = \begin{bmatrix} x \\ y \\ 1 \end{bmatrix} \quad (8.38)$$

$$\vec{y}'_{\tau'} = (\vec{X} + \overrightarrow{C'O'})_{\tau'} = \vec{X}_{\tau'} + \vec{d}'_{4\tau'} = \vec{X}_{(\vec{d}'_1, \vec{d}'_2, \vec{d}'_4)} + \vec{d}'_{4(\vec{d}'_1, \vec{d}'_2, \vec{d}'_4)} = \begin{bmatrix} x \\ y \\ 1 \end{bmatrix} \quad (8.39)$$

and therefore, when $C \notin \sigma$ and $C' \notin \sigma$, we get

$$\zeta' \vec{x}'_{\beta'} = G' G^{-1} \zeta \vec{x}_\beta \quad (8.40)$$

which we can write as

$$\lambda \vec{x}'_{\beta'} = \mathbf{H} \vec{x}_{\beta} \quad (8.41)$$

for $\lambda = \frac{\zeta'}{\zeta}$ and $\mathbf{H} = \mathbf{G}' \mathbf{G}^{-1}$. Clearly, $\mathbf{H} \in \mathbb{R}^{3 \times 3}$, $\text{rank } \mathbf{H} = 3$.

We could also interpret this situation such that two images of a plane are related by the homography, which is a combination of the homographies relating the plane to its two images.

8.2.3 Homography between images of a plane by cameras with the same center

In the derivation of Equation 8.41, we have never asked for centers C, C' be different. Indeed, Equation 8.40 is perfectly valid even when $C = C'$. At the same time, however, there also holds Equation 8.14 true, and thus we have

$$\mathbf{H} = \mathbf{G}' \mathbf{G}^{-1} \quad (8.42)$$

$$= [\mathbf{p}'_1 \ \mathbf{p}'_2 \ \mathbf{p}'_4] [\mathbf{p}_1 \ \mathbf{p}_2 \ \mathbf{p}_4]^{-1} \quad (8.43)$$

$$\mathbf{H} = \mathbf{K}' \mathbf{R}' \mathbf{R}^{\top} \mathbf{K}^{-1} \quad (8.44)$$

$$= [\mathbf{p}'_1 \ \mathbf{p}'_2 \ \mathbf{p}'_3] [\mathbf{p}_1 \ \mathbf{p}_2 \ \mathbf{p}_3]^{-1} \quad (8.45)$$

Let us see now purely algebraic argument why the above holds true. Since the cameras have the same projection center $\vec{C}_{\delta} = [c_1 \ c_2 \ c_3]^{\top}$, we can write

$$\mathbf{p}_4 = -\mathbf{K} \mathbf{R} \vec{C}_{\delta} \quad \text{and} \quad \mathbf{p}'_4 = -\mathbf{K}' \mathbf{R}' \vec{C}_{\delta} \quad (8.46)$$

and hence

$$\mathbf{H} = \mathbf{G}' \mathbf{G}^{-1} \quad (8.47)$$

$$= [\mathbf{p}'_1 \ \mathbf{p}'_2 \ \mathbf{p}'_4] [\mathbf{p}_1 \ \mathbf{p}_2 \ \mathbf{p}_4]^{-1} \quad (8.48)$$

$$= \mathbf{K}' \mathbf{R}' \begin{bmatrix} \mathbf{i} & \mathbf{j} & -\vec{C}_{\delta} \end{bmatrix} \begin{bmatrix} \mathbf{i} & \mathbf{j} & -\vec{C}_{\delta} \end{bmatrix}^{-1} \mathbf{R}^{\top} \mathbf{K}^{-1} \quad (8.49)$$

$$= \mathbf{K}' \mathbf{R}' \mathbf{R}^{\top} \mathbf{K}^{-1} \quad (8.50)$$

with $\mathbf{i} = [1 \ 0 \ 0]^{\top}$ and $\mathbf{j} = [0 \ 1 \ 0]^{\top}$. We see that there always holds

$$[\mathbf{p}'_1 \ \mathbf{p}'_2 \ \mathbf{p}'_4] [\mathbf{p}_1 \ \mathbf{p}_2 \ \mathbf{p}_4]^{-1} = [\mathbf{p}'_1 \ \mathbf{p}'_2 \ \mathbf{p}'_3] [\mathbf{p}_1 \ \mathbf{p}_2 \ \mathbf{p}_3]^{-1} \quad (8.51)$$

true for two cameras with the same projection center irrespectively of where actually the points in space are since we would get the same images for points obtained by intersecting the rays with the plane $z = 0$ in the coordinate system (O, δ) .

8.2.4 Homographies induced by a plane in the scene

Let us look at Equation 8.40 in more detail. We can write

$$\frac{\zeta'}{\zeta} \vec{x}'_{\beta'} = \mathbf{G}' \mathbf{G}^{-1} \vec{x}_{\beta} = [\mathbf{p}'_1 \ \mathbf{p}'_2 \ \mathbf{p}'_4] [\mathbf{p}_1 \ \mathbf{p}_2 \ \mathbf{p}_4]^{-1} \vec{x}_{\beta} \quad (8.52)$$

$$= \mathbf{A}' \begin{bmatrix} 1 & 0 & -\vec{C}'_{\delta} \\ 0 & 1 & \\ 0 & 0 & \end{bmatrix} \begin{bmatrix} 1 & 0 & \\ 0 & 1 & -\vec{C}_{\delta} \\ 0 & 0 & \end{bmatrix}^{-1} \mathbf{A}^{-1} \vec{x}_{\beta} \quad (8.53)$$

$$= \mathbf{A}' \begin{bmatrix} 1 & 0 & -x' \\ 0 & 1 & -y' \\ 0 & 0 & -z' \end{bmatrix} \begin{bmatrix} 1 & 0 & -x \\ 0 & 1 & -y \\ 0 & 0 & -z \end{bmatrix}^{-1} \mathbf{A}^{-1} \vec{x}_{\beta} \quad (8.54)$$

We have introduced new symbols to represent vectors

$$\vec{C}_{\delta} = [x \ y \ z]^{\top} \quad \text{and} \quad \vec{C}'_{\delta} = [x' \ y' \ z']^{\top} \quad (8.55)$$

and have written the homography as a product of four matrices. Let us next compute the product of the two middle matrices

$$\frac{\zeta'}{\zeta} \vec{x}'_{\beta'} = \mathbf{A}' \begin{bmatrix} 1 & 0 & (x' - x)/z \\ 0 & 1 & (y' - y)/z \\ 0 & 0 & z'/z \end{bmatrix} \mathbf{A}^{-1} \vec{x}_{\beta} \quad (8.56)$$

We see that the middle matrix on the right looks almost as the identity plus something. Let's express it in that way

$$\frac{\zeta'}{\zeta} \vec{x}'_{\beta'} = \mathbf{A}' \begin{bmatrix} 1 & 0 & (x' - x)/z \\ 0 & 1 & (y' - y)/z \\ 0 & 0 & 1 + (z' - z)/z \end{bmatrix} \mathbf{A}^{-1} \vec{x}_{\beta} \quad (8.57)$$

We can now further rearrange expressions as follows

$$\frac{\zeta'}{\zeta} \vec{x}'_{\beta'} = \mathbf{A}' \left(\mathbf{I} + \begin{bmatrix} (x' - x)/z \\ (y' - y)/z \\ (z' - z)/z \end{bmatrix} [0 \ 0 \ 1] \right) \mathbf{A}^{-1} \vec{x}_{\beta} \quad (8.58)$$

$$= \mathbf{A}' \left(\mathbf{I} + (\vec{C}'_{\delta} - \vec{C}_{\delta}) \frac{1}{\vec{C}_{\delta}(3)} [0 \ 0 \ 1] \right) \mathbf{A}^{-1} \vec{x}_{\beta} \quad (8.59)$$

$$= \mathbf{A}' \mathbf{A}^{-1} \left(\mathbf{I} - (\vec{C}_{\beta} - \vec{C}'_{\beta}) \frac{1}{\vec{C}_{\delta}(3)} [0 \ 0 \ 1] \mathbf{A}^{-1} \right) \vec{x}_{\beta} \quad (8.60)$$

We denoted the third coordinate of \vec{C}_{δ} by $\vec{C}_{\delta}(3)$.

Vector $\frac{1}{\vec{C}_{\delta}(3)} [0 \ 0 \ 1] \mathbf{A}^{-1}$ has a geometrical interpretation. Consider the equation of plane σ in coordinate system (O, δ)

$$[0 \ 0 \ 1 \ 0] \begin{bmatrix} \vec{X}_{\delta} \\ 1 \end{bmatrix} = 0 \quad (8.61)$$

where $[0 \ 0 \ 1]^\top$ is the normal vector of plane σ containing point \vec{X}_δ written w.r.t. (O, δ) , i.e. $\vec{n}_\delta^\top = [0 \ 0 \ 1]$, where δ is the dual basis to basis δ , Chapter 2.

Next, consider the camera coordinate system (C, β) with $\vec{Y}_\beta = \mathbf{A}(\vec{X}_\delta - \vec{C}_\delta)$. We see that

$$[0 \ 0 \ 1 \ 0] \begin{bmatrix} \mathbf{A}^{-1} \vec{Y}_\beta + \vec{C}_\delta \\ 1 \end{bmatrix} = 0 \quad (8.62)$$

$$\left[[0 \ 0 \ 1] \mathbf{A}^{-1} \quad \vec{C}_\delta(3) \right] \begin{bmatrix} \vec{Y}_\beta \\ 1 \end{bmatrix} = 0 \quad (8.63)$$

provides the unit normal \vec{n} of plane σ in the dual basis $\bar{\beta}$ to basis β

$$\vec{n}_{\bar{\beta}}^\top = [0 \ 0 \ 1] \mathbf{A}^{-1} \quad (8.64)$$

We have obtained the following formula for the homography between points $\vec{x}_\beta, \vec{x}'_{\beta'}$ in the two images, which is generated by the plane σ

$$\frac{\zeta'}{\zeta} \vec{x}'_{\beta'} = \mathbf{A}' \mathbf{A}^{-1} \left(\mathbf{I} + (\vec{C}'_{\beta'} - \vec{C}_\beta) \frac{1}{\vec{C}_\delta(3)} \vec{n}_{\bar{\beta}}^\top \right) \vec{x}_\beta \quad (8.65)$$

where $\vec{n}_{\bar{\beta}}$ is the normal vector of σ in $\bar{\beta}$, $\vec{C}_\delta(3)$ is the distance of σ from the camera center C , and ζ, ζ' are the distances of points from the respective principal planes in multiples of the respective focal lengths.

§ 1 One fully calibrated camera We will now consider Equation 8.65 for the situation when the first camera is fully calibrated, i.e.

$$\mathbf{P}_1 = [\mathbf{I} \mid -\vec{C}_\delta] \quad \text{and} \quad \mathbf{P}_2 = [\mathbf{A}' \mid \mathbf{a}'] = [\mathbf{A}' \mid -\mathbf{A}' \vec{C}'_{\beta'}] \quad (8.66)$$

Then, bases β_1 and δ become identical and Equation 8.65 can be written as

$$\tau' \vec{x}'_{\beta'} = \mathbf{A}' \left(\mathbf{I} + (\vec{C}'_{\delta} - \vec{C}_\delta) \frac{\vec{n}_\delta^\top}{d} \right) \vec{x}_\delta = \left(\mathbf{A}' - \frac{\vec{t}_{\beta'}}{d} \vec{n}_\delta^\top \right) \vec{x}_\delta = \left(\mathbf{A}' - \frac{\vec{t}_{\beta'}}{d} \vec{n}_\delta^\top \right) \vec{x}_\delta \quad (8.67)$$

where $\vec{t}_{\beta'}$ are the coordinates of the vector from C to C' in β' . Notice that we have used the fact that δ is the standard basis and therefore \vec{n}_δ transforms by the same matrix as \vec{X}_δ when changing a basis. To stress that, we use \vec{n}_δ instead of $\vec{n}_{\bar{\delta}}$. Symbol d stands for the (non-zero) distance of the plane σ from the center of the first camera, and a non-zero $\tau' = \zeta'/\zeta$.

§ 2 Two internally calibrated cameras Let us next have a look at the situation when $\mathbf{K} = \mathbf{K}' = \mathbf{I}$. Matrices \mathbf{A}, \mathbf{A}' become rotations, which we stress by writing

$$\mathbf{P}_1 = [\mathbf{R} \mid -\mathbf{R} \vec{C}_\delta] \quad \text{and} \quad \mathbf{P}_2 = [\mathbf{R}' \mid -\mathbf{R}' \vec{C}'_{\beta'}] \quad (8.68)$$

with orthonormal matrices \mathbf{R}, \mathbf{R}' . Equation 8.65 now becomes

$$\tau' \vec{x}'_{\gamma'} = \mathbf{R}' \mathbf{R}^{-1} \left(\mathbf{I} + (\vec{C}'_{\gamma'} - \vec{C}_\gamma) \frac{1}{\vec{C}_\delta(3)} \vec{n}_{\bar{\gamma}}^\top \right) \vec{x}_\gamma = \left(\mathbf{R}' \mathbf{R}^{-1} + \frac{\vec{t}_{\gamma'}}{d} \vec{n}_{\bar{\gamma}}^\top \right) \vec{x}_\gamma \quad (8.69)$$

A question arises here. Does every rank three real 3×3 matrix represent a homography between two calibrated images induced by a plane in the scene? We see from the following that the answer is yes.

Let us consider a real 3×3 matrix \mathbf{H} and its SVD decomposition [5, p. 411]

$$\mathbf{H} = \mathbf{U} \begin{bmatrix} a & & \\ & b & \\ & & c \end{bmatrix} \mathbf{V}^\top \quad (8.70)$$

Now, if $|\mathbf{H}| > 0$, then we may ask for $a \geq b \geq c \geq 0$ and $|\mathbf{U}| = |\mathbf{V}| = 1$. Otherwise, we replace c by $-c$ to have $a \geq b > 0 > c$ and $|\mathbf{U}| = |\mathbf{V}| = 1$. Next, when any two of a, b, c are equal, e.g. $a = b$, then we can write the decomposition as follows

$$\mathbf{H} = \mathbf{U} \begin{bmatrix} a & & \\ & b & \\ & & c \end{bmatrix} \mathbf{V}^\top = \mathbf{U} \begin{bmatrix} b & & \\ & b & \\ & & c \end{bmatrix} \mathbf{V}^\top \quad (8.71)$$

$$= \mathbf{U} \left(b \begin{bmatrix} 1 & & \\ & 1 & \\ & & 1 \end{bmatrix} + \begin{bmatrix} 0 & & \\ & 0 & \\ c-b & & \end{bmatrix} \begin{bmatrix} 0 & 0 & 1 \end{bmatrix} \right) \mathbf{V}^\top \quad (8.72)$$

$$= b\mathbf{U}\mathbf{V}^\top + \mathbf{U} \begin{bmatrix} 0 & & \\ & 0 & \\ c-b & & \end{bmatrix} \begin{bmatrix} 0 & 0 & 1 \end{bmatrix} \mathbf{V}^\top \quad (8.73)$$

Hence, we need to consider only the situation when a, b, c are pairwise distinct. We can write

$$\begin{aligned} \mathbf{H} &= b\mathbf{U}\mathbf{S}\mathbf{V}^\top + \mathbf{U}\mathbf{u}\mathbf{v}^\top \mathbf{V}^\top = b\mathbf{R} + \mathbf{t}\mathbf{n}^\top \\ \mathbf{S} &= \begin{bmatrix} \frac{ac+b^2}{b(a+c)} & 0 & -\frac{\sqrt{b^2-c^2}\sqrt{a^2-b^2}}{b(a+c)} \\ 0 & 1 & 0 \\ \frac{\sqrt{b^2-c^2}\sqrt{a^2-b^2}}{b(a+c)} & 0 & \frac{ac+b^2}{b(a+c)} \end{bmatrix} \\ \mathbf{u} &= \begin{bmatrix} \frac{\sqrt{a^2-b^2}}{a+c} \\ 0 \\ -\frac{\sqrt{b^2-c^2}}{a+c} \end{bmatrix} \\ \mathbf{v}^\top &= \begin{bmatrix} \sqrt{a^2-b^2} & 0 & \sqrt{b^2-c^2} \end{bmatrix} \end{aligned}$$

Notice that b is non-zero since it must be greater than c else we would have $b = c$, which we excluded. Moreover, $a + c > 0$ since they are either both positive or $|a| > |c|$ and a is positive. Hence all the formulas above are meaningful. It is easy to verify that $\mathbf{S}^\top \mathbf{S} = \mathbf{I}$ and $|\mathbf{S}| = 1$ and therefore $\mathbf{R} = \mathbf{U}\mathbf{S}\mathbf{V}^\top$ is a rotation.

Consider a rank three real 3×3 matrix \mathbf{H} . We see that it must be possible to write a non-zero multiple of \mathbf{H} as $\mathbf{S} + \vec{v}_\gamma, \vec{n}_\gamma^\top$ for some rotation \mathbf{S} and vectors $\vec{v}_\gamma \in \mathbb{R}^3$ and unit $\vec{n}_\gamma \in \mathbb{R}^3$. Hence, the following equations

$$(\xi \mathbf{H} - \vec{v}_\gamma, \vec{n}_\gamma^\top)^\top (\xi \mathbf{H} - \vec{v}_\gamma, \vec{n}_\gamma^\top) = \mathbf{I}, \quad |(\xi \mathbf{H} - \vec{v}_\gamma, \vec{n}_\gamma^\top)| = 1, \quad \vec{n}_\gamma^\top \vec{n}_\gamma = 1 \quad (8.74)$$

have to be satisfied for some real ξ and some vectors $\vec{v}_\gamma \in \mathbb{R}^3$ and unit $\vec{n}_\gamma \in \mathbb{R}^3$. This is a set of eight algebraic equations in seven variables. Clearly, the constraint $\vec{n}_\gamma^\top \vec{n}_\gamma = 1$ can be

replaced by $\begin{bmatrix} 0 & 0 & 1 \end{bmatrix} \vec{n}_{\bar{\gamma}} = -1$ to enforce that the plane normal faces the first camera. To get polynomial equations, we multiply the left equation by $\psi^2 = 1/\xi^2$ and the middle equation in Equation 8.74 by $\psi^3 = 1/\xi^3$ to get

$$(\mathbf{H} - \vec{u}_{\gamma'} \vec{n}_{\bar{\gamma}}^\top)^\top (\mathbf{H} - \vec{u}_{\gamma'} \vec{n}_{\bar{\gamma}}^\top) = \psi^2 \mathbf{I}, \quad |(\mathbf{H} - \vec{u}_{\gamma'} \vec{n}_{\bar{\gamma}}^\top)| = \psi^3, \quad \begin{bmatrix} 0 & 0 & 1 \end{bmatrix} \vec{n}_{\bar{\gamma}} = -1 \quad (8.75)$$

with $\vec{u}_{\gamma'} = \psi \vec{v}_{\gamma'}$. Interestingly, this system has¹ 12 solutions in general. Even more interestingly, there are only four real solutions but with only two opposite values for ψ . Taking into account

¹The following Maple [18] run demonstrates the structure of solutions to the system of equations 8.75.

Linear algebra shortcuts

```
>with(ListTools):with(LinearAlgebra):with(Groebner):
>E:=LinearAlgebra[IdentityMatrix](3):
>det:=LinearAlgebra[Determinant]:
>trn:=LinearAlgebra[Transpose]:
>M2L:=proc(M) convert(convert(M,Vector),list); end proc:
>X_:=proc(u) <<0|-u[3]|u[2]>, <u[3]|0|-u[1]>, <-u[2]|u[1]|0>> end proc:
>c2R:=c->simplify((E-X_(c)).MatrixInverse(E+X_(c))):
```

All solutions to a triangular Groebner Basis

```
>TriangularGBSolve:=proc(Eq,So)
local s, so, Si;
if nops(Eq)>0 then
Si:=[];
if nops(So)=0 then
Si:=solve([Eq[1]]);
else
for so in So do
s:=solve(subs(so, [Eq[1]]));
Si:=op(Si),op(map(f->f union so,s));
end do;
end if;
TriangularGBSolve(Eq[2..],Si);
else
So;
end if
end proc;
```

Simulate a calibrated homography

```
>R0:=c2R(RandomVector(3,generator=-10..10)):
>t0:=RandomVector(3,generator=-10..10):
>n0:=<-1,-2,-2>/3:
>s0:=3:
```

```
>H0:=s0*(R0+t0.trn(n0));
H0 :=  $\begin{bmatrix} -\frac{25}{31} & +\frac{30}{31} & +\frac{129}{31} \\ -\frac{300}{31} & -\frac{539}{31} & -\frac{560}{31} \\ \frac{84}{31} & -\frac{14}{31} & +\frac{70}{31} \end{bmatrix}$ 
```

Formulas for H and R

```
>n:=<n1,n2,n3>:
>t:=<t1,t2,t3>:
>R:=H0-t.trn(n):
>H:=R+t.trn(n):
```

Equations

```
>eq:=convert(convert(expand([op(M2L(trn(R).R-s^2*E)),det(R)-s^3,n3+1]),set),list);
eq :=  $[n3+1, 3151/31+(50/31)*t1*n1+n1^2*t1^2+(600/31)*n1*t2+n1^2*t2^2-(168/31)*n1*t3+n1^2*t3^2-s^2, 9407/31-(60/31)*t1*n2+n2^2*t1^2+(1078/31)*n2*t2+n2^2*t2^2+(28/31)*n2*t3+n2^2*t3^2-s^2, 10811/31-$ 
```

that point scales ζ, ζ' have to be positive, we get only two solutions with only one positive ψ and two corresponding solutions. Hence, the relative orientation of two calibrated cameras can be in a generic situation obtained from four coplanar points up to two solutions.

8.3 Spherical image

Consider a camera rotating around a center C and collecting n images all around such that every ray from C is captured in some image. We can choose one camera, e.g. the first one, and relate all other cameras to it as

$$\lambda_i \vec{x}_{\beta_1} = \mathbf{H}_i \vec{x}_{\beta_i}, \quad i = 1, \dots, n \quad (8.76)$$

Since all vectors \vec{x} were captured, there inevitably will appear a vector with coordinates

$$\vec{x}_{\beta_1} = \begin{bmatrix} x \\ y \\ 0 \end{bmatrix} \quad (8.77)$$

$(258/31) * t1 * n3 + n3^2 * t1^2 + (1120/31) * n3 * t2 + n3^2 * t2^2 - (140/31) * t3 * n3 + n3^2 * t3^2 - s^2, 5154/31 + (25/31) * t1 * n2 - (30/31) * t1 * n1 + n1 * n2 * t1^2 + (300/31) * n2 * t2 + (539/31) * n1 * t2 + n2 * n1 * t2^2 - (84/31) * n2 * t3 + (14/31) * n1 * t3 + n2 * n1 * t3^2, 5505/31 + (25/31) * t1 * n3 - (129/31) * t1 * n1 + n1 * n3 * t1^2 + (300/31) * n3 * t2 + (560/31) * n1 * t2 + n3 * n1 * t2^2 - (84/31) * t3 * n3 - (70/31) * n1 * t3 + n3 * n1 * t3^2, 9830/31 - (30/31) * t1 * n3 - (129/31) * t1 * n2 + n2 * n3 * t1^2 + (539/31) * n3 * t2 + (560/31) * n2 * t2 + n2 * n3 * t2^2 + (14/31) * t3 * n3 - (70/31) * n2 * t3 + n2 * n3 * t3^2, -(725/31) * t3 * n3 + (840/31) * t1 * n2 + (126/31) * n1 * t2 + (1470/31) * t1 * n1 - (1701/31) * n1 * t3 + (406/31) * n2 * t2 + (1700/31) * n2 * t3 - (70/31) * n3 * t2 - (1596/31) * t1 * n3 + 7014/31 - s^3]$

The number of solutions

```
>G:=Groebner[Basis](eq,plex(op([t1,t2,t3,n1,n2,n3,s]))):
>Id:=PolynomialIdeals[PolynomialIdeal]([op(G)]):
>print("Hilbert dimension =",PolynomialIdeals[HilbertDimension](Id));
>print("The number of solutions =",PolynomialIdeals[NumberOfSolutions](Id));
"Hilbert dimension =", 0
"The number of solutions =", 12
```

Solve it

```
>S:=TriangularGBSolve(G,[]):
and substitute the solutions to get s, R, n, t and select the real solutions only
>sRnt:=map(f->evalf(subs(f,[s,R/s,n,t/s])),S):
>select(f->foldl('and',true,op(MTM[isreal]~(f))),sRnt);
```

$$\begin{bmatrix} +3.0 & \begin{bmatrix} -0.610 & -0.220 & 0.761 \\ -0.152 & -0.910 & -0.385 \\ 0.778 & -0.350 & 0.522 \end{bmatrix} & \begin{bmatrix} -0.545 \\ -0.867 \\ -1.000 \end{bmatrix} & \begin{bmatrix} -0.626 \\ 5.640 \\ -0.230 \end{bmatrix} \end{bmatrix}$$

$$\begin{bmatrix} +3.0 & \begin{bmatrix} -0.602 & -0.344 & 0.720 \\ -0.559 & -0.462 & -0.688 \\ 0.570 & -0.817 & 0.860 \end{bmatrix} & \begin{bmatrix} -0.500 \\ -1.000 \\ -1.000 \end{bmatrix} & \begin{bmatrix} -0.667 \\ 5.330 \\ -0.667 \end{bmatrix} \end{bmatrix}$$

$$\begin{bmatrix} -3.0 & \begin{bmatrix} 0.737 & 0.421 & -0.529 \\ -0.517 & -0.153 & -0.842 \\ -0.435 & 0.894 & 0.105 \end{bmatrix} & \begin{bmatrix} -0.545 \\ -0.867 \\ -1.000 \end{bmatrix} & \begin{bmatrix} 0.858 \\ -6.860 \\ 0.858 \end{bmatrix} \end{bmatrix}$$

$$\begin{bmatrix} -3.0 & \begin{bmatrix} 0.636 & 0.411 & -0.654 \\ -0.765 & -0.809 & -0.583 \\ -0.768 & 0.421 & -0.483 \end{bmatrix} & \begin{bmatrix} -0.500 \\ -1.000 \\ -1.000 \end{bmatrix} & \begin{bmatrix} 0.734 \\ -6.600 \\ 0.270 \end{bmatrix} \end{bmatrix}$$

Such vector does not represent any point in the affine image plane π_1 of the first camera because it does not have the third coordinate equal to one. To be able to represent rays in all directions, we have to introduce *spherical image*, which is the set of all unit vectors in \mathbb{R}^3 (also called *omnidirectional image*). We sometimes use only a subset of the sphere, typically a cylinder, to capture *panoramic image*. In such a case, we can remap pixels onto such cylinder and then unwarp the cylinder into a plane. Notice however, that in such a representation, straight lines in space do not project to straight lines in images.

All equations we have developed so far work with minor modifications also for vectors with last zero coordinate. We will come back to it later when studying *projective plane* which is somewhere between the affine image plane and full spherical image.

8.4 Homography – summary

Let us summarize the findings related to homography to see where it appears.

Let us encounter one of the following situations

1. **Two images with one projection center** Let $[u, v]^\top$ and $[u', v']^\top$ be coordinates of the projections of 3D points into two images by two perspective cameras with identical projection centers;
2. **Image of a plane.** Let $[u, v]^\top$ be coordinates of 3D points all in one plane σ , w.r.t. a coordinate system in σ and $[u', v']^\top$ coordinates of their projections by a perspective cameras with projection center not in the plane σ ;
3. **Two images of a plane** Let $[u, v]^\top$ and $[u', v']^\top$ be coordinates of the projections of 3D points all in one plane σ , into two images by two perspective cameras with projection centers not in σ ;

then there holds

$$\exists \mathbf{H} \in \mathbb{R}^{3 \times 3}, \text{rank } \mathbf{H} = 3, \text{ so that } \forall [u, v]^\top \overset{\text{corr}}{\leftrightarrow} [u', v']^\top \exists \lambda \in \mathbb{R} : \lambda \begin{bmatrix} u' \\ v' \\ w' \end{bmatrix} = \mathbf{H} \begin{bmatrix} u \\ v \\ w \end{bmatrix} \quad (8.78)$$

true where $w = w' = 1$ for perspective images and may be general for spherical images.

In all three cases, coordinates of points are related by a homography.

We have used linear algebra to derive the relationship between the coordinates of image points in the above form. The homography can be also represented in a different way.

To see that, we shall eliminate λ as follows

$$\lambda \begin{bmatrix} u' \\ v' \\ 1 \end{bmatrix} = \mathbf{H} \begin{bmatrix} u \\ v \\ 1 \end{bmatrix} = \begin{bmatrix} h_{11} & h_{12} & h_{13} \\ h_{21} & h_{22} & h_{23} \\ h_{31} & h_{32} & h_{33} \end{bmatrix} \begin{bmatrix} u \\ v \\ 1 \end{bmatrix} \quad (8.79)$$

$$\lambda u' = h_{11} u + h_{12} v + h_{13} \quad (8.80)$$

$$\lambda v' = h_{21} u + h_{22} v + h_{23} \quad (8.81)$$

$$\lambda 1 = h_{31} u + h_{32} v + h_{33} \quad (8.82)$$

$$u' = \frac{h_{11} u + h_{12} v + h_{13}}{h_{31} u + h_{32} v + h_{33}} \quad (8.83)$$

$$v' = \frac{h_{21} u + h_{22} v + h_{23}}{h_{31} u + h_{32} v + h_{33}} \quad (8.84)$$

We see that mapping h obtained as

$$\begin{bmatrix} u' \\ v' \end{bmatrix} = h \left(\begin{bmatrix} u \\ v \end{bmatrix} \right) = \begin{bmatrix} \frac{h_{11} u + h_{12} v + h_{13}}{h_{31} u + h_{32} v + h_{33}} \\ \frac{h_{21} u + h_{22} v + h_{23}}{h_{31} u + h_{32} v + h_{33}} \end{bmatrix} \quad (8.85)$$

is a mapping from a subset of \mathbb{R}^2 to \mathbb{R}^2 but *it is not linear!* It contains fractions of *affine* functions.

Although we can understand the homography as a linear mapping in certain sense, it is not a linear mapping in the standard sense.

Matrix H represents a linear mapping from \mathbb{R}^3 to \mathbb{R}^3 . However, we are not interested in the individual vectors in \mathbb{R}^3 but in complete one-dimensional subspaces, which correspond to the direction vectors representing projection rays.

Notice that λ can accommodate for any change of the length of $[u \ v \ 1]^T$ (except for making it zero) since it can be split into ξ, ξ' and used as

$$\xi' \begin{bmatrix} u' \\ v' \\ 1 \end{bmatrix} = H \xi \begin{bmatrix} u \\ v \\ 1 \end{bmatrix} \quad (8.86)$$

$$\mathbf{x}' = H \mathbf{x} \quad (8.87)$$

We can now think about \mathbf{x} and \mathbf{x}' as about one-dimensional subspaces of \mathbb{R}^3 generated by \vec{x} and \vec{x}' . The “equation”²

$$\mathbf{x}' = H \mathbf{x} \quad (8.88)$$

then actually means

$$\exists \vec{x} \in \mathbf{x} \text{ and } \exists \vec{x}' \in \mathbf{x}' \text{ such that } \vec{x}' = H \vec{x} \quad (8.89)$$

Thus the homography can be seen as a mapping between one-dimensional subspaces of \mathbb{R}^3 . While \mathbb{R}^3 itself is a linear space, the set of its one-dimensional subspaces, in the way we use them, *is not* a linear space and therefore the homography is not a linear mapping although it is represented by a matrix H , which is used to multiply vectors.

It is also important to notice the true relationship between homographies and 3×3 real matrices. Any 3×3 real matrix of rank 3 represents a homography but many *different* matrices represent the same homography. Let’s see why.

²Monograph [15] very often uses “=” exactly in this sense of equality of one-dimensional subspaces.

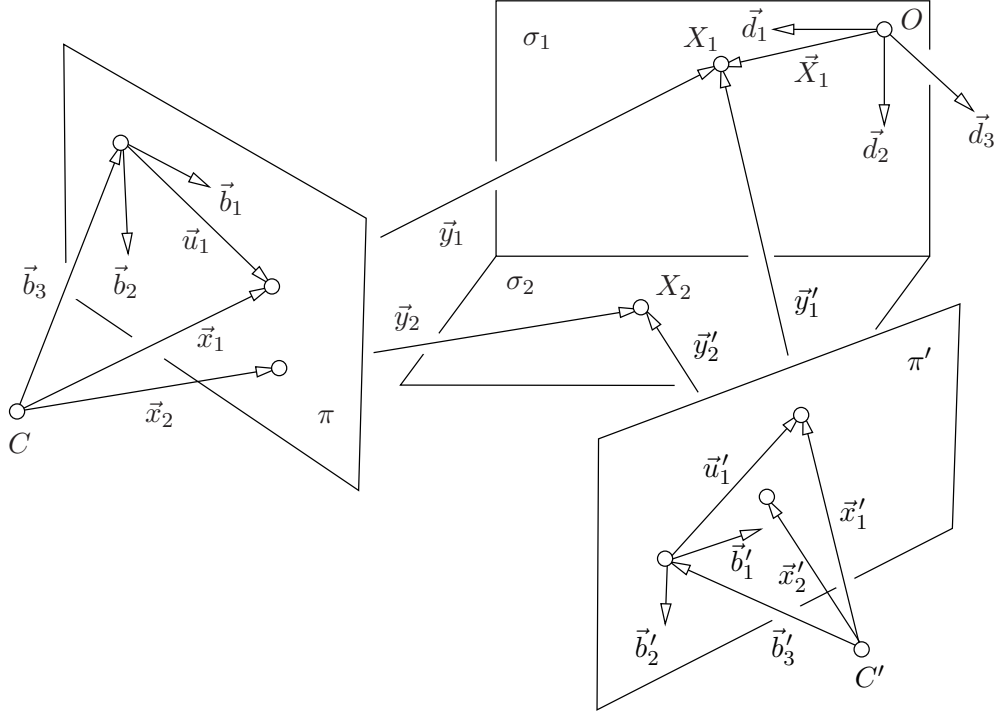

Figure 8.4: There are two planes in the scene σ_1 and σ_2 inducing two homographies H_1, H_2 between the two images.

Let us consider $H \in \mathbb{R}^{3 \times 3}$ and $G \in \mathbb{R}^{3 \times 3}$ such that $\xi H = G$ for some $\xi \neq 0$. We can write

$$\xi' \vec{x}' = H \vec{x} \quad (8.90)$$

$$\xi \xi' \vec{x}' = \xi H \vec{x} \quad (8.91)$$

$$\xi \xi' \vec{x}' = G \vec{x} \quad (8.92)$$

$$\lambda' \vec{x}' = G \vec{x} \quad (8.93)$$

We see that H and G represent the *same homography*. Indeed, two matrices related by a non-zero multiple represent the same homography. Hence, it suggests itself to associate homographies with one-dimensional subspaces of 3×3 matrices.

8.5 Constraint on the homographies of induced by two planes

Let us now consider the situation when there are two planes σ_1 and σ_2 in the scene, Figure 8.4. Then, the planes induce two homographies H_1, H_2 between the two images. We can write, Equation 8.65,

$$\begin{aligned} \tau_1' \vec{x}'_{\beta'} &= \mathbf{A}' \mathbf{A}^{-1} \left(\mathbf{I} + (\vec{C}'_{\beta} - \vec{C}_{\beta}) \frac{1}{\vec{C}_{\delta_1}(\mathbf{3})} \vec{n}_{1\beta}^{\top} \right) \vec{x}_{\beta} = H_1 \vec{x}_{\beta} \\ \tau_2' \vec{x}'_{\beta'} &= \mathbf{A}' \mathbf{A}^{-1} \left(\mathbf{I} + (\vec{C}'_{\beta} - \vec{C}_{\beta}) \frac{1}{\vec{C}_{\delta_2}(\mathbf{3})} \vec{n}_{2\beta}^{\top} \right) \vec{x}_{\beta} = H_2 \vec{x}_{\beta} \end{aligned} \quad (8.94)$$

which means that there are matrices $\mathbf{H}_1, \mathbf{H}_2$ such that for every point \vec{x}_β in image one and the corresponding point $\vec{x}'_{\beta'}$ in image two there are real τ'_1, τ'_2 such that Equations 8.94 hold true.

We are interested in finding the constraints on arbitrary representatives of the two homographies, i.e. matrices $\mathbf{G}_1 = \lambda_1 \mathbf{H}_1$ and $\mathbf{G}_2 = \lambda_2 \mathbf{H}_2$ for some real λ_1, λ_2 . We see that there follows from Equations 8.94 that

$$\begin{aligned}\lambda_1 \mathbf{G}_1 &= \mathbf{A}' \mathbf{A}^{-1} \left(\mathbf{I} + (\vec{C}'_\beta - \vec{C}_\beta) \frac{1}{\vec{C}_{\delta_1}(3)} \vec{n}_{1\beta}^\top \right) = \mathbf{A} (\mathbf{I} + \vec{t}_\beta \vec{v}_{1\beta}^\top) \\ \lambda_2 \mathbf{G}_2 &= \mathbf{A}' \mathbf{A}^{-1} \left(\mathbf{I} + (\vec{C}'_\beta - \vec{C}_\beta) \frac{1}{\vec{C}_{\delta_2}(3)} \vec{n}_{2\beta}^\top \right) = \mathbf{A} (\mathbf{I} + \vec{t}_\beta \vec{v}_{2\beta}^\top)\end{aligned}\quad (8.95)$$

and thus

$$\mathbf{G}_2^{-1} \mathbf{G}_1 = \frac{\lambda_2}{\lambda_1} (\mathbf{I} + \vec{t}_\beta \vec{v}_{2\beta}^\top)^{-1} (\mathbf{I} + \vec{t}_\beta \vec{v}_{1\beta}^\top) \quad (8.96)$$

which can be rewritten using

$$\left(\mathbf{I} + \vec{t}_\beta \vec{v}_{2\beta}^\top \right)^{-1} = \mathbf{I} - \frac{\vec{t}_\beta \vec{v}_{2\beta}^\top}{1 + \vec{v}_{2\beta}^\top \vec{t}_\beta} \quad (8.97)$$

as

$$\frac{\lambda_1}{\lambda_2} \mathbf{G}_2^{-1} \mathbf{G}_1 = \mathbf{I} - \frac{\vec{t}_\beta (\vec{v}_{1\beta}^\top - \vec{v}_{2\beta}^\top)}{1 + \vec{v}_{2\beta}^\top \vec{t}_\beta} \quad (8.98)$$

Now, we see that for $\vec{v}_{1\beta} \neq \vec{v}_{2\beta}$ there is a two-dimensional space of eigenvectors \vec{w}_β of $\mathbf{G}_2^{-1} \mathbf{G}_1$ since for every non-zero \vec{w}_β such that $(\vec{v}_{1\beta} - \vec{v}_{2\beta})^\top \vec{w}_\beta = 0$ are getting

$$\frac{\lambda_1}{\lambda_2} \mathbf{G}_2^{-1} \mathbf{G}_1 \vec{w}_\beta = \left(\mathbf{I} - \frac{\vec{t}_\beta (\vec{v}_{1\beta}^\top - \vec{v}_{2\beta}^\top)}{1 + \vec{v}_{2\beta}^\top \vec{t}_\beta} \right) \vec{w}_\beta = \vec{w}_\beta \quad (8.99)$$

We also see that \vec{t}_β is an eigenvector.

Vectors \vec{w}_β represent projections of the points on the intersection line l of planes σ_1, σ_2 into the first image. Line l is in both planes and therefore maps identically by \mathbf{H}_1 and \mathbf{H}_2 .

8.6 Computing homography from image matches

Let us turn to the computational aspect of the homography relationship between images. Our goal is to find the homography mapping from a few pairs of corresponding image points. We shall see that this problem leads to solving a system of linear equations.

8.6.1 General perspective cameras

Our goal is to find matrix \mathbf{H} in Equation 8.78 without assuming any knowledge about cameras. Let us introduce symbols for rows of homography \mathbf{H}

$$\mathbf{H} = \begin{bmatrix} \mathbf{h}_1^\top \\ \mathbf{h}_2^\top \\ \mathbf{h}_3^\top \end{bmatrix} \quad \text{and for the vector} \quad \mathbf{x} = \begin{bmatrix} u \\ v \\ 1 \end{bmatrix} \quad (8.100)$$

and rewrite the above matrix Equation 8.78 as

$$\lambda u' = \mathbf{h}_1^\top \mathbf{x} \quad (8.101)$$

$$\lambda v' = \mathbf{h}_2^\top \mathbf{x} \quad (8.102)$$

$$\lambda = \mathbf{h}_3^\top \mathbf{x} \quad (8.103)$$

Eliminate λ from the first two equations using the third one

$$(\mathbf{h}_3^\top \mathbf{x}) u' = \mathbf{h}_1^\top \mathbf{x} \quad (8.104)$$

$$(\mathbf{h}_3^\top \mathbf{x}) v' = \mathbf{h}_2^\top \mathbf{x} \quad (8.105)$$

$$(8.106)$$

move all to the left hand side and reshape it using $\mathbf{x}^\top \mathbf{y} = \mathbf{y}^\top \mathbf{x}$

$$\mathbf{x}^\top \mathbf{h}_1 - (u' \mathbf{x}^\top) \mathbf{h}_3 = 0 \quad (8.107)$$

$$\mathbf{x}^\top \mathbf{h}_2 - (v' \mathbf{x}^\top) \mathbf{h}_3 = 0 \quad (8.108)$$

$$(8.109)$$

Introduce notation

$$\mathbf{h} = [\mathbf{h}_1^\top \quad \mathbf{h}_2^\top \quad \mathbf{h}_3^\top]^\top \quad (8.110)$$

and express the above two equations in a matrix form

$$\begin{bmatrix} u & v & 1 & 0 & 0 & 0 & -u'u & -u'v & -u' \\ 0 & 0 & 0 & u & v & 1 & -v'u & -v'v & -v' \end{bmatrix} \mathbf{h} = 0 \quad (8.111)$$

Every correspondence $[u, v]^\top \overset{corr}{\leftrightarrow} [u', v']^\top$ brings two rows to a matrix

$$\begin{bmatrix} u & v & 1 & 0 & 0 & 0 & -u'u & -u'v & -u' \\ 0 & 0 & 0 & u & v & 1 & -v'u & -v'v & -v' \\ \vdots & & & & & & & & \end{bmatrix} \mathbf{h} = 0 \quad (8.112)$$

$$\mathbf{M} \quad \mathbf{h} = 0 \quad (8.113)$$

If $\xi \mathbf{G} = \mathbf{H}$, $\xi \neq 0$ then both \mathbf{G}, \mathbf{H} represent the same homography. We are therefore looking for one-dimensional subspaces of 3×3 matrices of rank 3. Each such subspace determines one homography. Also note that the zero matrix, $\mathbf{0}$, does not represent an interesting mapping.

We need therefore at least 4 correspondences in a general position to obtain rank 8 matrix \mathbf{M} . By a general position we mean that the matrix \mathbf{M} must have *rank* 8 to provide a single one-dimensional subspace of its solutions. This happens when no 3 out of the 4 points are on the same line.

Notice that \mathbf{M} can be written in the form

$$\mathbf{M} = \begin{bmatrix} u_1 & v_1 & 1 & 0 & 0 & 0 & -u'_1 u_1 & -u'_1 v_1 & -u'_1 \\ u_2 & v_2 & 1 & 0 & 0 & 0 & -u'_2 u_2 & -u'_2 v_2 & -u'_2 \\ & & & & & & \vdots & & \\ 0 & 0 & 0 & u_1 & v_1 & 1 & -v'_1 u_1 & -v'_1 v_1 & -v'_1 \\ 0 & 0 & 0 & u_2 & v_2 & 1 & -v'_2 u_2 & -v'_2 v_2 & -v'_2 \\ & & & & & & \vdots & & \end{bmatrix} \quad (8.114)$$

with indices naming different points, which can be rewritten more concisely as

$$\mathbf{M} = \begin{bmatrix} \mathbf{x}_1^\top & 0^\top & -u'_1 \mathbf{x}_1^\top \\ \mathbf{x}_2^\top & 0^\top & -u'_2 \mathbf{x}_2^\top \\ \vdots & \vdots & \vdots \\ 0^\top & \mathbf{x}_1^\top & -v'_1 \mathbf{x}_1^\top \\ 0^\top & \mathbf{x}_2^\top & -v'_2 \mathbf{x}_2^\top \\ \vdots & \vdots & \vdots \end{bmatrix} \quad (8.115)$$

with $0^\top = [0, 0, 0]$.

§ 1 A more general procedure for computing \mathbf{H} Let us next give a more general procedure for computing \mathbf{H} , which will be analogical to the general procedure for computing \mathbf{Q} in § 1.

We start from Equation 8.78

$$\lambda \mathbf{x}' = \mathbf{H} \mathbf{x} \quad (8.116)$$

with $\mathbf{x} = [u, v, w]^\top$ and $\mathbf{x}' = [u', v', w']^\top$ and follow the derivation in § 1 to get

$$\lambda \mathbf{x}' = \mathbf{H} \mathbf{x} \quad (8.117)$$

$$[\mathbf{x}']_{\times} \mathbf{H} \mathbf{x} = 0 \quad (8.118)$$

$$\mathbf{x}^\top \mathbf{H}^\top [\mathbf{x}']_{\times}^\top = 0^\top \quad (8.119)$$

$$v(\mathbf{x}^\top \mathbf{H}^\top [\mathbf{x}']_{\times}^\top) = v(0^\top) \quad (8.120)$$

$$([\mathbf{x}']_{\times} \otimes \mathbf{x}^\top) v(\mathbf{H}^\top) = v(0^\top) \quad (8.121)$$

$$\left(\begin{bmatrix} 0 & -w' & v' \\ w' & 0 & -u' \\ -v' & u' & 0 \end{bmatrix} \otimes \mathbf{x}^\top \right) v(\mathbf{H}^\top) = v(0^\top) \quad (8.122)$$

$$\begin{bmatrix} 0^\top & -w' \mathbf{x}^\top & v' \mathbf{x}^\top \\ w' \mathbf{x}^\top & 0^\top & -u' \mathbf{x}^\top \\ -v' \mathbf{x}^\top & u' \mathbf{x}^\top & 0^\top \end{bmatrix} v(\mathbf{H}^\top) = v(0^\top) \quad (8.123)$$

For more correspondences numbered by i , we then get

$$\begin{bmatrix} 0^\top & -w'_1 \mathbf{x}_1^\top & v'_1 \mathbf{x}_1^\top \\ 0^\top & -w'_2 \mathbf{x}_2^\top & v'_2 \mathbf{x}_2^\top \\ \vdots & \vdots & \vdots \\ w'_1 \mathbf{x}_1^\top & 0^\top & -u'_1 \mathbf{x}_1^\top \\ w'_2 \mathbf{x}_2^\top & 0^\top & -u'_2 \mathbf{x}_2^\top \\ \vdots & \vdots & \vdots \\ -v'_1 \mathbf{x}_1^\top & u'_1 \mathbf{x}_1^\top & 0^\top \\ -v'_2 \mathbf{x}_2^\top & u'_2 \mathbf{x}_2^\top & 0^\top \\ \vdots & \vdots & \vdots \end{bmatrix} v(\mathbf{H}^\top) = 0 \quad (8.124)$$

which is, for $w = 1$, equivalent to Equation 6.30. Notice that $v(\mathbf{H}^\top) = \mathbf{h}$ from Equation 8.113.

8.6.2 Calibrated cameras

Let us now look at some situations when cameras have constant internal calibration or are fully calibrated.

§1 Homography induced by rotating a calibrated camera This is a simple situation. Let us construct a rotation matrix representing a homography from one and half matching image points. Consider two distinct image points \mathbf{x}, \mathbf{y} in the first image that are mapped on points \mathbf{x}', \mathbf{y}' in the second image as $\begin{bmatrix} \mathbf{x}'/|\mathbf{x}'| & \mathbf{y}'/|\mathbf{y}'| \end{bmatrix} = \mathbf{R} \begin{bmatrix} \mathbf{x}/|\mathbf{x}| & \mathbf{y}/|\mathbf{y}| \end{bmatrix}$ by a rotation \mathbf{R} . We can decompose \mathbf{R} into a composition of two simple rotations $\mathbf{R} = \mathbf{R}_2 \mathbf{R}_1$ such that

$$\begin{bmatrix} \mathbf{x}'/|\mathbf{x}'| & \mathbf{y}'/|\mathbf{y}'| \end{bmatrix} = \mathbf{R}_2 \begin{bmatrix} 0 & 0 \\ 0 & \xi' \\ 1 & \psi' \end{bmatrix}, \quad \begin{bmatrix} 0 & 0 \\ 0 & \xi \\ 1 & \psi \end{bmatrix} = \mathbf{R}_1 \begin{bmatrix} \mathbf{x}/|\mathbf{x}| & \mathbf{y}/|\mathbf{y}| \end{bmatrix} \quad (8.125)$$

with ξ, ψ such that $\xi^2 + \psi^2 = \xi'^2 + \psi'^2 = 1$. Write

$$\mathbf{R}_1 = \begin{bmatrix} \mathbf{r}_{11} & \mathbf{r}_{12} & \mathbf{r}_{13} \end{bmatrix}^\top \quad \text{and} \quad \mathbf{R}_2 = \begin{bmatrix} \mathbf{r}_{21} & \mathbf{r}_{22} & \mathbf{r}_{23} \end{bmatrix} \quad (8.126)$$

to see that

$$\mathbf{r}_{11} = s_1 (\mathbf{x}/|\mathbf{x}| \times \mathbf{y}/|\mathbf{y}|) / |(\mathbf{x}/|\mathbf{x}| \times \mathbf{y}/|\mathbf{y}|)| \quad (8.127)$$

$$\mathbf{r}_{12} = (\mathbf{x}/|\mathbf{x}| \times \mathbf{r}_{11}) / |(\mathbf{x}/|\mathbf{x}| \times \mathbf{r}_{11})| \quad (8.128)$$

$$\mathbf{r}_{13} = \mathbf{r}_{11} \times \mathbf{r}_{12} \quad (8.129)$$

$$\mathbf{r}_{21} = s_2 (\mathbf{x}'/|\mathbf{x}'| \times \mathbf{y}'/|\mathbf{y}'|) / |(\mathbf{x}'/|\mathbf{x}'| \times \mathbf{y}'/|\mathbf{y}'|)| \quad (8.130)$$

$$\mathbf{r}_{22} = (\mathbf{x}'/|\mathbf{x}'| \times \mathbf{r}_{21}) / |(\mathbf{x}'/|\mathbf{x}'| \times \mathbf{r}_{21})| \quad (8.131)$$

$$\mathbf{r}_{23} = \mathbf{r}_{21} \times \mathbf{r}_{22} \quad (8.132)$$

where the signs $s_1, s_2 \in \{+1, -1\}$ are chosen to make, e.g., $\xi > 0, \xi' > 0$. Notice that this procedure sets \mathbf{R} even when vectors $\begin{bmatrix} \mathbf{x}/|\mathbf{x}| & \mathbf{y}/|\mathbf{y}| \end{bmatrix}$ can't be exactly transformed to vectors $\begin{bmatrix} \mathbf{x}'/|\mathbf{x}'| & \mathbf{y}'/|\mathbf{y}'| \end{bmatrix}$ by a rotation, which is often the case when they are estimated from noisy measurements. Nevertheless, if the error affecting the vectors is small, \mathbf{R} so obtained is still close to the true rotation between the cameras.

§2 Homography induced by rotating a camera with constant internal calibration Consider a point $\mathbf{x} = \begin{bmatrix} x & y & 1 \end{bmatrix}^\top$ in the first image that is mapped on a point $\mathbf{x}' = \begin{bmatrix} x' & y' & 1 \end{bmatrix}^\top$ in the second image by $\lambda \mathbf{x}' = \mathbf{K}^{-1} \mathbf{R} \mathbf{K} \mathbf{x}$ with rotation \mathbf{R} and a camera calibration matrix \mathbf{K} .

We have seen, Equation 8.28, that the following two equations have to be satisfied

$$\begin{aligned} 0 &= \text{trace} \mathbf{H} - (\mathbf{H}_{11} + \mathbf{H}_{22} + \mathbf{H}_{33}) \\ &= h_{11} + h_{22} + h_{33} - h_{11} h_{22} - h_{11} h_{33} + h_{12} h_{21} + h_{13} h_{31} - h_{22} h_{33} + h_{23} h_{32} \\ 1 &= |\mathbf{H}| \\ &= h_{11} h_{22} h_{33} - h_{11} h_{23} h_{32} - h_{12} h_{21} h_{33} + h_{12} h_{23} h_{31} + h_{13} h_{21} h_{32} - h_{13} h_{22} h_{31} \end{aligned} \quad (8.133)$$

with h_{ij} , $i, j = 1, 2, 3$ denoting the elements of H . It is easy to check in the Maple [18] computer algebra system³ that the Hilbert dimension [2] of the system 8.133 is equal to seven. Therefore, we will need seven independent linear equations to reduce the Hilbert dimension to zero and

³Maple [18] script analyzing the computation of a homography induced by a rotating camera with constant internal parameters. We note that some of the functions used here have been defined in previous Maple examples.

Setup the equations

```
>H:=<<h11|h12|h13>,<h21|h22|h23>,<h31|h32|h33>>:
>Heq:=[det(H)-1,simplify(det(H-E),[det(H)=1])];
>HilbertDimension(Heq);
7
```

Simulate projections

```
>K:=<<10|1|5>,<0|12|6>,<0|0|1>>:
>R1:=c2R(<1,2,3>): R2:=c2R(<3,4,5>): t:=<<2,1,3>>:
>P1:=K.<R1|-R1.t>: P2:=K.<R2|-R2.t>:
>X:=<<0|1|1|0>,<0|0|1|1>,<0|0|0|0>,<1|1|1|1>>:
>x1:=a2h(h2a(P1.X)):
>x2:=a2h(h2a(P2.X)):
>H0:=P2[..,[1,2,4]].inv(P1[..,[1,2,4]]):
```

Check eigenvalues of H0

```
e:=Eigenvalues(H0),abs~(trn(e));
```

$$\begin{bmatrix} 1 \\ \frac{77}{85} - \frac{36}{85}i \\ \frac{77}{85} + \frac{36}{85}i \end{bmatrix}, [1 \quad 1 \quad 1]$$

Add two independent linear equations per a corresponding pair of image points

```
eq:=[op(Heq), op(Flatten(map(i->M2L((X-(x2[..,i]).H.x1[..,i])[1..2]),[1,2,3,4])))];
```

$$eq := \begin{bmatrix} h_{11} + h_{22} + h_{33} - h_{11} h_{22} - h_{11} h_{33} + h_{12} h_{21} + h_{13} h_{31} - h_{22} h_{33} + h_{23} h_{32} \\ h_{11} h_{22} h_{33} - h_{11} h_{23} h_{32} - h_{12} h_{21} h_{33} + h_{12} h_{23} h_{31} + h_{13} h_{21} h_{32} - h_{13} h_{22} h_{31} - 1 \\ -\frac{22}{5} h_{21} + \frac{54252}{565} h_{31} - \frac{74}{5} h_{22} + \frac{182484}{565} h_{32} - h_{23} + \frac{2466}{113} h_{33} \\ + \frac{22}{5} h_{11} - \frac{24068}{565} h_{31} + \frac{74}{5} h_{12} - \frac{80956}{565} h_{32} + h_{13} - \frac{1094}{113} h_{33} \\ -\frac{52}{7} h_{21} + \frac{7176}{35} h_{31} - 18 h_{22} + \frac{2484}{5} h_{32} - h_{23} + \frac{138}{5} h_{33} \\ + \frac{52}{7} h_{11} - \frac{832}{7} h_{31} + 18 h_{12} - 288 h_{32} + h_{13} - 16 h_{33} \\ -\frac{23}{5} h_{21} + \frac{9522}{41} h_{31} - \frac{126}{5} h_{22} + \frac{52164}{41} h_{32} - h_{23} + \frac{2070}{41} h_{33} \\ + \frac{23}{5} h_{11} - \frac{16261}{205} h_{31} + \frac{126}{5} h_{12} - \frac{89082}{205} h_{32} + h_{13} - \frac{707}{41} h_{33} \\ -\frac{53}{35} h_{21} + \frac{130698}{2765} h_{31} - \frac{666}{35} h_{22} + \frac{1642356}{2765} h_{32} - h_{23} + \frac{2466}{79} h_{33} \\ + \frac{53}{35} h_{11} - \frac{31853}{2765} h_{31} + \frac{666}{35} h_{12} - \frac{400266}{2765} h_{32} + h_{13} - \frac{601}{79} h_{33} \end{bmatrix}$$

Solve it

```
>Basis(eq,plex(op(indets(H))));
```

$$[3825 h_{11} - 3319, 450 h_{12} - 43, 3825 h_{13} - 7337, 85 h_{21} + 36, 5 h_{22} - 4, 85 h_{23} - 522, 3825 h_{31} + 38, 450 h_{32} + 11, 3825 h_{33} - 4376]$$

We are getting one solution but we have used eight linear equations although seven linear equations should be sufficient to get a finite number of solutions. Let us use seven linear equations only.

```
>Basis(eq[1..nops(eq)-1],plex(op(indets(H))));
```

We see that we are getting a degree six polynomial in h_{33}

```
>B[1];
```

$$\begin{aligned} 1384905521719726207524518830400390625 h_{33}^6 &+ 4889332606744002799184541025140000000 h_{33}^5 - \\ 3004780464450070944458597429463562500 h_{33}^4 &- 62963310535984882573971620665889376000 h_{33}^3 - \\ 1098716737305688573847805032564563200 h_{33}^2 &+ 231760248490986847248483050694397009920 h_{33} - \\ 176966810281848547933751731455841501184 & \end{aligned}$$

and six solutions for H

thus obtain a finite number of solutions ???. We see that we can use four points to add eight independent linear equations and so obtain a single solution. However, if point measurements in images were affected by measurement noise, using all eight equations would almost surely produce an inconsistent system. Therefore, it make sense to use only seven linear equations, which give six solutions and produce six homographies conjugated to a rotation for any four (or more precisely, $3 + \frac{1}{2}$) points in two images. If the error in the measuerement is small, one of the so obtained H is close to the actual homography between the images.

§3 Homography induced by a plane observed by a moving calibrated camera Let us first consider a point $\mathbf{x} = [x \ y \ 1]^\top$ in the first image that is mapped on a point $\mathbf{x}' = [x' \ y' \ 1]^\top$ in the second image by $\lambda \mathbf{x}' = (\mathbf{R} + \mathbf{u}\mathbf{n}^\top) \mathbf{x}$ with rotation \mathbf{R} , unit real vector \mathbf{n} and a vector \mathbf{u} .

Paragraph §2 shows how to decompose a homography, represented by \mathbf{H} , between two calibrated images induced by a plane in the scene into \mathbf{R} , $\vec{t}_{\gamma'}/\vec{C}_\delta$ and $\vec{n}_{\bar{\gamma}}$. Let us now show how to estimate a decomposable \mathbf{H} directly from image data. We will parameterize rotations using the Cayley parameterization []

$$\mathbf{R}(c_1, c_2, c_3) = \begin{bmatrix} \frac{c_1^2 - c_2^2 - c_3^2 + 1}{c_1^2 + c_2^2 + c_3^2 + 1} & \frac{2(c_1 c_2 + c_3)}{c_1^2 + c_2^2 + c_3^2 + 1} & \frac{2(c_1 c_3 - c_2)}{c_1^2 + c_2^2 + c_3^2 + 1} \\ \frac{2(c_1 c_2 - c_3)}{c_1^2 + c_2^2 + c_3^2 + 1} & \frac{-c_1^2 + c_2^2 - c_3^2 + 1}{c_1^2 + c_2^2 + c_3^2 + 1} & \frac{2(c_2 c_3 + c_1)}{c_1^2 + c_2^2 + c_3^2 + 1} \\ \frac{2(c_1 c_3 + c_2)}{c_1^2 + c_2^2 + c_3^2 + 1} & \frac{2(c_2 c_3 - c_1)}{c_1^2 + c_2^2 + c_3^2 + 1} & \frac{-c_1^2 - c_2^2 + c_3^2 + 1}{c_1^2 + c_2^2 + c_3^2 + 1} \end{bmatrix} \quad (8.134)$$

for $c_1, c_2, c_3 \in \mathbb{R}$, which excludes rotations by 180° , since two perspective cameras can't look the opposite directions when seeing a non-degenerate piece of a plane in space. Similarly, we will assume that $\vec{n}_{\bar{\gamma}_3} = 1$ since the first (as well as the second) camera has to look at the plane. We are free to orient the plane normal towards the first camera to remove unnecessary ambiguity and to reduce the number of solutions to one half.

When the data is exact, we see that we are getting 11 solutions in general, out of which three

```
>S:=TriangularGBSolve(B,[]):
>dg:=Digits: eDigits:=10:
>Sr:=convert (map(s->evalf(subs(s,H)),S),rational);
>Digits:=dg:
[ [ 3319 43 7337 ], [ 27989 11116 46056 ], [ -51941 174177 213038 ]
 [ 3825 450 3825 ], [ 113075 68877 11543 ], [ 3866 144175 5423 ]
 [ -36 4/5 522 ], [ -55317 29162 62207 ], [ -40431 36210 710577 ]
 [ 85 85 ], [ 33688 29109 6739 ], [ 1690 11627 12973 ]
 [ -38 -11 4376 ], [ -4819 -3479 9932 ], [ -57914 6959 43100 ]
 [ 3825 -450 3825 ], [ 93927 -158824 7517 ], [ 70849 87760 19401 ]
 [ 40441 -20953 -69409 ], [ 91103 -63957 i -19612 + 16799 i -137213 + 23642 i ]
 [ 1236 8193 809 ], [ 21006 -17956 i -29061 + 28267 i -6863 + 1355 i ]
 [ 132430 -26276 -1327299 ], [ 178138 -43433 i -114375 + 27263 i -78611 + 135829 i ]
 [ 2457 4897 11857 ], [ 16263 -4596 i -43187 - 11331 i -2342 + 4558 i ]
 [ 72875 -5270 -94659 ], [ 15541 -5675 i 3263 - 4388 i -24252 + 122693 i ]
 [ 39356 -22337 37021 ], [ 42367 17974 i 533530 - 462787 i -8569 + 46803 i ]
 [ 91103 + 63957 i -19612 - 16799 i -137213 - 23642 i ]
 [ 21006 + 17956 i -29061 - 28267 i -6863 - 1355 i ]
 [ 178138 + 43433 i -114375 - 27263 i -78611 - 135829 i ]
 [ 16263 + 4596 i -43187 - 11331 i -2342 - 4558 i ]
 [ 15541 + 5675 i 3263 + 4388 i -24252 - 122693 i ]
 [ 42367 17974 i 533530 + 462787 i -8569 - 46803 i ]
```

Notice that the first solution is equal to the simulated homography, while the other solutions (shown only up to 10 digits precision to avoid too long expressions) are ‘artifacts’ of the formulation.

are real⁴. The ideal generated by the equations from four co-planar points is radical but it is not prime [2]. We see that the corresponding variety is a union of three irreducible varieties, each consisting of a single real point, and a component consisting of eight non-real points.

⁴Maple [18] script analyzing the computation of a homography between two calibrated images induced by a plane in a scene observed by the cameras. We note that some of the functions used here have been defined in previous Maple examples.

Constraints on a homography induced by a plane between calibrated images

```
>n:=<n1,n2,n3>:
>t:=<t1,t2,t3>:
>R:=c2R(<c1,c2,c3>):
>H:=R+t.trn(n);
H := 
$$\begin{bmatrix} \frac{c1^2-c2^2-c3^2+1}{c1^2+c2^2+c3^2+1} + t1\ n1 & 2 \frac{c1\ c2+c3}{c1^2+c2^2+c3^2+1} + t1\ n2 & 2 \frac{c1\ c3-c2}{c1^2+c2^2+c3^2+1} + t1\ n3 \\ 2 \frac{c1\ c2-c3}{c1^2+c2^2+c3^2+1} + t2\ n1 & -\frac{c1^2-c2^2+c3^2-1}{c1^2+c2^2+c3^2+1} + t2\ n2 & 2 \frac{c2\ c3+c1}{c1^2+c2^2+c3^2+1} + t2\ n3 \\ 2 \frac{c1\ c3+c2}{c1^2+c2^2+c3^2+1} + t3\ n1 & -2 \frac{-c2\ c3+c1}{c1^2+c2^2+c3^2+1} + t3\ n2 & -\frac{c1^2+c2^2-c3^2-1}{c1^2+c2^2+c3^2+1} + t3\ n3 \end{bmatrix}$$

```

Simulate projections

```
>R1:=c2R(<1,2,3>): C1:=<<2,1,3>>: P1:=<R1|-R1.C1>:
>R2:=c2R(<3,4,5>): C2:=<<2,3,1>>: P2:=<R2|-R2.C2>:
>H0:=P2[.,[1,2,4]].inv(P1[.,[1,2,4]]);
>X:=<<0|10|10|0>>,<0|0|10|10>>,<0|0|0|0 >,<1|1|1|1>>:
>x1:=a2h(h2a(P1.X)):
>x2:=a2h(h2a(P2.X)):
```

Setup equations

```
>eq:=[n3+1,op( numer(normal(Flatten(
map(i->M2L((X.(x2[.,i]).H.x1[.,i])[1..2]),[1,2,3,4])
))))]:
```

Solve them

```
>B:=Basis(eq,plex(c1,c2,c3,n1,n2,n3,t1,t2,t3)):
and analyze the ideal
>Bi:=PolynomialIdeals[PolynomialIdeal]([op(B)]):
print("Hilbert dimension =",PolynomialIdeals[HilbertDimension](Bi));
print("The number of solutions =",PolynomialIdeals[NumberOfSolutions](Bi));
print("Is radical =",PolynomialIdeals[IsRadical](Bi));
print("Is prime =",PolynomialIdeals[IsPrime](Bi));
print("Is primary =",PolynomialIdeals[IsPrimary](Bi));
print("Is maximal =",PolynomialIdeals[IsMaximal](Bi));
"Hilbert dimension =", 0
"The number of solutions =", 11
"Is radical =", true
"Is prime =", false
"Is primary =", false
"Is maximal =", false
```

We see that the ideal can be obtained as an intersection of four prime ideals

```
>Bd:=PolynomialIdeals[PrimeDecomposition](Bi):
BB:=map(i->Basis(i,plex(c1,c2,c3,n1,n2,n3,t1,t2,t3)),[Bd]):
map(b->[HilbertDimension(b),
PolynomialIdeals[NumberOfSolutions](PolynomialIdeals[PolynomialIdeal](b))],
BB);
```

```
[[0, 1], [0, 1], [0, 1], [0, 8]]
```

which consists of single and eight points, respectively. There are 11 solutions for t3

```
>PolyVarMonomials([B[1]],plex(op(indets(B[1]))));
[t311,t310,t39,t38,t37,t36,t35,t34,t33,t32,t3,1]
```

Let us get solutions to all variables

```
>S:=TriangularGBSolve(B,[]): nops(S);
11
```

We also see that for small noise, one of the four solutions is reasonably close to the true simulated solution.

```

>S:=TriangularGBSolve(B,[]): nops(S); map(f->simplify(eval(B,f)),S);
12
out of which four are real
>sH:=map(f->evalf([subs(f,H),subs(f,R),subs(f,n),subs(f,t)]),S):
>sH:=select(f->MTM[isreal](f[1]),sH): nops(sH);
4
Let's compare them to the simulation.
>[evalf[3](H0),evalf[3](R0),evalf[3](-n0/n0[3]),evalf[3](-t0*n0[3])];
[[ [ 0.969  0.408  0.235 ] [ 0.948  0.261  0.183 ] [ -0.400 ] [ -0.052 ] ]
 [ -0.413  0.148 -0.013 ] [ -0.303  0.916  0.261 ] [ -2.800 ] [ 0.274 ] ]
 [ -0.042  0.099  1.090 ] [ -0.099 -0.303  0.948 ] [ -1.000 ] [ -0.144 ] ] ]
>map(f->print(evalf[3](f)),sH):
[[ [ -0.969 -0.410 -0.237 ] [ -0.833  0.543  0.105 ] [ -0.398 ] [ 0.342 ] ]
 [ 0.413 -0.147  0.014 ] [ 0.543  0.767  0.342 ] [ -2.790 ] [ 0.328 ] ]
 [ 0.042 -0.099 -1.090 ] [ 0.105  0.342 -0.934 ] [ -1.000 ] [ 0.158 ] ] ]
[[ [ -0.969 -0.410 -0.237 ] [ -0.820 -0.563 -0.104 ] [ -1.120 ] [ 0.133 ] ]
 [ 0.413 -0.147  0.014 ] [ -0.358  0.646 -0.674 ] [ 1.150 ] [ -0.688 ] ]
 [ 0.042 -0.099 -1.090 ] [ 0.446 -0.516 -0.731 ] [ -1.000 ] [ 0.361 ] ] ]
[[ [ 0.969  0.410  0.237 ] [ 0.948  0.261  0.183 ] [ -0.398 ] [ -0.053 ] ]
 [ -0.413  0.147 -0.014 ] [ -0.303  0.916  0.262 ] [ -2.790 ] [ 0.276 ] ]
 [ -0.042  0.099  1.090 ] [ -0.099 -0.304  0.948 ] [ -1.000 ] [ -0.145 ] ] ]
[[ [ 0.969  0.410  0.237 ] [ 0.568  0.803 -0.105 ] [ -1.120 ] [ -0.341 ] ]
 [ -0.413  0.147 -0.014 ] [ -0.780  0.525 -0.342 ] [ 1.150 ] [ -0.328 ] ]
 [ -0.042  0.099  1.090 ] [ -0.219 -0.282  0.934 ] [ -1.000 ] [ -0.158 ] ] ]

```

We see that the third solution corresponds to the simulation.

9 Projective plane

9.1 Motivation – perspective projection in affine space

§1 **Geometric model of perspective projection in affine space** The perspective projection of a point X by a camera with projection center C can be obtained geometrically in 3D affine space by taking all lines passing through the points C and X and finding the intersections with the (affine) image plane π .

Three different situations may arise, Figure 9.1.

1. If $X = C$, then there is an infinite number of lines passing through $C = X$, which intersect π in all its points, and therefore the projection of X contains the whole plane π .
2. If point $Y \neq C$ lies in the plane σ , which is parallel to π and passing through C , then the line passing through C and Y (which there is exactly one) *does not intersect* the projection plane π , and therefore, the projection of X is empty.
3. If X does not lie in the plane σ , then there is exactly one line passing through points C and X and this line intersects the projection plane π in exactly one point x . Hence the projection of X contains exactly one point x .

Let us compare this affine geometrical model of the perspective projection with the algebraic model of the perspective projection, which we have developed before.

§2 **Algebraic model of perspective projection in affine space** The projection \vec{x}_β of \vec{X}_δ by a perspective camera with image projection matrix

$$P_\beta = \left[\mathbf{A} \mid -\mathbf{A} \vec{C}_\delta \right] \quad (9.1)$$

is

$$\eta \vec{x}_\beta = \left[\mathbf{A} \mid -\mathbf{A} \vec{C}_\delta \right] \begin{bmatrix} \vec{X}_\delta \\ 1 \end{bmatrix} \quad (9.2)$$

for some $\eta \in \mathbb{R}$.

We shall analyze the three situations, which arise with the geometrical model of affine projection.

1. If $X = C$, then

$$\eta \vec{x}_\beta = \left[\mathbf{A} \mid -\mathbf{A} \vec{C}_\delta \right] \begin{bmatrix} \vec{C}_\delta \\ 1 \end{bmatrix} = \vec{0} \quad (9.3)$$

i.e. we obtain the zero vector. What does it say about \vec{x}_β ? Clearly, \vec{x}_β can be *completely arbitrary* (even the zero vector) when we set $\eta = 0$. Alternatively, we can choose $\eta \neq 0$ and thus enforce $\vec{x}_\beta = \vec{0}$. Both choices are possible. We shall use the latter one since we will see that it better fits the other cases. We will use $\vec{x}_\beta = \vec{0}$ to (somewhat strangely) represent all non-zero vectors in \mathbb{R}^3 .

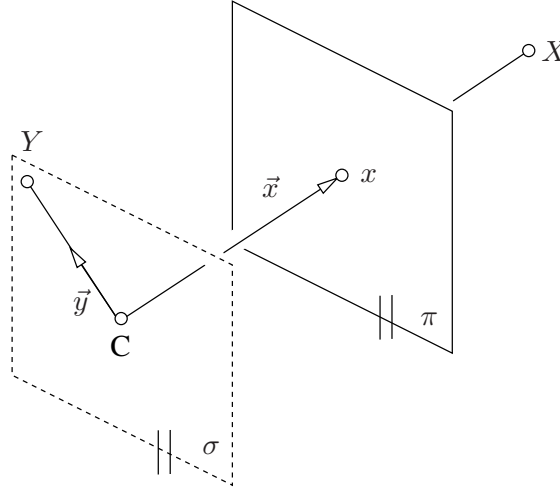

Figure 9.1: Geometric model of perspective projection in affine space. Point C has infinite (i.e. not unique) projection, point X has exactly one projection x . Point Y has no projection.

2. If point $Y \neq C$ lies in the plane σ , then

$$\eta \vec{x}_\beta = \left[\mathbf{A} \mid -\mathbf{A} \vec{C}_\delta \right] \begin{bmatrix} \vec{Y}_\delta \\ 1 \end{bmatrix} = \mathbf{A} (\vec{Y}_\delta - \vec{C}_\delta) \quad (9.4)$$

which, taking into account $\text{rank } \mathbf{A} = 3$, implies

$$\eta \mathbf{A}^{-1} \vec{x}_\beta = \vec{Y}_\delta - \vec{C}_\delta \quad (9.5)$$

Matrix \mathbf{A}^{-1} transforms \vec{x}_β into \vec{x}_δ and therefore its columns

$$\mathbf{A}^{-1} = \left[\vec{b}_{1\delta} \quad \vec{b}_{2\delta} \quad \vec{b}_{3\delta} \right] \quad (9.6)$$

are the basic vectors of the camera coordinate system in the world basis δ . Hence

$$\eta \left[\vec{b}_{1\delta} \quad \vec{b}_{2\delta} \quad \vec{b}_{3\delta} \right] \vec{x}_\beta = \vec{Y}_\delta - \vec{C}_\delta \quad (9.7)$$

which means that vector $\vec{Y}_\delta - \vec{C}_\delta$ can be written as a linear combination of the camera coordinate system basic vectors

$$\eta p \vec{b}_{1\delta} + \eta q \vec{b}_{2\delta} + \eta r \vec{b}_{3\delta} = \vec{Y}_\delta - \vec{C}_\delta \quad (9.8)$$

with $p, q, r \in \mathbb{R}$. Now, since Y lies in a plane parallel to π , vector $\vec{Y}_\delta - \vec{C}_\delta$ can be written as a linear combination of the first two basic vectors of the camera coordinate system, and therefore $r = 0$, i.e.

$$\vec{x}_\beta = \begin{bmatrix} p \\ q \\ 0 \end{bmatrix} \quad (9.9)$$

We also see that $\eta \neq 0$ since otherwise we would get the zero vector on the left but that would correspond to $Y = C$, which we have excluded.

Table 9.1: Comparison of the geometrical and algebraic projection models in affine space.

Point position	Projection	
	Geometrical model in aff. space	Algebraic model in aff. space
$X \notin \sigma$	one point of π	$\eta \neq 0, \vec{x}_\beta = \begin{bmatrix} u \\ v \\ 1 \end{bmatrix}, (\vec{x}_\beta \neq \vec{0})$
$C \neq X \in \sigma$	no point	$\eta \neq 0, \vec{x}_\beta = \begin{bmatrix} u \\ v \\ 0 \end{bmatrix}, \vec{x}_\beta \neq \vec{0}$
$X = C$	all points of π	$\eta \neq 0, \vec{x}_\beta = \vec{0}$

3. If X does not lie in the plane σ , then the coefficient $r \in \mathbb{R}$ in the linear combination

$$\eta \mathbf{A}^{-1} \vec{x}_\beta = \vec{X}_\delta - \vec{C}_\delta \quad (9.10)$$

$$\eta p \vec{b}_{1\delta} + \eta q \vec{b}_{2\delta} + \eta r \vec{b}_{3\delta} = \vec{X}_\delta - \vec{C}_\delta \quad (9.11)$$

is non-zero. In that case we can write

$$\eta \begin{bmatrix} p \\ q \\ r \end{bmatrix} = \mathbf{A} (\vec{X}_\delta - \vec{C}_\delta) \quad (9.12)$$

$$(\eta r) \begin{bmatrix} \frac{p}{r} \\ \frac{q}{r} \\ 1 \end{bmatrix} = \mathbf{A} (\vec{X}_\delta - \vec{C}_\delta) \quad (9.13)$$

$$\eta' \begin{bmatrix} u \\ v \\ 1 \end{bmatrix} = \mathbf{A} (\vec{X}_\delta - \vec{C}_\delta) \quad (9.14)$$

As in the case two, $\eta \neq 0$ since otherwise we would get the zero vector on the left and that would correspond to $X = C$, which we have excluded.

The comparison of the two models of perspective projection, Table 9.1 shows that

1. We can always assume $\eta \neq 0$.
2. The “projection” of C is represented by the zero vector while the projections of all other points are represented by non-zero vectors.
3. The algebraic projection model can represent projections of all points in the affine space.
4. The geometrical projection model is less capable than the algebraic projection model since it can’t model the projection of points in σ different from C .

The previous analysis clearly shows that the affine geometrical model of the perspective projection is somewhat deficient. It can’t model projections of some points in the space. This

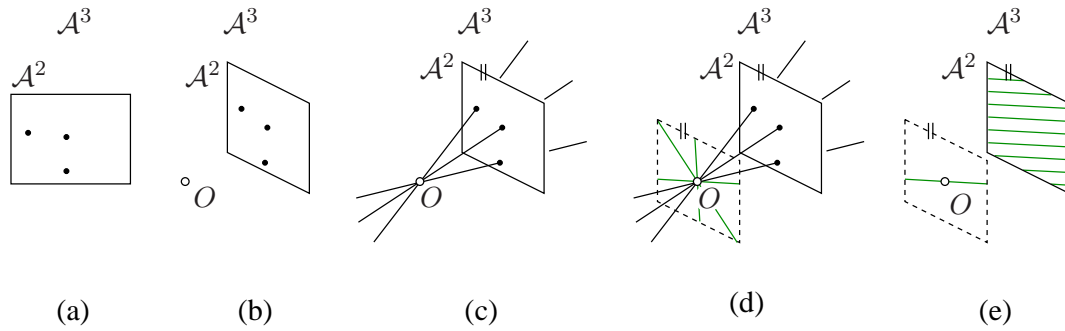

Figure 9.2: (a) Two dimensional affine plane \mathcal{A}^2 can be (b) embedded in the three dimensional affine space \mathcal{A}^3 . There is a point $O \in \mathcal{A}^3$, $O \notin \mathcal{A}^2$. (c) For each point X in \mathcal{A}^2 , there is exactly one line through X and O in \mathcal{A}^3 . (d) There is exactly one pencil of lines through O , which do not correspond to any point in \mathcal{A}^2 , in \mathcal{A}^3 . (e) Each line in the pencil corresponds to a set of parallel lines with the same direction in \mathcal{A}^2 .

deficiency leads to inventing a generalized model of the geometry around us in order to model the perspective projection completely by intersections of geometrical entities. This generalization of the affine space is called the *projective space*.

Let us look at the most important projective space, which is the *projective plane*. We shall first develop a concrete projective plane by improving the affine plane exactly as much as necessary to achieve what we want, i.e. to be able to distinguish projections of all points in the space. In fact, this will be extremely easy since we have already done all the work, and we only need to “upgrade” the notion of point, line, intersection and join (i.e. making the line from two distinct points). Later, we shall observe that such an “upgrade” will also lead to an interesting simplification and generalization of the principles of geometry.

9.2 Real projective plane

9.2.1 Geometrical model of the real projective plane

A real affine plane \mathcal{A}^2 can be imagined as a subset of a real affine space \mathcal{A}^3 , Figure 9.2. There is a point O in \mathcal{A}^3 , which is not in \mathcal{A}^2 . For each point X in \mathcal{A}^2 , there is exactly one line in \mathcal{A}^3 , which passes through X and O . Now, there is a set of lines in \mathcal{A}^3 , which pass through O but do not pass through any point of \mathcal{A}^2 . This is the set of lines parallel to \mathcal{A}^2 that pass through O . These lines fill the plane of \mathcal{A}^3 , which is parallel to \mathcal{A}^2 and which contains the point O .

The set of all lines in \mathcal{A}^3 passing through O will be called the *real projective plane* and denoted as \mathbb{P}^2 . The lines of \mathcal{A}^3 passing through O will be called the *points of the real projective plane*.¹

The lines in \mathcal{A}^3 passing through O , which intersect \mathcal{A}^2 , are in one-to-one correspondence with points in the affine plane \mathcal{A}^2 and hence will be called the *affine points of the projective plane*² of

¹The previous definition can be given without referring to any affine plane. We can take a point O in \mathcal{A}^3 and the set of all lines in \mathcal{A}^3 passing through O and call it a projective plane. In the above example, however, we have obtained the projective plane as an extension of a given affine plane \mathcal{A}^2 . In such a case, we can distinguish two sets of points – affine points and ideal points – in the projective plane.

²Vlastní body in Czech. Finite points in [15].

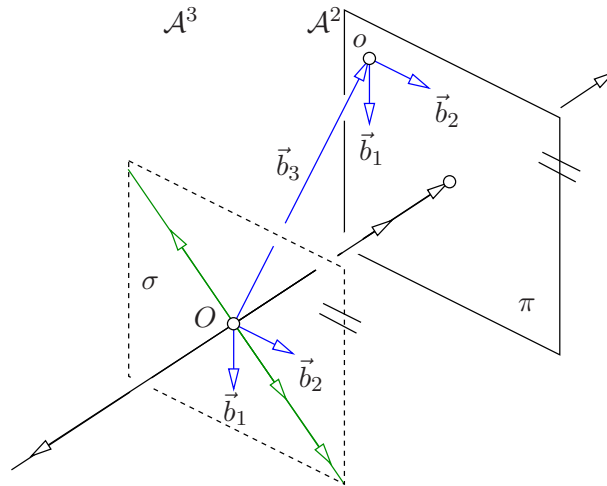

Figure 9.3: Algebraic model of the real projective plane.

the projective plane. The set of lines in \mathcal{A}^3 passing through O , which do not intersect \mathcal{A}^2 , are the “additional” points of the projective plane and will be called the *ideal points of the projective plane*^{3,4}.

To each ideal point P (i.e. a line l of \mathcal{A}^3 through O parallel to \mathcal{A}^2), there corresponds exactly one set of parallel lines in \mathcal{A}^2 which are parallel to l in \mathcal{A}^3 . Different sets of parallel lines in \mathcal{A}^2 are distinguished by their direction. In this sense, ideal points correspond to directions in \mathcal{A}^2 and can also be understood as points where parallel lines of \mathcal{A}^2 intersect. Notice that the parallel lines of \mathcal{A}^2 do not intersect in \mathcal{A}^2 , because P is not in \mathcal{A}^2 , but they intersect in the real projective plane obtained as the extension of \mathcal{A}^2 .

9.2.2 Algebraic model of the real projective plane

We shall now move from the geometrical model in \mathcal{A}^3 to an algebraic model in \mathbb{R}^3 which allows us to do computations.

Let us choose a coordinate system $(O, \vec{b}_1, \vec{b}_2, \vec{b}_3)$ in \mathcal{A}^3 with the origin in O , with basic vectors \vec{b}_1, \vec{b}_2 from the coordinate system $(o, \vec{b}_1, \vec{b}_2)$ in \mathcal{A}^2 and with $\vec{b}_3 = \varphi(O, o)$, Figure 9.3.

Lines in \mathcal{A}^3 , which pass through O , correspond to one-dimensional subspaces of \mathbb{R}^3 and therefore, in \mathbb{R}^3 , points of the real projective plane will be represented by one-dimensional subspaces.

The *real projective plane* is the set of all one-dimensional subspaces of \mathbb{R}^3 .

The affine plane is a subset of the set of all one-dimensional subspaces of \mathbb{R}^3 , which we obtain after removing all one-dimensional subspaces that lie in a two-dimensional subspace of \mathbb{R}^3 .

There are (infinitely) many possible choices of sets of one-dimensional subspaces which can

³Nevlastní body in Czech. Points at infinity in [15].

⁴Notice that words “point” and “line” actually need to be accompanied by adjectives for the above to make sense because lines of \mathcal{A}^3 become points of \mathcal{A}^2 . Also notice that this division of the points of the projective plane makes sense only when we start with a given affine plane or when we start with a projective plane and select one plane of lines in \mathcal{A}^3 as the set of ideal points.

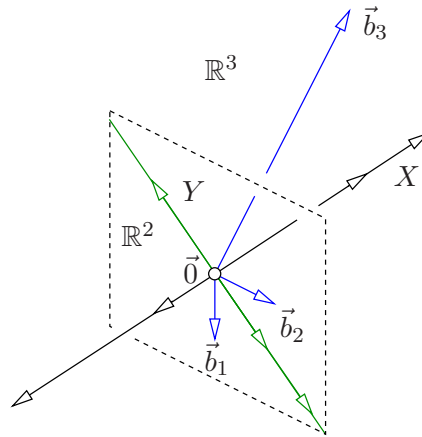

Figure 9.4: Points of the real projective plane are represented by one-dimensional subspaces of \mathbb{R}^3 . One selected two-dimensional affine subspace determines the ideal points.

model the affine plane within the real projective plane. The choice of a particular subset, which will model a concrete affine plane, can be realized by a choice of a basis in \mathbb{R}^3 .

Let us select a basis $\beta = (\vec{b}_1, \vec{b}_2, \vec{b}_3)$ of \mathbb{R}^3 . Then, all the one-dimensional subspaces generated by vectors

$$\vec{x}_\beta = \begin{bmatrix} x \\ y \\ 1 \end{bmatrix} \quad x, y \in \mathbb{R} \quad (9.15)$$

will represent affine points, point X in Figure 9.4, and all the one-dimensional subspaces generated by vectors

$$\vec{x}_\beta = \begin{bmatrix} x \\ y \\ 0 \end{bmatrix} \quad x, y \in \mathbb{R}, \quad x \neq 0 \text{ or } y \neq 0 \quad (9.16)$$

will represent the ideal points, e.g. point Y in Figure 9.4.

It is clear that the affine points are in one-to-one correspondence with all points in a two-dimensional affine space (plane) and the ideal points are exactly what we need to add to the affine points to get all one-dimensional subspaces of \mathbb{R}^3 .

9.2.3 Lines of the real projective plane

Let us look at lines now. Lines, e.g. l in Figure 9.5, in the affine plane contain points represented by one-dimensional subspaces generated, e.g., by \vec{x} and \vec{y} . This set of one-dimensional subspaces of points on l fills almost a complete two-dimensional subspace of \mathbb{R}^3 with the exception of one one-dimensional subspace, generated by \vec{z} , which represents an ideal point. After adding the subspace generated by \vec{z} to the set of all one-dimensional subspaces representing points on l , we completely fill a two-dimensional subspace of \mathbb{R}^3 , which hence corresponds to the *projective completion of the affine line l* , which we will further call line, too.

Hence, in the real projective plane, *lines correspond to two-dimensional subspaces of \mathbb{R}^3* .

We would like to do calculations with lines as we do calculations with points. Let us develop a convenient representation of lines now. A straightforward way how to represent a

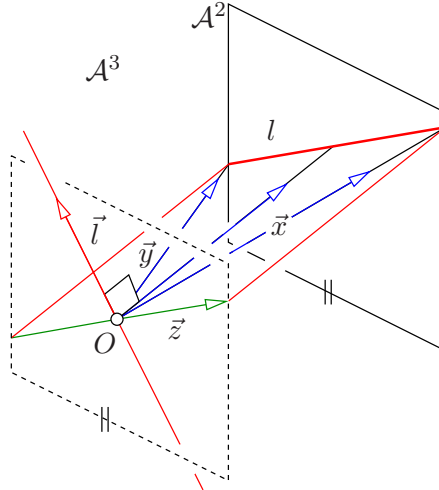

Figure 9.5: Lines of the real projective plane correspond to two-dimensional subspaces of \mathbb{R}^3 but can be also represented by one-dimensional subspaces of \mathbb{R}^3 .

two-dimensional subspace in \mathbb{R}^3 is to select a basis (i.e. two linearly independent vectors) of the subspace, e.g. \vec{x} and \vec{y} for the line l . There are many ways how to choose a basis and therefore the representation is far from unique. Moreover, having two bases, it is not apparent whether they represent the same subspace.

For instance, two pairs of linearly independent vectors (\vec{x}_1, \vec{y}_1) and (\vec{x}_2, \vec{y}_2) represent the same line if and only if they generate the same two-dimensional subspace. To verify that, we, for instance, may check whether

$$\text{rank} \begin{bmatrix} \vec{x}_{1\beta} & \vec{y}_{1\beta} & \vec{x}_{2\beta} & \vec{y}_{2\beta} \end{bmatrix} = 2 \quad (9.17)$$

where we write all the four vectors $\vec{x}_1, \vec{y}_1, \vec{x}_2, \vec{y}_2$ w.r.t. a basis β of \mathbb{R}^3 .

Yet, there is another quite convenient way how to represent a two dimensional subspace in \mathbb{R}^3 . Since $3 = 2 + 1$, we can find for each two-dimensional subspace, specified by a basis (\vec{x}, \vec{y}) , exactly one one-dimensional subspace of the three-dimensional dual linear space. Call the basis of this new one-dimensional subspace \vec{l} . Then there holds

$$\vec{l}_\beta^\top \begin{bmatrix} \vec{x}_\beta & \vec{y}_\beta \end{bmatrix} = 0 \quad (9.18)$$

where \vec{l}_β is the dual basis to β . Therefore, we can represent lines in the real projective plane by one-dimensional subspaces in this way.

We have developed an interesting representation of points and lines where both points and lines are represented by one-dimensional subspaces of \mathbb{R}^3 . Points are represented by one-dimensional subspaces of $V = \mathbb{R}^3$, which is connected by φ to the three-dimensional space \mathcal{A}^3 of the geometrical model of the real projective plane. The lines are represented by one-dimensional subspaces of the space \bar{V} , which is the space dual to V . Using the basis $\bar{\beta}$ in \bar{V} , which is dual to basis β in V , the coordinates \vec{l}_β as well as coordinates of \vec{x}_β become vectors in \mathbb{R}^3 which satisfy Equation 9.18.

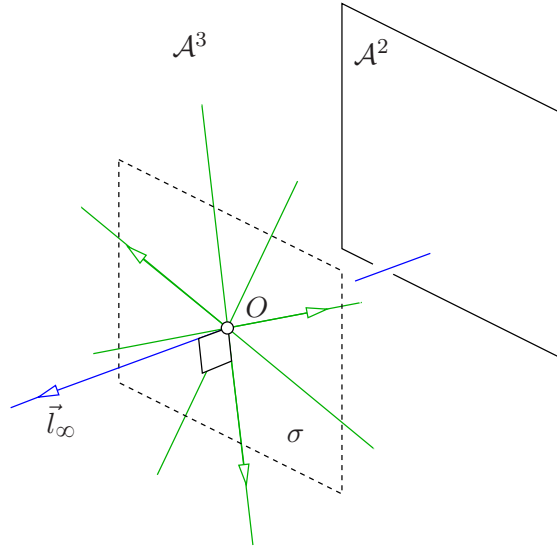

Figure 9.6: The ideal line is the set of all projective points (i.e. all lines of \mathcal{A}^3 through C , which have no intersection with \mathcal{A}^2). It is a plane σ . There is exactly one, which is perpendicular to sigma, which is generated by vector l_∞ .

The line of \mathcal{A}^3 generated by \vec{l} in Figure 9.5 is shown as perpendicular⁵ to the plane generated by \vec{x} , \vec{y} . Indeed, in the geometrical model of the real projective plane, we can use the notion of perpendicularity to uniquely construct the (perpendicular) line to the plane corresponding to l in \mathcal{A}^2 .

9.2.4 Ideal line

The set of all one-dimensional subspaces of \mathbb{R}^3 , which do not correspond to points in the affine plane, i.e. the set of all ideal points, forms itself a two-dimensional subspace of \mathbb{R}^3 and hence a line in the projective plane, which is not in the affine plane. It is the *ideal line*⁶ of the projective plane associated with the selected affine plane in that projective plane. It is represented by vector \vec{l}_∞ in Figure 9.6.

For each affine plane, there is exactly one ideal line (a two-dimensional subspace of \mathbb{R}^3). Conversely, by selecting one line in a projective plane (i.e. one two-dimensional subspace of \mathbb{R}^3) the associated affine plane is determined as the set of all points (one-dimensional subspaces of \mathbb{R}^3) which are not contained in the selected ideal line (two-dimensional subspace).

9.2.5 Homogeneous coordinates

Once a coordinate system is fixed in an affine plane, every point of the affine plane has *unique* coordinates, which are the coordinates of its vector in the basis of the coordinate system.

⁵In \mathcal{A}^3 , line and plane are perpendicular when they contain the right angle. The right angle is one quarter of a circle.

⁶Nevlastní přímka in Czech, line at infinity in [15].

A point in a real projective plane is represented by a one-dimensional subspace of \mathbb{R}^3 . One-dimensional subspaces are represented by their bases consisting of a single non-zero vector. There are infinitely many bases representing the same one-dimensional subspace. Two basic vectors of the same one-dimensional subspace are related by a non-zero multiple.

Hence, when talking about coordinates of a point in the projective space, we actually talk about coordinates of a particular basic vector of the one-dimensional subspace that represents the point.

For instance, vectors

$$\begin{bmatrix} 1 \\ 0 \\ 1 \end{bmatrix} \quad \text{and} \quad \begin{bmatrix} 2 \\ 0 \\ 2 \end{bmatrix} \tag{9.19}$$

are basic vectors of the same one-dimensional subspace since they are related by a non-zero multiple. These are two different “coordinates” of the same point in the real projective plane.

Hence, the “coordinates” of a point in the real projective plane are not unique. This is so radically departing from the fundamental property of coordinates, their uniqueness, that it deserves a new name. To distinguish the coordinates of a point in the affine plane, which are unique, from the “coordinates” of a point in the projective plane, which are not unique, we shall introduce new name *homogeneous coordinates*.

Homogeneous coordinates of a point in the real projective plane are the coordinates of a basic vector of the one-dimensional subspace, which represents the point.

Homogeneous coordinates of a line in the real projective plane are the coordinates of a basic vector of the one-dimensional subspace, which represents the line.

A point in an affine plane can be represented by affine as well as by homogeneous coordinates. Let us see the relationship between the two.

Let us have a point X in a two-dimensional real affine plane, which is represented by coordinates

$$\begin{bmatrix} x \\ y \end{bmatrix} \tag{9.20}$$

By extending the real affine plane to the real projective plane with the ideal line identified with the two-dimensional subspace $z = 0$, we can represent point X by a one-dimensional subspace of \mathbb{R}^3 generated by its basic vector

$$\begin{bmatrix} x \\ y \\ 1 \end{bmatrix} \tag{9.21}$$

Thus, X has affine coordinates $[x \ y]^\top$ and homogeneous coordinates $[u \ v \ w]^\top$, where $u = \lambda x$, $v = \lambda y$, and $w = \lambda 1$ for some $\lambda \in \mathbb{R}$, $\lambda \neq 0$.

Ideal points do not have affine coordinates. Their homogeneous coordinates are

$$[x \ y \ 0]^\top \tag{9.22}$$

where $x, y \in \mathbb{R}$ and either $x \neq 0$ or $y \neq 0$.

The zero vector $\vec{0}$ is not a basis of any one-dimensional space and thus represents neither a point nor a line.

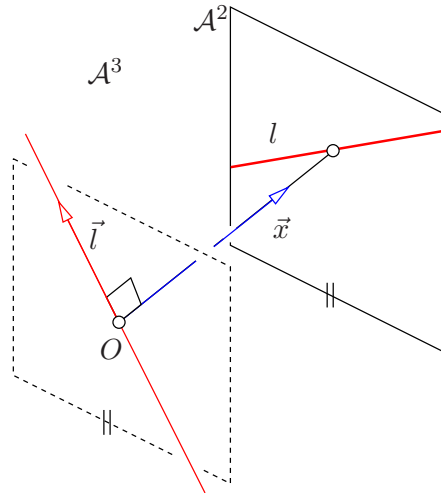

Figure 9.7: A point x is incident with a line l if and only if it can generate the line with another point y . Lines in \mathcal{A}^3 representing the point and the line are perpendicular to each other.

9.2.6 Incidence of points and lines

We say that a point x is incident with line l if and only if it can generate the line with another point y , Figure 9.7. In the representation of subspaces of \mathbb{R}^3 , it means that

$$\vec{l}_\beta^\top \vec{x}_\beta = 0 \quad (9.23)$$

This means that the one-dimensional subspace of \mathbb{R}^3 representing the line is orthogonal to the one-dimensional subspace of \mathbb{R}^3 representing the point w.r.t. the standard (Euclidean) scalar product. In the geometrical model of the real projective plane it means that the line of \mathcal{A}^3 representing x is perpendicular to line of \mathcal{A}^3 representing l .

Let us write explicitly the coordinates of the bases generating the one-dimensional subspaces as

$$\vec{x}_\beta = \begin{bmatrix} x \\ y \\ z \end{bmatrix} \quad \vec{l}_\beta = \begin{bmatrix} a \\ b \\ c \end{bmatrix}$$

then we get

$$ax + by + cz = 0$$

and for affine points represented with $z = 1$ this formula reduces to

$$ax + by + c = 0$$

which is the familiar equation of a line in the two dimensional real affine plane.

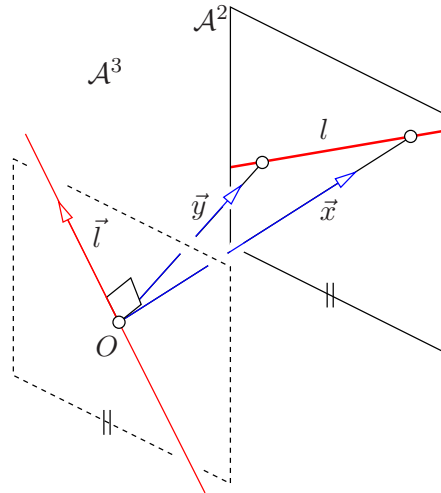

Figure 9.8: The join of two distinct points is the unique line passing through them.

9.2.7 Join of points

Every two distinct points x and y in the real projective plane are incident with exactly one line l . The *join* of two distinct points is the unique line passing through them.

In the real projective plane, two distinct points are represented by two different one-dimensional subspaces with bases \vec{x} and \vec{y} .

The homogeneous coordinates of this line, i.e. the coordinates of the basic vectors of the one-dimensional subspace representing the line, can be obtained by solving the following system of homogeneous equations for coordinates of the vector \vec{l}

$$\vec{l}_\beta^\top \vec{x}_\beta = 0 \quad (9.24)$$

$$\vec{l}_\beta^\top \vec{y}_\beta = 0 \quad (9.25)$$

w.r.t. β and $\bar{\beta}$ in \mathbb{R}^3 . The set of solutions forms the one-dimensional subspace that represents the line l .

We have seen in Section 2.3 that vector \vec{l}_β can be conveniently constructed by the vector product as

$$\vec{l}_\beta = \vec{x}_\beta \times \vec{y}_\beta \quad (9.26)$$

Notice, that *in the real projective plane as well as in the real affine plane, there is exactly one line incident with two distinct points.*

9.2.8 Meet of lines

Every two distinct lines k and l in a projective plane are incident exactly to one point x . The *meet* of two distinct lines is the unique point incident with them.

In the real projective plane, two distinct lines are represented by two different one-dimensional subspaces with bases \vec{k} and \vec{l} .

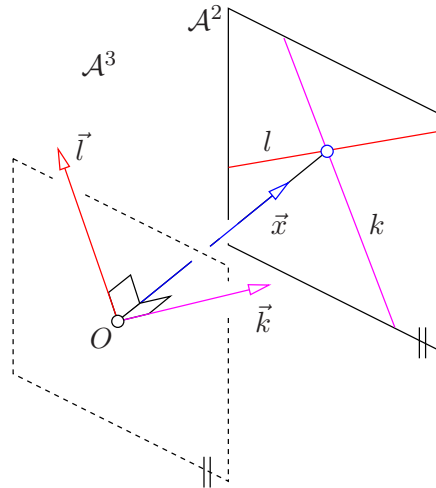

Figure 9.9: The meet of two distinct lines is the unique point incident with them.

The homogeneous coordinates of this point, i.e. the coordinates of the vectors in the one-dimensional subspace representing the point, can be obtained by solving the following system of homogeneous equations for coordinates of the vector \vec{x} w.r.t. β in \mathbb{R}^3

$$\begin{aligned}\vec{k}_\beta^\top \vec{x}_\beta &= 0 \\ \vec{l}_\beta^\top \vec{x}_\beta &= 0\end{aligned}$$

The set of solutions forms the one-dimensional subspace that represents point x . To get one basic vector in the subspace, we may again employ the vector product in \mathbb{R}^3 and compute

$$\vec{x}_\beta = \vec{k}_\beta \times \vec{l}_\beta$$

Notice, that *in the real projective plane there is exactly one point incident to two distinct lines.*

This is not true in an affine plane because there are (parallel) lines that have no point in common!

9.3 Line coordinates under homography

Let us now investigate the behavior of homogeneous coordinates of lines in projective plane mapped by a homography.

Let us have two points represented by vectors $\vec{x}_\beta, \vec{y}_\beta$. We now map the points, represented by vectors $\vec{x}_\beta, \vec{y}_\beta$, by a homography, represented by matrix H , to points represented by vectors $\vec{x}'_{\beta'}, \vec{y}'_{\beta'}$, such that there are $\lambda_1, \lambda_2 \in \mathbb{R}, \lambda_1 \lambda_2 \neq 0$

$$\lambda_1 \vec{x}'_{\beta'} = H \vec{x}_\beta \tag{9.27}$$

$$\lambda_2 \vec{y}'_{\beta'} = H \vec{y}_\beta \tag{9.28}$$

Homogeneous coordinates \vec{p}_{β} of the line passing through points represented by \vec{x}_{β} , \vec{y}_{β} and homogeneous coordinates \vec{p}'_{β} of the line passing through points represented by \vec{x}'_{β} , \vec{y}'_{β} are obtained by solving the linear systems

$$\vec{p}_{\beta}^{\top} \vec{x}_{\beta} = 0 \quad \text{and} \quad \vec{p}'_{\beta}{}^{\top} \vec{x}'_{\beta} = 0 \quad (9.29)$$

$$\vec{p}_{\beta}^{\top} \vec{y}_{\beta} = 0 \quad \vec{p}'_{\beta}{}^{\top} \vec{y}'_{\beta} = 0 \quad (9.30)$$

for a non-trivial solutions. Writing down the incidence of points and lines, we get

$$\lambda_1 \vec{p}_{\beta}^{\top} \mathbf{H}^{-1} \vec{x}'_{\beta} = 0 \Leftrightarrow \vec{p}_{\beta}^{\top} \mathbf{H}^{-1} \vec{x}'_{\beta} = 0$$

$$\lambda_2 \vec{p}_{\beta}^{\top} \mathbf{H}^{-1} \vec{y}'_{\beta} = 0 \Leftrightarrow \vec{p}_{\beta}^{\top} \mathbf{H}^{-1} \vec{y}'_{\beta} = 0$$

We see that \vec{p}'_{β} and $\mathbf{H}^{-\top} \vec{p}_{\beta}$ are solutions of the same set of homogeneous equations. When \vec{x}_{β} , \vec{y}_{β} are independent, then there is $\lambda \in \mathbb{R}$ such that

$$\lambda \vec{p}'_{\beta} = \mathbf{H}^{-\top} \vec{p}_{\beta} \quad (9.31)$$

since the solution space is one-dimensional. Equation 9.31 gives the relationship between homogeneous coordinates of a line and its image under homography \mathbf{H} .

9.3.1 Join under homography

Let us go one step further and establish formulas connecting line coordinates constructed by vector products. Construct joins as

$$\vec{p}_{\beta} = \vec{x}_{\beta} \times \vec{y}_{\beta} \quad \text{and} \quad \vec{p}'_{\beta} = \vec{x}'_{\beta} \times \vec{y}'_{\beta} \quad (9.32)$$

and use Equation 2.45 to get

$$\vec{x}_{\beta} \times \vec{y}_{\beta'} = \frac{\mathbf{H}^{-\top}}{|\mathbf{H}^{-\top}|} (\vec{x}_{\beta} \times \vec{y}_{\beta}) \quad (9.33)$$

$$(\lambda_1 \vec{x}'_{\beta'}) \times (\lambda_2 \vec{y}'_{\beta'}) = \frac{\mathbf{H}^{-\top}}{|\mathbf{H}^{-\top}|} (\vec{x}_{\beta} \times \vec{y}_{\beta}) \quad (9.34)$$

$$\vec{x}'_{\beta'} \times \vec{y}'_{\beta'} = \frac{\mathbf{H}^{-\top}}{\lambda_1 \lambda_2 |\mathbf{H}^{-\top}|} (\vec{x}_{\beta} \times \vec{y}_{\beta}) \quad (9.35)$$

$$\vec{p}'_{\beta'} = \frac{\mathbf{H}^{-\top}}{\lambda_1 \lambda_2 |\mathbf{H}^{-\top}|} \vec{p}_{\beta} \quad (9.36)$$

9.3.2 Meet under homography

Let us next look at the meet. Let point \vec{x} be the meet of lines \vec{p} and \vec{q} with line coordinates \vec{p}_{β} , \vec{q}_{β} , which are related by a homography \mathbf{H} to line coordinates \vec{p}'_{β} , and \vec{q}'_{β} , by

$$\lambda_1 \vec{p}'_{\beta} = \mathbf{H}^{-\top} \vec{p}_{\beta} \quad (9.37)$$

$$\lambda_2 \vec{q}'_{\beta} = \mathbf{H}^{-\top} \vec{q}_{\beta} \quad (9.38)$$

for some non-zero λ_1, λ_2 . Construct meets as

$$\vec{x}_\beta = \vec{p}_\beta \times \vec{q}_\beta \quad \text{and} \quad \vec{x}'_{\beta'} = \vec{p}'_{\beta'} \times \vec{q}'_{\beta'} \quad (9.39)$$

and, similarly as above, use Equation 2.45 to get

$$\vec{x}'_{\beta'} = \frac{(\mathbf{H}^{-\top})^{-\top}}{\lambda_1 \lambda_2 |(\mathbf{H}^{-\top})^{-\top}|} \vec{x}_\beta = \frac{\mathbf{H}}{\lambda_1 \lambda_2 |\mathbf{H}|} \vec{x}_\beta \quad (9.40)$$

9.3.3 Meet of join under homography

We can put the above together to get meet of join under homography. We consider two pairs of points represented by their homogeneous coordinates $\vec{x}_\beta, \vec{y}_\beta$, and $\vec{z}_\beta, \vec{w}_\beta$ and the corresponding pairs of points with their homogeneous coordinates $\vec{x}'_{\beta'}, \vec{y}'_{\beta'}$, and $\vec{z}'_{\beta'}, \vec{w}'_{\beta'}$, related by homography \mathbf{H} as

$$\lambda_1 \vec{x}'_{\beta'} = \mathbf{H} \vec{x}_\beta, \quad \lambda_2 \vec{y}'_{\beta'} = \mathbf{H} \vec{y}_\beta, \quad \lambda_3 \vec{z}'_{\beta'} = \mathbf{H} \vec{z}_\beta, \quad \lambda_4 \vec{w}'_{\beta'} = \mathbf{H} \vec{w}_\beta \quad (9.41)$$

Let us now consider point

$$\vec{v}'_{\beta'} = (\vec{x}'_{\beta'} \times \vec{y}'_{\beta'}) \times (\vec{z}'_{\beta'} \times \vec{w}'_{\beta'}) \quad (9.42)$$

$$= \left(\frac{\mathbf{H}^{-\top}}{\lambda_1 \lambda_2 |(\mathbf{H}^{-\top})^{-\top}|} (\vec{x}_\beta \times \vec{y}_\beta) \right) \times \left(\frac{\mathbf{H}^{-\top}}{\lambda_3 \lambda_4 |(\mathbf{H}^{-\top})^{-\top}|} (\vec{z}_\beta \times \vec{w}_\beta) \right) \quad (9.43)$$

$$= \frac{\mathbf{H} |\mathbf{H}|}{\lambda_1 \lambda_2 \lambda_3 \lambda_4} (\vec{x}_\beta \times \vec{y}_\beta) \times (\vec{z}_\beta \times \vec{w}_\beta) \quad (9.44)$$

$$= \frac{\mathbf{H} |\mathbf{H}|}{\lambda_1 \lambda_2 \lambda_3 \lambda_4} \vec{v}_\beta \quad (9.45)$$

9.3.4 Note on homographies that are rotations

First notice that homogeneous coordinates of points and lines constructed as combinations of joins and meets indeed behave under a homography as homogeneous coordinates constructed from affine coordinates of points.

Secondly, when the homography is a rotation and homogeneous coordinates are unit vectors, all λ 's become equal to one, the determinant of \mathbf{H} is one and $\mathbf{H}^{-\top} = \mathbf{H}$. Therefore, all homogeneous coordinates in the previous formulas become related just by \mathbf{H} .

9.4 Vanishing points

When modeling perspective projection in the affine space with affine projection planes, we meet somewhat unpleasant situations. For instance, imagine a projection of two parallel lines K, L , which are in a plane τ in the space into the projection plane π through the center C , Figure 9.10.

The lines K, L project to image lines k, l . As we go with two points X, Y along the lines k, l away from the projection plane, their images x, y get closer and closer to the point v in the image but they do not reach point v . We shall call this point of convergence of lines K, L the *vanishing point*⁷.

⁷Úběžník in Czech.

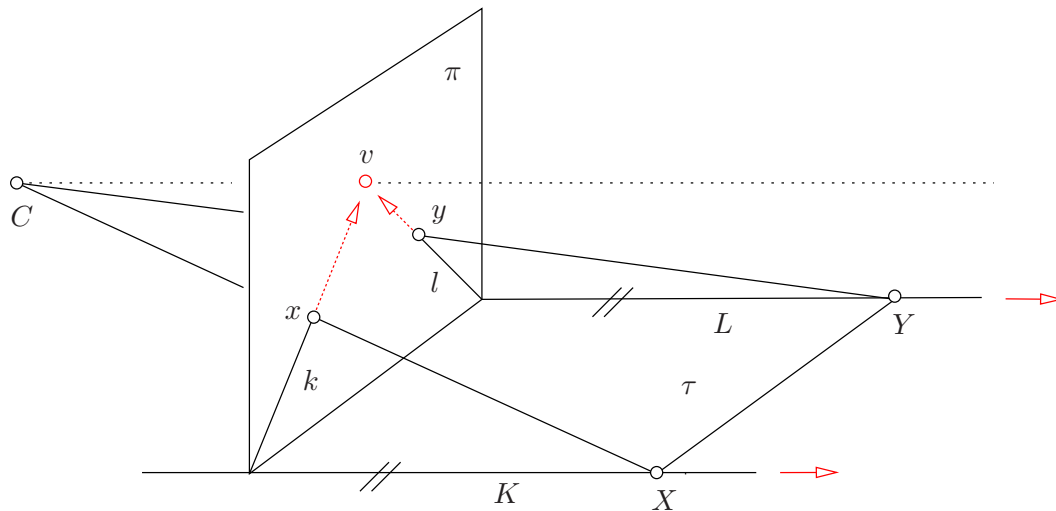

Figure 9.10: Vanishing point v is the point towards projections x and y tend as X and Y move away from π but which they never reach.

9.5 Vanishing line and horizon

If we take all sets of parallel lines in τ , each set with a different direction, then all the points of convergence in the image will fill a complete line h .

The line h is called the *vanishing line* or the *horizon*⁸ when τ is the ground plane.

Now, imagine that we project all points from τ to π using the affine geometrical projection model. Then, no point from τ will project to h . Similarly, when projecting in the opposite direction, i.e. π to τ , line h has no image, i.e. it does not project anywhere to τ .

When using the affine geometrical projection model with the real projective plane to model the perspective projection (which is equivalent to the algebraic model in \mathbb{R}^3), all points of the projective plane τ (obtained as the projective completion of the affine plane τ) will have exactly one image in the projective plane π (obtained as the projective completion of the affine plane π) and vice versa. This total symmetry is useful and beautiful.

⁸Horizont in Czech

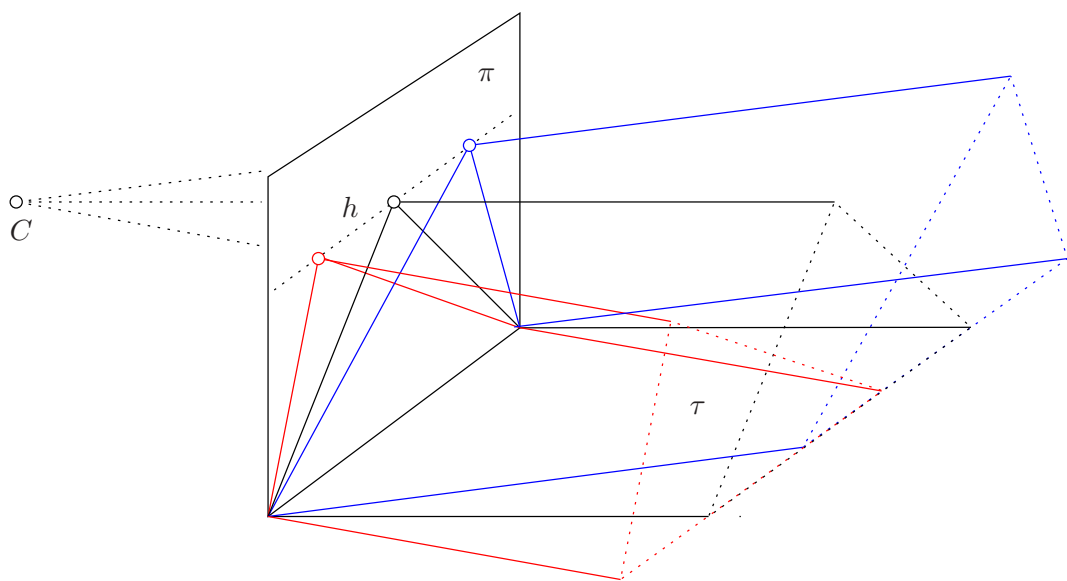

Figure 9.11: Vanishing line (horizon) h is the line of vanishing points.

10 Projective space

10.1 Motivation – the union of ideal points of all affine planes

Figure 10.1(a) shows a perspective image of three sets of parallel lines generated by sides of a cube in the three-dimensional real affine space. The images of the three sets of parallel lines converge to vanishing points V_1 , V_2 and V_3 . The cube has six faces. Each face generates two pairs of parallel lines and hence two vanishing points. Each face generates an affine plane which can be extended into a projective plane by adding the line of ideal points of that plane. The projection of the three ideal lines are vanishing lines $l_{12} = V_1 \vee V_2$, $l_{23} = V_2 \vee V_3$ and $l_{31} = V_3 \vee V_1$. Imagine now all possible affine planes of the three-dimensional affine space and their corresponding ideal points. Let us take the union V of the sets of ideal points of all such planes. There is exactly one ideal point for every set of parallel lines in V , i.e. there is a one-to-one correspondence between elements of V (ideal points) and directions in the three-dimensional affine space. Notice also that every plane π generates one ideal line l_∞ of its ideal points and that all other planes parallel with π generate the same l_∞ , Figure 10.1.

It suggests itself to extend the three-dimensional affine space by adding the set V to it, analogically to how we have extended the affine plane. In this new space, all parallel lines will intersect. We will call this space the *three-dimensional real projective space* and denote it \mathbb{P}^3 . Let us develop an algebraic model of \mathbb{P}^3 . It is practical to require this model to encompass the model of the real projective plane. The real projective plane is modeled algebraically by subspaces of \mathbb{R}^3 . Let us observe that subspaces of \mathbb{R}^4 will be a convenient algebraic model of \mathbb{P}^3 .

We start with the three-dimensional real affine space \mathbb{A}^3 and fix a coordinate system (O, δ) with $\delta = (\vec{d}_1, \vec{d}_2, \vec{d}_3)$. An affine plane π is a set of points of \mathbb{A}^3 represented in (O, δ) by the set of vectors

$$\pi = \{[x, y, z]^\top \mid ax + by + cz + d = 0, a, b, c, d \in \mathbb{R}, a^2 + b^2 + c^2 \neq 0\} \quad (10.1)$$

We see that the point of π represented by vector $[x, y, z]^\top$ can also be represented by one-dimensional subspace $\{\lambda [x, y, z, 1]^\top \mid \lambda \in \mathbb{R}\}$ of \mathbb{R}^4 and hence π can be seen as the set

$$\pi = \{\{\lambda [x, y, z, 1]^\top \mid \lambda \in \mathbb{R}\} \mid [a, b, c, d] [x, y, z, 1]^\top = 0, a, b, c, d \in \mathbb{R}, a^2 + b^2 + c^2 \neq 0\} \quad (10.2)$$

of one-dimensional subspaces of \mathbb{R}^4 .

Notice that we did not require $\lambda \neq 0$ in the above definition. This is because we establish the correspondence between a vector $[x, y, z]$ and the corresponding complete one-dimensional subspace $\{\lambda [x, y, z, 1]^\top, \lambda \in \mathbb{R}\}$ of \mathbb{R}^4 and since every linear space contains zero vector, we admit zero λ .

Every $[x, y, z]^\top \in \mathbb{R}^3$ represents in (O, δ) a point of \mathbb{A}^3 and hence the subset

$$\mathbb{A}^3 = \{\{\lambda [x, y, z, 1]^\top \mid \lambda \in \mathbb{R}\} \mid x, y, z \in \mathbb{R}\} \quad (10.3)$$

of one-dimensional subspaces of \mathbb{R}^4 represents \mathbb{A}^3 .

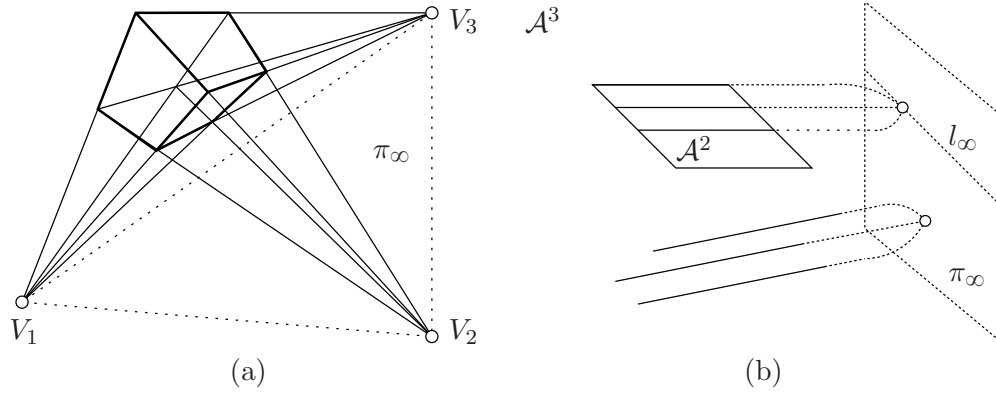

Figure 10.1: (a) A perspective image of a cube generates three vanishing points V_1 , V_2 and V_3 and hence also three vanishing lines l_{12} , l_{23} and l_{31} . (b) Every plane adds one line of ideal points to the three-dimensional affine space. Every ideal point corresponds to one direction, i.e. to a set of parallel lines. Each ideal line corresponds to a set of parallel planes.

We observe that we have not used all one-dimensional subspaces of \mathbb{R}^4 to represent \mathbb{A}^3 . The subset

$$\pi_\infty = \{ \{ \lambda [x, y, z, 0]^\top \mid \lambda \in \mathbb{R} \} \mid x, y, z \in \mathbb{R}, x^2 + y^2 + z^2 \neq 0 \} \quad (10.4)$$

of one-dimensional subspaces of \mathbb{R}^4 is in one-to-one correspondence with all non-zero vectors of \mathbb{R}^3 , i.e. in one-to-one correspondence with the set of directions in \mathbb{A}^3 . This is the set of ideal points which we add to \mathbb{A}^3 to get the three-dimensional real projective space

$$\mathbb{P}^3 = \{ \{ \lambda [x, y, z, w]^\top \mid \lambda \in \mathbb{R} \} \mid x, y, z, w \in \mathbb{R}, x^2 + y^2 + z^2 + w^2 \neq 0 \} \quad (10.5)$$

which is the set of all one-dimensional subspaces of \mathbb{R}^4 . Notice that $\mathbb{P}^3 = \mathbb{A}^3 \cup \pi_\infty$.

§ 1 Points Every non-zero vector of \mathbb{R}^4 generates a one-dimensional subspace and thus represents a point of \mathbb{P}^3 . The zero vector $[0, 0, 0, 0]^\top$ does not represent any point.

§ 2 Planes Affine planes $\pi_{\mathbb{A}^3}$, Equation 10.2, are in one-to-one correspondence to the subset

$$\pi_{\mathbb{A}^3} = \{ \{ \lambda [a, b, c, d]^\top \mid \lambda \in \mathbb{R} \} \mid a, b, c, d \in \mathbb{R}, a^2 + b^2 + c^2 \neq 0 \} \quad (10.6)$$

of the set of one-dimensional subspaces of \mathbb{R}^4 . There is only one one-dimensional subspace of \mathbb{R}^4 , $\{ \lambda [0, 0, 0, 1]^\top \mid \lambda \in \mathbb{R} \}$ missing in $\pi_{\mathbb{A}^3}$. It is exactly the one-dimensional subspace corresponding to the set π_∞ of ideal points of \mathbb{P}^3

$$\pi_\infty = \{ \{ \lambda [x, y, z, w]^\top \mid \lambda \in \mathbb{R} \} \mid x, y, z, w \in \mathbb{R}, x^2 + y^2 + z^2 \neq 0, [0, 0, 0, 1] [x, y, z, w]^\top = 0 \} \quad (10.7)$$

We can take another view upon planes and observe that affine planes are in one-to-one correspondence with the three-dimensional subspaces of \mathbb{R}^4 . The set π_∞ also corresponds to a three-dimensional subspace of \mathbb{R}^4 . Hence π_∞ can be considered another plane, *the ideal plane* of \mathbb{P}^3 .

The set of planes of \mathbb{P}^3 can be hence represented by the set of one-dimensional subspaces of \mathbb{R}^4

$$\pi_{\mathbb{P}^3} = \{ \{ \lambda [a, b, c, d]^T \mid \lambda \in \mathbb{R} \} \mid a, b, c, d \in \mathbb{R}, a^2 + b^2 + c^2 + d^2 \neq 0 \} \quad (10.8)$$

but can also be viewed as the set of three-dimensional subspaces of \mathbb{R}^4 .

We see that there is a duality between points and planes of \mathbb{P}^3 . They both are represented by one-dimensional subspaces of \mathbb{R}^4 and we see that point X represented by vector $\vec{X} = [x, y, z, w]^T$ is incident to plane π represented by vector $\vec{\pi} = [a, b, c, d]^T$, i.e. $X \circ \pi$, when

$$\vec{\pi}^T \vec{X} = [a \ b \ c \ d] \begin{bmatrix} x \\ y \\ z \\ w \end{bmatrix} = ax + by + cz + dw = 0 \quad (10.9)$$

§ 3 Lines Lines in \mathbb{P}^3 are represented by two-dimensional subspaces of \mathbb{R}^4 . Unlike in \mathbb{P}^2 , lines are not dual to points.

11 Camera auto-calibration

Camera auto-calibration is a process when the parameters of image formation are determined from properties of the observed scene or knowledge of camera motions. We will study camera auto-calibration methods and tasks related to metrology in images. We have seen in Chapter 7 that to measure the angle between projection rays we needed only matrix K . Actually, it is enough to know matrix¹

$$\omega = K^{-\top} K^{-1}$$

to measure the angle between the rays corresponding to image points $\vec{x}_{1\beta}$, $\vec{x}_{2\beta}$ as

$$\cos \angle(\vec{x}_1, \vec{x}_2) = \frac{\vec{x}_{1\beta}^\top K^{-\top} K^{-1} \vec{x}_{2\beta}}{\|K^{-1} \vec{x}_{1\beta}\| \|K^{-1} \vec{x}_{2\beta}\|} = \frac{\vec{x}_{1\beta}^\top \omega \vec{x}_{2\beta}}{\sqrt{\vec{x}_{1\beta}^\top \omega \vec{x}_{1\beta}} \sqrt{\vec{x}_{2\beta}^\top \omega \vec{x}_{2\beta}}} \quad (11.1)$$

Knowing ω is however (almost) equivalent to knowing K since K can be recovered from ω up to two signs as follows.

§ 1 Recovering K from ω Let us give a procedure for recovering K from ω . Assuming

$$K = \begin{bmatrix} k_{11} & k_{12} & k_{13} \\ 0 & k_{22} & k_{23} \\ 0 & 0 & 1 \end{bmatrix} \quad (11.2)$$

we get

$$K^{-1} = \begin{bmatrix} k_{11} & k_{12} & k_{13} \\ 0 & k_{22} & k_{23} \\ 0 & 0 & 1 \end{bmatrix}^{-1} = \begin{bmatrix} \frac{1}{k_{11}} & \frac{-k_{12}}{k_{11}k_{22}} & \frac{k_{12}k_{23}-k_{13}k_{22}}{k_{11}k_{22}} \\ 0 & \frac{1}{k_{22}} & \frac{-k_{23}}{k_{22}} \\ 0 & 0 & 1 \end{bmatrix} = \begin{bmatrix} m_{11} & m_{12} & m_{13} \\ 0 & m_{22} & m_{23} \\ 0 & 0 & 1 \end{bmatrix} \quad (11.3)$$

for some real $m_{11}, m_{12}, m_{13}, m_{22}$ and m_{23} . Equivalently, we get

$$K = \begin{bmatrix} \frac{1}{m_{11}} & \frac{-m_{12}}{m_{11}m_{22}} & \frac{m_{12}m_{23}-m_{13}m_{22}}{m_{11}m_{22}m_{23}} \\ 0 & \frac{1}{m_{22}} & \frac{-m_{23}}{m_{22}} \\ 0 & 0 & 1 \end{bmatrix} \quad (11.4)$$

Introducing the following notation

$$\omega = K^{-\top} K^{-1} = \begin{bmatrix} \omega_{11} & \omega_{12} & \omega_{13} \\ \omega_{12} & \omega_{22} & \omega_{23} \\ \omega_{13} & \omega_{23} & \omega_{33} \end{bmatrix} \quad (11.5)$$

¹In [15], ω is called the image of the absolute conic.

yields

$$\begin{bmatrix} \omega_{11} & \omega_{12} & \omega_{13} \\ \omega_{12} & \omega_{22} & \omega_{23} \\ \omega_{13} & \omega_{23} & \omega_{33} \end{bmatrix} = \begin{bmatrix} m_{11}^2 & m_{11} m_{12} & m_{11} m_{13} \\ m_{11} m_{12} & m_{12}^2 + m_{22}^2 & m_{12} m_{13} + m_{22} m_{23} \\ m_{11} m_{13} & m_{12} m_{13} + m_{22} m_{23} & m_{13}^2 + m_{23}^2 + 1 \end{bmatrix} \quad (11.6)$$

which can be solved for K^{-1} up to the sign of the rows of K^{-1} as follows. Equation 11.6 provides equations

$$\begin{aligned} \omega_{11} = m_{11}^2 &\Rightarrow m_{11} = s_1 \sqrt{\omega_{11}} \\ \omega_{12} = m_{11} m_{12} &\Rightarrow m_{12} = \omega_{12} / (s_1 \sqrt{\omega_{11}}) = s_1 \omega_{12} / \sqrt{\omega_{11}} \\ \omega_{13} = m_{11} m_{13} &\Rightarrow m_{13} = \omega_{13} / (s_1 \sqrt{\omega_{11}}) = s_1 \omega_{13} / \sqrt{\omega_{11}} \\ \omega_{22} = m_{12}^2 + m_{22}^2 &\Rightarrow m_{22} = s_2 \sqrt{\omega_{22} - m_{12}^2} = s_2 \sqrt{\omega_{22} - \omega_{12}^2 / \omega_{11}} \\ \omega_{23} = m_{12} m_{13} + m_{22} m_{23} &\Rightarrow m_{23} = s_2 (\omega_{23} - \omega_{12} \omega_{13} / \omega_{11}) / \sqrt{\omega_{22} - \omega_{12}^2 / \omega_{11}} \\ &= s_2 (\omega_{11} \omega_{23} - \omega_{12} \omega_{13}) / \sqrt{\omega_{11}^2 \omega_{22} - \omega_{11} \omega_{12}^2} \end{aligned}$$

which can be solved for m_{ij} with $s_1 = \pm 1$ and $s_2 = \pm 1$. Hence

$$K = \begin{bmatrix} s_1 \sqrt{\omega_{11}} & s_1 \omega_{12} / \sqrt{\omega_{11}} & s_1 \omega_{13} / \sqrt{\omega_{11}} \\ 0 & s_2 \sqrt{\omega_{22} - \omega_{12}^2 / \omega_{11}} & s_2 (\omega_{23} - \omega_{12} \omega_{13} / \omega_{11}) / \sqrt{\omega_{22} - \omega_{12}^2 / \omega_{11}} \\ 0 & 0 & 1 \end{bmatrix}^{-1} \quad (11.7)$$

Signs s_1, s_2 are determined by the choice of the image coordinate system. The standard choice is $s_1 = s_2 = 1$, which corresponds to $k_{11} > 0$ and $k_{22} > 0$.

Notice that $\sqrt{\omega_{11}}$ is never zero for a real camera since $m_{11} = \frac{1}{k_{11}} \neq 0$. There also holds true

$$\sqrt{\omega_{22} - \omega_{12}^2 / \omega_{11}} = \sqrt{m_{11}^2 - m_{12}^2} = \sqrt{\frac{1}{k_{11}^2} - \frac{k_{12}^2}{k_{11}^2 k_{22}^2}} = \frac{1}{k_{11} k_{22}} \sqrt{k_{22}^2 - k_{12}^2} \neq 0 \quad (11.8)$$

since $|k_{12}|$ is much smaller than $|k_{22}|$ for all real cameras.

11.1 Constraints on ω

Matrix ω is a 3×3 symmetric matrix and by this it has only six independent elements $\omega_{11}, \omega_{12}, \omega_{13}, \omega_{22}, \omega_{23}$ and ω_{33} . Let us next investigate additional constraints on ω , which follow from different choices of K .

§ 1 Constraints on ω for a general K Even a general K yields a constraint on ω . Equation 11.6 relates the six parameters of ω to only five parameters $m_{11}, m_{12}, m_{13}, m_{22}$ and m_{23} and hence the six parameters of ω can't be independent. Indeed, let us see that the following identity holds

true

$$\begin{aligned}
& (\omega_{23}^2 - \frac{\omega_{13}^2 \omega_{12}^2}{\omega_{11}^2} - (\omega_{22} - \frac{\omega_{12}^2}{\omega_{11}}) (\omega_{33} - \frac{\omega_{13}^2}{\omega_{11}} - 1))^2 - 4 \frac{\omega_{13}^2 \omega_{12}^2}{\omega_{11}^2} (\omega_{22} - \frac{\omega_{12}^2}{\omega_{11}}) (\omega_{33} - \frac{\omega_{13}^2}{\omega_{11}} - 1) \\
&= \left((m_{12}m_{13} + m_{22}m_{23})^2 - \frac{(m_{11}m_{13})^2(m_{11}m_{12})^2}{m_{11}^4} \right. \\
&\quad \left. - (m_{12}^2 + m_{22}^2 - \frac{(m_{11}m_{12})^2}{m_{11}^2})(m_{13}^2 + m_{23}^2 + 1 - \frac{(m_{11}m_{13})^2}{m_{11}^4} - 1) \right)^2 \\
&- 4 \frac{(m_{11}m_{13})^2(m_{11}m_{12})^2}{m_{11}^4} (m_{12}^2 + m_{22}^2 - \frac{(m_{11}m_{12})^2}{m_{11}^2})(m_{13}^2 + m_{23}^2 + 1 - \frac{(m_{11}m_{13})^2}{m_{11}^4} - 1) \\
&= ((m_{12}m_{13} + m_{22}m_{23})^2 - (m_{12}m_{13})^2 - (m_{22}m_{23})^2)^2 - 4(m_{12}m_{13})^2(m_{22}m_{23})^2 \\
&= (2(m_{12}m_{13})(m_{22}m_{23}))^2 - 4(m_{12}m_{13})^2(m_{22}m_{23})^2 \\
&= 0
\end{aligned} \tag{11.9}$$

Since $\omega_{11} \neq 0$, we get the following equivalent identity

$$\begin{aligned}
& (\omega_{11}^2 \omega_{23}^2 - \omega_{13}^2 \omega_{12}^2 - (\omega_{11} \omega_{22} - \omega_{12}^2) (\omega_{11} \omega_{33} - \omega_{13}^2 - \omega_{11}))^2 \\
&\quad - 4 \omega_{13}^2 \omega_{12}^2 (\omega_{11} \omega_{22} - \omega_{12}^2) (\omega_{11} \omega_{33} - \omega_{13}^2 - \omega_{11}) = 0
\end{aligned} \tag{11.10}$$

which is a polynomial equation of degree eight in elements of ω .

We shall see next that it makes sense to introduce a new matrix

$$\Omega = \begin{bmatrix} 1 & o_{12} & o_{13} \\ o_{12} & o_{22} & o_{23} \\ o_{13} & o_{23} & o_{33} \end{bmatrix} = \begin{bmatrix} 1 & \frac{\omega_{12}}{\omega_{11}} & \frac{\omega_{13}}{\omega_{11}} \\ \frac{\omega_{12}}{\omega_{11}} & \frac{\omega_{22}}{\omega_{11}} & \frac{\omega_{23}}{\omega_{11}} \\ \frac{\omega_{13}}{\omega_{11}} & \frac{\omega_{23}}{\omega_{11}} & \frac{\omega_{33}}{\omega_{11}} \end{bmatrix} \tag{11.11}$$

which contains only five unknowns, and use Equation 11.10 to get the positive ω_{11} from Ω by solving the following quadratic equation

$$a_2 \omega_{11}^2 + a_1 \omega_{11} + a_0 = 0 \tag{11.12}$$

with

$$\begin{aligned}
a_2 &= -4 o_{23}^2 o_{13}^2 o_{12}^2 + o_{23}^4 - 2 o_{23}^2 o_{22} o_{33} + 2 o_{13}^2 o_{12}^2 o_{22} o_{33} \\
&\quad - 2 o_{22}^2 o_{33} o_{13}^2 + o_{12}^4 o_{33}^2 + 2 o_{23}^2 o_{22} o_{13}^2 + 2 o_{23}^2 o_{12}^2 o_{33} \\
&\quad + o_{22}^2 o_{13}^4 + o_{22}^2 o_{33}^2 - 2 o_{22} o_{33}^2 o_{12}^2
\end{aligned} \tag{11.13}$$

$$\begin{aligned}
a_1 &= 2 o_{13}^2 o_{12}^2 o_{22} + 2 o_{23}^2 o_{22} - 2 o_{22}^2 o_{33} - 2 o_{12}^4 o_{33} \\
&\quad + 4 o_{22} o_{33} o_{12}^2 - 2 o_{23}^2 o_{12}^2 + 2 o_{22}^2 o_{13}^2
\end{aligned} \tag{11.14}$$

$$a_0 = -2 o_{22} o_{12}^2 + o_{22}^2 + o_{12}^4 \tag{11.15}$$

§ 2 Constraints on ω for K from square pixels Cameras have often square pixels, i.e. $\|\vec{b}_1\| = \|\vec{b}_2\| = 1$ and $\angle(\vec{b}_1, \vec{b}_2) = \pi/2$, which implies, Equations 7.13, 7.15, 7.16, a simplified

$$K = \begin{bmatrix} k_{11} & 0 & k_{13} \\ 0 & k_{11} & k_{23} \\ 0 & 0 & 1 \end{bmatrix} \tag{11.16}$$

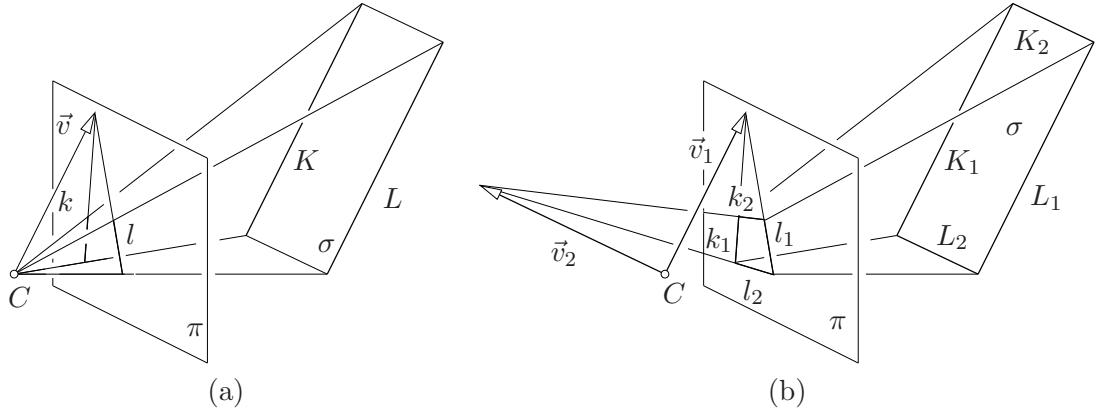

Figure 11.1: (a) Parallel lines K, L are projected to lines k, l with vanishing point represented by \vec{v} . Vector \vec{v} is parallel to k, l . (b) Vectors \vec{v}_1, \vec{v}_2 contain the same angle as pairs of lines K_1, K_2 or L_1, L_2 .

This gives also simpler

$$\omega = \frac{1}{k_{11}^2} \begin{bmatrix} 1 & 0 & -k_{13} \\ 0 & 1 & -k_{23} \\ -k_{13} & -k_{23} & k_{11}^2 + k_{13}^2 + k_{23}^2 \end{bmatrix} \quad (11.17)$$

We see that we get the following three identities

$$\omega_{12} = 0 \quad (11.18)$$

$$\omega_{22} - \omega_{11} = 0 \quad (11.19)$$

$$\omega_{13}^2 + \omega_{23}^2 - \omega_{11}\omega_{33} + \omega_{11} = 0 \quad (11.20)$$

We also get simpler

$$\Omega = \begin{bmatrix} 1 & 0 & o_{13} \\ 0 & 1 & o_{23} \\ o_{13} & o_{23} & o_{33} \end{bmatrix} = k_{11}^2 \omega = \begin{bmatrix} 1 & 0 & -k_{13} \\ 0 & 1 & -k_{23} \\ -k_{13} & -k_{23} & k_{11}^2 + k_{13}^2 + k_{23}^2 \end{bmatrix} \quad (11.21)$$

and use Equation 11.21 to get

$$k_{11}^2 = o_{33} - o_{13}^2 - o_{23}^2 \quad (11.22)$$

$$k_{13} = -o_{13} \quad (11.23)$$

$$k_{23} = -o_{23} \quad (11.24)$$

11.2 Camera calibration from angles between projection rays

We will now show how to calibrate a camera by finding the matrix $\omega = K^{-T}K^{-1}$.

In general, matrix ω is constrained by knowing angles contained between pairs of projection rays. Consider two projection rays with direction vectors \vec{x}_1, \vec{x}_2 . Then the angle between them

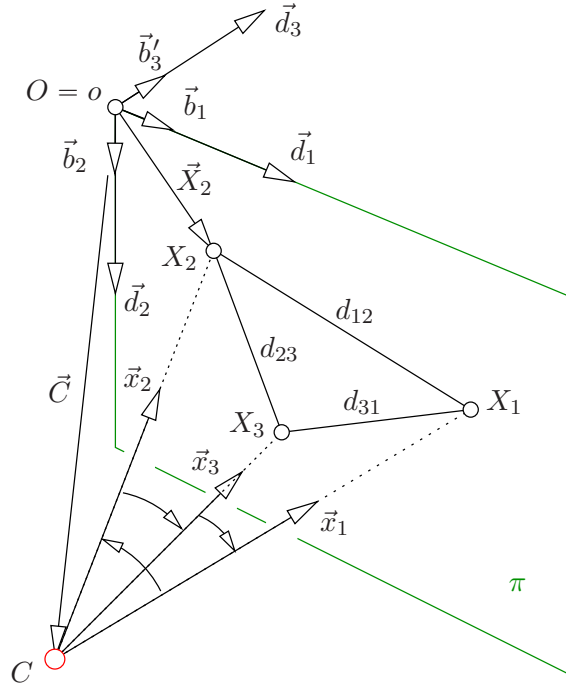

Figure 11.2: Images of three points with known angles between their rays can be used to calibrate cameras with square pixels. The position of image center $\vec{C}_{\delta'}$ can be computed in the orthogonal coordinate system (o, δ') using the absolute pose problem from Chapter 7.3. Matrix K is composed from coordinates of $\vec{C}_{\delta'}$.

is related to ω and Ω by

$$\cos \angle(\vec{x}_1, \vec{x}_2) = \frac{\vec{x}_{1\beta}^\top \omega \vec{x}_{2\beta}}{\sqrt{\vec{x}_{1\beta}^\top \omega \vec{x}_{1\beta}} \sqrt{\vec{x}_{2\beta}^\top \omega \vec{x}_{2\beta}}} = \frac{\vec{x}_{1\beta}^\top \Omega \vec{x}_{2\beta}}{\sqrt{\vec{x}_{1\beta}^\top \Omega \vec{x}_{1\beta}} \sqrt{\vec{x}_{2\beta}^\top \Omega \vec{x}_{2\beta}}} \quad (11.25)$$

Squaring the above and clearing the denominators gives

$$(\cos \angle(\vec{x}_1, \vec{x}_2))^2 (\vec{x}_{1\beta}^\top \Omega \vec{x}_{1\beta}) (\vec{x}_{2\beta}^\top \Omega \vec{x}_{2\beta}) = (\vec{x}_{1\beta}^\top \Omega \vec{x}_{2\beta})^2 \quad (11.26)$$

which is a second order equation in elements of Ω . To find Ω , which has five independent parameters for a general K , we need to be able to establish five pairs of rays with known angles and solve a system of five quadratic equations 11.26 above.

§ 1 Camera with square pixels A simpler situation arises when the camera has square pixels. Then, we can use constraints from § 2 to recover ω and K from three pairs of rays containing known angles. That amounts to solving three second order equations 11.26 in o_{13}, o_{23}, o_{33} .

However, this is actually exactly the same problem as we have already solved in Section 7.3. Figure 11.2 shows an image plane π with a coordinate system (o, δ') with $\delta' = (\vec{b}_1, \vec{b}_2, \vec{b}_3)$ derived from the image coordinate system (o, α) . Having square pixels, vectors \vec{b}_1, \vec{b}_2 can be

complemented with \vec{b}'_3 to form an orthogonal coordinates system ($O = o, \delta'$). Next, we choose the global orthonormal coordinate system, ($O = o, \delta$), $\delta = (\vec{d}_1, \vec{d}_2, \vec{d}_3)$, such that

$$\vec{d}_1 = \frac{\vec{b}_1}{\|\vec{b}_1\|}, \quad \vec{d}_2 = \frac{\vec{b}_2}{\|\vec{b}_1\|}, \quad \text{and} \quad \vec{d}_3 = \frac{\vec{b}'_3}{\|\vec{b}_1\|} \quad (11.27)$$

and hence

$$\vec{x}_\delta = \begin{bmatrix} \|\vec{b}_1\| & 0 & 0 \\ 0 & \|\vec{b}_1\| & 0 \\ 0 & 0 & \|\vec{b}_1\| \end{bmatrix} \vec{x}_{\delta'} \quad (11.28)$$

We know angles $\angle(\vec{x}_1, \vec{x}_2)$, $\angle(\vec{x}_2, \vec{x}_3)$ and $\angle(\vec{x}_3, \vec{x}_1)$. We also know image points $\vec{u}_{1\alpha} = \vec{X}_{1\delta'}$, $\vec{u}_{2\alpha} = \vec{X}_{2\delta'}$, $\vec{u}_{3\alpha} = \vec{X}_{3\delta'}$ and thus we can compute distances $d_{12} = \|\vec{X}_{2\delta'} - \vec{X}_{1\delta'}\|$, $d_{23} = \|\vec{X}_{3\delta'} - \vec{X}_{2\delta'}\|$ and $d_{31} = \|\vec{X}_{3\delta'} - \vec{X}_{1\delta'}\|$. Having that, we can find the pose $\vec{C}_{\delta'} = [c_1, c_2, c_3]^\top$ of the camera center C in (O, δ') by solving the absolute pose problem from Chapter 7.3. We will select a solution with $c_3 < 0$ and, if necessary, use a fourth point in π to choose the right solution among them. To find K , we can form the following equation

$$\begin{bmatrix} 0 \\ 0 \\ 1 \end{bmatrix} = \frac{1}{f} [KR - KR\vec{C}_{\delta'}] \begin{bmatrix} 0 \\ 0 \\ 0 \\ 1 \end{bmatrix} \quad (11.29)$$

since point o is represented by $[0, 0, 1]^\top$ in β and by $[0, 0, 0]^\top$ in δ . Coordinate system (O, δ) is chosen such that $R = I$ and $\vec{C}_\delta = \|\vec{b}_1\| \vec{C}_{\delta'}$, and thus we get

$$K^{-1} \begin{bmatrix} 0 \\ 0 \\ 1 \end{bmatrix} = -\frac{\|\vec{b}_1\|}{f} \vec{C}_{\delta'} \quad (11.30)$$

Now, let us consider matrix K as in Equation 11.16 and use the interpretation of elements of K from Chapter 7, Equations 7.16, 7.17. We can write

$$K = \begin{bmatrix} \frac{f}{\|\vec{b}_1\|} & 0 & k_{13} \\ 0 & \frac{f}{\|\vec{b}_1\|} & k_{23} \\ 0 & 0 & 1 \end{bmatrix} \quad \text{an thus} \quad K^{-1} = \begin{bmatrix} \frac{\|\vec{b}_1\|}{f} & 0 & -\frac{\|\vec{b}_1\|}{f} k_{13} \\ 0 & \frac{\|\vec{b}_1\|}{f} & -\frac{\|\vec{b}_1\|}{f} k_{23} \\ 0 & 0 & 1 \end{bmatrix} \quad (11.31)$$

and use it in Equation 11.30 to get

$$\begin{bmatrix} k_{13} \\ k_{23} \\ -\frac{f}{\|\vec{b}_1\|} \end{bmatrix} = \begin{bmatrix} c_1 \\ c_2 \\ c_3 \end{bmatrix} \quad (11.32)$$

and thus

$$K = \begin{bmatrix} -c_3 & 0 & c_1 \\ 0 & -c_3 & c_2 \\ 0 & 0 & 1 \end{bmatrix} \quad (11.33)$$

11.3 Camera calibration from vanishing points

Let us first make an interesting observation about parallel lines in space and its corresponding vanishing point in an image. Let us consider a pair of parallel lines K, L in space as shown in Figure 11.1(a). There is an affine plane σ containing the lines. The lines K, L are projected to image plane π into lines k, l , respectively.

Now, first extend affine plane σ to a projective plane Σ using the camera center C . Then, define a coordinate system (C, δ) with orthonormal basis $\delta = (\vec{d}_1, \vec{d}_2, \vec{d}_3)$ such that vectors \vec{d}_1, \vec{d}_2 span affine plane σ .

Let $\vec{K}_{\bar{\delta}}, \vec{L}_{\bar{\delta}}$ be homogeneous coordinates of lines K, L w.r.t. $\bar{\delta}$. Then

$$\vec{w}_{\delta} = \vec{K}_{\bar{\delta}} \times \vec{L}_{\bar{\delta}} \quad (11.34)$$

are homogeneous coordinates of the intersection of lines K, L in Σ .

Next, extend the affine plane π to a projective plane Π using the camera center C with the (camera) coordinate system (C, β) .

Let $\vec{k}_{\bar{\beta}}, \vec{l}_{\bar{\beta}}$ be homogeneous coordinates of lines k, l w.r.t. $\bar{\beta}$. Then

$$\vec{v}_{\beta} = \vec{k}_{\bar{\beta}} \times \vec{l}_{\bar{\beta}} \quad (11.35)$$

are homogeneous coordinates of the intersection of lines k, l in Π .

Now, consider Equation 8.14 for planes Σ and Π . Since δ is orthonormal, we have $K' = \mathbf{I}$ and thus that there is a homography

$$\mathbf{H} = \mathbf{K}\mathbf{R} \quad (11.36)$$

which maps plane Σ to plane Π . Matrices \mathbf{K} and \mathbf{R} of the camera are here w.r.t. the world coordinate system (C, δ) .

We see that there is a real λ such that there holds

$$\lambda \vec{v}_{\beta} = \mathbf{K}\mathbf{R} \vec{w}_{\delta} \quad (11.37)$$

true.

§ 1 Pairs of “orthogonal” vanishing points and camera with square pixels Let us have two pairs of parallel lines in space, Figure 11.1(b), such that they are also orthogonal, i.e. let K_1 be parallel with L_1 and K_2 be parallel with L_2 and at the same time let K_1 be orthogonal to K_2 and L_1 be orthogonal to L_2 . This, for instance, happens when lines K_1, L_1, K_2, L_2 form a rectangle but they also may be arranged in the three-dimensional space as non-intersecting.

Let lines k_1, l_1, k_2, l_2 be the projections of K_1, L_1, K_2, L_2 , respectively, represented by the corresponding vectors $\vec{k}_{1\bar{\beta}}, \vec{l}_{1\bar{\beta}}, \vec{k}_{2\bar{\beta}}, \vec{l}_{2\bar{\beta}}$ in the camera coordinates system with (in general non-orthogonal) basis β . Lines k_1 and l_1 , resp. k_2 and l_2 , generate vanishing points

$$\begin{aligned} \vec{v}_{1\beta} &= \vec{k}_{1\bar{\beta}} \times \vec{l}_{1\bar{\beta}} \\ \vec{v}_{2\beta} &= \vec{k}_{2\bar{\beta}} \times \vec{l}_{2\bar{\beta}} \end{aligned}$$

The perpendicularity of \vec{w}_1 to \vec{w}_2 is, in the camera orthogonal basis δ , modeled by

$$\vec{w}_{1\delta}^{\top} \vec{w}_{2\delta} = 0 \quad (11.38)$$

We therefore get from Equation 11.37

$$\vec{v}_{1\beta}^\top \mathbf{K}^{-\top} \mathbf{R}^{-\top} \mathbf{R}^{-1} \mathbf{K}^{-1} \vec{v}_{2\beta} = 0 \quad (11.39)$$

$$\vec{v}_{1\beta}^\top \mathbf{K}^{-\top} \mathbf{K}^{-1} \vec{v}_{2\beta} = 0 \quad (11.40)$$

$$\vec{v}_{1\beta}^\top \omega \vec{v}_{2\beta} = 0 \quad (11.41)$$

which is a linear homogeneous equation in ω . Assuming further square pixels, we get, § 2,

$$\vec{v}_{1\beta}^\top \omega \vec{v}_{2\beta} = 0$$

$$\vec{v}_{1\beta}^\top \Omega \vec{v}_{2\beta} = 0$$

$$\begin{bmatrix} v_{11} & v_{12} & v_{13} \end{bmatrix} \begin{bmatrix} 1 & 0 & o_{13} \\ 0 & 1 & o_{23} \\ o_{13} & o_{23} & o_{33} \end{bmatrix} \begin{bmatrix} v_{21} \\ v_{22} \\ v_{23} \end{bmatrix} = 0$$

$$\begin{bmatrix} v_{23} v_{11} + v_{21} v_{13} & v_{23} v_{12} + v_{22} v_{13} & v_{23} v_{13} \end{bmatrix} \begin{bmatrix} o_{13} \\ o_{23} \\ o_{33} \end{bmatrix} = -(v_{21} v_{11} + v_{22} v_{12})$$

Now, we need only 3 pairs of perpendicular vanishing points, e.g. to observe 3 rectangles not all in one plane to compute o_{13}, o_{23}, o_{33} and then

$$k_{13} = -o_{13}$$

$$k_{23} = -o_{23}$$

$$k_{11} = \sqrt{o_{33} - k_{13}^2 - k_{23}^2}$$

11.4 Camera calibration from images of squares

Let us exploit the relationship between the coordinates of points X , which all lie in a plane σ and are measured in a coordinate system $(O, \vec{d}_1, \vec{d}_2)$ in σ , Figure 8.2. The points X are projected by a perspective camera with the camera coordinate system is $(C, \beta), \beta = (\vec{b}_1, \vec{b}_2, \vec{b}_3)$ and projection matrix \mathbf{P} into image coordinates $[u \ v]^\top$, w.r.t. an image coordinate system $(o, \vec{b}_1, \vec{b}_2)$, Equation 8.30. See paragraph § 1 to recall that the columns of \mathbf{P} can be written as

$$\mathbf{P} = \left[\mathbf{K} \mathbf{R} \mid -\mathbf{K} \mathbf{R} \vec{C}_\delta \right] = \left[\vec{d}_{1\nu} \quad \vec{d}_{2\nu} \quad \vec{d}_{3\nu} \quad -\vec{C}_\nu \right] \quad (11.42)$$

and therefore we get the columns

$$\mathbf{h}_1 = \mathbf{p}_1 = \vec{d}_{1\nu} \quad (11.43)$$

$$\mathbf{h}_2 = \mathbf{p}_2 = \vec{d}_{2\nu} \quad (11.44)$$

$$\mathbf{h}_3 = \mathbf{p}_4 = -\vec{C}_\nu \quad (11.45)$$

of the homography \mathbf{H} mapping σ to π as defined in Equation 8.31.

Now imagine that we are observing a square with 4 corner points X_1, X_2, X_3 and X_4 in the plane σ and we construct the coordinate system in σ by assigning coordinates to the corners as

$$\vec{X}_{1\delta} = [0 \ 0 \ 0] \quad (11.46)$$

$$\vec{d}_{1\delta} = \vec{X}_{2\delta} = [1 \ 0 \ 0] \quad (11.47)$$

$$\vec{d}_{2\delta} = \vec{X}_{3\delta} = [0 \ 1 \ 0] \quad (11.48)$$

$$\vec{X}_{4\delta} = [1 \ 1 \ 0] \quad (11.49)$$

We see that we get two constraints on $\vec{d}_{1\delta}, \vec{d}_{2\delta}$

$$\vec{d}_{1\delta}^\top \vec{d}_{2\delta} = 0 \quad (11.50)$$

$$\vec{d}_{1\delta}^\top \vec{d}_{1\delta} - \vec{d}_{2\delta}^\top \vec{d}_{2\delta} = 0 \quad (11.51)$$

which lead to

$$\vec{d}_{1\nu}^\top \mathbf{K}^{-\top} \mathbf{K}^{-1} \vec{d}_{2\nu} = 0 \quad (11.52)$$

$$\vec{d}_{1\beta}^\top \mathbf{K}^{-\top} \mathbf{K}^{-1} \vec{d}_{1\beta} - \vec{d}_{2\nu}^\top \mathbf{K}^{-\top} \mathbf{K}^{-1} \vec{d}_{2\nu} = 0 \quad (11.53)$$

by using $\vec{d}_{i\nu} = \mathbf{K} \mathbf{R} \vec{d}_{i\delta}$ for $i = 1, 2$, and $\mathbf{R}^\top \mathbf{R} = \mathbf{I}$.

These are two linear equations on ω and hence also, see § 1, on Ω

$$\vec{d}_{1\nu}^\top \Omega \vec{d}_{2\nu} = 0 \quad (11.54)$$

$$\vec{d}_{1\nu}^\top \Omega \vec{d}_{1\nu} - \vec{d}_{2\nu}^\top \Omega \vec{d}_{2\nu} = 0 \quad (11.55)$$

on ω in terms of estimated $\lambda \mathbf{H}$

$$\mathbf{h}_1^\top \Omega \mathbf{h}_2 = 0 \quad (11.56)$$

$$\mathbf{h}_1^\top \Omega \mathbf{h}_1 - \mathbf{h}_2^\top \Omega \mathbf{h}_2 = 0 \quad (11.57)$$

One square provides two equations and therefore three squares in two planes in a general position suffice to calibrate full \mathbf{K} . Actually, such three squares provide one more equations than necessary since Ω has only five parameters. Hence, it is enough observe two squares and one rectangle to get five constraints. Similarly, one square and one rectangle in a plane then suffice to calibrate \mathbf{K} when pixels are square.

Notice also that we have never used the special choice of coordinates of \vec{X}_δ . Indeed, point X_4 could be anywhere provided that we know how to assign it coordinates in $(O, \vec{d}_1, \vec{d}_2)$.

To calibrate the camera, we first assign coordinates to the corners of the square as above, then find the homography \mathbf{H} from the plane to the image

$$\lambda_i \vec{x}_{i\beta} = \mathbf{H} \vec{X}_{i\delta} \quad (11.58)$$

for $\alpha_i = 1, \dots, 4$ and finally use columns of \mathbf{H} the find Ω .

12 Two-view scene reconstruction

Imagine two cameras giving two images of the space from two different view points. We will next investigate how to (re-)construct camera projection matrices and meaningful coordinates of points in the space such that the reconstructed cameras and the reconstructed points generate the images.

12.1 Epipolar geometry

Figure 12.1 shows two cameras with different centers C_1, C_2 and image planes π_1, π_2 , observing a general point X as u_1, u_2 . Baseline b connecting image centers C_1, C_2 intersects π_1, π_2 in *epipoles* e_1, e_2 . Points C_1, C_2 and X form *epipolar plane* σ , which intersects π_1 in *epipolar line* l_1 and π_2 in epipolar line l_2 . Epipolar line l_1 passes through epipole e_1 and through image point u_1 . Epipolar line l_2 passes through epipole e_2 and through image point u_2 .

Let us next find the relationship between image points, epipoles, epipolar lines as a function of camera parameters, Figure 12.2.

Assume a world coordinate system (O, δ) and cameras C_1, C_2 with camera projection matrices

$$P_1 = \left[K_1 R_1 \mid -K_1 R_1 \vec{C}_{1\delta} \right] \quad \text{and} \quad P_2 = \left[K_2 R_2 \mid -K_2 R_2 \vec{C}_{2\delta} \right] \quad (12.1)$$

Point X is projected to image planes π_1, π_2 , with respective coordinate systems $(o_1, \beta_1), (o_2, \beta_2)$, as

$$\zeta_1 \vec{x}_{1\beta_1} = P_1 \begin{bmatrix} \vec{X}_\delta \\ 1 \end{bmatrix} \quad \text{and} \quad \zeta_2 \vec{x}_{2\beta_2} = P_2 \begin{bmatrix} \vec{X}_\delta \\ 1 \end{bmatrix} \quad (12.2)$$

for some $\zeta_1 > 0$ and $\zeta_2 > 0$, which then leads to

$$\zeta_1 \vec{x}_{1\beta_1} = K_1 R_1 (\vec{X}_\delta - \vec{C}_{1\delta}) \quad \text{and} \quad \zeta_2 \vec{x}_{2\beta_2} = K_2 R_2 (\vec{X}_\delta - \vec{C}_{2\delta}) \quad (12.3)$$

$$\zeta_1 R_1^\top K_1^{-1} \vec{x}_{1\beta_1} = \vec{X}_\delta - \vec{C}_{1\delta} \quad \zeta_2 R_2^\top K_2^{-1} \vec{x}_{2\beta_2} = \vec{X}_\delta - \vec{C}_{2\delta} \quad (12.4)$$

Consider now that vectors $\vec{X}_\delta - \vec{C}_{1\delta}, \vec{X}_\delta - \vec{C}_{2\delta}$ and $\vec{C}_{2\delta} - \vec{C}_{1\delta}$ form a triangle and hence

$$\vec{C}_{2\delta} - \vec{C}_{1\delta} = (\vec{X}_\delta - \vec{C}_{1\delta}) - (\vec{X}_\delta - \vec{C}_{2\delta}) \quad (12.5)$$

$$\vec{C}_{2\delta} - \vec{C}_{1\delta} = \zeta_1 R_1^\top K_1^{-1} \vec{x}_{1\beta_1} - \zeta_2 R_2^\top K_2^{-1} \vec{x}_{2\beta_2} \quad (12.6)$$

with $\zeta_1 > 0$ and $\zeta_2 > 0$ for the standard choice of camera coordinate systems.

We shall next eliminate depths ζ_1, ζ_2 by exploiting the vector product identities, see Paragraph 2.3,

$$\vec{0} = \vec{x} \times \vec{x} = [\vec{x}]_\times \vec{x} \quad (12.7)$$

$$\vec{0} = \vec{y}^\top (\vec{x} \times \vec{y}) = \vec{y}^\top [\vec{x}]_\times \vec{y} \quad (12.8)$$

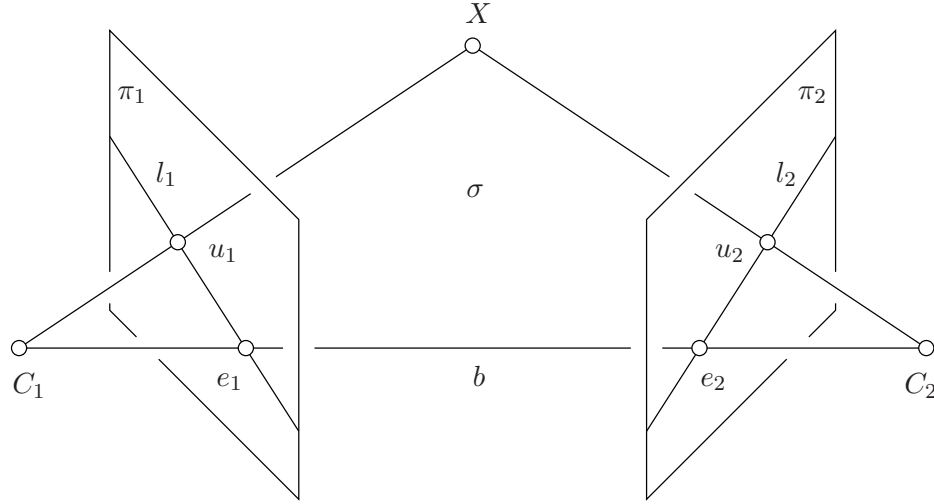

Figure 12.1: Epipolar geometry of two cameras.

for all $\vec{x}, \vec{y} \in \mathbb{R}^3$.

We first vector-multiply Equation 12.6 by $\vec{C}_{2\delta} - \vec{C}_{1\delta}$ from the left to get

$$0 = \left[\vec{C}_{2\delta} - \vec{C}_{1\delta} \right]_{\times} \zeta_1 \mathbf{R}_1^{\top} \mathbf{K}_1^{-1} \vec{x}_{1\beta_1} - \left[\vec{C}_{2\delta} - \vec{C}_{1\delta} \right]_{\times} \zeta_2 \mathbf{R}_2^{\top} \mathbf{K}_2^{-1} \vec{x}_{2\beta_2} \quad (12.9)$$

and then multiply Equation 12.9 by $\zeta_2 \vec{x}_{2\beta_2}^{\top} \mathbf{K}_2^{-\top} \mathbf{R}_2$ from the left to get

$$0 = \zeta_2 \vec{x}_{2\beta_2}^{\top} \mathbf{K}_2^{-\top} \mathbf{R}_2 \left[\vec{C}_{2\delta} - \vec{C}_{1\delta} \right]_{\times} \zeta_1 \mathbf{R}_1^{\top} \mathbf{K}_1^{-1} \vec{x}_{1\beta_1} \quad (12.10)$$

which, since $\zeta_1 \neq 0$ and $\zeta_2 \neq 0$, is equivalent with

$$0 = \vec{x}_{2\beta_2}^{\top} \mathbf{K}_2^{-\top} \mathbf{R}_2 \left[\vec{C}_{2\delta} - \vec{C}_{1\delta} \right]_{\times} \mathbf{R}_1^{\top} \mathbf{K}_1^{-1} \vec{x}_{1\beta_1} \quad (12.11)$$

$$0 = \vec{x}_{2\beta_2}^{\top} \mathbf{K}_2^{-\top} \mathbf{E} \mathbf{K}_1^{-1} \vec{x}_{1\beta_1} \quad (12.12)$$

$$0 = \vec{x}_{2\beta_2}^{\top} \mathbf{F} \vec{x}_{1\beta_1} \quad (12.13)$$

where we introduced the *essential matrix* $\mathbf{E} \in \mathbb{R}^{3 \times 3}$ as

$$\mathbf{E} = \mathbf{R}_2 \left[\vec{C}_{2\delta} - \vec{C}_{1\delta} \right]_{\times} \mathbf{R}_1^{\top} \quad (12.14)$$

and the *fundamental matrix* $\mathbf{F} \in \mathbb{R}^{3 \times 3}$ as

$$\mathbf{F} = \mathbf{K}_2^{-\top} \mathbf{R}_2 \left[\vec{C}_{2\delta} - \vec{C}_{1\delta} \right]_{\times} \mathbf{R}_1^{\top} \mathbf{K}_1^{-1} \quad (12.15)$$

Let us next introduce epipoles to pass from vectors in δ to vectors in β_1, β_2 , which are measurable in images.

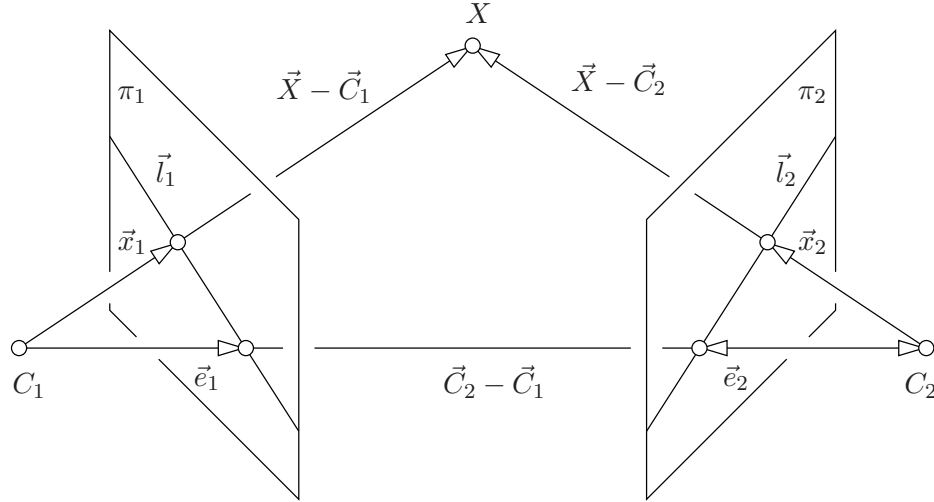

Figure 12.2: Vectors of the epipolar geometry.

The projection e_1 of the the camera center \vec{C}_2 to the first image as well as the projection e_2 of the the camera center \vec{C}_1 to the second image are obtained as

$$\zeta_1 \vec{e}_{1\beta_1} = \mathbf{P}_1 \begin{bmatrix} \vec{C}_{2\delta} \\ 1 \end{bmatrix} = \mathbf{K}_1 \mathbf{R}_1 (\vec{C}_{2\delta} - \vec{C}_{1\delta}) \quad (12.16)$$

$$\zeta_2 \vec{e}_{2\beta_2} = \mathbf{P}_2 \begin{bmatrix} \vec{C}_{1\delta} \\ 1 \end{bmatrix} = \mathbf{K}_2 \mathbf{R}_2 (\vec{C}_{1\delta} - \vec{C}_{2\delta}) \quad (12.17)$$

for some $\zeta_1 > 0$ and $\zeta_2 > 0$.

We can now substitute Equation 12.16 into Equation 12.15 to get

$$\mathbf{F} = \mathbf{K}_2^{-\top} \mathbf{R}_2 \begin{bmatrix} \vec{C}_{2\delta} - \vec{C}_{1\delta} \\ \times \end{bmatrix} \mathbf{R}_1^\top \mathbf{K}_1^{-1} \quad (12.18)$$

$$= \mathbf{K}_2^{-\top} \mathbf{R}_2 \left[\zeta_1 \mathbf{R}_1^\top \mathbf{K}_1^{-1} \vec{e}_{1\beta_1} \right]_\times \mathbf{R}_1^\top \mathbf{K}_1^{-1} \quad (12.19)$$

$$= \zeta_1 \mathbf{K}_2^{-\top} \mathbf{R}_2 \frac{(\mathbf{R}_1^\top \mathbf{K}_1^{-1})^{-\top}}{|(\mathbf{R}_1^\top \mathbf{K}_1^{-1})^{-\top}|} [\vec{e}_{1\beta_1}]_\times \quad (12.20)$$

$$= \frac{\zeta_1}{|\mathbf{K}_1|} \mathbf{K}_2^{-\top} \mathbf{R}_2 \mathbf{R}_1^\top \mathbf{K}_1^\top [\vec{e}_{1\beta_1}]_\times \quad (12.21)$$

We used the result from § 2, which shows how the vector product behaves under the change of a basis.

Analogically, we substitute Equation 12.17 into Equation 12.15 to get

$$\mathbf{F} = \mathbf{K}_2^{-\top} \mathbf{R}_2 \left[\vec{C}_{2\delta} - \vec{C}_{1\delta} \right]_{\times} \mathbf{R}_1^{\top} \mathbf{K}_1^{-1} \quad (12.22)$$

$$= \mathbf{K}_2^{-\top} \mathbf{R}_2 \left[-\zeta_2 \mathbf{R}_2^{\top} \mathbf{K}_2^{-1} \vec{e}_{2\beta_2} \right]_{\times} \mathbf{R}_1^{\top} \mathbf{K}_1^{-1} \quad (12.23)$$

$$= \left(\left[\zeta_2 \mathbf{R}_2^{\top} \mathbf{K}_2^{-1} \vec{e}_{2\beta_2} \right]_{\times} \mathbf{R}_2^{\top} \mathbf{K}_2^{-1} \right)^{\top} \mathbf{R}_1^{\top} \mathbf{K}_1^{-1} \quad (12.24)$$

$$= \left(\frac{\zeta_2}{|\mathbf{K}_2|} \mathbf{R}_2^{\top} \mathbf{K}_2^{\top} \left[\vec{e}_{2\beta_2} \right]_{\times} \right)^{\top} \mathbf{R}_1^{\top} \mathbf{K}_1^{-1} \quad (12.25)$$

$$= -\frac{\zeta_2}{|\mathbf{K}_2|} \left[\vec{e}_{2\beta_2} \right]_{\times} \mathbf{K}_2 \mathbf{R}_2 \mathbf{R}_1^{\top} \mathbf{K}_1^{-1} \quad (12.26)$$

We used additional properties of the linear representation of the vector product from § 3.

We see from Equations 12.21 and 12.26 that it is possible to recover homogeneous coordinates of the epipoles from \mathbf{F} by solving equations

$$\mathbf{F} \vec{e}_{1\beta_1} = 0 \quad \text{and} \quad \mathbf{F}^{\top} \vec{e}_{2\beta_2} = 0 \quad (12.27)$$

for a non-zero multiples of $\vec{e}_{1\beta_1}$, $\vec{e}_{2\beta_2}$. We also see that matrix \mathbf{F} has rank smaller than three since it has a non-zero null space $\vec{e}_{1\beta_1}$. Since, rank of $\left[\vec{C}_{2\delta} - \vec{C}_{1\delta} \right]_{\times}$ is two for non-zero $\vec{C}_{2\delta} - \vec{C}_{1\delta}$, \mathbf{F} has rank two when camera centers do not coincide.

Let us look at the epipolar lines. Epipolar lines pass through the corresponding points in images and the epipoles, i.e. $l_1 = x_1 \vee e_1$ and $l_2x = x_2 \vee e_2$. Consider that there holds

$$\vec{x}_{2\beta_2}^{\top} \mathbf{F} \vec{e}_{1\beta_1} = 0 \quad \text{and} \quad \vec{x}_{1\beta_1}^{\top} \mathbf{F}^{\top} \vec{e}_{2\beta_2} = 0 \quad (12.28)$$

$$\vec{x}_{2\beta_2}^{\top} \mathbf{F} \vec{x}_{1\beta_1} = 0 \quad \vec{x}_{1\beta_1}^{\top} \mathbf{F}^{\top} \vec{x}_{2\beta_2} = 0 \quad (12.29)$$

$$(12.30)$$

and therefore homogeneous coordinates $\vec{l}_{1\bar{\beta}_1}$, $\vec{l}_{2\bar{\beta}_2}$ of epipolar lines generated by $\vec{x}_{2\beta_2}$ and $\vec{x}_{1\beta_1}$, respectively, are obtained as

$$\vec{l}_{1\bar{\beta}_1} = \mathbf{F}^{\top} \vec{x}_{2\beta_2} \quad \text{and} \quad \vec{l}_{2\bar{\beta}_2} = \mathbf{F} \vec{x}_{1\beta_1} \quad (12.31)$$

for $\vec{x}_{2\beta_2} \neq \vec{e}_{2\beta_2}$ and $\vec{x}_{1\beta_1} \neq \vec{e}_{1\beta_1}$.

12.2 Computing epipolar geometry from image matches

Let us look at how to compute the epipolar geometry between images from image matches. Our goal is to find matrix $\mathbf{G} = \tau \mathbf{F}$ for some real non-zero τ using Equation 12.13. Let us introduce

$$\mathbf{G} = \begin{bmatrix} g_{11} & g_{12} & g_{13} \\ g_{21} & g_{22} & g_{23} \\ g_{31} & g_{32} & g_{33} \end{bmatrix} \quad (12.32)$$

and write Equation 12.13 as

$$0 = \vec{x}_{2i\beta_2}^\top \mathbf{G} \vec{x}_{1i\beta_1} = \begin{bmatrix} u_{2i} & v_{2i} & w_{2i} \end{bmatrix} \begin{bmatrix} g_{11} & g_{12} & g_{13} \\ g_{21} & g_{22} & g_{23} \\ g_{31} & g_{32} & g_{33} \end{bmatrix} \begin{bmatrix} u_{1i} \\ v_{1i} \\ w_{1i} \end{bmatrix} \quad (12.33)$$

$$0 = \begin{bmatrix} u_{2i} u_{1i} & u_{2i} v_{1i} & u_{2i} w_{1i} & v_{2i} u_{1i} & v_{2i} v_{1i} & v_{2i} w_{1i} & w_{2i} u_{1i} & w_{2i} v_{1i} & w_{2i} w_{1i} \end{bmatrix} \begin{bmatrix} g_{11} \\ g_{12} \\ \vdots \\ g_{33} \end{bmatrix}$$

for the i -th pair of the corresponding points $\vec{x}_{1i\beta_1}$, $\vec{x}_{2i\beta_2}$ in the two images. Notice that we can work even with ideal points when $w_{1i} = 0$ or $w_{2i} = 0$.

We can solve this way for a non-zero multiple of \mathbf{F} from eight correspondences in a general position, i.e. not all on a plane or on some special quadrics passing through camera centers [15]. If there is noise in image coordinates, we in general get a rank three matrix.

To avoid this problem, we can use only seven point correspondences to compute a two dimensional space of solutions

$$\mathbf{G} = \mathbf{G}_1 + \alpha \mathbf{G}_2 \quad (12.34)$$

generated from its basis \mathbf{G}_1 , \mathbf{G}_2 by α . Then we use the constraint

$$0 = |\mathbf{G}| = |\mathbf{G}_1 + \alpha \mathbf{G}_2| = \left| \begin{bmatrix} g_{111} & g_{112} & g_{113} \\ g_{121} & g_{122} & g_{123} \\ g_{131} & g_{132} & g_{133} \end{bmatrix} + \alpha \begin{bmatrix} g_{211} & g_{212} & g_{213} \\ g_{221} & g_{222} & g_{223} \\ g_{231} & g_{232} & g_{233} \end{bmatrix} \right| \quad (12.35)$$

to find α by solving a third order polynomial

$$0 = a_3 \alpha^3 + a_2 \alpha^2 + a_1 \alpha + a_0 \quad (12.36)$$

$$a_3 = |\mathbf{G}_2|$$

$$a_2 = g_{221} g_{232} g_{113} - g_{221} g_{212} g_{133} + g_{211} g_{222} g_{133} + g_{231} g_{112} g_{223} + g_{231} g_{212} g_{123} - g_{211} g_{223} g_{132} - g_{231} g_{122} g_{213} - g_{231} g_{222} g_{113} - g_{211} g_{123} g_{232} + g_{121} g_{232} g_{213} + g_{221} g_{132} g_{213} + g_{131} g_{212} g_{223} - g_{121} g_{212} g_{233} - g_{111} g_{223} g_{232} - g_{221} g_{112} g_{233} + g_{211} g_{122} g_{233} + g_{111} g_{222} g_{233} - g_{131} g_{222} g_{213}$$

$$a_1 = g_{111} g_{122} g_{233} + g_{111} g_{222} g_{133} + g_{231} g_{112} g_{123} - g_{121} g_{112} g_{233} - g_{211} g_{123} g_{132} - g_{221} g_{112} g_{133} - g_{231} g_{122} g_{113} + g_{211} g_{122} g_{133} + g_{121} g_{132} g_{213} + g_{121} g_{232} g_{113} + g_{131} g_{212} g_{123} - g_{121} g_{212} g_{133} - g_{131} g_{222} g_{113} + g_{221} g_{132} g_{113} - g_{111} g_{123} g_{232} - g_{131} g_{122} g_{213} + g_{131} g_{112} g_{223} - g_{111} g_{223} g_{132}$$

$$a_0 = |\mathbf{G}_1|$$

That will give us up to three rank two matrices \mathbf{G} .

Notice that we assumed that \mathbf{G} was constructed with a non-zero coefficient at \mathbf{G}_1 . We therefore also need to check $\mathbf{G} = \mathbf{G}_2$ for a solution.

12.3 Ambiguity in two-view reconstruction

The goal of scene reconstruction from its two views is to find camera projection matrices P_1, P_2 , and coordinates of points in the scene \vec{X}_δ such that the points \vec{X}_δ are projected by cameras P_1, P_2 to observed image points $\vec{x}_{1\beta_1}, \vec{x}_{2\beta_2}$

$$\zeta_1 \vec{x}_{1\beta_1} = P_1 \begin{bmatrix} \vec{X}_\delta \\ 1 \end{bmatrix} \quad \text{and} \quad \zeta_2 \vec{x}_{2\beta_2} = P_2 \begin{bmatrix} \vec{X}_\delta \\ 1 \end{bmatrix} \quad (12.37)$$

for some positive real ζ_1, ζ_2 .

Assume that there are some cameras P_1, P_2 , and coordinates of points in the scene \vec{X}_δ such that Equation 12.43 holds true. Then, for every 4×4 real regular matrix H we can get new camera matrices P'_1, P'_2 and new point coordinates \vec{X}'_δ as

$$P'_1 = P_1 H^{-1} \quad P'_2 = P_2 H^{-1} \quad \begin{bmatrix} \vec{X}'_\delta \\ 1 \end{bmatrix} = H \begin{bmatrix} \vec{X}_\delta \\ 1 \end{bmatrix} \quad (12.38)$$

which also project to the same image points

$$\zeta_1 \vec{x}_{1\beta_1} = P_1 \begin{bmatrix} \vec{X}_\delta \\ 1 \end{bmatrix} = P_1 H^{-1} H \begin{bmatrix} \vec{X}_\delta \\ 1 \end{bmatrix} = P'_1 \begin{bmatrix} \vec{X}'_\delta \\ 1 \end{bmatrix} \quad (12.39)$$

$$\zeta_2 \vec{x}_{2\beta_2} = P_2 \begin{bmatrix} \vec{X}_\delta \\ 1 \end{bmatrix} = P_2 H^{-1} H \begin{bmatrix} \vec{X}_\delta \\ 1 \end{bmatrix} = P'_2 \begin{bmatrix} \vec{X}'_\delta \\ 1 \end{bmatrix} \quad (12.40)$$

We see that in general we can reconstruct the cameras and the scene points only up to some unknown transformation of the space. We also see that the transformation is more general than just changing a basis in \mathbb{R}^3 where we represent affine points \vec{X}_δ . Matrix H acts in the three-dimensional affine space exactly as homography on two-dimensional affine space.

Let us next look at a somewhat simpler situation when camera calibration matrices K_1, K_2 are known. In such a case we can make sure that H has a special form which corresponds to a special change of a coordinate system in the three-dimensional affine space.

12.4 Reconstruction from two calibrated views

Let us further assume that camera calibration matrices K_1, K_2 are known. Hence we can pass from F to E using Equations 12.14, 12.15 as

$$E = K_2^\top F K_1 \quad (12.41)$$

then recover the relative pose of the cameras, set their coordinate systems and finally reconstruct points of the scene.

12.4.1 Camera computation

To simplify the setting, we will first pass from “uncalibrated” image points $\vec{x}_{1\beta_1}, \vec{x}_{2\beta_2}$ using K_1, K_2 to “calibrated”

$$\vec{x}_{1\gamma_1} = K_1^{-1} \vec{x}_{1\beta_1} \quad \text{and} \quad \vec{x}_{2\gamma_2} = K_2^{-1} \vec{x}_{2\beta_2} \quad (12.42)$$

and then use camera projection matrices as follows

$$\zeta_1 \vec{x}_{1\gamma_1} = \mathbf{P}_{1\gamma_1} \begin{bmatrix} \vec{X}_\delta \\ 1 \end{bmatrix} \quad \text{and} \quad \zeta_2 \vec{x}_{2\gamma_2} = \mathbf{P}_{2\gamma_2} \begin{bmatrix} \vec{X}_\delta \\ 1 \end{bmatrix} \quad (12.43)$$

Matrix \mathbf{H} allows us to choose the global coordinate system of the scene as (C_1, ϵ_1) . Setting

$$\mathbf{H}^{-1} = \begin{bmatrix} \mathbf{R}_1^\top & \vec{C}_{1\delta} \\ \vec{0}^\top & 1 \end{bmatrix} \quad (12.44)$$

we get from Equation 12.38

$$\mathbf{P}_{1\gamma_1} = [\mathbf{I} | \vec{0}] \quad (12.45)$$

$$\mathbf{P}_{2\gamma_2} = \left[\mathbf{R}_2 \mathbf{R}_1^\top \mid -\mathbf{R}_2 (\vec{C}_{2\delta} - \vec{C}_{1\delta}) \right] = \left[\mathbf{R}_2 \mathbf{R}_1^\top \mid -\mathbf{R}_2 \mathbf{R}_1^\top (\vec{C}_{2\epsilon_1} - \vec{C}_{1\epsilon_1}) \right] \quad (12.46)$$

$$= \left[\mathbf{R} \mid -\mathbf{R} \vec{C}_{\epsilon_1} \right] \quad (12.47)$$

and the corresponding essential matrix

$$\mathbf{E} = \mathbf{R} \left[\vec{C}_{\epsilon_1} \right]_\times \quad (12.48)$$

From image measurements, $\vec{x}_{1\gamma_1}$, $\vec{x}_{2\gamma_2}$, we can compute, Section 12.2, matrix

$$\mathbf{G} = \tau \mathbf{E} = \tau \mathbf{R} \left[\vec{C}_{\epsilon_1} \right]_\times \quad (12.49)$$

and hence we can get \mathbf{E} only up to a non-zero multiple τ . Therefore, we can recover \vec{C}_{ϵ_1} only up to τ .

We will next fix τ up to its sign s_1 . Consider that the *Frobenius norm* of a matrix \mathbf{G}

$$\begin{aligned} \|\mathbf{G}\|_F &= \sqrt{\sum_{i,j=1}^3 \mathbf{G}_{ij}^2} = \sqrt{\text{trace}(\mathbf{G}^\top \mathbf{G})} = \sqrt{\text{trace}\left(\tau^2 \left[\vec{C}_{\epsilon_1} \right]_\times^\top \mathbf{R}^\top \mathbf{R} \left[\vec{C}_{\epsilon_1} \right]_\times\right)} \\ &= \sqrt{\tau^2 \text{trace}\left(\left[\vec{C}_{\epsilon_1} \right]_\times^\top \left[\vec{C}_{\epsilon_1} \right]_\times\right)} \end{aligned} \quad (12.50)$$

$$= |\tau| \sqrt{2 \|\vec{C}_{\epsilon_1}\|^2} = |\tau| \sqrt{2} \|\vec{C}_{\epsilon_1}\| \quad (12.51)$$

We have used the following identities

$$\begin{aligned} \mathbf{G}^\top \mathbf{G} &= \tau^2 \left[\vec{C}_{\epsilon_1} \right]_\times^\top \mathbf{R}^\top \mathbf{R} \left[\vec{C}_{\epsilon_1} \right]_\times = \tau^2 \left[\vec{C}_{\epsilon_1} \right]_\times \left[\vec{C}_{\epsilon_1} \right]_\times \\ &= \tau^2 \begin{bmatrix} 0 & z & -y \\ -z & 0 & x \\ y & -x & 0 \end{bmatrix} \begin{bmatrix} 0 & -z & y \\ z & 0 & -x \\ -y & x & 0 \end{bmatrix} = \tau^2 \begin{bmatrix} y^2 + z^2 & -xy & -xz \\ -xy & x^2 + z^2 & yz \\ -xz & -yz & x^2 + y^2 \end{bmatrix} \end{aligned} \quad (12.52)$$

We can now construct normalized matrix $\bar{\mathbf{G}}$ as

$$\bar{\mathbf{G}} = \frac{\sqrt{2} \mathbf{G}}{\sqrt{\sum_{i,j=1}^3 \mathbf{G}_{ij}^2}} = \frac{\tau}{|\tau|} \mathbf{R} \left[\frac{\vec{C}_{\epsilon_1}}{\|\vec{C}_{\epsilon_1}\|} \right]_\times = s_1 \mathbf{R} \left[\vec{t}_{\epsilon_1} \right]_\times \quad (12.53)$$

with new unknown $s_1 \in \{+1, -1\}$ and \vec{t}_{ϵ_1} denoting the unit vector in the direction of the second camera center in ϵ_1 basis.

We can find vector $\vec{v}_{\epsilon_1} = s_2 \vec{t}_{\epsilon_1}$ with new unknown $s_2 \in \{+1, -1\}$ by solving

$$\bar{\mathbf{G}} \vec{v}_{\epsilon_1} = 0 \quad \text{subject to} \quad \|\vec{v}_{\epsilon_1}\| = 1 \quad (12.54)$$

to get

$$\bar{\mathbf{G}} = s_1 \mathbf{R} \begin{bmatrix} 1 \\ s_2 \vec{v}_{\epsilon_1} \end{bmatrix}_{\times} = \frac{s_1}{s_2} \mathbf{R} [\vec{v}_{\epsilon_1}]_{\times} \quad (12.55)$$

$$s \bar{\mathbf{G}} = \mathbf{R} [\vec{v}_{\epsilon_1}]_{\times} \quad (12.56)$$

$$\begin{bmatrix} s \mathbf{g}_1 & s \mathbf{g}_2 & s \mathbf{g}_3 \end{bmatrix} = \mathbf{R} \begin{bmatrix} \mathbf{v}_1 & \mathbf{v}_2 & \mathbf{v}_3 \end{bmatrix} \quad (12.57)$$

with unknown $s \in \{+1, -1\}$, unknown rotation \mathbf{R} and known matrices $\begin{bmatrix} \mathbf{g}_1 & \mathbf{g}_2 & \mathbf{g}_3 \end{bmatrix} = \bar{\mathbf{G}}$ and $\begin{bmatrix} \mathbf{v}_1 & \mathbf{v}_2 & \mathbf{v}_3 \end{bmatrix} = [\vec{v}_{\epsilon_1}]_{\times}$.

This is a matricial equation. Matrices $\bar{\mathbf{G}}, [\vec{v}_{\epsilon_1}]_{\times}$ are of rank two and hence do not determine \mathbf{R} uniquely unless we use $\mathbf{R}^T \mathbf{R} = \mathbf{I}$ and $|\mathbf{R}| = 1$. That leads to a set of polynomial equations. They can be solved but we will use the property of vector product, § 2, to directly construct regular matrices that will determine \mathbf{R} uniquely for a fixed s .

Consider that for every regular $\mathbf{A} \in \mathbb{R}^{3 \times 3}$, we have, § 2,

$$(\mathbf{A} \vec{x}_{\beta}) \times (\mathbf{A} \vec{y}_{\beta}) = \vec{x}_{\beta'} \times \vec{y}_{\beta'} = \frac{\mathbf{A}^{-T}}{|\mathbf{A}^{-T}|} (\vec{x}_{\beta} \times \vec{y}_{\beta}) \quad (12.58)$$

which for \mathbf{R} gives

$$(\mathbf{R} \vec{x}_{\beta}) \times (\mathbf{R} \vec{y}_{\beta}) = \mathbf{R} (\vec{x}_{\beta} \times \vec{y}_{\beta}) \quad (12.59)$$

Using it for $i, j = 1, 2, 3$ to get

$$(s \mathbf{g}_i) \times (s \mathbf{g}_j) = (\mathbf{R} \mathbf{v}_i) \times (\mathbf{R} \mathbf{v}_j) \quad (12.60)$$

$$s^2 (\mathbf{g}_i \times \mathbf{g}_j) = \mathbf{R} (\mathbf{v}_i \times \mathbf{v}_j) \quad (12.61)$$

$$(\mathbf{g}_i \times \mathbf{g}_j) = \mathbf{R} (\mathbf{v}_i \times \mathbf{v}_j) \quad (12.62)$$

i.e. three more vector equations. Notice how s disappeared in the vector product.

We see that we can write

$$\begin{bmatrix} s \mathbf{g}_1 & s \mathbf{g}_2 & s \mathbf{g}_3 & \mathbf{g}_1 \times \mathbf{g}_2 & \mathbf{g}_2 \times \mathbf{g}_3 & \mathbf{g}_1 \times \mathbf{g}_3 \end{bmatrix} = \\ = \mathbf{R}_s \begin{bmatrix} \mathbf{v}_1 & \mathbf{v}_2 & \mathbf{v}_3 & \mathbf{v}_1 \times \mathbf{v}_2 & \mathbf{v}_2 \times \mathbf{v}_3 & \mathbf{v}_1 \times \mathbf{v}_3 \end{bmatrix} \quad (12.63)$$

There are two solutions \mathbf{R}_+ for $s = +1$ and \mathbf{R}_- for $s = -1$. We can next compute two solutions $\vec{t}_{+\epsilon_1} = +\vec{v}_{\epsilon_1}$ and $\vec{t}_{-\epsilon_1} = -\vec{v}_{\epsilon_1}$ and combine them together to four possible solutions

$$\mathbf{P}_{2\gamma_2++} = \mathbf{R}_+ \left[\mathbf{I} \mid -\vec{t}_{+\epsilon_1} \right] \quad (12.64)$$

$$\mathbf{P}_{2\gamma_2+-} = \mathbf{R}_+ \left[\mathbf{I} \mid -\vec{t}_{-\epsilon_1} \right] \quad (12.65)$$

$$\mathbf{P}_{2\gamma_2--} = \mathbf{R}_- \left[\mathbf{I} \mid -\vec{t}_{+\epsilon_1} \right] \quad (12.66)$$

$$\mathbf{P}_{2\gamma_2--} = \mathbf{R}_- \left[\mathbf{I} \mid -\vec{t}_{-\epsilon_1} \right] \quad (12.67)$$

The above four camera projection matrices are compatible with $\bar{\mathbf{G}}$. The one which corresponds to the actual matrix can be selected by requiring that all reconstructed points lie in front of the cameras, i.e. that the reconstructed points are all positive multiples of vectors $\vec{x}_{1\epsilon_1}$ and $\vec{x}_{2\epsilon_2}$ for all image points.

12.4.2 Point computation

Let us assume having camera projection matrices P_1, P_2 and image points $\vec{x}_{1\beta_1}, \vec{x}_{2\beta_2}$ such that

$$\zeta_1 \vec{x}_{1\beta_1} = P_1 \begin{bmatrix} \vec{X}_\delta \\ 1 \end{bmatrix} \quad \text{and} \quad \zeta_2 \vec{x}_{2\beta_2} = P_2 \begin{bmatrix} \vec{X}_\delta \\ 1 \end{bmatrix} \quad (12.68)$$

We can get \vec{X}_δ , and ζ_1, ζ_2 by solving the following system of (inhomogeneous) linear equations

$$\begin{bmatrix} \vec{x}_{1\beta_1} & \vec{0} & -P_1 \\ \vec{0} & \vec{x}_{2\beta_2} & -P_2 \end{bmatrix} \begin{bmatrix} \zeta_1 \\ \zeta_2 \\ \vec{X}_\delta \\ 1 \end{bmatrix} = 0 \quad (12.69)$$

12.5 Calibrated relative camera pose computation

In the previous chapter, we had first computed a multiple of the fundamental matrix from seven point correspondences and only then used camera calibration matrices to recover a multiple of the essential matrix. Here we will use the camera calibration right from the beginning to obtain a multiple of the essential matrix directly from only five image correspondences. Not only that five is smaller than seven but using the calibration right from the beginning permits all points of the scene generating the correspondences to lie in a plane.

We start from Equation 12.42 to get $\vec{x}_{1\gamma_1}$ and $\vec{x}_{2\gamma_2}$ from Equation 12.43 which are related by

$$\vec{x}_{2\beta_2}^\top K_2^{-\top} E K_1^{-1} \vec{x}_{1\beta_1} = 0 \quad (12.70)$$

$$\vec{x}_{2\gamma_2}^\top E \vec{x}_{1\gamma_1} = 0 \quad (12.71)$$

The above equation holds true for all pairs of image points $(\vec{x}_{1\gamma_1}, \vec{x}_{2\gamma_2})$ that are in correspondence, i.e. are projections of the same point of the scene.

12.5.1 Constraints on E

Matrix E has rank two, and therefore there holds

$$|\mathbf{E}| = 0 \quad (12.72)$$

true.

We will now derive additional constraints on E. Let us consider that we can write, Equation 12.48,

$$\mathbf{E} = \mathbf{R} \left[\vec{C}_{\epsilon_1} \right]_{\times} \quad (12.73)$$

Let us introduce $\vec{C}_{\epsilon_1} = [x \ y \ z]^\top$ and evaluate

$$\begin{aligned}
 \mathbf{E}^\top \mathbf{E} &= \left(\mathbf{R} \left[\vec{C}_{\epsilon_1} \right]_{\times} \right)^\top \mathbf{R} \left[\vec{C}_{\epsilon_1} \right]_{\times} = \left[\vec{C}_{\epsilon_1} \right]_{\times}^\top \mathbf{R}^\top \mathbf{R} \left[\vec{C}_{\epsilon_1} \right]_{\times} = \left[\vec{C}_{\epsilon_1} \right]_{\times}^\top \left[\vec{C}_{\epsilon_1} \right]_{\times} \\
 &= \begin{bmatrix} 0 & z & -y \\ -z & 0 & x \\ y & -x & 0 \end{bmatrix} \begin{bmatrix} 0 & -z & y \\ z & 0 & -x \\ -y & x & 0 \end{bmatrix} = \begin{bmatrix} z^2 + y^2 & -xy & -xz \\ -xy & z^2 + x^2 & -yz \\ -xz & -yz & y^2 + x^2 \end{bmatrix} \\
 &= \begin{bmatrix} x^2 + y^2 + z^2 & & \\ & x^2 + y^2 + z^2 & \\ & & x^2 + y^2 + z^2 \end{bmatrix} - \begin{bmatrix} xx & xy & xz \\ xy & yy & yz \\ xz & yz & zz \end{bmatrix} \\
 &= \|\vec{C}_{\epsilon_1}\|^2 \mathbf{I} - \vec{C}_{\epsilon_1} \vec{C}_{\epsilon_1}^\top
 \end{aligned} \tag{12.74}$$

We can multiply the above expression by \mathbf{E} from the left again to get an interesting equation

$$\mathbf{E} \mathbf{E}^\top \mathbf{E} = \mathbf{E} \left(\|\vec{C}_{\epsilon_1}\|^2 \mathbf{I} - \vec{C}_{\epsilon_1} \vec{C}_{\epsilon_1}^\top \right) = \|\vec{C}_{\epsilon_1}\|^2 \mathbf{E} = \frac{1}{2} \text{trace}(\mathbf{E}^\top \mathbf{E}) \mathbf{E} \tag{12.76}$$

or equivalently

$$2 \mathbf{E} \mathbf{E}^\top \mathbf{E} = \text{trace}(\mathbf{E}^\top \mathbf{E}) \mathbf{E} \tag{12.77}$$

which provides nine equations on elements of \mathbf{E} .

In fact, these equations also imply $|\mathbf{E}| = 0$. Consider that Equation 12.77 implies

$$(2 \mathbf{E} \mathbf{E}^\top - \text{trace}(\mathbf{E}^\top \mathbf{E}) \mathbf{I}) \mathbf{E} = 0 \tag{12.78}$$

For Equation 12.78 to hold true, either \mathbf{E} can't have the full rank, i.e. $|\mathbf{E}| = 0$, or $2 \mathbf{E} \mathbf{E}^\top - \text{trace}(\mathbf{E}^\top \mathbf{E}) \mathbf{I} = 0$. The latter case gives

$$0 = \text{trace}(2 \mathbf{E} \mathbf{E}^\top - \text{trace}(\mathbf{E}^\top \mathbf{E}) \mathbf{I}) = 2 \text{trace}(\mathbf{E} \mathbf{E}^\top) - 3 \text{trace}(\mathbf{E}^\top \mathbf{E}) \tag{12.79}$$

Let us check the relationship between $\text{trace}(\mathbf{E}^\top \mathbf{E})$ and $\text{trace}(\mathbf{E} \mathbf{E}^\top)$ now. We write

$$\begin{aligned}
 \text{trace}(\mathbf{E}^\top \mathbf{E}) &= (\mathbf{E}_{11}^2 + \mathbf{E}_{21}^2 + \mathbf{E}_{31}^2) + (\mathbf{E}_{12}^2 + \mathbf{E}_{22}^2 + \mathbf{E}_{32}^2) + (\mathbf{E}_{13}^2 + \mathbf{E}_{23}^2 + \mathbf{E}_{33}^2) \\
 &= (\mathbf{E}_{11}^2 + \mathbf{E}_{12}^2 + \mathbf{E}_{13}^2) + (\mathbf{E}_{21}^2 + \mathbf{E}_{22}^2 + \mathbf{E}_{23}^2) + (\mathbf{E}_{31}^2 + \mathbf{E}_{32}^2 + \mathbf{E}_{33}^2) \\
 &= \text{trace}(\mathbf{E} \mathbf{E}^\top)
 \end{aligned} \tag{12.80}$$

Substituting the above into Equation 12.79 gets us

$$0 = 2 \text{trace}(\mathbf{E} \mathbf{E}^\top) - 3 \text{trace}(\mathbf{E}^\top \mathbf{E}) = -\text{trace}(\mathbf{E}^\top \mathbf{E}) \tag{12.81}$$

Equation $2 \mathbf{E} \mathbf{E}^\top - \text{trace}(\mathbf{E}^\top \mathbf{E}) \mathbf{I} = 0$ also implies

$$2 \mathbf{E} \mathbf{E}^\top = \text{trace}(\mathbf{E}^\top \mathbf{E}) \mathbf{I} \tag{12.82}$$

$$|2 \mathbf{E} \mathbf{E}^\top| = |\text{trace}(\mathbf{E}^\top \mathbf{E}) \mathbf{I}| \tag{12.83}$$

$$2^3 |\mathbf{E}|^2 = (\text{trace}(\mathbf{E}^\top \mathbf{E}))^3 \tag{12.84}$$

$$2^3 |\mathbf{E}|^2 = 0 \tag{12.85}$$

$$|\mathbf{E}| = 0 \tag{12.86}$$

Therefore, Equation 12.77 implies $|\mathbf{E}| = 0$.

Let us now look at constraints on matrix $\mathbf{G} = \tau \mathbf{E}$, for some non-zero real τ . We can multiply Equation 12.78 by τ^3 to get

$$\tau^3 (2 \mathbf{E} \mathbf{E}^\top - \text{trace}(\mathbf{E}^\top \mathbf{E}) \mathbf{I}) \mathbf{E} = 0 \quad (12.87)$$

$$(2 (\tau \mathbf{E}) (\tau \mathbf{E}^\top) - \text{trace}((\tau \mathbf{E}^\top) (\tau \mathbf{E})) \mathbf{I}) (\tau \mathbf{E}) = 0 \quad (12.88)$$

$$(2 \mathbf{G} \mathbf{G}^\top - \text{trace}(\mathbf{G}^\top \mathbf{G}) \mathbf{I}) \mathbf{G} = 0 \quad (12.89)$$

Clearly, $\text{rank}(\mathbf{G}) = \text{rank}(\tau \mathbf{E}) = \text{rank}(\mathbf{E}) = 2$.

We conclude that constraints on \mathbf{E} and \mathbf{G} are the same.

12.5.2 Geometrical interpretation of Equation 12.77

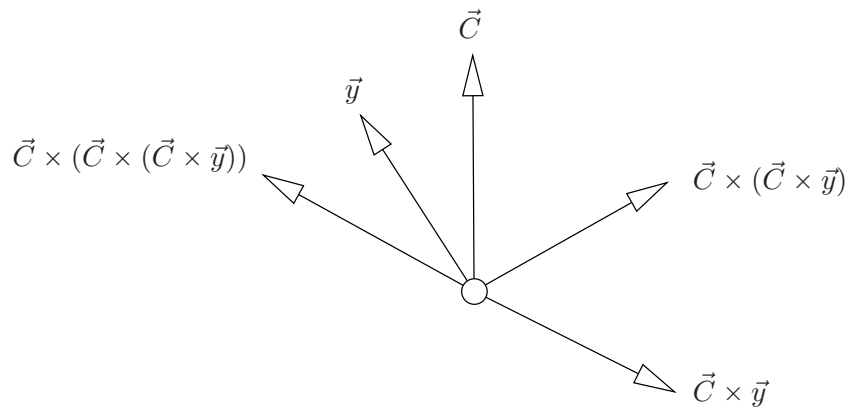

Figure 12.3: Identity $\vec{C}_{\epsilon_1} \times (\vec{C}_{\epsilon_1} \times (\vec{C}_{\epsilon_1} \times \vec{y})) = -\|\vec{C}_{\epsilon_1}\|^2 (\vec{C}_{\epsilon_1} \times \vec{y})$.

Let us provide a geometrical interpretation of Equation 12.77. We will multiply both sides of Equation 12.77 by a vector $\vec{y} \in \mathbb{R}^3$ and write

$$2 \mathbf{E} \mathbf{E}^\top \mathbf{E} \vec{y} = \text{trace}(\mathbf{E}^\top \mathbf{E}) \mathbf{E} \vec{y} \quad (12.90)$$

$$2 \mathbf{R} \begin{bmatrix} \vec{C}_{\epsilon_1} \end{bmatrix}_\times \begin{bmatrix} \vec{C}_{\epsilon_1} \end{bmatrix}_\times^\top \begin{bmatrix} \vec{C}_{\epsilon_1} \end{bmatrix}_\times \vec{y} = 2 \|\vec{C}_{\epsilon_1}\|^2 \mathbf{R} \begin{bmatrix} \vec{C}_{\epsilon_1} \end{bmatrix}_\times \vec{y} \quad (12.91)$$

$$-\mathbf{R} \begin{bmatrix} \vec{C}_{\epsilon_1} \end{bmatrix}_\times \begin{bmatrix} \vec{C}_{\epsilon_1} \end{bmatrix}_\times \begin{bmatrix} \vec{C}_{\epsilon_1} \end{bmatrix}_\times \vec{y} = \mathbf{R} \|\vec{C}_{\epsilon_1}\|^2 \begin{bmatrix} \vec{C}_{\epsilon_1} \end{bmatrix}_\times \vec{y} \quad (12.92)$$

$$\begin{bmatrix} \vec{C}_{\epsilon_1} \end{bmatrix}_\times \begin{bmatrix} \vec{C}_{\epsilon_1} \end{bmatrix}_\times \begin{bmatrix} \vec{C}_{\epsilon_1} \end{bmatrix}_\times \vec{y} = -\|\vec{C}_{\epsilon_1}\|^2 \begin{bmatrix} \vec{C}_{\epsilon_1} \end{bmatrix}_\times \vec{y} \quad (12.93)$$

Now, we use that for every two vectors $\vec{x}, \vec{y} \in \mathbb{R}^3$ there holds $[\vec{x}]_\times \vec{y} = \vec{x} \times \vec{y}$ true to get

$$\vec{C}_{\epsilon_1} \times (\vec{C}_{\epsilon_1} \times (\vec{C}_{\epsilon_1} \times \vec{y})) = -\|\vec{C}_{\epsilon_1}\|^2 (\vec{C}_{\epsilon_1} \times \vec{y}) \quad (12.94)$$

which is a familiar identity of the vector product in \mathbb{R}^3 , Figure 12.3.

12.5.3 Characterization of E

Let us next see that a non-zero 3×3 real matrix satisfying Equation 12.77 has rank two and can be written in the form of Equation 12.73 for some rotation R and some vector C_{ϵ_1} .

Consider a real 3×3 matrix E such that Equation 12.77 holds true. We will make here use of the SVD decomposition [5, p. 411] of real matrices. We can write

$$E = U \begin{bmatrix} a & & \\ & b & \\ & & c \end{bmatrix} V^T \quad (12.95)$$

for some real non-negative a, b, c and some orthogonal real 3×3 matrices U, V , such that $U^T U = I$, and $V^T V = I$ [5, p. 411]. One can see that $U^T U = I$, and $V^T V = I$ implies $|U| = \pm 1, |V| = \pm 1$.

Using Equation 12.95 we get

$$E E^T = U \begin{bmatrix} a^2 & & \\ & b^2 & \\ & & c^2 \end{bmatrix} U^T, \quad E^T E = V \begin{bmatrix} a^2 & & \\ & b^2 & \\ & & c^2 \end{bmatrix} V^T \quad (12.96)$$

and $\text{trace}(E^T E) = \text{trace}(V D^2 V^T) = \text{trace}(V D^2 V^{-1}) = \text{trace}(D^2)$ since matrices D^2 and $E E^T$ are similar and hence their traces, which are the sums of their eigenvalues, are equal. Now, we can rewrite Equation 12.77 as

$$\left(2U \begin{bmatrix} a^2 & & \\ & b^2 & \\ & & c^2 \end{bmatrix} U^T - (a^2 + b^2 + c^2) I \right) U \begin{bmatrix} a & & \\ & b & \\ & & c \end{bmatrix} V^T = 0 \quad (12.97)$$

$$2U \begin{bmatrix} a^3 & & \\ & b^3 & \\ & & c^3 \end{bmatrix} V^T - (a^2 + b^2 + c^2) U \begin{bmatrix} a & & \\ & b & \\ & & c \end{bmatrix} V^T = 0 \quad (12.98)$$

Matrices U, V are regular and thus we get

$$2 \begin{bmatrix} a^3 & & \\ & b^3 & \\ & & c^3 \end{bmatrix} - (a^2 + b^2 + c^2) \begin{bmatrix} a & & \\ & b & \\ & & c \end{bmatrix} = 0 \quad (12.99)$$

which finally leads to the following three equations

$$a^3 - a b^2 - a c^2 = a(a^2 - b^2 - c^2) = 0 \quad (12.100)$$

$$b^3 - b a^2 - b c^2 = b(b^2 - c^2 - a^2) = 0 \quad (12.101)$$

$$c^3 - c a^2 - c b^2 = c(c^2 - a^2 - b^2) = 0 \quad (12.102)$$

We see that there are the following two exclusive cases:

1. If any two of a, b, c are zero, then the third one is zero too. For instance, if $a = b = 0$, then Equation 12.102 gives $c^3 = 0$. This can't happen for a non-zero E .
2. If any two of a, b, c are non-zero, then the two non-zero are equal and the third is zero. For instance, if $a \neq 0$ and $b \neq 0$, then Equations 12.100, 12.101 imply $c^2 = 0$ and thus $a^2 = b^2$, which gives $a = b$ since a, b are non-negative, i.e. $\text{rank}(E) = 2$.

We thus conclude that \mathbf{E} can be written as

$$\mathbf{E} = \mathbf{U} \begin{bmatrix} a & & \\ & a & \\ & & 0 \end{bmatrix} \mathbf{V}^\top = \mathbf{U} \begin{bmatrix} 0 & 1 & 0 \\ -1 & 0 & 0 \\ 0 & 0 & 1 \end{bmatrix} \begin{bmatrix} 0 & -a & 0 \\ a & 0 & 0 \\ 0 & 0 & 0 \end{bmatrix} \mathbf{V}^\top \quad (12.103)$$

$$= \mathbf{W} \begin{bmatrix} 0 \\ 0 \\ a \end{bmatrix}_\times \mathbf{V}^\top = \mathbf{W} \begin{bmatrix} \mathbf{V}^\top \mathbf{V} & \begin{bmatrix} 0 \\ 0 \\ a \end{bmatrix}_\times \end{bmatrix} \mathbf{V}^\top = \mathbf{W} \frac{(\mathbf{V}^\top)^{-\top}}{|(\mathbf{V}^\top)^{-\top}|} \begin{bmatrix} \mathbf{V} & \begin{bmatrix} 0 \\ 0 \\ a \end{bmatrix}_\times \end{bmatrix} \quad (12.104)$$

$$= (\text{sign}(|\mathbf{W}|))^2 \mathbf{W} \mathbf{V}^\top \text{sign}(|\mathbf{V}^\top|) [a \mathbf{v}_3]_\times \quad (12.105)$$

$$= \text{sign}(|\mathbf{W}|) \mathbf{W} \mathbf{V}^\top \text{sign}(|\mathbf{V}^\top|) [\text{sign}(|\mathbf{W}|) a \mathbf{v}_3]_\times \quad (12.106)$$

$$= \mathbf{R} [\text{sign}(|\mathbf{U}|) a \mathbf{v}_3]_\times \quad (12.107)$$

for some non-negative a and the third column \mathbf{v}_3 of \mathbf{V} . Parameter a is zero for $\mathbf{E} = 0$ and positive for rank two matrices \mathbf{E} . We introduced a new matrix \mathbf{W} in Equation 12.104, which is the product of \mathbf{U} and a rotation round the z axis. We also used $\mathbf{V}^\top \mathbf{V} = \mathbf{I}$, and finally Equation 2.51. In Equation 12.105 we used $(\text{sign}(|\mathbf{W}|))^2 = 1$, $\mathbf{V}^{-\top} = \mathbf{V}$ for $\mathbf{V}^\top \mathbf{V} = \mathbf{I}$. Matrix $\mathbf{R} = \text{sign}(|\mathbf{W}|) \mathbf{W} \mathbf{V}^\top \text{sign}(|\mathbf{V}^\top|)$ in Equation 12.107 is a rotation since $\text{sign}(|\mathbf{W}|) \mathbf{W}$ as well as $\mathbf{V}^\top \text{sign}(|\mathbf{V}^\top|)$ are both rotations. Finally, we see that $\text{sign}(|\mathbf{W}|) = \text{sign}(|\mathbf{U}|)$.

12.5.4 Computing a non-zero multiple of \mathbf{E}

Let us now discuss how to compute a non-zero multiple of matrix \mathbf{E} from image matches.

12.5.4.1 Selecting equations

Every pair of image matches $(\vec{x}_{1\gamma_1}, \vec{x}_{2\gamma_2})$ provides a linear constraint on elements of \mathbf{E} in the form of Equation 12.71 and matricial Equation 12.77 gives nine polynomial constraints for elements of \mathbf{E} .

We have already seen in Paragraph 12.2 that a non-zero multiple of \mathbf{E} can be obtained from seven absolutely accurate point correspondences using the constraint $|\mathbf{E}| = 0$. The solution was obtained by solving a set of polynomial equations out of which seven were linear and the eighth one was a third order polynomial.

Let us now see how to exploit Equation 12.77 in order to compute a non-zero multiple of \mathbf{E} from as few image matches as possible.

An idea might be to use Equations 12.77 instead of $|\mathbf{E}| = 0$. It would be motivated by the fact that Equations 12.77 imply equation $|\mathbf{E}| = 0$ for real 3×3 matrices \mathbf{E} . Unfortunately, this implication does not hold true when we allow complex numbers in \mathbf{E}^1 , which we have to do if we

¹Equation $|\mathbf{E}| = 0$ can't be generated from Equations 12.77 as their algebraic combination, i.e. $|\mathbf{E}| = 0$ is not in the ideal [2] generated by Equations 12.77. It means that there might be some matrices \mathbf{E} satisfying Equations 12.77 which do not satisfy $|\mathbf{E}| = 0$. We know that such matrices can't be real. The proof of the above claim can be obtained by the following program in Maple [18]

```
>with(LinearAlgebra):
>with(Groebner):
>E:=<<e11|e12|e13>,<e21|e22|e23>,<e31|e32|e33>>:
>eM:=2*E.Transpose(E).E-Trace(Transpose(E).E)*E:
>eq:=expand(convert(convert(eM,Vector),list)):
>v:=indets(eq):
```

want to obtain \mathbf{E} as a solution to a polynomial system without using any additional constraints. We have to therefore use $|\mathbf{E}| = 0$ as well.

The next question is whether we have to use all nine Equations 12.77. It can be shown similarly as above that indeed none of the equations 12.77 is in the ideal [2] generated by the others². Therefore, we have to use all Equations 12.77 as well as $|\mathbf{E}| = 0$. Hence we have altogether ten polynomial equations of order higher than one.

We have more equations than unknowns but they still do not fully determine \mathbf{E} . We have to add some more equations from image matches. To see how many equations we have to add, we evaluate the Hilbert dimension [2] of the ideal generated by Equations 12.77 and $|\mathbf{E}| = 0$. We know [2] that a system of polynomial equations has a finite number of solutions if and only if the Hilbert dimension of the ideal generated by the system is zero.

The Hilbert dimension of the ideal generated by Equations 12.77 and $|\mathbf{E}| = 0$ is equal to

```
>mo:=tdeg(op(v)):
>G:=Basis(eq,mo):
>Reduce(Determinant(E),G,mo);
e11 e22 e33 - e11 e23 e32 + e21 e32 e13 - e21 e12 e33 + e31 e12 e23 - e31 e22 e13
```

which computes the Groebner basis \mathbf{G} of the ideal generated by Equations 12.77 and verifies that the remainder on division of $|\mathbf{E}|$ by \mathbf{G} is non-zero [2].

²To show that none of the equations 12.77 is in the ideal generated by the others, we run the following test in Maple.

```
>with(LinearAlgebra):
>with(Groebner):
>E:=<<e11|e12|e13>, <e21|e22|e23>, <e31|e32|e33>>;
>eM:=2*E.Transpose(E).E-Trace(Transpose(E).E)*E;
>eq:=expand(convert(convert(eM,Vector),list)):
>
>ReduceEqByEqn:=proc(eq,eqn)
    local mo,G;
    mo:=tdeg(op(indets(eqn)));
    G:=Basis(eqn,mo);
    Reduce(eq,G,mo);
end proc;
>
>for i from 1 to 9 do
    ReduceEqByEqn(eq[i],eq[[op({$1..9} minus {i})]]);
end;
```

```
e113 + e11 e122 + e11 e132 + e11 e212 + 2 e21 e12 e22 + 2 e21 e13 e23 + e11 e312 + 2 e31 e12 e32 + 2 e31 e13 e33 - e11 e222 - e11 e322 - e11 e232 - e11 e332
e112 e21 + 2 e11 e12 e22 + 2 e11 e13 e23 + e213 + e21 e222 + e21 e232 + e21 e312 + 2 e31 e22 e32 + 2 e31 e23 e33 - e21 e122 - e21 e322 - e21 e132 - e21 e332
e112 e31 + 2 e11 e12 e32 + 2 e11 e13 e33 + e212 e31 + 2 e21 e22 e32 + 2 e21 e23 e33 + e313 + e31 e322 + e31 e332 - e31 e122 - e31 e222 - e31 e132 - e31 e232
e12 e112 + e123 + e12 e132 + 2 e22 e11 e21 + e12 e222 + 2 e22 e13 e23 + 2 e32 e11 e31 + e12 e322 + 2 e32 e13 e33 - e12 e212 - e12 e312 - e12 e232 - e12 e332
2 e12 e11 e21 + e122 e22 + 2 e12 e13 e23 + e22 e212 + e223 + e22 e232 + 2 e32 e21 e31 + e22 e322 + 2 e32 e23 e33 - e22 e112 - e22 e312 - e22 e132 - e22 e332
2 e12 e11 e31 + e122 e32 + 2 e12 e13 e33 + 2 e22 e21 e31 + e222 e32 + 2 e22 e23 e33 + e32 e312 + e323 + e32 e332 - e32 e112 - e32 e212 - e32 e132 - e32 e232
e13 e112 + e13 e122 + e133 + 2 e23 e11 e21 + 2 e23 e12 e22 + e13 e232 + 2 e33 e11 e31 + 2 e33 e12 e32 + e13 e332 - e13 e212 - e13 e312 - e13 e222 - e13 e322
2 e13 e11 e21 + 2 e13 e12 e22 + e132 e23 + e23 e212 + e23 e222 + e233 + 2 e33 e21 e31 + 2 e33 e22 e32 + e23 e332 - e23 e112 - e23 e312 - e23 e122 - e23 e322
2 e13 e11 e31 + 2 e13 e12 e32 + e132 e33 + 2 e23 e21 e31 + 2 e23 e22 e32 + e232 e33 + e33 e312 + e33 e322 + e333 - e33 e112 - e33 e212 - e33 e122 - e33 e222
```

six³. An extra linear equation reduces the Hilbert dimension by one [2]. Hence, five additional (independent) linear equations from image matches will reduce the Hilbert dimension of the system to one.

Since all equations 12.71, 12.77 and $|\mathbf{E}| = 0$ are homogeneous, we can't reduce the Hilbert dimension below one by adding more equations 12.77 from image matches. This reflects the fact that \mathbf{E} is fixed by image measurements only up to a non-zero scale.

To conclude, five independent linear equations 12.71 plus Equations 12.77 and $|\mathbf{E}| = 0$ fix \mathbf{E} up to a non-zero scale.

The scale of \mathbf{E} has to be fixed in a different way. For instance, one often knows that some of the elements of \mathbf{E} can be set to one. By doing so, an extra independent linear equation is obtained and the Hilbert dimension is reduced to zero. Alternatively, one can ask for $\|\mathbf{E}\|^2 = 1$, which adds a second order equation. That also reduces the Hilbert dimension to zero but doubles the number of solutions for \mathbf{E} .

12.5.4.2 Solving the equations

We will next describe one way how to solve equations

$$\vec{x}_{i,2\gamma_2}^\top \mathbf{E} \vec{x}_{i,1\gamma_1} = 0, \quad (2\mathbf{E}\mathbf{E}^\top - \text{trace}(\mathbf{E}^\top \mathbf{E}) \mathbf{I}) \mathbf{E} = 0, \quad |\mathbf{E}| = 0, \quad i = 1, \dots, 5 \quad (12.108)$$

We will present a solution based on [19], which is somewhat less efficient than [20, 21] but requires only eigenvalue computation.

First, using Equation 2.90 from Paragraph 2.5, we can write

$$\begin{bmatrix} \vec{x}_{1,1\gamma_1}^\top \otimes \vec{x}_{1,2\gamma_2}^\top \\ \vec{x}_{2,1\gamma_1}^\top \otimes \vec{x}_{2,2\gamma_2}^\top \\ \vec{x}_{3,1\gamma_1}^\top \otimes \vec{x}_{3,2\gamma_2}^\top \\ \vec{x}_{4,1\gamma_1}^\top \otimes \vec{x}_{4,2\gamma_2}^\top \\ \vec{x}_{5,1\gamma_1}^\top \otimes \vec{x}_{5,2\gamma_2}^\top \\ \vec{a}^\top \end{bmatrix} v(\mathbf{E}) = \begin{bmatrix} 0 \\ 0 \\ 0 \\ 0 \\ 0 \\ 1 \end{bmatrix} \quad (12.109)$$

to obtain a 6×9 matrix of a system of linear equations on $v(\mathbf{E})$. Row \vec{a}^\top can be chosen randomly to fix the scale of $v(\mathbf{E})$. There is only a negligible chance that it will be chosen in the orthogonal complement of the span of the solutions to force the solutions be trivial. If so, it can be detected and a new \vec{a}^\top generated.

Assuming that the rows of the matrix of the system are linearly independent, we obtain a 3-dimensional affine space of solutions. After rearranging the particular solution, resp. the basis of the solution of the associated homogeneous system, back to 3×3 matrices \mathbf{G}_0 , resp. $\mathbf{G}_1, \mathbf{G}_2, \mathbf{G}_3$, we will get all solutions compatible with Equation 12.109 in the form

$$\mathbf{G} = \mathbf{G}_0 + x \mathbf{G}_1 + y \mathbf{G}_2 + z \mathbf{G}_3 \quad (12.110)$$

³The Hilbert Dimension of the ideal is computed in Maple as follows

```
>with(LinearAlgebra):
>E:=<<e11|e12|e13>, <e21|e22|e23>, <e31|e32|e33>>:
>eM:=2*E.Transpose(E).E-Trace(Transpose(E).E)*E:
>eq:=expand(convert(convert(eM,Vector),list)):
>with(PolynomialIdeals):
>HilbertDimension(<op(eq),Determinant(E)>);
```

for $x, y, z \in \mathbb{R}$.

Now, we can substitute \mathbf{G} for \mathbf{E} into the two remaining equations in 12.108. We get ten third-order polynomial equations in three unknowns and with 20 monomials. We can write it as

$$\mathbf{M}\mathbf{m} = 0 \quad (12.111)$$

where \mathbf{M} is a constant 10×20 matrix⁴ and

$$\mathbf{m}^\top = [x^3, yx^2, y^2x, y^3, zx^2, zyx, zy^2, z^2x, z^2y, z^3, x^2, yx, y^2, zx, zy, z^2, x, y, z, 1] \quad (12.112)$$

is a vector of 20 monomials.

Next, we rewrite the system 12.112 as

$$(z^3\mathbf{C}_3 + z^2\mathbf{C}_2 + z\mathbf{C}_1 + \mathbf{C}_0)\mathbf{c} = 0 \quad (12.113)$$

with

$$\mathbf{C} = z^3\mathbf{C}_3 + z^2\mathbf{C}_2 + z\mathbf{C}_1 + \mathbf{C}_0 \quad (12.114)$$

containing 10 monomials. Matrices $\mathbf{C}_0, \dots, \mathbf{C}_4$ are constant 10×10 matrices

$$\mathbf{C}_0 = [\mathbf{m}_1 \ \mathbf{m}_2 \ \mathbf{m}_3 \ \mathbf{m}_4 \ \mathbf{m}_{11} \ \mathbf{m}_{12} \ \mathbf{m}_{13} \ \mathbf{m}_{17} \ \mathbf{m}_{18} \ \mathbf{m}_{20}] \quad (12.115)$$

$$\mathbf{C}_1 = [0 \ 0 \ 0 \ 0 \ \mathbf{m}_5 \ \mathbf{m}_6 \ \mathbf{m}_7 \ \mathbf{m}_{14} \ \mathbf{m}_{15} \ \mathbf{m}_{19}] \quad (12.116)$$

$$\mathbf{C}_2 = [0 \ 0 \ 0 \ 0 \ 0 \ 0 \ 0 \ \mathbf{m}_8 \ \mathbf{m}_9 \ \mathbf{m}_{16}] \quad (12.117)$$

$$\mathbf{C}_3 = [0 \ 0 \ 0 \ 0 \ 0 \ 0 \ 0 \ 0 \ 0 \ \mathbf{m}_{10}] \quad (12.118)$$

where \mathbf{m}_i are columns of \mathbf{M} .

Since \mathbf{m} contains all monomials in x, y, z up to degree three, we could have written similar equations as Equation 12.113 with x and y .

Equation 12.113 is known as a Polynomial Eigenvalue Problem (PEP) [22] of degree three. The standard solution to such a problem is to relax it into a generalized eigenvalue problem of a larger size as follows.

⁴Matrix \mathbf{M} can be obtained by the following Maple [18] program

```
>with(LinearAlgebra):
>G0:=<<g011|g012|g013>,<g021|g022|g023>,<g031|g032|g033>>:
>G1:=<<g111|g112|g113>,<g121|g122|g123>,<g131|g132|g133>>:
>G2:=<<g211|g212|g213>,<g221|g222|g223>,<g231|g232|g233>>:
>G3:=<<g311|g312|g313>,<g321|g322|g323>,<g331|g332|g333>>:
>trc:=E->simplify((2*E.Transpose(E)-Trace(Transpose(E).E)*IdentityMatrix(3,3)).E):
>eq:=op(convert(trc(G),listlist)),Determinant(G]):
>mo:=tdeg(x,y,z);
>m:=PolyVarMonomials(eq,mo);
m := [x^3, yx^2, y^2x, y^3, zx^2, zyx, zy^2, z^2x, z^2y, z^3, x^2, yx, y^2, zx, zy, z^2, x, y, z, 1]
>M:=PolyCoeffMatrix(eq,m,mo):
>M[1,1];
2g122g112g121 + 2g133g113g131 - g123^2g111 - g122^2g111 + 2g132g112g131 - g132^2g111 + g131^2g111 + g112^2g111 + g111^3 +
2g123g113g121 - g133^2g111 + g121^2g111 + g113^2g111
```

We can write $z^2\mathbf{c} = z(z\mathbf{c})$ and $z\mathbf{c} = z(\mathbf{c})$ altogether with Equation 12.113 in a matrix form as

$$\begin{bmatrix} 0 & \mathbf{I} & 0 \\ 0 & 0 & \mathbf{I} \\ -\mathbf{C}_0 & -\mathbf{C}_1 & -\mathbf{C}_2 \end{bmatrix} \begin{bmatrix} \mathbf{c} \\ z\mathbf{c} \\ z^2\mathbf{c} \end{bmatrix} = z \begin{bmatrix} \mathbf{I} & 0 & 0 \\ 0 & \mathbf{I} & 0 \\ 0 & 0 & \mathbf{C}_3 \end{bmatrix} \begin{bmatrix} \mathbf{c} \\ z\mathbf{c} \\ z^2\mathbf{c} \end{bmatrix} \quad (12.119)$$

$$\mathbf{A} \mathbf{v} = z \mathbf{B} \mathbf{v} \quad (12.120)$$

This is a Generalized Eigenvalue Problem (GEP) [22] of size 30×30 , which can be solved for z and \mathbf{v} . Values of x, y can be recovered from \mathbf{v} as $x = \mathbf{c}_8/\mathbf{c}_{10}$ and $y = \mathbf{c}_9/\mathbf{c}_{10}$. It provides 30 solutions in general.

When \mathbf{C}_0 is regular, we can pass to a standard eigenvalue problem for a non-zero z by inverting \mathbf{A} and using $w = 1/z$

$$\begin{bmatrix} -\mathbf{C}_0^{-1}\mathbf{C}_1 & -\mathbf{C}_0^{-1}\mathbf{C}_2 & -\mathbf{C}_0^{-1}\mathbf{C}_3 \\ \mathbf{I} & 0 & 0 \\ 0 & \mathbf{I} & 0 \end{bmatrix} \begin{bmatrix} w^2\mathbf{c} \\ w\mathbf{c} \\ \mathbf{c} \end{bmatrix} = w \begin{bmatrix} w^2\mathbf{c} \\ w\mathbf{c} \\ \mathbf{c} \end{bmatrix} \quad (12.121)$$

Bibliography

- [1] Paul R. Halmos. *Naive Set Theory*. Springer-Verlag, 1974.
- [2] David Cox, John Little, and Donald O’Shea. *Ideals, Varieties, and Algorithms: An Introduction to Computational Algebraic Geometry and Commutative Algebra*. Springer, 3rd edition, 2015.
- [3] Walter Rudin. *Principles of Mathematical Analysis*. McGraw-Hill, 1976.
- [4] Paul R. Halmos. *Finite-Dimensional Vector Spaces*. Springer-Verlag, 2000.
- [5] Carl Meyer. *Matrix Analysis and Applied Linear Algebra*. SIAM: Society for Industrial and Applied Mathematics, Philadelphia, PA, USA, 2001.
- [6] Petr Olšák. Úvod do algebry, zejména lineární. FEL ČVUT, Praha, 2007.
- [7] Pavel Pták. Introduction to linear algebra. Vydavatelství ČVUT, Praha, 2007.
- [8] Gilbert Strang. *Introduction to Linear Algebra*. Wellesley Cambridge, 3rd edition, 2003.
- [9] Seymour Lipschutz. *3,000 Solved Problems in Linear Algebra*. McGraw-Hill, 1st edition, 1989.
- [10] Jim Hefferon. *Linear Algebra*. Virginia Commonwealth University Mathematics, 2009.
- [11] Michael Artin. *Algebra*. Prentice Hall, Upper Saddle River, NJ 07458, USA, 1991.
- [12] Yoshiaki Ueno and Kazuhisa Maehara. An elementary proof of the generalized Laplace expansion formula. *Tokyo Polytechnic University Bulletin*, 25(1):61–63, 2003. http://www.t-kougei.ac.jp/research/bulletin_e/.
- [13] Cyrus Colton MacDuffee. *The Theory of Matrices*. Dover Publications Inc., 2004. <http://books.google.cz/books?id=8hQG7ByP53oC>.
- [14] Saunders MacLane and Garret Birkhoff. *Algebra*. Chelsea Pub. Co., 3rd edition, 1988.
- [15] Richard Hartley and Andrew Zisserman. *Multiple View Geometry in Computer Vision*. Cambridge, 2nd edition, 2003.
- [16] J. A. Grunert. Das pothenotische problem in erweiterter gestalt nebst über seine anwendungen in der geodäsie. *Grunerts Archiv für Mathematik und Physik*, 1:238–248, 1841.
- [17] David Cox, John Little, and Donald O’Shea. *Using Algebraic Geometry*. Springer, 1998.
- [18] Ltd. Cybernet Systems Co. Maple. <http://www.maplesoft.com/products/maple/>.
- [19] Zuzana Kukulova, Martin Bujnak, and Tomas Pajdla. Polynomial eigenvalue solutions to minimal problems in computer vision. *IEEE Transactions on Pattern Analysis and Machine Intelligence*, 2012.
- [20] D. Nistér. An efficient solution to the five-point relative pose problem. *IEEE Transactions on Pattern Analysis and Machine Intelligence*, 26(6):756–770, June 2004.
- [21] H. Stewenius, C. Engels, and D. Nistér. Recent developments on direct relative orientation. *ISPRS J. of Photogrammetry and Remote Sensing*, 60:284–294, 2006.
- [22] Z. Bai, J. Demmel, J. Dongarra, A. Ruhe, and H. van der Vorst. *Templates for the Solution of Algebraic Eigenvalue Problems*. SIAM, Philadelphia, 2000.

Index

- [n], 5
- determinant, 5
- sign, 5
- determinant, 6
- inversion, 5
- monotonic, 6
- permutation, 5

- affine coordinate system, 23
- affine function, 15
- affine space, 21
- axioms of linear space, 18
- axioms of affine space, 22

- basis, 18
- bound vector, 17

- camera pose, 42
- camera calibration matrix, 42
- camera cartesian coordinate system, 42
- camera calibration, 42
- camera coordinate system, 34
- camera projection matrix, 46
- coordinate linear space, 2
- coordinates, 19
- cross product, 6

- dual basis, 9
- dual space, 9

- epipolar plane, 113
- epipolar geometry, 113
- epipolar line, 113
- epipole, 113
- essential matrix, 114

- focal length, 42
- free vector, 20
- Frobenius norm, 119
- fundamental matrix, 114

- geometric scalars, 16
- geometric vector, 17

- homogeneous coordinates, 93
- homogeneous coordinates of a line, 93
- homogeneous coordinates of a point, 93
- homography, 60
- horizon, 99

- ideal line, 92
- ideal plane, 102
- image calibration matrix, 46
- image plane, 34
- image projection matrix, 37

- join, 95

- Kronecker product, 12

- line at infinity, 92
- linear function, 15
- linear space, 18

- marked ruler, 15
- meet, 95

- omnidirectional image, 73
- origin of affine coordinate system, 23

- panoramic image, 73
- partition, 19
- perspective camera, 34
- point at infinity, 89
- position vector, 23
- principal plane, 34
- principal point, 45
- projection center, 34
- projective space, 88

- real projective plane
 - affine point, 88, 90

algebraic model, 89
geometrical model, 88
ideal point, 89, 90
line, 90
point, 88

spherical image, 73
standard basis, 2

three-dimensional real projective space, 101

vanishing point, 98
vanishing line, 99
vector product, 6
vector product, 7

world coordinate system, 34
world unit length, 50

zero bound vector, 17